

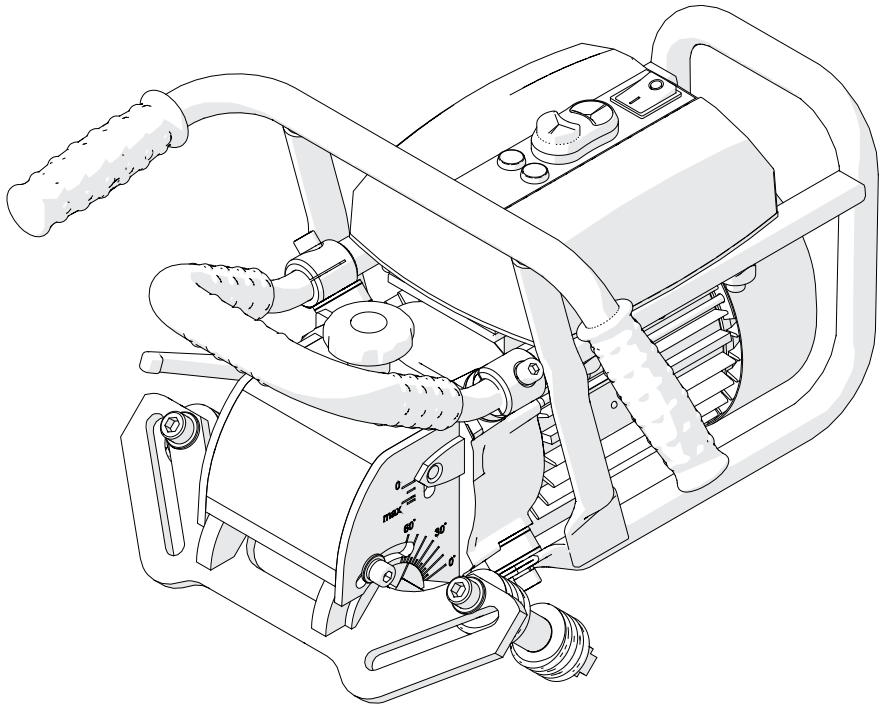

BM21 BEVELLING MACHINE

OPERATOR'S MANUAL



PART NO. WA-BM21

Ver: 1.1



TO PREVENT SERIOUS INJURY OR DAMAGE TO YOUR BEVELLING MACHINE,
READ AND UNDERSTAND ALL WARNINGS AND INSTRUCTIONS BEFORE USE



TABLE OF CONTENTS

1.	GENERAL INFORMATION	3
1.1.	Application	3
1.2.	Technical data	3
1.3.	Dimensions	4
1.4.	Design	5
1.5.	Equipment included	6
2.	SAFETY PRECAUTIONS	7
3.	STARTUP AND OPERATION	9
3.1.	Adjusting the bevel angle and width	9
3.2.	Adapting for pipes with diameters of 150–300 mm	10
3.3.	Adapting for pipes with diameters of more than 300 mm (option)	13
3.4.	Operating	14
3.5.	Replacing the cutting inserts	15
3.6.	Replacing the milling head	17
4.	SPARE AND WEARING PARTS	18
5.	ACCESSORIES	18
6.	WIRING DIAGRAM	19
7.	PARTS LIST	20

LIMITED WARRANTY

Industrial Tool & Machinery Sales (hereinafter referred to as ITMS) will, within twelve (12) months from the original date of purchase, repair or replace any goods found to be defective in materials or workmanship.

This warranty is void if the item has been damaged by accident, neglect, improper service or other causes not arising out of defects in materials or workmanship. This warranty does not apply to machines and/or components which have been altered, changed, or modified in any way, or subjected to overloading or use beyond recommended capacities and specifications. Worn componentry due to normal wear and tear is not a warranty claim. Goods returned defective shall be returned prepaid freight to ITMS or agreed repair agent, which shall be the buyer's sole and exclusive remedy for defective goods. ITMS accepts no additional liability pursuant to this guarantee for the costs of travelling or transportation of the product or parts to and from ITMS or the service agent or dealer, such costs are not included in this warranty.

Our goods come with guarantees which cannot be excluded under the Australian Consumer Law. You are entitled to replacement or refund for a major failure and to compensation for other reasonably foreseeable loss or damage. You are also entitled to have the goods repaired or replaced if the goods fail to be of acceptable quality and the failure does not amount to a major failure.

THE MANUFACTURER RESERVES THE RIGHT TO MAKE IMPROVEMENTS AND MODIFICATIONS TO DESIGN WITHOUT PRIOR NOTICE.

PRODUCTS IMPORTED AND DISTRIBUTED NATIONALLY BY:



INDUSTRIAL TOOL & MACHINERY SALES
11 EASTERN SERVICE ROAD, STAPYLTON, QLD, 4207
T: 07 3287 1114 E: sales@industrialtool.com.au
F: 07 3287 1115 W: www.itmtools.com.au

1. GENERAL INFORMATION

1.1. Application

The BM-21 is a beveling machine designed to bevel carbon steel. The machine can bevel plates, as well as pipes with outer diameters of 150–300 mm (6–12"), at an angle of 0–60° and with the bevel width of up to 21 mm (13/16"). Also, the machine contains dampers to reduce vibrations.

When equipped with an optional guide, the machine can bevel pipes with outer diameters of more than 300 mm (12").

1.2. Technical data

Voltage	1~ 220–240 V, 50–60 Hz
Power	1600 W (for 50 Hz) 1800 W (for 60 Hz)
Rotational speed	2780–3340 rpm (at 230 V)
Protection level	IP 20
Protection class	I
Milling speed	550 m/min (1800 ft/min, for 50 Hz) 650 m/min (2200 ft/min, for 60 Hz)
Maximum bevel width (<i>b</i>)	21 mm (13/16", Fig. 1)
Bevel angle (β)	0–60° (Fig. 1)
Vibration level	3.77 m/s ² (12.4 ft/s ²)
Weight	23 kg (51 lbs)
Noise level	L _p (A)>70dB(A)

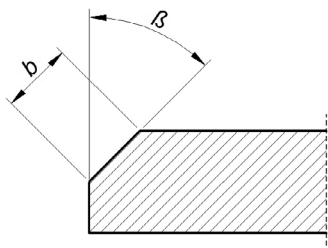

β	0°	30°	45°	60°
<i>b</i>	21 mm	18.5 mm	21 mm	18.5 mm

Fig. 1. Bevel dimensions; maximum bevel width depending on the angle

1.3. Dimensions

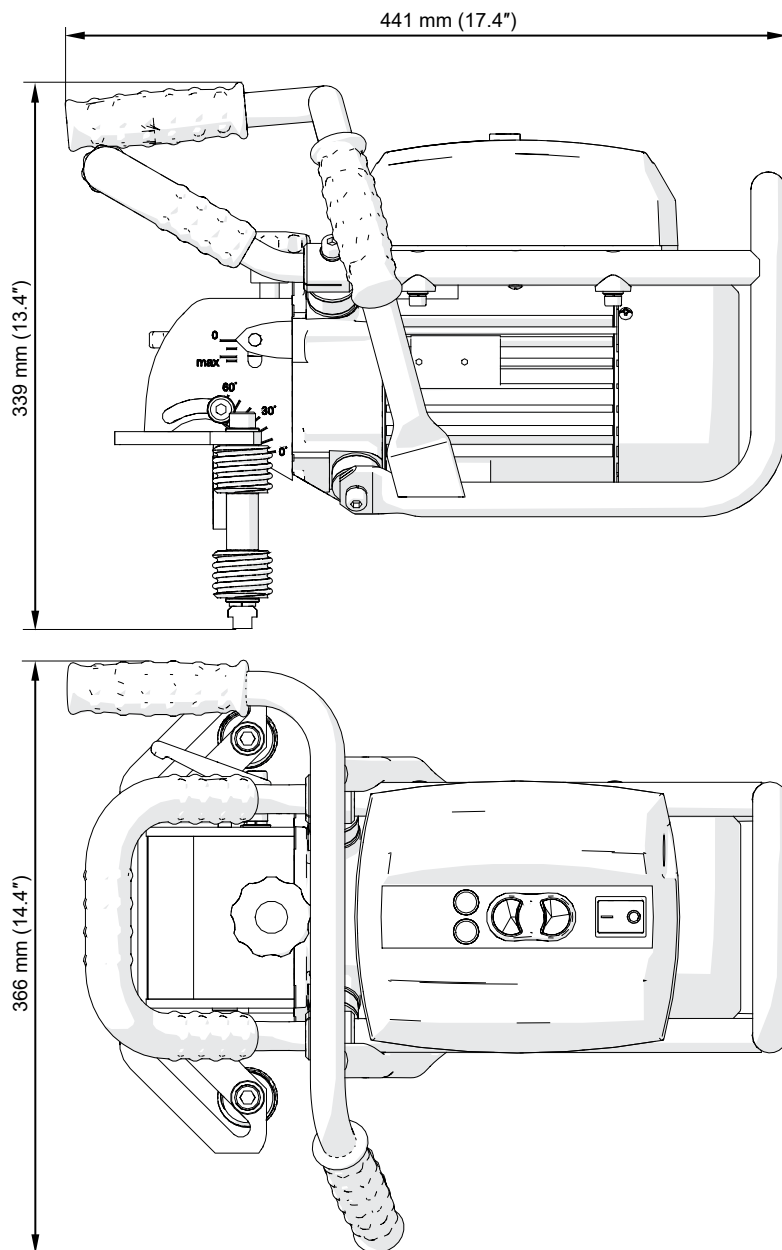

1.4. Design

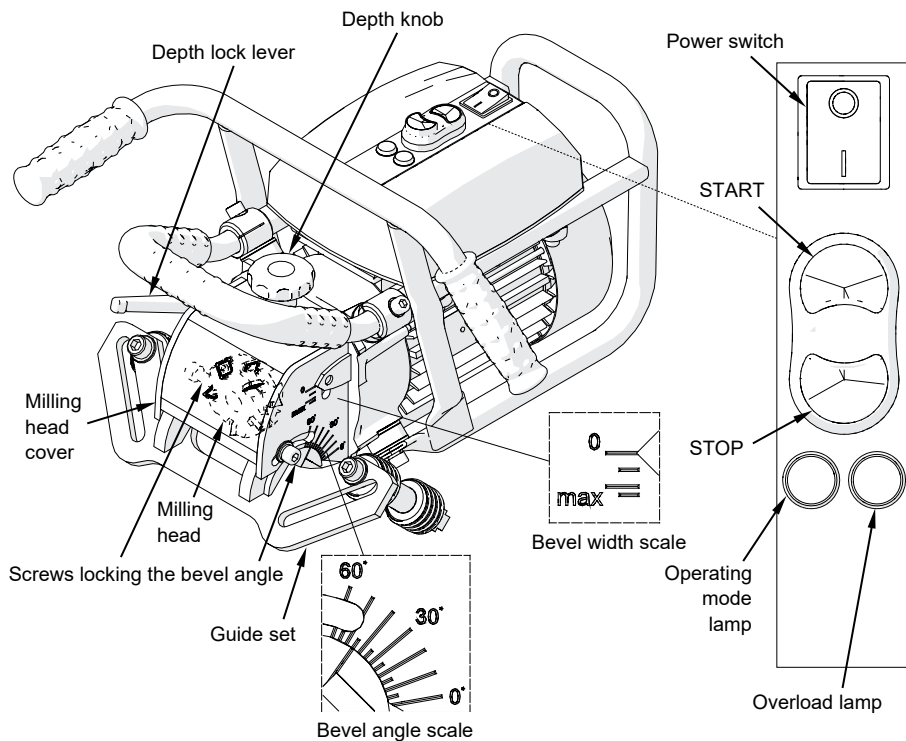
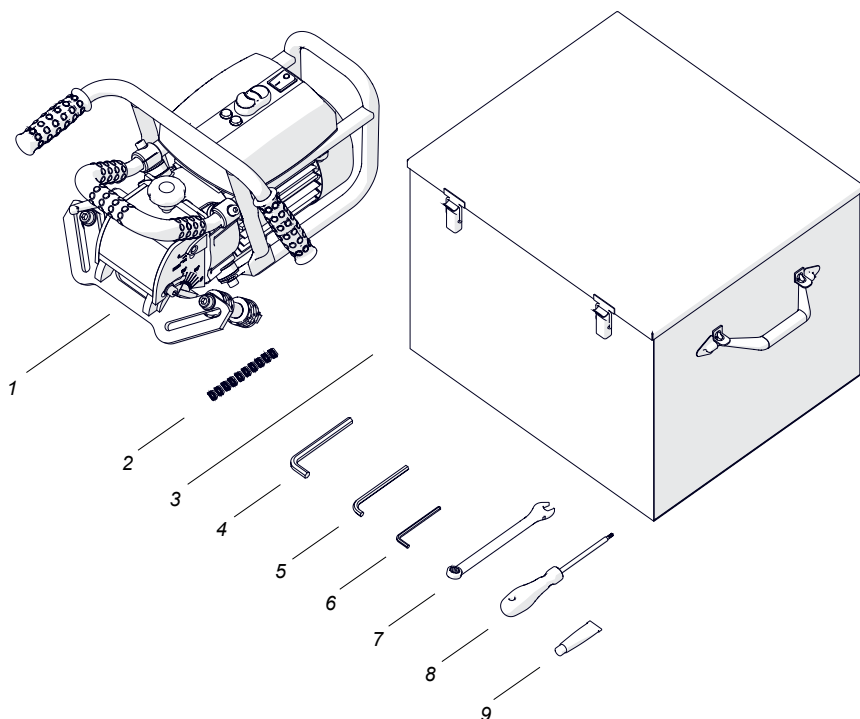

Fig. 2. View of the machine and the control panel

1.5. Equipment included



1	Bevelling machine	1 unit
2	Cutting insert	10 units
3	Metal box	1 unit
4	8 mm hex wrench	1 unit
5	6 mm hex wrench	1 unit
6	4 mm hex wrench	1 unit
7	12 mm flat wrench	1 unit
8	T15P torx screwdriver	1 unit
9	Grease for screws	1 unit
-	Operator's Manual	1 unit

2. SAFETY PRECAUTIONS

1. Before use, read this Operator's Manual and complete a training in occupational safety and health.
2. Use only in applications specified in this Operator's Manual.
3. Make sure that the machine has all parts and they are genuine and not damaged.
4. Make sure that the specifications of the power source are the same as those specified on the rating plate.
5. Connect the machine to a correctly grounded power source.
6. Do not pull the cord. This can cause damage and electric shock.
7. Keep untrained bystanders away from the machine.
8. Before each use, ensure the correct condition of the machine, power source, power cord, plug, control parts, and milling tools.
9. Before each use, make sure that no part is cracked or loose. Make sure to maintain correct conditions that can have an effect on the operation of the machine.
10. Keep the machine dry. Do not expose the machine to rain, snow, or frost.
11. Keep the work area well-lit, clean, and free of obstacles.
12. Do not use near flammable materials or in explosive environments.
13. Use only tools specified in this Operator's Manual.
14. Do not use tools that are dull or damaged.
15. Make sure that the cutting inserts and the milling head are correctly attached. Remove wrenches from the work area before you connect the machine to the power source.
16. If the cutting edge of an insert is worn, rotate all inserts by 90°. If all edges are worn, install new inserts specified in this Operator's Manual.
17. Use eye protection, ear protection, non-skid footwear, gloves, and protective clothing. Do not use loose clothing.
18. Do not touch chips or moving parts. Do not let anything catch in moving parts.
19. After each use, clean the machine and the milling head with a cotton cloth and no chemical agents. Do not remove chips with bare hands.
20. If you are not going to use the machine for an extended period, put anti-corrosion material on the steel parts.

21. Maintain the machine and install/remove parts and tools only after you unplug the machine from the power source.
22. Repair only in a service center appointed by the seller.
23. If the machine falls, is wet, or has any damage, stop the work and promptly send the machine to the service center for check and repair.

3. STARTUP AND OPERATION

3.1. Adjusting the bevel angle and width

Unplug the machine from the power source. Start with setting the bevel width to zero. To do this, loosen the lock lever (Fig. 3), rotate the knob to set '0' on the bevel width scale, and tighten the lever.

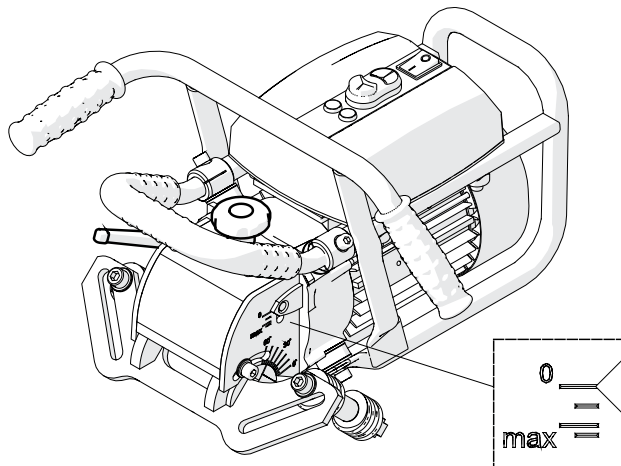

Fig. 3. Initial setting the bevel width to zero

To set the required bevel angle (Fig. 4), use the 6 mm hex wrench to loosen two side screws. Rotate the guide set to get the required angle on the scale, and tighten the screws in this new position.

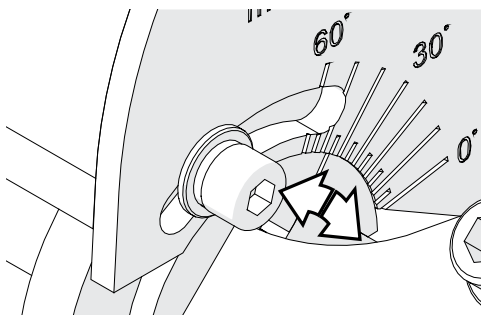

Fig. 4. Setting the bevel angle (45° is set on the drawing)

After you set the bevel angle, use the depth knob to adjust the bevel width. The width scale shows only a rough value because the bevel width varies with the angle. For example, for 10° the maximum width b (Fig. 1) is about 18 mm (11/16"), while the

width scale shows about 9 mm (6/16"). Increasing the depth at this angle will distort the bevel. The maximum bevel width ($b = 21$ mm, 13/16") is for 45°. Find the required bevel width for the required angle in practice. To do this, gradually increase the penetration of the milling head into the workpiece.

3.2. Adapting for pipes with diameters of 150–300 mm

To bevel pipes with diameters of 150–300 mm (6–12"), assemble the standard guide set in a different way. To do this, use the 6 mm hex wrench to remove two side screws (1, Fig. 5) and remove the guide set (2). Then, rotate the set by 180° around the vertical axis (3), install again (4), and attach with the screws (1).

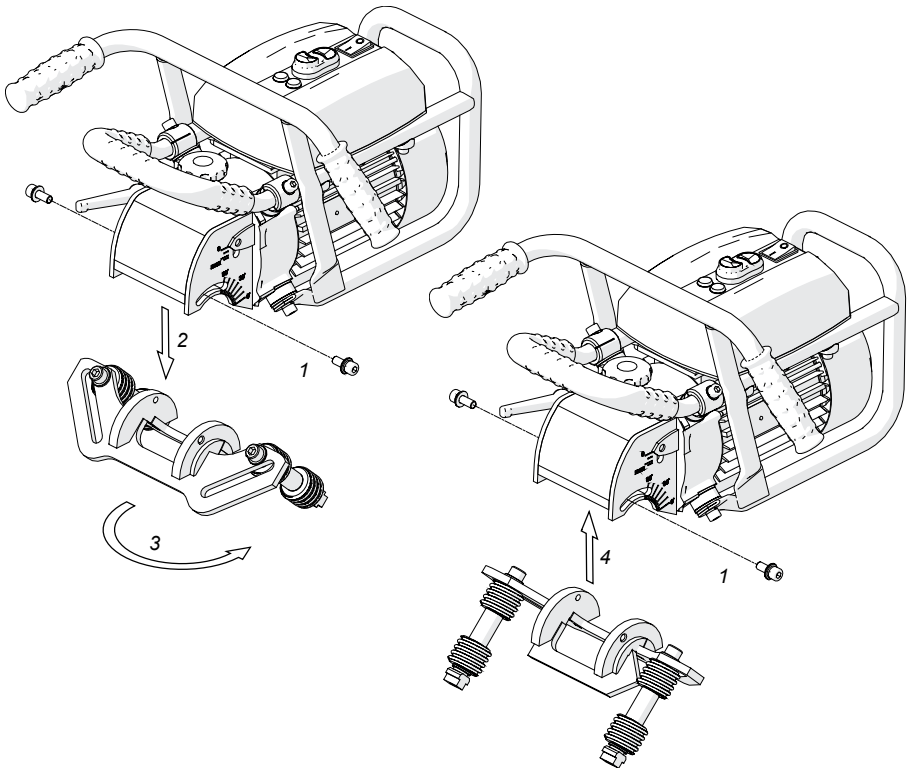

Fig. 5. Rotating and installing the guide set

Use the 12 mm flat wrench to prevent the turn of the T-nut and use the 8 mm hex wrench to remove the roller screw. Next, move the rollers from the hole (Fig. 6a) to the slot. Install the rollers as shown in Fig. 6b and put the T-nut into the slot.

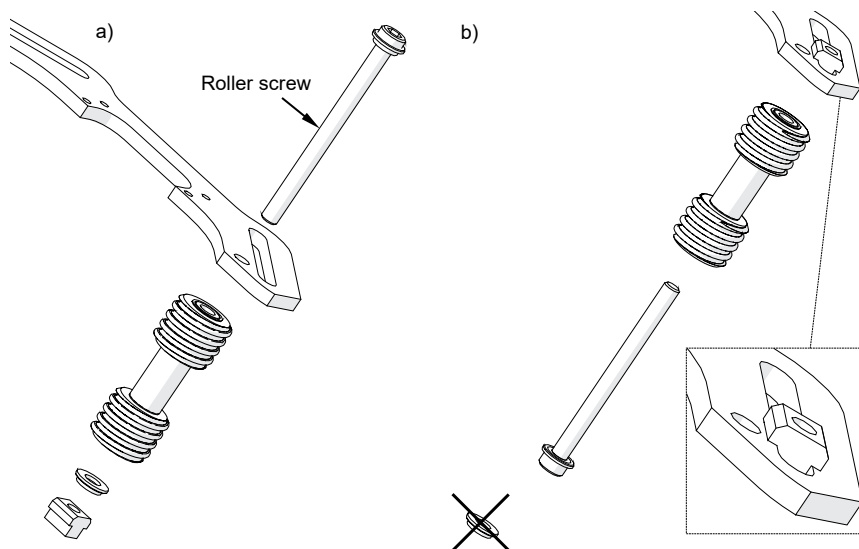

Fig. 6. Moving the rollers from the hole to the slot

Loosen the depth lock lever (Fig. 7) and rotate the depth knob to set '0' on the bevel width scale. Then, move the rollers away from each other as far as possible.

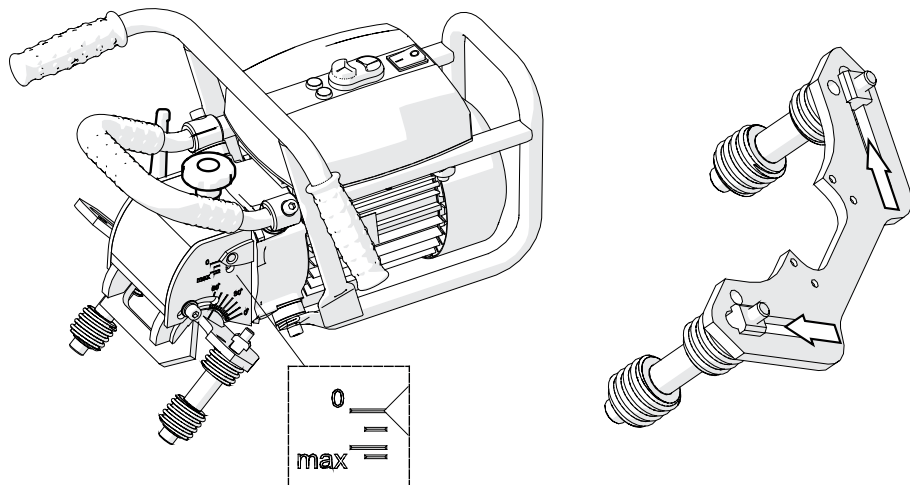

Fig. 7. Initial setting the bevel width to zero and separating the rollers

Put the machine on a vertical pipe so that the surfaces of the guide set are in contact with the face and side of the pipe. Then, move the rollers symmetrically to make them contact the pipe (Fig. 8) and tighten them in this position. Set the required bevel angle and width as described before.

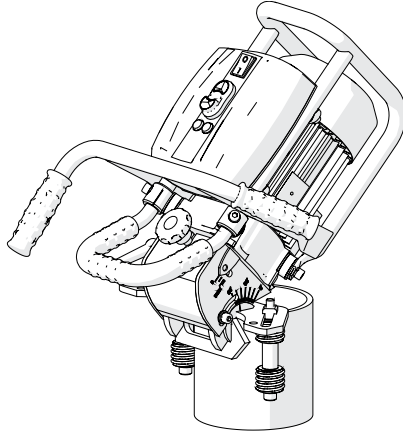

Fig. 8. Machine prepared for work on pipes with diameters of 150–300 mm (6–12")

3.3. Adapting for pipes with diameters of more than 300 mm (option)

To bevel pipes with diameters of more than 300 mm (10"), assemble the guide set by using an optional guide. To do this, remove the guide set (1, 2, Fig. 5) and use the 4 mm hex wrench to remove the standard guide. Then, assemble the guide for pipes with diameters of more than 300 mm (Fig. 9) and tighten with the screws. Install the rollers and adjust the required bevel angle and width as described before.

The guide allows machining of very large diameters. But it ensures the most stable operation in the range of 300–600 mm.

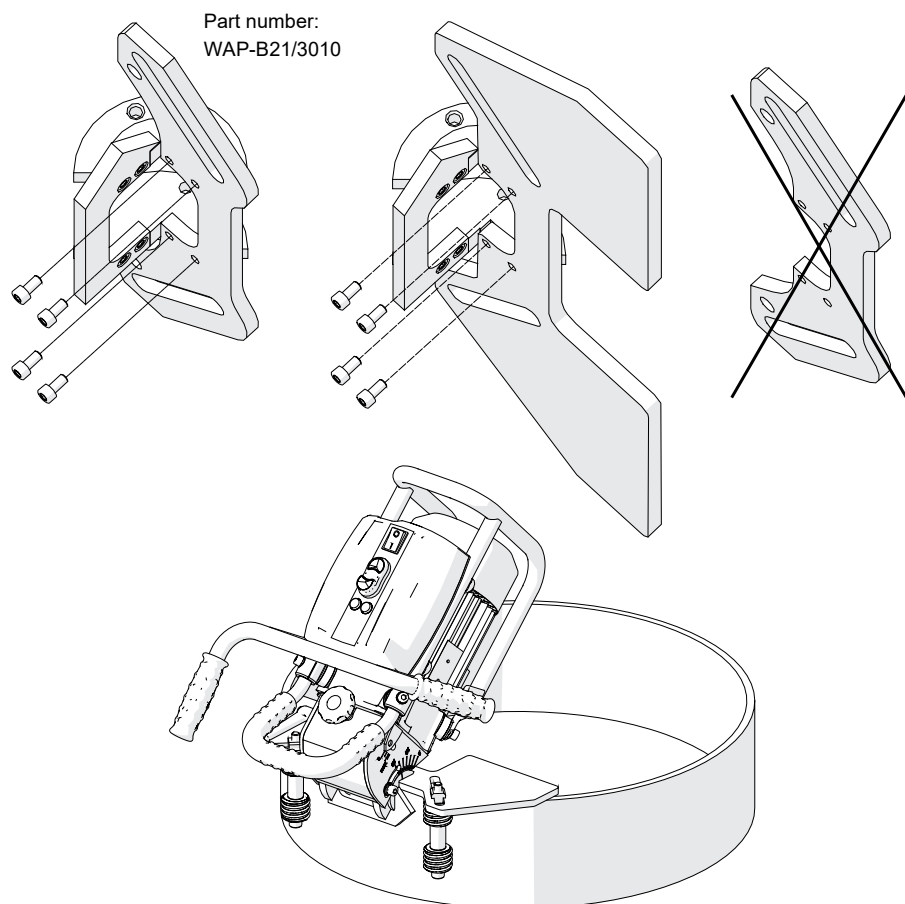

Fig. 9. Machine prepared for work on pipes with diameters of more than 300 mm

3.4. Operating

After you set the bevel angle and width, connect the machine to a correctly grounded power source. Put the machine on the right so that the rollers are on the plate. Keep a gap between the milling head and the plate (Fig. 10).

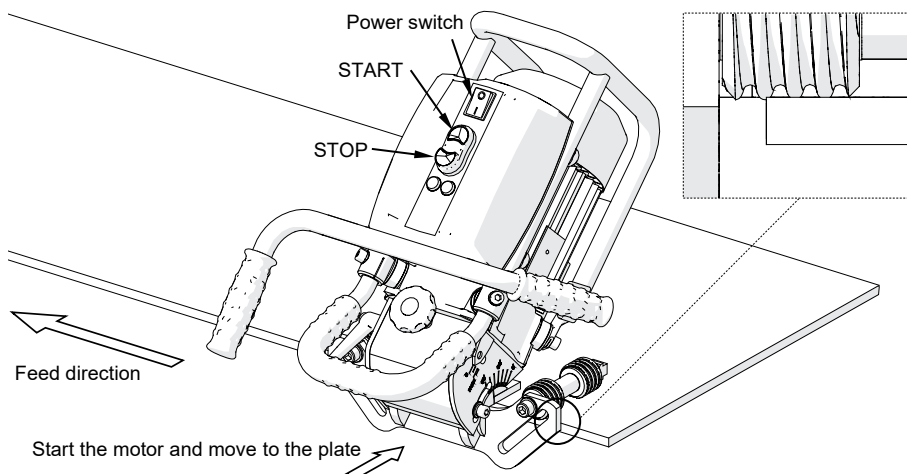

Fig. 10. Machine correctly put on the workpiece

Set the power switch to 'I' and press the green START button to start the motor. Move the machine to the plate and bevel by moving the machine to the left. Constantly press the machine to the plate.

Bevelling is done according to the counter-rotation. The rotation direction of the milling head is marked on the motor disk under the cover of the milling head.

The feed rate depends on the profile and composition of the workpiece.

To get the maximum bevel width (18.5 mm) for the angles 15–30° or 55–60°, minimum two passes are recommended. To get the maximum bevel width (21 mm) for the angles 30–55°, minimum three passes are recommended.

If an overload occurs because of, for example, too fast feed, the red overload lamp comes on. If you continue work in such a case, the motor stops. Then, move the machine away from the plate and set the power switch to 'O' to turn off the power. Next, wait until the overload lamp comes off, and turn on the power again.

You can work near the overload (when the red lamp flashes), but do not let the motor temperature increase more than 85°C (185°F). This can lead to damage of the motor windings. After each hour of work under full load, stop the motor for 10–

15 minutes. Do not try to decrease the motor temperature by working without load. The motor will then get hotter than when working with load.

After the work is finished, press the STOP button to stop the motor. Then, set the power switch to 'O'. Use petroleum ether to clean oil from the workpiece.

Clean the machine with a cotton cloth and no chemical agents.

3.5. Replacing the cutting inserts

Unplug the machine from the power source. Remove the lever (1, Fig. 11), the indicator (2), and the milling head cover (3).

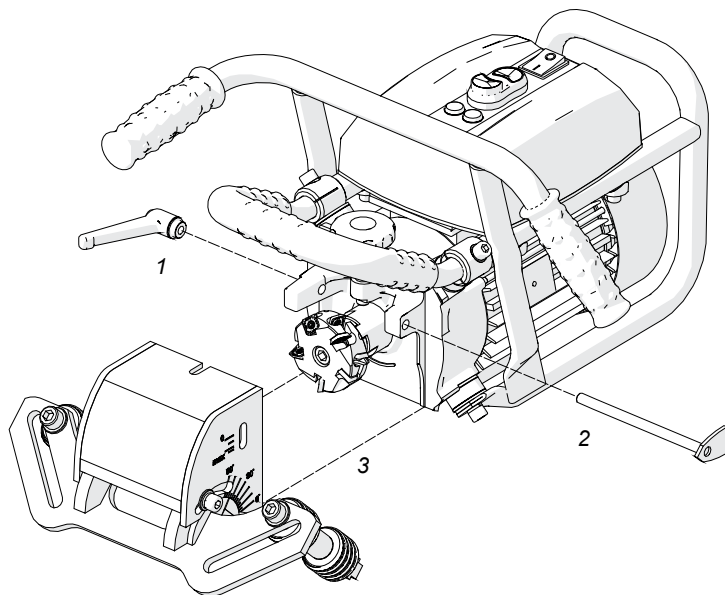

Fig. 11. Removing the milling head cover

Use the supplied T15P screwdriver to remove the fixing screw (Fig. 12), remove the insert, and clean the socket. Rotate the insert by 90° and install again or replace to a new one if all four edges are worn. To replace an insert from the internal ring, first remove the insert from the external ring.

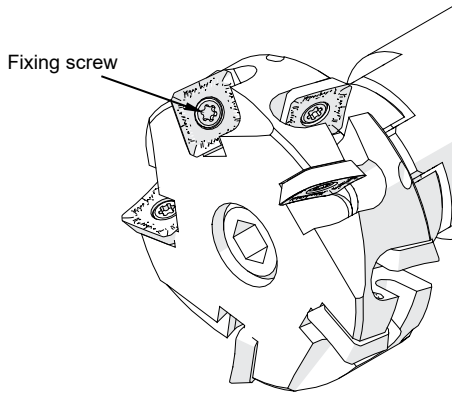

Fig. 12. Replacing the cutting inserts

When you make bevels of low width, the cutting inserts wear only on one, inner corner. Then, the good thing is to change the inserts between the rings of the milling head (Fig. 13). This will extend the life of the inserts.

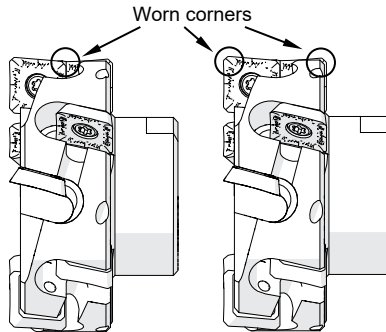

Fig. 13. Changing the cutting inserts between the rings

3.6. Replacing the milling head

Remove the milling head cover as shown in Fig. 11. Use the 32 mm flat wrench to prevent the turn of the spindle (Fig. 14). Then, use the 8 mm hex wrench to remove the screw, and remove the milling head. The 32 mm flat wrench is not included in standard equipment.

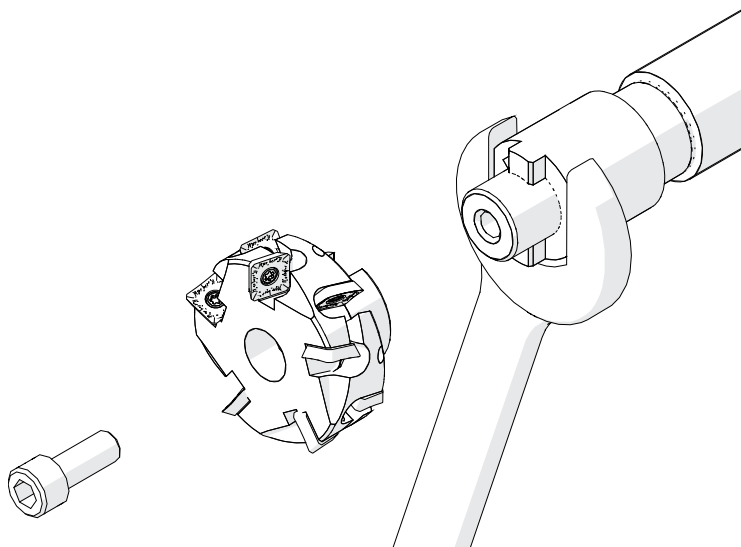

Fig. 14. Replacing the milling head

4. SPARE AND WEARING PARTS

Name	Number
Milling head (including fixing screws and screwdriver; 10 inserts required)	WAP-B21/3124
Cutting insert (sold 10 per box)	WAP-B020
Fixing screw for inserts	WAP-B030
T15P torx screwdriver for fixing screws	WAP-BM7/1040
Grease for screws (5 g, 0.17 oz)	WAP-BM16/1110

5. ACCESSORIES

5.1. Guide for pipes with diameters of more than 300 mm

Part number:
WAP-B21/3010

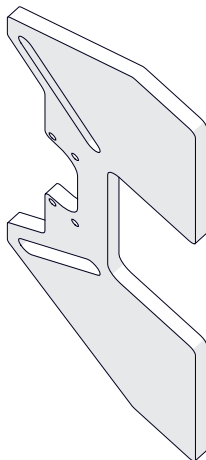

5.2. Cutting tools

Part number	Part name
WAP-B040	Cutting insert (10 required, sold 10 per box)

6. WIRING DIAGRAM

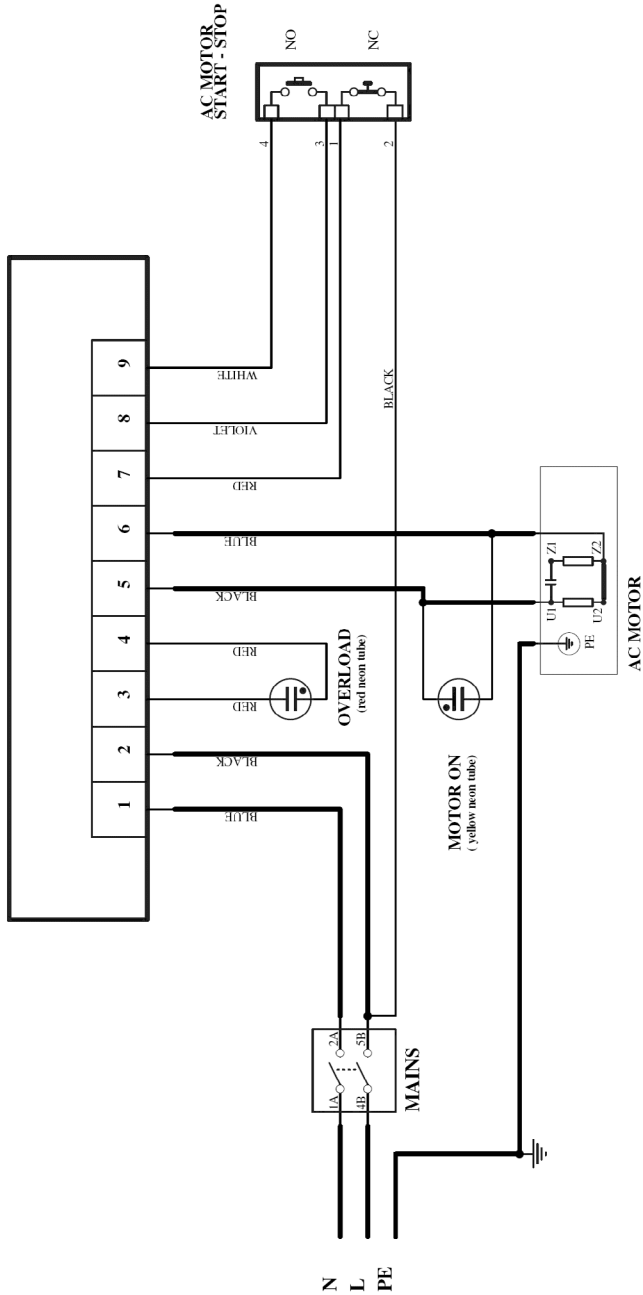

7. PARTS LIST

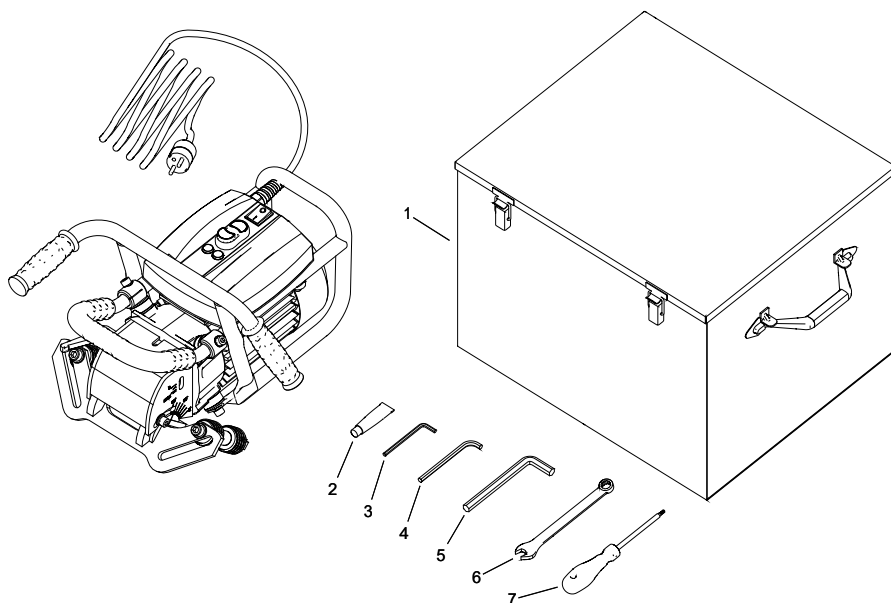

ITEM	PART NUMBER	DESCRIPTION	Q-TY
1	SKR-0461-15-00-00-0	METAL BOX	1
2	SMR-000005	GREASE FOR SCREWS	1
3	KLC-000007	4 MM HEX WRENCH	1
4	KLC-0461-16-00-00-0	6 MM MODIFIED HEX WRENCH	1
5	KLC-000011	8 MM HEX WRENCH	1
6	KLC-000032	12 MM COMBINATION WRENCH	1
7	WKT-000005	T15P TORX PLUS SCREWDRIVER	1

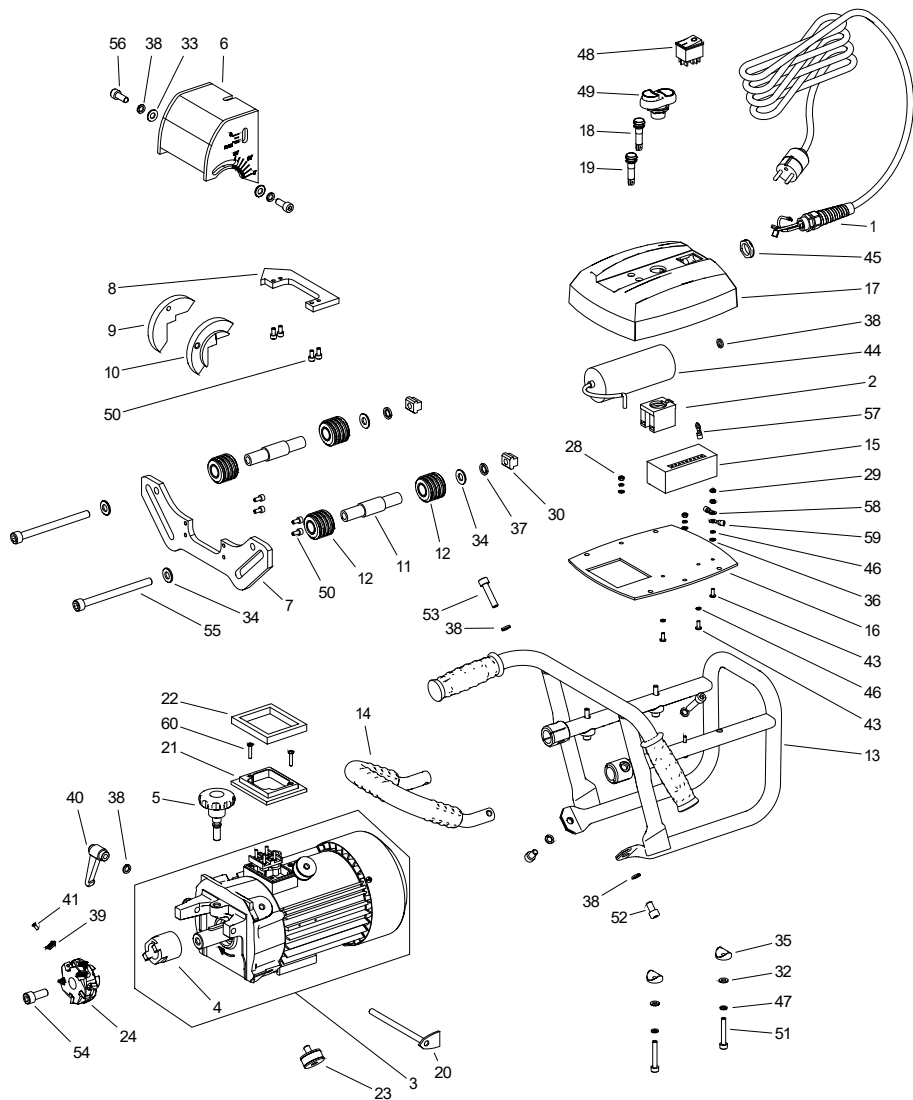

ITEM	PART NUMBER	DESCRIPTION	Q-TY
1	PWD-0461-17-00-00-2	POWER CORD - 230V (AU)	1
2	BLO-000023	START-STOP CONTACT BLOCK	1
3	SLN-0461-01-00-00-2	MOTOR ASSY - 230V	1
4	ZBI-0461-02-00-00-0	DRIVING RING	1

ITEM	PART NUMBER	DESCRIPTION	Q-TY
5	PKT-0461-04-00-00-0	KNOB	1
6	OSL-0461-05-00-00-0	MILLING HEAD COVER	1
7	PRW-0461-06-01-00-1	VERTICAL GUIDE	1
8	PRW-0461-06-02-00-1	HORIZONTAL GUIDE	1
9	OBS-0461-06-03-00-1	GUIDE HOLDER I	1
10	OBS-0461-06-04-00-1	GUIDE HOLDER II	1
11	OSK-0461-06-05-00-0	PIVOT	2
12	RLK-0461-06-06-00-0	ROLLER	4
13	RMK-0461-07-00-00-0	FRAME	1
14	RKJ-0461-08-00-00-0	FRONT HANDLE	1
15	ZSP-0461-25-00-00-0	ELECTRONIC MODULE ASSY - 230V	1
16	PLY-0461-09-03-00-0	BOTTOM PLATE	1
17	PKR-0461-09-04-00-0	CONTROLLER HOUSING COVER	1
18	KON-0461-09-10-00-0	RED LAMP	1
19	KON-0461-09-11-00-0	YELLOW LAMP	1
20	WSK-0461-11-00-00-0	PENETRATION INDICATOR ASSY	1
21	LCZ-0461-12-00-00-0	LINK	1
22	USZ-0461-13-00-00-0	RUBBER SEAL	1
23	WBR-0461-14-00-00-0	DAMPER	4
24	GLW-0461-03-01-00-0	MILLING HEAD WITH BOLTS	1
28	NKR-000014	HEX NUT M4	2
29	NKR-000032	NUT SHORT M4	2
30	NKR-000082	T-NUT	2
32	PDK-000021	ROUND WASHER 6.4	4
33	PDK-000022	ROUND WASHER 8.4	3
34	PDK-000026	ROUND WASHER 10.5	4
35	PDK-000175	SADDLE WASHER	4
36	PDK-000060	EXTERNAL TOOTH SPRING WASHER 4.3	6
37	PDK-000052	SPRING WASHER 10.2	2
38	PDK-000051	SPRING WASHER 8.2	8
39	PLY-000282	CUTTING INSERT	10
39*	PLY-000591	CUTTING INSERT	10
40	RKJ-000010	HANDLEVER	1
41	SRB-000311	MOUNTING SCREW	10
43	WKR-000183	CROSS RECESSED PAN HEAD SCREW M4x10	4
44	KND-000114	CAPACITOR 30uF - 240V	1
45	NKR-000040	STRAIN RELIEF NUT	1
46	PDK-000043	SPRING WASHER 4.1	6
47	PDK-000046	SPRING WASHER 6.1	4
48	PNK-000013	POWER SWITCH	1
49	PRC-000007	MOTOR ON/OFF SWITCH	1
50	SRB-000075	HEX SOCKET HEAD CAP SCREW M5x10	8
51	SRB-000124	HEX SOCKET HEAD CAP SCREW M6x40	4

ITEM	PART NUMBER	DESCRIPTION	Q-TY
52	SRB-000141	HEX SOCKET HEAD CAP SCREW M8x14	2
53	SRB-000156	HEX SOCKET HEAD CAP SCREW M8x35	2
54	SRB-000046	HEX SOCKET HEAD CAP SCREW M10x25	1
55	SRB-000309	HEX SOCKET HEAD CAP SCREW M10x120	2
56	SRB-000148	HEX SOCKET HEAD CAP SCREW M8x20	2
57	WZK-0461-10-03-00-0	PILOT LIGHT WIRE SET	1
58	WZK-0461-09-08-00-0	CONTROLLER PLATE GROUNDING WIRE	1
59	WZK-0461-09-09-00-0	MOTOR GROUNDING WIRE	1
60	WKR-000446	CROSS RECESSED PAN HEAD SCREW M4x20	2

*optional

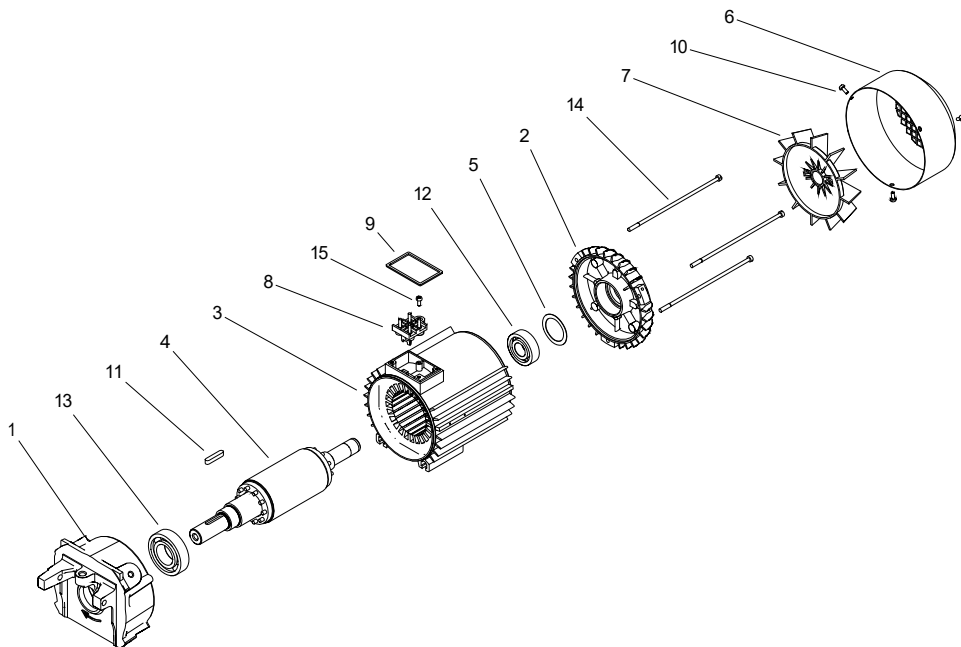

SLN-0461-01-00-00-2		MOTOR ASSY 230V	
ITEM	DESCRIPTION	PART NUMBER	Q-TY
1	TRC-0461-01-02-00-2	BEARING DISK N	1
2	TRC-000003	BEARING DISK P	1
3	KDL-000001	STARTER BODY 230V	1
4	WRN-000050	ROTOR	1
5	PDK-000040	CLEARANCE REMOVAL SPRING WASHER	1
6	OSL-000184	FAN COVER	1
7	WNT-000008	FAN	1
8	TBL-000032	4-TERMINAL PLATE	1
9	USZ-000030	SEAL no.4	1
10	WKR-000466	SELF-TAPPING SCREW M4x8	3
11	WPS-000015	PIN A6x6x32	1
12	LOZ-000139	BALL BEARING 20x47x14	1
13	LOZ-000140	BALL BEARING 30x62x16	1
14	SRB-000349	DRAWBOLT E/M5x168	3
15	WKR-000467	SELF-TAPPING SCREW M4x12	1