



CONSTRUCTION SERIES

PETROL GENERATOR

OPERATOR'S MANUAL



GC SERIES

MODELS: GC4000, GC6800, GC8100, GC10000

! TO PREVENT SERIOUS INJURY OR DAMAGE TO YOUR GENERATOR, READ AND UNDERSTAND ALL WARNINGS AND INSTRUCTIONS BEFORE USE !

Ver: 1.6

www.itmtools.com.au

TABLE OF CONTENTS

Warranty	2
Product Specifications	3
Safety Instructions	4
Unpacking	6
Assembly	7
Operation	9
Maintenance	22
Trouble Shooting	28
Parts Lists & Breakdowns	29
Wiring Diagrams	37

LIMITED WARRANTY

Industrial Tool & Machinery Sales (hereinafter referred to as ITMS) will, within twelve (12) months from the original date of purchase, repair or replace any goods found to be defective in materials or workmanship.

This warranty is void if the item has been damaged by accident, neglect, improper service or other causes not arising out of defects in materials or workmanship. This warranty does not apply to machines and/or components which have been altered, changed, or modified in any way, or subjected to overloading or use beyond recommended capacities and specifications. Worn componentry due to normal wear and tear is not a warranty claim. Goods returned defective shall be returned prepaid freight to ITMS or agreed repair agent, which shall be the buyer's sole and exclusive remedy for defective goods. ITMS accepts no additional liability pursuant to this guarantee for the costs of travelling or transportation of the product or parts to and from ITMS or the service agent or dealer, such costs are not included in this warranty.

Our goods come with guarantees which cannot be excluded under the Australian Consumer Law. You are entitled to replacement or refund for a major failure and to compensation for other reasonably foreseeable loss or damage. You are also entitled to have the goods repaired or replaced if the goods fail to be of acceptable quality and the failure does not amount to a major failure.

**THE MANUFACTURER RESERVES THE RIGHT TO MAKE IMPROVEMENTS AND
MODIFICATIONS TO DESIGN WITHOUT PRIOR NOTICE.**

PRODUCTS IMPORTED AND DISTRIBUTED NATIONALLY BY:



INDUSTRIAL TOOL & MACHINERY SALES
18 BUSINESS ST, YATALA QLD 4207
T: 07 3287 1114 E: sales@industrialtool.com.au
F: 07 3287 1115 W: www.itmtools.com.au

PRODUCT SPECIFICATIONS

Thank you for purchasing your GC Series Generator. This generator is fitted with IP66 outlets and RCD meaning it is worksite compliant. With built-in Pure Sine Wave technology (THD<5%), it's also ideal for powering tools, domestic appliances and sensitive electronics.

Please read and understand the content of this manual for safety guidelines, start-up, shutdown, operation, adjustment and maintenance instructions before using this product. Take all possible precautions to protect your own safety and that of the people in the immediate vicinity. Save this manual for future reference.

MODEL	GC4000	GC6800	GC8100	GC10000
Part Number	TM520-3400	TM520-5500	TM520-6500	TM520-8000
Voltage	240V ~ 50Hz	240V ~ 50Hz	240V ~ 50Hz	240V ~ 50Hz
KvA	4	6.8	8.1	10
Max. Power	3400W	5500W	6500W	8000W
Rated Power	3200W	5000W	6000W	7500W
Amps	14	20.8	25	30
Horse Power	8HP	13HP	15HP	17HP
Engine Type	4 Stroke	4 Stroke	4 Stroke	4 Stroke
Fuel Tank (L)	15	25	25	25
Fuel Type	Ron 91	Ron 91	Ron 91	Ron 91
Engine Power cc	224	420	420	457
Noise @ 7Mtr (full load)	76dB(A)	78dB(A)	79dB(A)	80dB(A)
Running Time 50% Load	14 Hours	13 Hours	12 Hours	10 Hours
DC Power	12V 8.3A	12V 8.3A	12V 8.3A	12V 8.3A
AC outlets	1 x 15A (IP66)	2 x 15A (IP66)	2 x 15A (IP66)	2 x 15A (IP66)
Start System	Electric (Push Button)	Electric (Push Button)	Electric (Push Button)	Electric (Push Button)
Remote Control	Yes	Yes	Yes	Yes
Pure Sine Wave	THD<5%	THD<5%	THD<5%	THD<5%
Alternator	AVR	AVR	AVR	AVR
Residual Current Device "RCD"	Yes	Yes	Yes	Yes
Oil Capacity	0.6L	1.1L	1.1L	1.1L
Recommended Oil	10W 30	10W 30	10W 30	10W 30
Low Oil Sensor	Yes	Yes	Yes	Yes
Wheel & Handle Kit	Yes	Yes	Yes	Yes
Weight	54Kg	83Kg	88Kg	95Kg

* (Automatic voltage regulator)

GENERAL SAFETY RULES FOR OPERATION**DANGER**

Never use the generator in a location that is wet or damp. Never expose the generator to rain, snow, water spray or standing water while in use. Protect the generator from all hazardous weather conditions. Moisture or ice can cause a short circuit or other malfunction in the electrical circuit.

Never operate the generator in an enclosed area. Engine exhaust contains carbon monoxide. Only operate the generator outside and away from windows, doors and vents.

WARNING

Voltage produced by the generator could result in death or serious injury.

- Never operate the generator in rain or a flood plain unless proper precautions are taken to avoid being subject to rain or a flood.
- Never use worn or damaged extension cords.
- Always have a licensed electrician connect the generator to the utility circuit.
- Never touch an operating generator if the generator is wet or if you have wet hands.
- Never operate the generator in highly conductive areas such as around metal decking or steel works.
- Always use grounded extension cords. Always use three-wire or double-insulated power tools.
- Never touch live terminals or bare wires while the generator is operating.
- Be sure the generator is properly grounded before operating.

WARNING

Petrol and petrol vapors are extremely flammable and explosive under certain conditions.

- Always refuel the generator outdoors, in a well-ventilated area.
- Never remove the fuel cap with the engine running.
- Never refuel the generator while the engine is running. Always turn engine off and allow the generator to cool before refueling.
- Only fill fuel tank with petrol.
- Keep sparks, open flames or other form of ignition (such as match, cigarette, static electric source away when refueling.
- Never overfill the fuel tank. Leave room for fuel to expand. Overfilling the fuel tank can result in a sudden overflow of petrol and result in spilled petrol coming in contact with HOT surfaces. Spilled fuel can ignite. If fuel is spilled on the generator, wipe up any spills immediately. Dispose of rag properly. Allow area of spilled fuel to dry before operating the generator.
- Wear eye protection while refueling.
- Never use petrol as a cleaning agent.
- Store any petrol containers in a well-ventilated area, away from any source of ignition.
- Check for fuel leaks after refueling. Never operate the engine if a fuel leak is discovered.

WARNING

Never operate the generator if powered items overheat, electrical output drops, there is sparking, flames or smoke coming from the generator, or if the receptacles are damaged.



Never use the generator to power medical support equipment.



Always remove any tools or other service equipment used during maintenance from the generator before operating.

NOTICE

Never modify the generator.

Never operate the generator if it vibrates at high levels, if engine speed changes greatly or if the engine misfires often.

Always disconnect tools or appliances from the generator before starting.

ADDITIONAL SAFETY RULES FOR GENERATORS

Do not force the generator. Use the correct generator for your application. The correct generator will do the job better and safer at the rate for which it was designed.

Do not use the generator if the engine switch does not turn it on and off. Any generator that cannot be controlled with the switch is dangerous and must be repaired.

Know exactly how to use the generator correctly. Be thoroughly familiar with proper use of the equipment and all engine controls, output receptacles, and connections. Know how to stop the engine quickly (see "Stopping the Generator").

Instruct operators. The engine owner must instruct all operators in safe engine set-up and operation. Only trained adults should set up and operate the engine – Do not let children operate.

Intended use. Carefully read about and understand the intended use of this engine. Do not use for other purposes, as unforeseen hazards or equipment damage may result.

Never operate, or let anyone else operate the generator while under the influence of alcohol, drugs, or medication.

Do not operate the generator with damaged, missing, or broken parts.

Do not modify the generator in any way. Modifications can create serious safety hazards and will also void the warranty.

Never attempt to modify the generator speed setting. The generator speed is preset for safe and optimal performance of the generator. If speed needs adjusting, it must be done by factory authorised personnel.

Never attempt to connect external fuel sources in order to increase generator run time. Larger tank at pressure or higher elevation will cause to leak from carburetor during operation. Fire or explosion could result.

Always turn off generator and remove spark plug(s) or spark plug wire(s) before working on the generator to prevent accidental starting. Always discharge the capacitor before working on the generator head to prevent electrical shock. (See Maintenance & Repair section of this manual for instructions on how to do this.)

The running of a generator gives off carbon monoxide, a poisonous gas that can kill you. You CAN NOT smell it, see it, or taste it. Follow all instructions for site selection and positioning the generator, and avoid inhaling the exhaust. If you start to feel sick, dizzy, or weak while using the generator, shut off the generator and get to fresh air RIGHT AWAY. See a doctor. You may have carbon monoxide poisoning.

UNPACKING

⚠ CAUTION ⚠

Always have assistance when lifting the generator. The generator is heavy; lifting it could cause bodily harm.

Avoid cutting on or near staples to prevent personal injury.

Tools required - B packing tape on top of the carton.

1. Fold back top flaps to reveal the manual.
2. Remove the Wheel Kit Accessories cardboard box.
3. Carefully cut two sides of the carton to remove the generator.

WHAT COMES IN THE BOX

Manual (1)
Wireless Remote Starter (1) if any
Spark Plug Socket Wrench (1)
Wheel Kit Accessories Box if any
Funnel (1)

WHEEL KIT ACCESSORIES BOX

Open the Wheel Kit Accessories box and verify the contents against the list right. If any parts are missing, please locate an authorised.

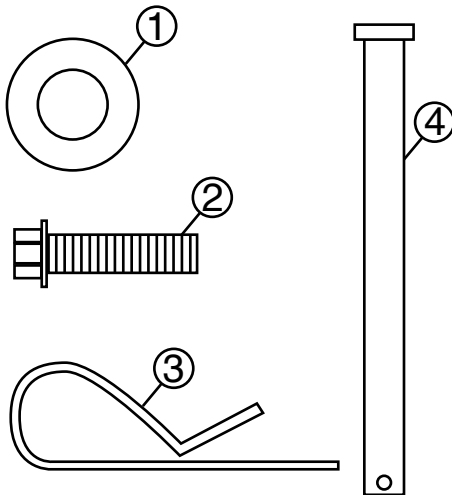

Wheel and Feet Kit Hardware

1. Washer (2 used)
2. Flange Bolt M8 x16mm (4 used)
3. Hairpin Cotter Pin (2 used)
4. Wheel Axle Pin (2)

ASSEMBLY

⚠ CAUTION ⚠

Never lift the generator without assistance. The generator is heavy and lifting without assistance could result in personal injury.

Never use the handles as a lifting point to support the entire weight of the generator. Only use the handles to move the generator by lifting the handles and using the wheels to move the generator.

Use caution when collapsing the handles. Hands and fingers could get caught and pinched.

NOTICE

Assembling the generator will require lifting the unit on one side. Make sure all engine oil and fuel are drained from the unit prior to assembling. Once assembled, the wheel kit is not intended for on-road use. The wheel kit is designed for use on this generator only.

INSTALLING FEET TO FRAME

1. Place generator on a flat surface.
2. Place a piece of cardboard or other soft material to tip the generator onto, to protect the frame paint and prevent the generator from sliding. Tip the generator onto the side.
3. Install the mounting feet to the frame using the M8 flange bolts included.
 - 1 - Mounting Foot
 - 2 - Flange Bolts M8

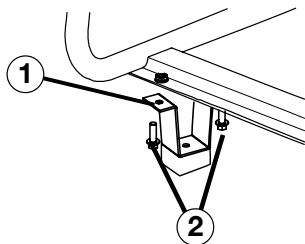

INSTALLING WHEELS TO FRAME

1. Insert axle pin through washer and wheel.

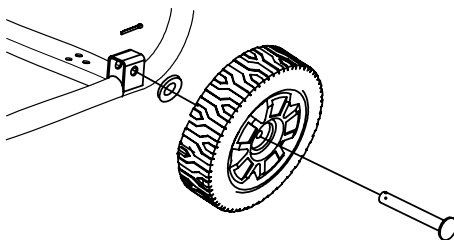
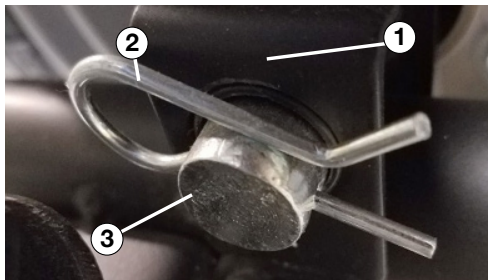

Figure 2 - Wheel Assembly

2. Install the wheel with axle pin through the axle bracket on the frame. The eye of the bolt should be facing toward the inside of the generator.



3. Install the hairpin cotter through the axle pin to lock it in place.
 - 1 - Axle Bracket
 - 2 - Hairpin Clip
 - 3 - Axle Pin
4. Repeat previous steps on other wheel.

ASSEMBLY**⚠ WARNING ⚠**

To avoid electric shock:

- ALWAYS connect the positive (+) battery cable (red boot) first when connecting battery cables.
- ALWAYS disconnect the negative (-) battery cable (black boot) first when disconnecting battery cables.
- NEVER connect the negative (-) battery cable (black boot) to the positive (+) post on the battery.
- NEVER connect the positive (+) battery cable (red boot) to the negative (-) post on the battery.
- NEVER touch both battery posts simultaneously.
- NEVER place a metal tool across both battery posts.
- ALWAYS use insulated or nonconducting tools when installing the battery.

3. Install the hair pin cotter through the axle pin to lock it in place.
 - 1 - Axle Bracket
 - 2 - Hairpin Clip
 - 3 - Axle Pin
4. Repeat previous steps on other wheel.
5. Pull back the black boot and securely attach



Figure 5 - Locating Negative (-) Cable

the negative (-) battery cable (black boot) to the negative (-) battery post as shown in Figure 4. Replace the black boot so it protects the cable lug and battery post.

1. Always make sure to attach the positive (+) battery cable first (1) and then the negative (-) cable second (2) (see Figure 4).



Figure 4 - Battery Connection Order

- 1 - Positive (+) Battery Cable (Red)
- 2 - Negative (-) Battery Cable (Black)

2. Securely tighten the positive (+) battery cable (red boot) to the positive (+) battery post. Make sure boot is over battery post.

NOTICE

The electric start generator is equipped with a battery charging feature. Once the engine is running, a small charge is supplied to the battery via the battery cables and will slowly recharge the battery.

⚠ WARNING ⚠

When you have finished using your generator, ensure you disconnect the positive cable from the battery prior to storage. Failure to do so can cause the battery to discharge resulting in sulfation of battery plates which is not covered under warranty.

OPERATION

LOCATION SELECTION

Before starting the generator, avoid exhaust and location hazards by verifying:

- You have selected a location to operate the generator that is outdoors and well ventilated.
- You have selected a location with a level and solid surface on which to place the generator.
- You have selected a location that is at least 15 feet (4.5 m) away from any building, other equipment or combustible material.
- If the generator is located close to a building, make sure it is not located near any windows, doors and/or vents.

⚠ DANGER ⚠

Using a generator indoors
CAN KILL YOU IN MINUTES.

Generator exhaust contains carbon monoxide.
This is a poison you cannot see or smell.



NEVER use inside a home or garage, **EVEN IF** doors and windows are open.



Only use **OUTSIDE** and far away from windows, doors, and vents.

Avoid other generator hazards.
READ MANUAL BEFORE USE.

⚠ WARNING ⚠

Always operate the generator on a level surface. Placing the generator on non level surfaces can cause the generator to tip over, causing fuel and oil to spill. Spilled fuel can ignite if it comes in contact with an ignition source such as a very hot surface.

HIGH ALTITUDE OPERATION

Engine power is reduced the higher you operate above sea level. Output will be reduced approximately 3.5% for every 1000ft of increased altitude from sea level. This is a natural occurrence and cannot be adjusted by engine. Increased exhaust emissions can also result due to increased fuel mixture. Other issues include hard starting, increased fuel consumption and spark plug fouling.

NOTICE

Only operate the generator on a solid, level surface. Operating the generator on a surface with loose material such as sand or grass clippings can cause debris to be ingested by the generator that could:

- Block cooling vents
- Block air intake system

WEATHER

Never operate your generator outdoors during rain, snow or any combination of weather conditions that could lead to moisture collecting on, in or around the generator.

DRY SURFACE

Always operate the generator on a dry surface free of any moisture.

NO CONNECTED LOADS

Make sure the generator has no connected loads before starting it. To ensure there are no connected loads, unplug any electrical extension cords that are plugged into the control panel receptacles.

NOTICE

Starting the generator with loads already applied to it could result in damage to any appliance being powered off the generator during the brief start-up period.

⚠ WARNING ⚠

Be sure the generator is properly connected to earth ground before operating. The generator must be grounded to prevent electrical shock due to faulty appliances.

OPERATION

CONNECTING THE GENERATOR TO A BUILDING ELECTRICAL SYSTEM

It is recommended to use a manual transfer switch when connecting directly to a buildings electrical system. Connecting a portable generator to a buildings electrical system must be made in strict compliance with all national and local electrical codes and laws, and be completed by a qualified electrician.doors and/or vents.

ADDING / CHECKING ENGINE FLUIDS AND FUEL

⚠ DANGER ⚠



Filling the fuel tank with petrol while the generator is running can cause petrol to leak and come in contact with hot surfaces that can ignite the petrol.

Before starting the generator, always check the level of:

- Engine oil
- Petrol in the fuel tank

Once the generator is started and the engine gets warm, it is not safe to add petrol to the fuel tank or engine oil to the engine while the engine is running or the engine and muffler are hot.

CHECKING AND / OR ADDING ENGINE OIL

⚠ WARNING ⚠

Internal pressure can build in the engine crankcase while the engine is running. Removing the oil fill plug/ dipstick while the engine is hot can cause extremely hot oil to spray out of the crankcase and can severely burn skin. Allow engine oil to cool for several minutes before removing the oil fill plug/ dipstick.

The unit as shipped does not contain oil in the engine. You must add engine oil before starting the generator for the first time.

OPERATION

ADDING PETROL TO THE FUEL TANK

⚠ WARNING ⚠

Never refuel the generator while the engine is running.

Always turn the engine off and allow the generator to cool before refueling.

Required Petrol

Only use petrol that meets the following requirements:

- Unleaded petrol only
- Petrol with maximum 10% ethanol added
- Petrol with an 87 octane rating or higher

Filling the Fuel Tank

Follow the steps below to fill the fuel tank:

1. Shut off the generator.
2. Allow the generator to cool down so all surface areas of the muffler and engine are cool to the touch.
3. Move the generator to a flat surface.
4. Clean area around the fuel cap.
5. Remove the fuel cap by rotating counterclockwise.
6. Slowly add petrol into the fuel tank. Be very careful not to overfill the tank. The petrol level should NOT be higher than the filler neck (see Figure 7).
7. Install the fuel cap by rotating clockwise until you hear a click, indicating the cap is completely installed.

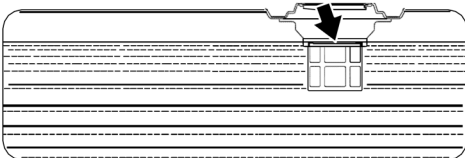

Figure 7 - Maximum Gasoline Fill Level

⚠ CAUTION ⚠

Avoid prolonged skin contact with petrol. Avoid prolonged breathing of petrol vapors.

Before attempting to start the generator, verify the following:

- The engine is filled with engine oil.
- The generator is situated in a proper location.
- The generator is on a dry surface.
- All loads are disconnected from the generator.
- The generator is properly grounded.

⚠ DANGER ⚠

Never use the generator in a location that is wet or damp. Never expose the generator to rain, snow, water spray or standing water while in use. Protect the generator from all hazardous weather conditions. Moisture or ice can cause a short circuit or other malfunction in the electrical circuit.

Never operate the generator in an enclosed area. Engine exhaust contains carbon monoxide. Only operate the generator outside and away from windows, doors and vents.

NOTICE

The engine is equipped with a low oil shutdown switch. If the oil level becomes low, the engine may shut down and not start until the oil is filled to the proper level. Poor oil quality may interfere with the operation of the low oil shutdown switch.

The owner of the generator is responsible to ensure the proper oil level is maintained during the operation of the generator. Failure to maintain the proper oil level can result in engine damage.

Let engine stabilize and warm up for a few minutes before adding load.

OPERATION

GENERATOR SET UP

PLANNING THE POWER LOAD

Plan your power load so that you do not exceed the generator's rated capacity. To calculate the running and starting wattage requirements for the devices you will be powering.

SET UP AS A PORTABLE POWER SOURCE

This generator is designed to provide up to its max power (in watts) of electrical power. When using the generator as a portable power source, you can plug electric devices and appliances directly into the generator's electrical outlets. This generator is equipped with two SAA approved IP66 rated socket outlets.

Make sure you plug each electrical device/appliance into the correct generator outlet based on the device's plug configuration and voltage/amperage rating. Never exceed the amperage rating of an outlet. Note: You must not overload the generator. Overloading may cause serious damage to the generator and attached electrical devices.

SET UP AS A BUILDING BACKUP

For this application, you must arrange for a licensed electrician to connect the generator to your buildings electrical system via the installation of an approved transfer switch. The transfer switch must be installed in accordance with building electrical code and guidelines supplied by your power company.

A transfer switch does the following:

- Safely connects the generator to your building's electrical system by isolating your generator from your utility company's power lines.
- Connects your generator to a critical subset of your building's circuits that are needed for emergency power needs.

DANGER

A transfer switch must be installed in order to isolate your generator from the utility power grid. If your generator is NOT properly isolated from the utility system, serious hazards will arise.

When your generator is running, its output will back feed into the utility power line and transformer that are normally used to provide you with power. The transformer will step up the current to the normal line voltage. An unsuspecting utility line worker working on what he thinks is a deactivated line could be electrocuted.

If your generator is connected (running or not) when utility power is restored, your generator will be destroyed. It could also explode or cause fire.

NOTICE

Regardless of whether you use your generator as a back-up power source connected to a building or as a portable power source, you must not overload the generator. Overloading may cause serious damage to the generator and attached electrical devices.

If your generator will be connected to your building's electrical system, it **MUST ALWAYS** be isolated from the utility power grid with a approved transfer switch installed by a licensed electrician in compliance with all applicable building and electrical codes and in accordance with guidelines supplied by your power company. *continued over page*

OPERATION

NOTICE

There may be Federal or State Occupational Safety and Health Administration (OSHA) regulations, local codes, or ordinances that apply to the intended use of the generator. Please consult a qualified electrician, electrical inspector, or the local agency having jurisdiction.

- In some areas, generators are required to be registered with local utility companies.
- If the generator is used at a construction site, there may be additional regulations that must be observed.

GROUNDING THE GENERATOR

⚠ WARNING ⚠

In order to avoid electrical accidents, all connections to the distribution panel must be carried out by qualified technicians. Incorrect connections can harm people and damage the generator.

Operating the generator when it's not properly grounded can result in electrical shock.

Standard generators are protected by electrical separators. This equipment has a thermic protection device and/or a magne to thermic device to protect against a surge of current, overloading and short-circuiting. In these cases the Generator should under no circumstances be earthed using the terminal "PE" or with any other part of the generator.

If a licensed electrician installs the generator with a connection to your building's electrical circuit for use as a back-up power system, grounding may alternatively be completed through the building's grounding system. Ask your electrician.

⚠ WARNING ⚠

Grounding is not required when the generator is used as a portable power source. Below grounding method is only needed by a qualified electrician if not connecting through your building's electrical system.

If the generator is not grounded through your building's electrical system, follow the procedure below. This procedure can only be carried out by a licensed electrician.

1. Drive a 3/4" or 1" copper pipe or rod into the ground close to the generator. The pipe/rod must penetrate moist earth - the depth required will be dictated by local soil conditions.
2. Connect an approved ground clamp to the pipe.
3. Run a 10 gauge wire from the clamp to the generator grounding post located on the rear of the generator head.
4. Do not connect the generator grounding post to a water pipe or a ground used by a radio system.

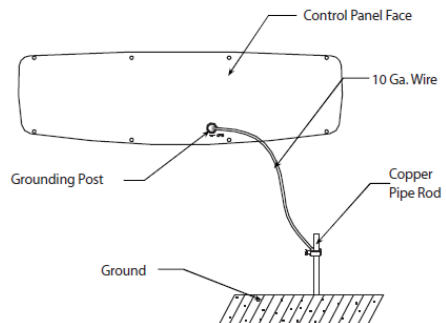

OPERATION

⚠ IMPORTANT ⚠

This generator is fitted with a MEN link cable, the neutral is internally bonded to the generator earth. When a licensed electrician is installing the generator to a building to be used as backup power the MEN must be removed. The MEN link is located is underneath the alternator end cap which is labeled to indicate its location. The MEN link cable clearly labeled as "MEN Link".

EXTENSION CORDS

Extension cords may be used to power devices that are located at a distance from the generator. However, use only Australian approved outdoor - rated, grounded extension cords. Locate the generator in a convenient place and where possible avoid long extension leads and possible damage to leads by pedestrian or vehicular traffic.

Extension leads should be heavy duty with at least 1mm, of appropriate current rating and in any case not less than 1mm cross-section of conductor and must incorporate an earthing conductor to ensure that there is no voltage difference between the generator set and any equipment powered by the generator.

The electrical continuity of the 'earthing' core should be checked periodically from pin to socket to ensure continued electrical safety. Some electrical appliances, e.g. portable drills, are marked or 'double insulated', in which case there should not be an earthing conductor in its mains lead (even though it may have a three-pin plug).

⚠ WARNING ⚠

Use of under sized extension cords can cause electric shock, fire, or damage to connected devices. All extension and appliance cords must be in good condition and not worn, bare, frayed, or otherwise damaged.

Use of damaged electric cords can cause electric shock or fire. Note: If an extension cord becomes hot to the touch, it is overloaded or damaged and must be replaced. ITM is NOT responsible for damage or injury resulting from customer use of inadequate extension cords.

OPERATION

ENGINE SPEED

Engine speed has been factory set to provide safe operation. Tampering with the engine speed adjustment could result in overheating of attachments and could cause a fire.

WARNING

The generator must be run at the correct speed in order to produce the proper electrical voltage and frequency. Failure to do so could result in damage to equipment powered by the generator and possible injury to the individual.

CONNECTING LOADS

You will want to be careful when connecting loads so as not to overload the generator, especially if you are powering devices with motors that require a higher starting power load. Instructions are provided below for connecting loads when you are using the generator as a portable power source.

WARNING

Do not overload generator. Make sure that combined starting and running loads do not exceed rated capacity of generator. Overloading the generator can cause damage to the generator and attached electrical devices and may result in fire.

240V AC CONNECTION

Connect electrical loads one at a time according to the following instructions:

1. Allow engine to reach operating speed by allowing it to warm up for approximately 5 minutes before connecting electrical devices.
2. Check the devices to be connected is turned "OFF" before connecting them to the AC outlets.
3. After engine is warmed up, begin by connecting the items that require the highest wattage first.

The recommended sequence is as follows:

1. Connect items with motors such as refrigerators, freezers, air conditioners, or small hand tools, one at a time.
2. Let each motor stabilize before connecting the next device.
3. Connect any lights you are planning on powering.
4. Connect voltage sensitive equipment such as electronics via surge protectors. Plug devices such as TV's, computers and microwaves into a voltage surge protector, then plug the surge protector into the generator.

12V DC CONNECTION

The generator is fitted with a socket outlet specifically for connection to a lead acid battery for charging. The output voltage is 12V with maximum output current of 8.3A. The generator will charge lead acid batteries of various sizes from small to large.

DO NOT attempt to charge Nicad, Nickel Metal hybrid, or lithium type batteries. ONLY use provided charger cable.

OPERATION

CHARGING A BATTERY

⚠ WARNING ⚠

It's suggested to wear protective clothing, gloves and eye protection when handling and working with lead acid batteries. For operators with pacemakers or similar medical devices and conditions, it is recommended not to attempt the following procedure.

DO NOT attempt to charge a lead acid battery in confined areas. Ensure the charging process takes place in an area where there is fresh air circulating.

Remove the battery from the car, boat or any other device. The battery **MUST** be totally isolated from any other circuitry. After connection to the battery, **RECHECK** to ensure the connections are as below.

- Insert the T-shaped plug to the generator with the opposite end of the cable connected to the battery.
- Connect the positive (+) alligator clip (red) to the positive (+) terminal on the battery.
- Connect the negative (-) alligator clip (black) to the negative (-) terminal on the battery.
- Start the generator and allow the generator to warm up.
- Check the DC reset button is pressed inward (ON position).

The battery charging process is now underway. To disconnect the battery on charge, **STOP THE ENGINE** and remove the plug from the generator socket and disconnect the cable clamps from the battery, in that order.

Note: The battery charging socket should only be used while the 240V AC outlets are **NOT** being used. If the battery was originally in a low level of charge, the battery will take many hours to recharge fully. The time frame will depend on the size of the battery.

⚠ WARNING ⚠

DO NOT leave battery charging unattended. Charging battery for a long period of time can damage the battery once the battery is full.

Over-charging or over-heating can damage the battery, the water and acid solution can boil and leak out of the battery.

OPERATION

⚠ WARNING ⚠

NEVER exceed the rated wattage capacity of your generator. OVERLOADING may cause SERIOUS DAMAGE to the generator and attached electrical devices and may result in fire.

Your generator MUST BE SIZED PROPERLY to provide both the running and starting (surge) wattage of the devices you will be powering. Before using your generator, determine the running and starting wattage requirements of all the electrical devices you will be powering simultaneously. Following below 4 simple steps and example on the right:

- Step 1. Determine the tools and appliances you want to power at the same time
- Step 2. List the start up and running power usage (Watts) for each product
- Step 3. Add the total power usage and add 10% as a safety net
- Step 4. Choose a generator with a rated and maximum power that equals or exceeds your totals. In this case a generator with a rated power of at least 3108W and a maximum power output greater than 7233W would be required.

PRODUCT	RUNNING	START UP
1HP Water Pump	750W	4500W
Lights	75W	75W
Table saw	2000W	2000W
Total	2825W	6575W
+10%	3108W	7233W

STARTING POWER CONSUMPTION

Electronic appliances and brushed motors generally will not draw more than running Watts at start up. Induction motors in equipment like air conditioners, welders, water pumps and compressors can draw 2 to 5 times their running power to start. Please consult your equipment's rating label, manual or the manufacturer to confirm specific requirement. If only the running wattage is given on the nameplate for a device with an electric motor, the starting wattage can be approximated to be three to five times the running wattage. Estimates for the running wattage requirements for common devices are listed in the table below. Guidance for starting wattages is provided in the table's footnotes. To size your generator correctly you need to use Watts - here are some useful calculations:

Watts = Volts x Amps Example 240 Volts x 5 Amps = 1200 Watts

DEVICE	RUNNING WATTS	DEVICE	RUNNING WATTS	DEVICE	RUNNING WATTS
Air conditioner (12,000 BTU)	1700 (a,b)	Freezer	800 (b)	Oven	4500
Battery charger (20 Amp)	500	Hair dryer	1200	Paint sprayer, Airless (1/3 HP)	600 (a)
Belt sander (3")	1000	Hand drill (1")	1100	Paint sprayer, Airless (handheld)	150
Chain saw	1200	Hand drill (3/8")	500	Radio	200
Circular saw(6½")	2000 (a,b)	Hedge trimmer	450	Refrigerator	600 (b)
Coffee maker	1800 (a,b)	Home computer	150	Slow cooker	200
Compressor (1 HP)	1400 (a,b)	Kettle	2400	Submersible pump (1-1/2 HP)	2800 (a)
Compressor (3/4 HP)	1800 (a)	Jet pump	800 (a)	Submersible pump (1 HP)	2000 (a)
Compressor (1/2 HP)	1400 (a)	Lawn mower	1200	Submersible pump (1/2 HP)	1500 (a)
Curling iron	700	Light bulb (100 Watt)	100	Sump pump	600 (a)
Dishwasher	1200	Microwave oven	700	Television	500
Edge trimmer	500	Milk cooler	1100 (a)	Toaster	1000
Electric nail gun	1200	Oil burner on furnace	300	Vacuum cleaner	250
Electric range (1 element)	1500	Oil-red space heater (140,000 Btu)	400	Water heater	3000
Electric skillet	1250	Oil-red space heater (85,000 Btu)	225		
Furnace fan (1/3 HP)	1200 (a)	Oil-red space heater (30,000 Btu)	150		

(a) Hard-starting motors require 3-5 times the rated running watts (b) For extremely hard to start loads such as air conditioners and air compressors, consult the equipment dealer to determine max wattage.

OPERATION

STARTING THE ENGINE

PRE-OPERATION CHECK

1. Check that all shields and covers are in place, and all nuts, bolts, and screws are tightened.
2. Check the engine oil level. Add oil if low. Do not overfill. Running the engine without sufficient oil can cause unreparable damage.



Fill oil to the bottom lip of the dipstick

3. Check fuel level. Add fuel if low (fresh unleaded RON 91 recommended). Starting with a full tank will help to eliminate or reduce operating interruptions for refuelling. Check fuel system components and lines for signs of leak.

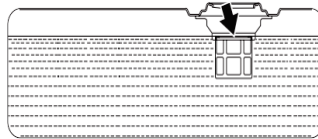
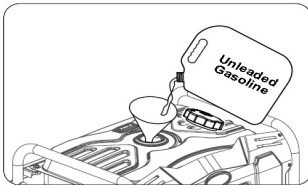

4. Check battery level. If the battery level is unable to start the engine, charge it with the 12V charger included in the package.

OPERATION

ELECTRIC START

Be sure to check oil levels before starting. If it is the first time starting make sure to add oil.

1. Make sure nothing is plugged into power outlets
2. Verify the battery is properly installed and both battery cables are attached.
3. Make sure the circuit breakers are properly set (see Figure 8).

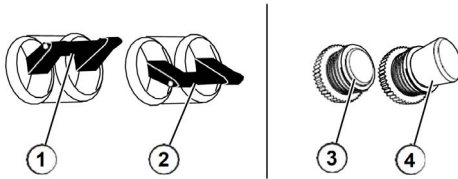

Figure 8 - Breakers

- ① 240/120V Main Circuit Breaker Operating Position
- ② 240/120V Main Circuit Breaker Tripped Position
- ③ 120V Circuit Breaker Operating Position
- ④ 120V Circuit Breaker Tripped Position

4. Move the fuel shutoff valve to the ON position (see Figure 9).

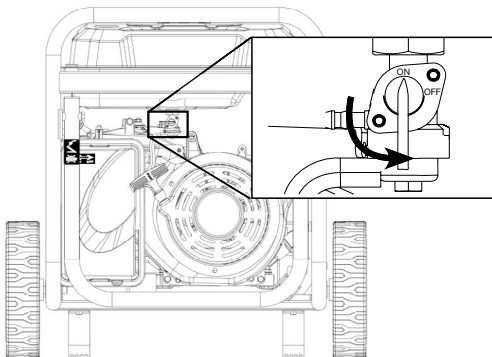

Figure 9 - Fuel Shut Off - ON

5. Push the engine control switch into the RUN position (see Figure 10).

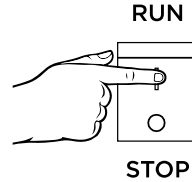

Figure 10 - Engine Control Switch - RUN

6. Push and hold the push button start until the generator starts, then release. If using remote start then hold down START on the remote key fob until the generator starts, then release (see Figure 11).



Figure 11 - Push Button Start/Remote Start

- The engine will automatically set the choke and begin the start sequence.
- If the engine has started successfully the light indicator on the engine start button will turn green.
- If the engine fails to start, the generator controls will attempt to start the engine two more times for a total of three attempts.
- If the third attempt fails, the light on the engine start button will turn red.
- If the engine has failed to start after three attempts the push button start can be pushed again to begin the automatic start sequence.
- The engine control switch can be switched at any time during the automatic start sequence to abort the engine start attempt.

NOTICE

If the cranking speed drops after each unsuccessful attempt, then the battery may not be adequately charged. You can alternatively start the generator using the recoil start as instructed in Manually Starting The Generator on page 20.

7. Plug in electric devices.

OPERATION

MANUALLY STARTING THE GENERATOR

1. Make sure nothing is plugged into power outlets
2. Make sure the circuit breakers are properly set (see Figure 8).
3. Move the fuel shut off valve to the ON position (see Figure 9).
4. 5. Push the engine control switch into the RUN position (see Figure 10).
5. Manually set the choke:
 - a. Cold Start: Close the choke by moving it right towards the front handle of the generator.

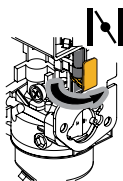

Choke position for cold start.

- b. Warm Start: Open the choke by moving it left towards the wheels of the generator.

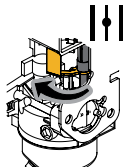

Choke position for warm start.

6. Firmly grasp and pull the recoil handle slowly until you feel increased resistance. At this point, apply a rapid pull while pulling up and slightly away from the generator (see Figure 12).

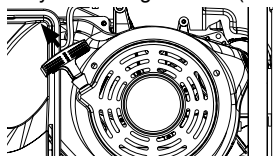

Figure 12 - Pull recoil

7. Plug in electric devices

STOPPING THE GENERATOR

Normal Operation

During normal operation, use the following steps to stop your generator:

1. Remove any connected loads from the control panel receptacles.

2. Allow the generator to run at "no load" to reduce and stabilize engine and alternator temperatures.
3. Choose from options below to stop the generator (see Figure 13):
 - Position the engine control switch to STOP
 - Hold push button start until generator stops
 - Hold the STOP button on the remote start key fob (Note: The generator will run for an additional 15 seconds as it goes through a cool down cycle before shutting off)

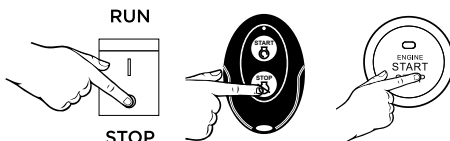

Figure 13 - Stopping the generator

NOTICE

If you plan to store the generator after use, stop the generator by turning the fuel shutoff valve to the OFF position and allow the fuel to be consumed from the carburetor.

4. Turn the fuel shutoff valve to the OFF position.

During an Emergency

If there is an emergency and the generator must be stopped quickly, position the engine control switch to the STOP position immediately.

PROGRAMMING THE GENERATOR FOR REMOTE START

NOTICE

The key fob included with the generator should come already paired with the unit. If it does not you can follow the directions below to reconnect. If your unit was shipped without a key fob please contact our customer support team.

⚠ WARNING ⚠

Always make sure the area around the generator is clear of bystanders before using the remote start to start the generator.

OPERATION

The generator can be started remotely from up to a maximum of 30M away using the remote start key fob with new, fully charged batteries in the key fob. As the batteries' state of charge in the key fob reduces, the distance to start the generator will also reduce.

Before the generator can be started, an initial start-up procedure must be performed so the generator and the key fob recognize each other. If the key fob is replaced, you will need to go through this procedure with the new fob.

1. With the battery connected, turn the engine control switch to the RUN position. The white battery light will illuminate.

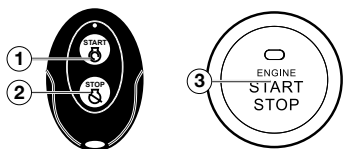

2. Push and hold the red REMOTE PAIRING button on the side of the control panel until the push button start (3) on the control panel illuminates red, then let go. Press this button always until step 3 and 4 finished.
3. Press and hold the STOP (2) button on the remote start key fob until the red light on the push button start (3) goes out, then let go.
4. Press and hold the START (1) button on the remote start key fob until the red light on the push button start (3) goes out, then let go.
5. Press and hold the REMOTE PAIRING button until the red light on the push button start (3) goes out. The generator is now programmed to start remotely.

POWER OUTPUT AND DEMAND

The generator should not be run completely unloaded for extended periods otherwise the engine may be damaged. It is recommended that the generator should always be operated with at least one-third of its rated 120-Volt AC power output. 120-Volt AC devices have two different electric power demands that must be taken into consideration, namely the running power and the starting/peak power. Both are measured in Watts (typically abbreviated as "W").

The steady state continuous load is the running power demand and this is often marked on the device near its model number or serial number. Sometimes the device might only be marked with its voltage (i.e. 120 V) and current draw (e.g. 6 Amp or 6 A), in which case the running power demand in Watts can be obtained by multiplying the voltage times the current, e.g. $120\text{ V} \times 20\text{ A} = 2,400\text{ W}$.

Simple resistive 120-Volt AC devices such as incandescent bulbs, toasters, heaters, etc. have no extra power demand when starting, and so their starting power demands are the same as their running power demands.

More complex 120-Volt AC devices containing inductive or capacitive elements such as electric motors have a momentary extra power demand when starting, which can be up to seven times the running power demand or more. Manufacturers of such devices rarely publish this starting power demand and so it's often necessary to estimate it. A rule of thumb for devices fitted with an electric motor is to apply a starting power multiplier of 1.2 for small hand-held or portable devices and a value of 3.5 for larger stationary devices. For example, a 900 W angle grinder can be assumed to have a starting power demand of at least $1.2 \times 900\text{ W}$, which equals 1,080 W. Similarly, a 1,650 W air compressor can be assumed to have a starting power demand of at least $3.5 \times 1,650\text{ W}$, which equals 5,775 W.

To prevent overloading of the generator's 120-Volt AC system:

1. Add up the running power demand of all the 120-Volt AC devices that will be connected to the generator at one time. This total must not be greater than the generator's specified running power output.
2. Add up the running power demand again, but for the largest motor-driven device use the value of its starting power demand instead of its running power demand. This total must not be greater than the generator's specified starting power output.
3. The total running power demand of all the devices that will be connected to any one of the generator's outlets must not exceed the generator's specified running power output or 3,700 W, whichever is the lesser.

MAINTENANCE

MAINTENANCE SCHEDULE - AUTHORISED ITM SERVICE DEALER PERFORMED

Maintenance Item	After 100 Hour of Use or Every 6 Months	After 300 Hours of Use or Every Year
Valve Clearance	-	Check/Adjust
Fuel Filter	Check/Adjust	-
Idle Speed	-	Check/Adjust

CLEAN & INSPECT SPARK ARRESTOR

Depending on the fuel used, the type and the amount of lubricant used, and/or your operating conditions, the exhaust part and muffler may become blocked with carbon deposits. If you notice power loss, you may need to remove these deposits to restore performance.

- Allow the engine to cool complete before servicing the spark arrestor.
- Remove the spark arrestor, check and clean with a wire brush.
- Replace spark arrestor if it's damaged.

2. If the spark arrestor screen shows signs of wear (rips, tears or large openings in the screen), replace the spark arrestor screen. If screen is not torn then clean using a wire brush, commercial solvent, or compressed air. Remove any dirt and debris that may have collected on the spark arrestor screen (see Figure 16).

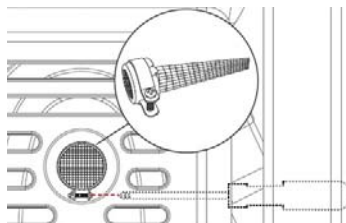

1. Once the cover is removed, locate the screw on the tip of the muffler and remove. Pull the spark arrestor out of the muffler. (see Figure 15).

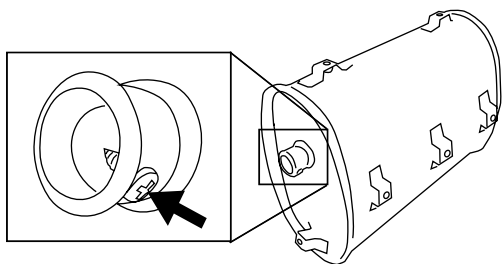

Figure 15: Remove spark arrestor

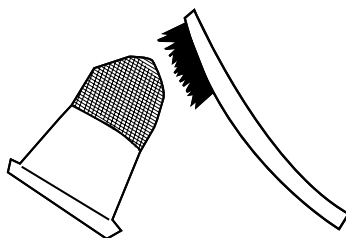
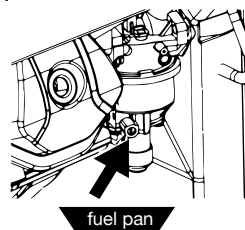

Figure 16: Clean spark arrestor

3. Install the spark arrestor back into the muffler. Make sure to fully push it in so that it is tight on the tip of the muffler.
4. Replace the muffler cover and tighten all 6 screws.

DRAINING CARBURETOR FLOAT BOWL

1. Make sure the generator is off and you are away from any open flames.
2. Place pan (or suitable container) under the carburetor assembly.
3. Loosen screw at bottom of the bowl and allow gas to drain out.
4. After all the gas has drained out, tighten the screw.



fuel pan

MAINTENANCE

ENGINE OIL MAINTENANCE

Engine Oil Specification

1. Only use the engine oil specified in Figure 17.
2. Only use 4-stroke/cycle engine oil. NEVER USE 2-STROKE/CYCLE OIL. Synthetic oil is an acceptable substitute for conventional oil.

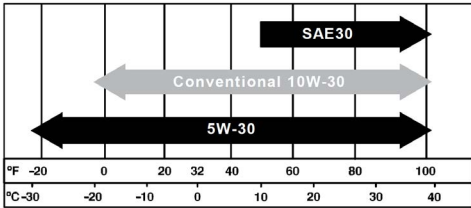

Figure 17 - Recommended Oil

NOTICE

Always maintain proper engine oil level. Failure to maintain proper engine oil level could result in severe damage to the engine and/or shorten the life of the engine. Always use the specified engine oil. Failure to use the specified engine oil can cause accelerated wear and/or shorten the life of the engine.

Engine oil level should be checked before every use.

1. Always operate or maintain the generator on a flat surface.
2. Stop engine if running.
3. Let engine sit and cool for several minutes (allow crankcase pressure to equalise).
4. With a damp rag, clean around the oil fill plug/dipstick.
5. Remove oil fill plug/dipstick (see Figure 18 below).

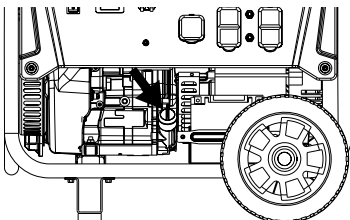

Figure 18 - Oil Fill Plug/Dipstick

6. Check oil level: When checking the engine oil, remove the oil fill plug/dipstick and wipe it clean. Thread the oil fill plug/dipstick all the way back in and then remove and check the oil level on the oil fill plug/dipstick.
7. **Acceptable Oil Level** - Oil is visible on the crosshatches between the H and L lines on the oil fill plug/dipstick (see Figure 19).
8. **Low Oil** - Oil is below the L line on the oil fill plug/dipstick.

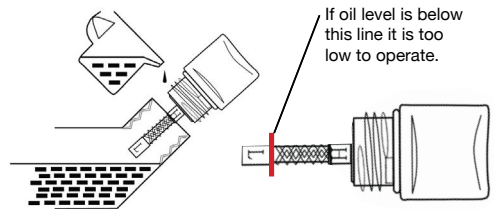

Figure 19 - Checking Oil Level

ADDING ENGINE OIL

1. Always operate or maintain the generator on a flat surface.
2. Stop engine if running.
3. Let engine sit and cool for several minutes (allow crankcase pressure to equalise).
4. Thoroughly clean around the oil fill plug/dipstick.
5. Remove oil fill plug/dipstick and wipe clean.
6. Select the proper engine oil as specified in Figure 17.
7. Using the supplied funnel, slowly add engine oil to the engine. Stop frequently to check the level to avoid overfilling.
8. Continue to add oil until the oil is at the correct level. See Figure 19.
9. Replace the oil fill plug/dipstick.

MAINTENANCE

CHANGING ENGINE OIL

1. Always operate or maintain the generator on a flat surface.
2. Stop the engine.
3. Let engine sit and cool for several minutes (allow crankcase pressure to equalise).
4. Place oil pan (or suitable container) under the oil drain plug (see Figure 20).
5. With a damp rag, thoroughly clean around the oil drain plug.
6. Remove the oil drain plug (see Figure 20). Once removed, place the oil drain plug on a clean surface.

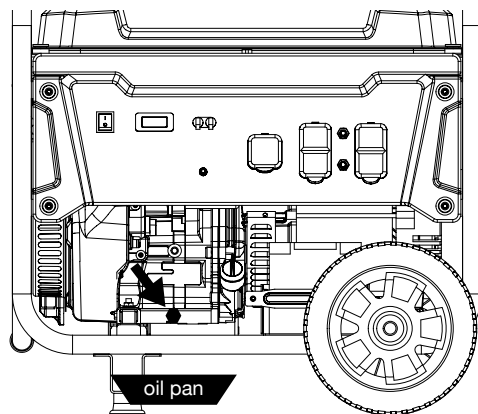

Figure 20 - Oil Drain Plug

7. Allow oil to completely drain.
8. Replace oil drain plug.
9. Fill crankcase with oil following the steps outlined in Adding Engine Oil on page 23.

NOTICE

Never dispose of used engine oil by dumping the oil into a sewer, on the ground, or into ground water or waterways. Always be environmentally responsible. Follow the guidelines of the EPA or other governmental agencies for proper disposal of hazardous materials. Consult local authorities or reclamation facility.

⚠ WARNING ⚠

Never use petrol or other flammable solvents to clean the air filter. Use only household detergent soap to clean the air filter.

Cleaning the Air Filter

The air filter must be cleaned after every 50 hours of use or 3 months (frequency should be increased if generator is operated in a dusty environment).

1. Turn off the generator and let it cool for several minutes if running.
2. Move the generator to a flat, level surface.
3. Unclip the clips on the top and bottom of the air filter cover (Figure 21).

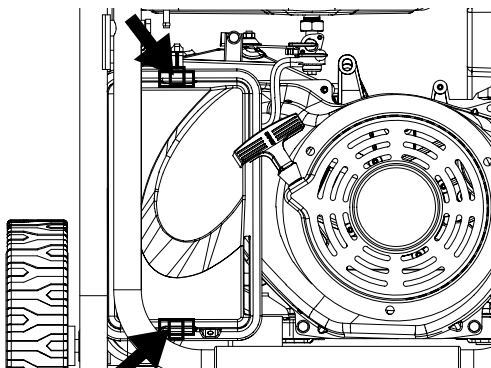

Figure 21 - Unclip air filter

4. Remove the black coarse air filters.
5. Wash the foam air filter elements by submerging the elements in a solution of household detergent soap and warm water. Slowly squeeze the foam to thoroughly clean.

NOTICE

NEVER twist or tear the foam air filter element during cleaning or drying. Only apply slow but firm squeezing action.

6. Rinse in clean water by submerging the air filter elements in fresh water and applying a slow squeezing action.

MAINTENANCE**NOTICE**

Never dispose of soap cleaning solution used to clean the air filter by dumping the solution into a sewer, on the ground, or into ground water or waterways. Always be environmentally responsible. Follow the guidelines of the EPA or other governmental agencies for proper disposal of hazardous materials. Consult local authorities or reclamation facility.

7. Dispose of used soap cleaning solution properly.
8. Dry the air filter elements by again applying a slow firm squeezing action.
9. Once the air filters are dry, coat the air filters with clean engine oil (see Figure 22).

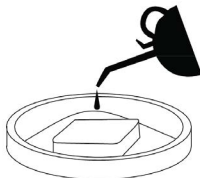

Figure 22

10. Squeeze the filters to remove any excess oil.
11. Install the filters back into the unit. Make sure the gray (fine) air filter goes in first followed by the black (coarse) air filter on the outside.
12. Install the air filter cover and secure the air filter assembly.

SPARK PLUG MAINTENANCE

The spark plug must be checked and cleaned after every 100 hours of use or 6 months and must be replaced after 300 hours of use or every year.

1. Stop the generator and let it cool for several minutes if running.
2. Move the generator to a flat, level surface.
3. Remove the spark plug boot by firmly pulling the plastic spark plug boot handle directly away from the engine (see Figure 23).

NOTICE

Never apply any side load or move the spark plug laterally when removing the spark plug. Applying a side load or moving the spark plug laterally may crack and damage the spark plug boot.

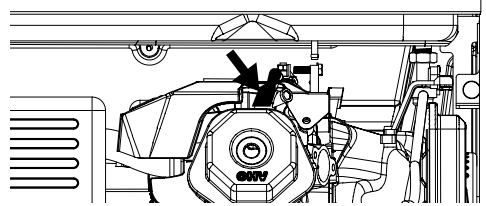
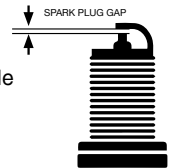

Figure 23 - Remove Spark Plug Boot

4. Clean area around the spark plug.
5. Using the 13/16" spark plug socket wrench provided, remove the spark plug from the cylinder head.
6. Place a clean rag over the opening created by the removal of the spark plug to make sure no dirt can get into the combustion chamber. Inspect the spark plug for:
 - Cracked or chipped insulator
 - Excessive wear
 - Spark plug gap (the acceptable limit of 0.027–0.032 in. [0.70 – 0.80 mm]).

**NOTICE**

Use only recommended spark plugs when servicing. The manufacturer is not responsible for engine damage when using spark plugs not recommended by the manufacturer.

7. Install the spark plug by carefully following the steps outlined below:
 - a. Carefully insert the spark plug back into the cylinder head. Hand-thread the spark plug until it bottoms out.
 - b. Using the 13/16" spark plug socket wrench provided, turn the spark plug to ensure it is fully seated.
 - c. Replace the spark plug boot, making sure the boot fully engages the spark plug's tip.

Recommended Spark Plug Replacement:
 NGK: (1034) BP7ES (Replacement)
 Torch: F7TC (OE Spark Plug)

MAINTENANCE

CHECKING AND ADJUSTING VALVE LASH

⚠ CAUTION ⚠

Checking and adjusting valve lash must be done when the engine is cold.

1. Remove the rocker arm cover and carefully remove the gasket. If the gasket is torn or damaged, it must be replaced.
2. Remove the spark plug so the engine can be rotated more easily.
3. Rotate the engine to top dead centre (TDC) of the compression stroke. Looking through the spark plug hole, the piston should be at the top.
4. Both the rocker arms should be loose at TDC on the compression stroke. If they are not, rotate the engine 360°.
5. Insert a feeler gauge between the rocker arm and the push rod and check for clearance (see Figure 24). See Table 3 for valve lash specifications.

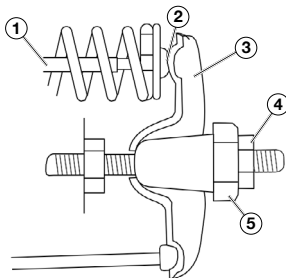

Figure 24
(1) Push Rod, (2) Feeler Gauge Area
(3) Rocker Arm, (4) Jam Nut, (5) Adjusting Nut

	Intake Valve	Exhaust Valve
Valve Lash	0.0035 ± 0.0043 in (0.09 ± 0.11 mm)	0.0043 ± 0.0051 in (0.11 ± 0.13 mm)
Bolt Torque	8-12 Nm	8-12 Nm

6. If an adjustment is required, hold the adjusting nut and loosen the jam nut.
7. Turn the adjusting nut to obtain the correct valve lash. When the valve lash is correct, hold the adjusting nut and tighten the jam nut to 106 in-lb (12 Nm).
8. Recheck the valve lash after tightening the jam nut.
9. Perform this procedure for both the intake and exhaust valves.
10. Install the rocker arm cover, gasket and spark plug.

BATTERY SERVICE

⚠ WARNING ⚠

Do not charge for over 8 hours. Leaving the charger plugged in indefinitely could overcharge the battery and lead to battery failure.

To ensure the battery remains charged, the generator should be started every 2 to 3 months and run for a minimum of 15 minutes or a charger should be plugged into the generator and the generator should be charged overnight. Make sure the positive and negative leads are disconnected from the battery. Connect the lead from the charger to the corresponding terminals on the battery and plug the charger into a 240V power outlet.

⚠ WARNING ⚠

When storing the generator for extended periods, to reduce the chance of completely draining the battery power ensure the leads are disconnected from the battery.

MAINTENANCE

BATTERY REPLACEMENT

1. Remove the spark plug wire from spark plug.
2. Loosen and remove the bolt on the battery hold down plate and swing the plate out.
3. Tip the battery forward slightly to access battery cables.
4. Disconnect the black negative (-) battery cable from the battery first.
5. Disconnect the red positive (+) battery cable second and remove the battery.

NOTICE

Never apply any side load or move the spark plug laterally when removing the spark plug. Applying a side load or moving the spark plug laterally may crack and damage the spark plug boot.

6. Install the new battery into the generator frame. Battery must meet specifications in table below to work properly.
7. Connect the red positive (+) battery cable to the battery first.
8. Connect the black negative (-) battery cable to the battery second.
9. Install the battery hold-down plate using the nuts removed in step 2.
10. Install the spark plug wire onto spark plug.

CLEANING THE GENERATOR

It is important to inspect and clean the generator after every use.

Clean All Engine Air Inlet and Outlet Ports

Make sure all engine air inlet and outlet ports are clean of any dirt and debris to ensure the engine does not run hot.

Clean All Engine Cooling Fins

Use a damp rag and a brush to loosen and remove all dirt on or around the engine's cooling fins.

Clean All Alternator Cooling Air Inlets and Exhaust Ports

Make sure the cooling air inlets and exhaust ports of the alternator are free of any debris and obstructions. Use a vacuum cleaner to remove dirt and debris stuck in the cooling air inlets and exhaust ports.

General Cleaning of the Generator

Use a damp rag to clean all remaining surfaces.

STORING THE GENERATOR

⚠ WARNING ⚠

Never store a generator with fuel in the tank indoors or in a poorly ventilated area where the fumes can come in contact with an ignition source. Always disconnect the positive cable from the battery prior to storage.

NOTICE

Petrol stored for as little as 60 days can go bad, causing gum, varnish and corrosive buildup in fuel lines, fuel passages and the engine. This corrosive buildup restricts the flow of fuel, preventing an engine from starting after a prolonged storage period.

Proper care should be taken to prepare the generator for any storage.

1. Make sure the Engine Switch is switched to STOP so the generator does not draw power from battery.
2. Clean the generator as outlined in Cleaning the Generator.
3. Drain all petrol from the fuel tank as best as possible.
4. With the fuel shut off valve open, start the engine and allow the generator to run until all the remaining petrol in the fuel lines and carburetor is consumed and the engine shuts off.
5. Close the fuel shut off valve.
6. Drain the remaining gas in the carburetor float bowl outlined in Draining Carburetor Float Bowl on page 22.
7. Change the oil (see Changing Engine Oil on page 24).
8. Remove the spark plug (see Spark Plug Maintenance on page 25) and place about 1 tablespoon of oil in the spark plug opening. While placing a clean rag over the spark plug opening, slowly pull there coil handle to allow the engine to turn over several times. This will distribute the oil and protect the cylinder wall from corroding during storage.
9. Replace the spark plug (see Spark Plug Maintenance on page 25).
10. Move the generator to a clean, dry place for storage.

TROUBLE SHOOTING

⚠ WARNING ⚠

Before attempting to service or troubleshoot the generator, the owner or service technician must first read the owner's manual and understand and follow all safety instructions. Failure to follow all instructions may result in conditions that can lead to voiding of the EPA certification or product warranty, serious personal injury, property damage or even death.

PROBLEM	POTENTIAL CAUSE	SOLUTION
Engine is running, but no electrical output	1. Circuit breakers are tripped.	1. Reset the circuit breakers and check for overload condition.
	2. The power cord's plug connector is not fully engaged in the generator's outlet.	2. Verify plug connector is firmly engaged in the generator's outlet. If using the 240V outlet, make sure plug connector is rotated 1/4 turn in the clockwise direction.
	3. Faulty or defective power cord	3. Replace power cord.
	4. Faulty or defective electrical appliance	4. Try connecting a known good appliance to verify the generator is producing electrical power.
	5. GFCI outlet is tripped	5. Press the reset button on the GFCI outlet.
	6. If trying 1-5 above does not solve the problem, the cause might be the generator has a fault.	6. Take the generator to your nearest authorised service dealer.
Engine will not start or remain running while trying to start.	1. Fuel shutoff valve is in the OFF position.	1. Move the fuel shut off valve to the ON position.
	2. Generator is out of petrol.	2. Add petrol to the generator.
	3. Fuel flow is obstructed.	3. Inspect and clean fuel delivery passages.
	4. Starting battery may have insufficient charge	4. On electric start models only. Check battery output and charge battery as necessary.
	5. Dirty air filter	5. Check and clean the air filter.
	6. Low oil level shut down switch is preventing the unit from starting.	6. Check oil level and add oil if necessary.
	7. Spark plug boot is not fully engaged with the spark plug tip.	7. Firmly push down on the spark plug boot to ensure the boot is fully engaged
	8. Spark plug is faulty.	8. Remove and check the spark plug. Replace if faulty.
	9. Dirty/plugged spark arrester	9. Check and clean the spark arrester.
	10. Stale fuel	10. Drain fuel and replace with fresh fuel.
	11. If trying 1-11 above does not solve the problem, the cause might be the generator has a fault.	11. Take the generator to your nearest authorised service dealer.
Generator suddenly stops running.	1. Generator is out of fuel.	1. Check fuel level. Add fuel if necessary.
	2. The low oil shut down switch has stopped the engine.	2. Check oil level and add oil if necessary.
	3. Too much load	3. Restart the generator and reduce the load.
	4. If trying 1-3 above does not solve the problem, the cause might be a fault in the generator.	4. Take the generator to your nearest authorised service dealer.
Engine runs erratic; does not hold a steady RPM.	1. Dirty air filter	1. Clean the air filter.
	2. Applied loads maybe cycling on and off	2. As applied loads cycle, changes in engine speed may occur; this is a normal condition.
	3. If trying 1-3 above does not solve the problem, the cause might be a fault in the generator	3. Take the generator to your nearest authorised service dealer.

ITEM NUMBER	DESCRIPTION	QUANTITY
1	FRAME	1
2	ROTOR END A	2
3	ROTOR END B	2
4	WHEEL	2
5	WHEEL NUT	4
6	WHEEL WASH	2
7	WHEEL WASH BRUSH	2
8	WHEEL WASH BRUSH BRUSH	2
9	WHEEL WASH BRUSH BRUSH	2
10	WHEEL WASH BRUSH BRUSH	2
11	WHEEL WASH BRUSH BRUSH	2
12	WHEEL WASH BRUSH BRUSH	2
13	WHEEL WASH BRUSH BRUSH	2
14	WHEEL WASH BRUSH BRUSH	2
15	WHEEL WASH BRUSH BRUSH	2
16	WHEEL WASH BRUSH BRUSH	2
17	WHEEL WASH BRUSH BRUSH	2
18	WHEEL WASH BRUSH BRUSH	2
19	WHEEL WASH BRUSH BRUSH	2
20	WHEEL WASH BRUSH BRUSH	2
21	WHEEL WASH BRUSH BRUSH	2
22	WHEEL WASH BRUSH BRUSH	2
23	WHEEL WASH BRUSH BRUSH	2
24	WHEEL WASH BRUSH BRUSH	2
25	WHEEL WASH BRUSH BRUSH	2
26	WHEEL WASH BRUSH BRUSH	2
27	WHEEL WASH BRUSH BRUSH	2
28	WHEEL WASH BRUSH BRUSH	2
29	WHEEL WASH BRUSH BRUSH	2
30	WHEEL WASH BRUSH BRUSH	2
31	WHEEL WASH BRUSH BRUSH	2
32	WHEEL WASH BRUSH BRUSH	2
33	WHEEL WASH BRUSH BRUSH	2
34	WHEEL WASH BRUSH BRUSH	2
35	WHEEL WASH BRUSH BRUSH	2
36	WHEEL WASH BRUSH BRUSH	2
37	WHEEL WASH BRUSH BRUSH	2
38	WHEEL WASH BRUSH BRUSH	2
39	WHEEL WASH BRUSH BRUSH	2
40	WHEEL WASH BRUSH BRUSH	2
41	WHEEL WASH BRUSH BRUSH	2
42	WHEEL WASH BRUSH BRUSH	2
43	WHEEL WASH BRUSH BRUSH	2
44	WHEEL WASH BRUSH BRUSH	2
45	WHEEL WASH BRUSH BRUSH	2
46	WHEEL WASH BRUSH BRUSH	2
47	WHEEL WASH BRUSH BRUSH	2
48	WHEEL WASH BRUSH BRUSH	2
49	WHEEL WASH BRUSH BRUSH	2
50	WHEEL WASH BRUSH BRUSH	2
51	WHEEL WASH BRUSH BRUSH	2
52	WHEEL WASH BRUSH BRUSH	2
53	WHEEL WASH BRUSH BRUSH	2
54	WHEEL WASH BRUSH BRUSH	2
55	WHEEL WASH BRUSH BRUSH	2
56	WHEEL WASH BRUSH BRUSH	2
57	WHEEL WASH BRUSH BRUSH	2
58	WHEEL WASH BRUSH BRUSH	2
59	WHEEL WASH BRUSH BRUSH	2
60	WHEEL WASH BRUSH BRUSH	2
61	WHEEL WASH BRUSH BRUSH	2
62	WHEEL WASH BRUSH BRUSH	2
63	WHEEL WASH BRUSH BRUSH	2
64	WHEEL WASH BRUSH BRUSH	2
65	WHEEL WASH BRUSH BRUSH	2
66	WHEEL WASH BRUSH BRUSH	2
67	WHEEL WASH BRUSH BRUSH	2
68	WHEEL WASH BRUSH BRUSH	2
69	WHEEL WASH BRUSH BRUSH	2
70	WHEEL WASH BRUSH BRUSH	2
71	WHEEL WASH BRUSH BRUSH	2
72	WHEEL WASH BRUSH BRUSH	2
73	WHEEL WASH BRUSH BRUSH	2
74	WHEEL WASH BRUSH BRUSH	2
75	WHEEL WASH BRUSH BRUSH	2
76	WHEEL WASH BRUSH BRUSH	2
77	WHEEL WASH BRUSH BRUSH	2
78	WHEEL WASH BRUSH BRUSH	2
79	WHEEL WASH BRUSH BRUSH	2
80	WHEEL WASH BRUSH BRUSH	2
81	WHEEL WASH BRUSH BRUSH	2
82	WHEEL WASH BRUSH BRUSH	2
83	WHEEL WASH BRUSH BRUSH	2
84	WHEEL WASH BRUSH BRUSH	2
85	WHEEL WASH BRUSH BRUSH	2
86	WHEEL WASH BRUSH BRUSH	2
87	WHEEL WASH BRUSH BRUSH	2
88	WHEEL WASH BRUSH BRUSH	2
89	WHEEL WASH BRUSH BRUSH	2
90	WHEEL WASH BRUSH BRUSH	2
91	WHEEL WASH BRUSH BRUSH	2
92	WHEEL WASH BRUSH BRUSH	2
93	WHEEL WASH BRUSH BRUSH	2
94	WHEEL WASH BRUSH BRUSH	2
95	WHEEL WASH BRUSH BRUSH	2
96	WHEEL WASH BRUSH BRUSH	2
97	WHEEL WASH BRUSH BRUSH	2
98	WHEEL WASH BRUSH BRUSH	2
99	WHEEL WASH BRUSH BRUSH	2
100	WHEEL WASH BRUSH BRUSH	2

Generator Parts List
Part No. **TM520-3400**

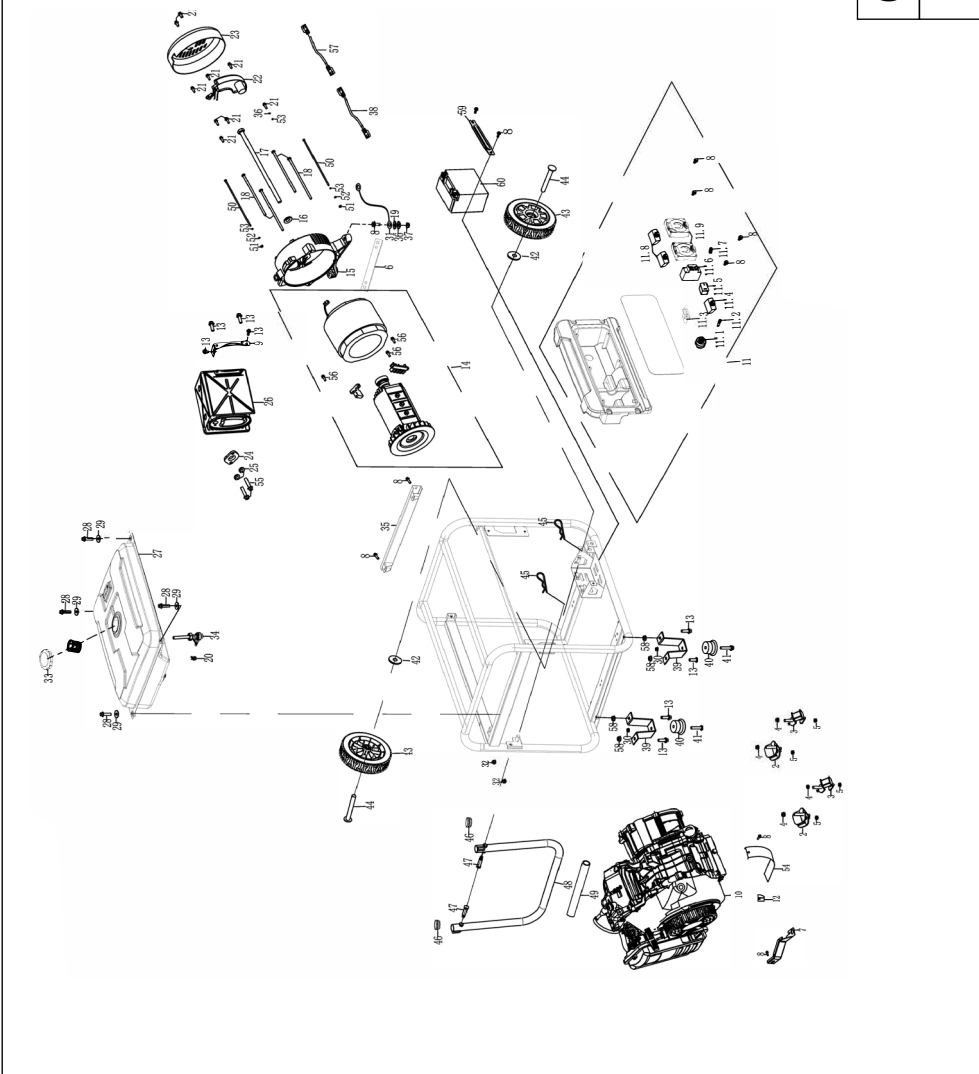

102	100K	SPRINT	1
1	100K	SPRINT	1
2	100K	SPRINT	1
3	100K	SPRINT	1
4	100K	SPRINT	1
5	100K	SPRINT	1
6	100K	SPRINT	1
7	100K	SPRINT	1
8	100K	SPRINT	1
9	100K	SPRINT	1
10	100K	SPRINT	1
11	100K	SPRINT	1
12	100K	SPRINT	1
13	100K	SPRINT	1
14	100K	SPRINT	1
15	100K	SPRINT	1
16	100K	SPRINT	1
17	100K	SPRINT	1
18	100K	SPRINT	1
19	100K	SPRINT	1
20	100K	SPRINT	1
21	100K	SPRINT	1
22	100K	SPRINT	1
23	100K	SPRINT	1
24	100K	SPRINT	1
25	100K	SPRINT	1
26	100K	SPRINT	1
27	100K	SPRINT	1
28	100K	SPRINT	1
29	100K	SPRINT	1
30	100K	SPRINT	1
31	100K	SPRINT	1
32	100K	SPRINT	1
33	100K	SPRINT	1
34	100K	SPRINT	1
35	100K	SPRINT	1
36	100K	SPRINT	1
37	100K	SPRINT	1
38	100K	SPRINT	1
39	100K	SPRINT	1
40	100K	SPRINT	1
41	100K	SPRINT	1
42	100K	SPRINT	1
43	100K	SPRINT	1
44	100K	SPRINT	1
45	100K	SPRINT	1
46	100K	SPRINT	1
47	100K	SPRINT	1
48	100K	SPRINT	1
49	100K	SPRINT	1
50	100K	SPRINT	1
51	100K	SPRINT	1
52	100K	SPRINT	1
53	100K	SPRINT	1
54	100K	SPRINT	1
55	100K	SPRINT	1
56	100K	SPRINT	1
57	100K	SPRINT	1
58	100K	SPRINT	1
59	100K	SPRINT	1
60	100K	SPRINT	1
61	100K	SPRINT	1
62	100K	SPRINT	1
63	100K	SPRINT	1
64	100K	SPRINT	1
65	100K	SPRINT	1
66	100K	SPRINT	1
67	100K	SPRINT	1
68	100K	SPRINT	1
69	100K	SPRINT	1
70	100K	SPRINT	1
71	100K	SPRINT	1
72	100K	SPRINT	1
73	100K	SPRINT	1
74	100K	SPRINT	1
75	100K	SPRINT	1
76	100K	SPRINT	1
77	100K	SPRINT	1
78	100K	SPRINT	1
79	100K	SPRINT	1
80	100K	SPRINT	1
81	100K	SPRINT	1
82	100K	SPRINT	1
83	100K	SPRINT	1
84	100K	SPRINT	1
85	100K	SPRINT	1
86	100K	SPRINT	1
87	100K	SPRINT	1
88	100K	SPRINT	1
89	100K	SPRINT	1
90	100K	SPRINT	1
91	100K	SPRINT	1
92	100K	SPRINT	1
93	100K	SPRINT	1
94	100K	SPRINT	1
95	100K	SPRINT	1
96	100K	SPRINT	1
97	100K	SPRINT	1
98	100K	SPRINT	1
99	100K	SPRINT	1
100	100K	SPRINT	1

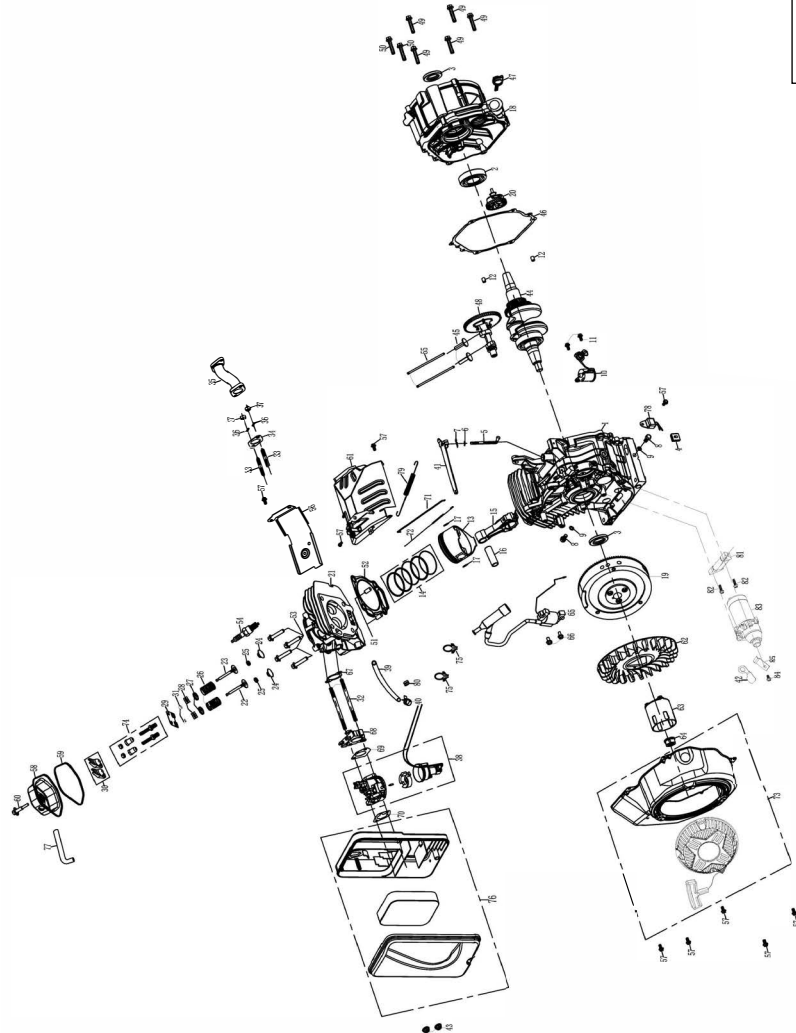

Engine Breakdown

Part No.
TM520-5500



NO.	QTY	DESCRIPTION	QTY
1	1	STARTING MOTOR ASSEMBLY	1
2	1	STARTER SHAFT	1
3	1	ROCK	2
4	1	NUT #6	2
5	1	FLAT WASHER #6	2
6	1	WASHER #6	2
7	1	FRAME	1
8	1	SEPARATOR	2
9	1	CLUTCH	2
10	1	CLUTCH B	2
11	1	PANEL WANK ASSEMBLY	1
12	1	FUEL COOK	1
13	1	COX	1
14	1	DISCHARGE SHEET	1
15	1	WATER COOLING CASE	1
16	1	FLAT WASHER #10	1
17	1	FLAT WASHER #10	1
18	1	WASHER #10	1
19	1	ROTOR BOLT	1
20	1	ROTOR BOLT	1
21	1	ROTOR BOLT	1
22	1	ROTOR BOLT	1
23	1	ROTOR BOLT	1
24	1	ROTOR BOLT	1
25	1	NUT #10	1
26	1	GASSET EXHAUST PIPE	1
27	1	ROTOR BOLT	1
28	1	SPRING WASHER #8	2
29	1	ROTOR BOLT	2
30	1	ROTOR BOLT	2
31	1	ROTOR BOLT	4
32	1	PANEL COMP	1
33	1	ELECTRIC LOCK	1
34	1	ELECTRIC LOCK	1
35	1	THE ACCUMULATOR	1
36	1	HEATMA PROTECTOR	1
37	1	AC SWAN SOCKET	2
38	1	FRONT DOOR ASSEMBLY	1
39	1	WHEEL LEADGE OPEN	1
40	1	WHEEL LEADGE OPEN	1
41	1	AUTOMATIC VOLTAGE REGULATOR	1
42	1	WASHER #10	3
43	1	WASHER #10	4
44	1	WASHER #10	4
45	1	WASHER #10	1
46	1	WASHER #10	1
47	1	WASHER #10	1
48	1	WASHER #10	1
49	1	WASHER #10	1
50	1	WASHER #10	1
51	1	WASHER #10	1
52	1	WASHER #10	1
53	1	WASHER #10	1
54	1	WASHER #10	1
55	1	WASHER #10	1
56	1	WASHER #10	1
57	1	WASHER #10	1
58	1	WASHER #10	1
59	1	WASHER #10	1

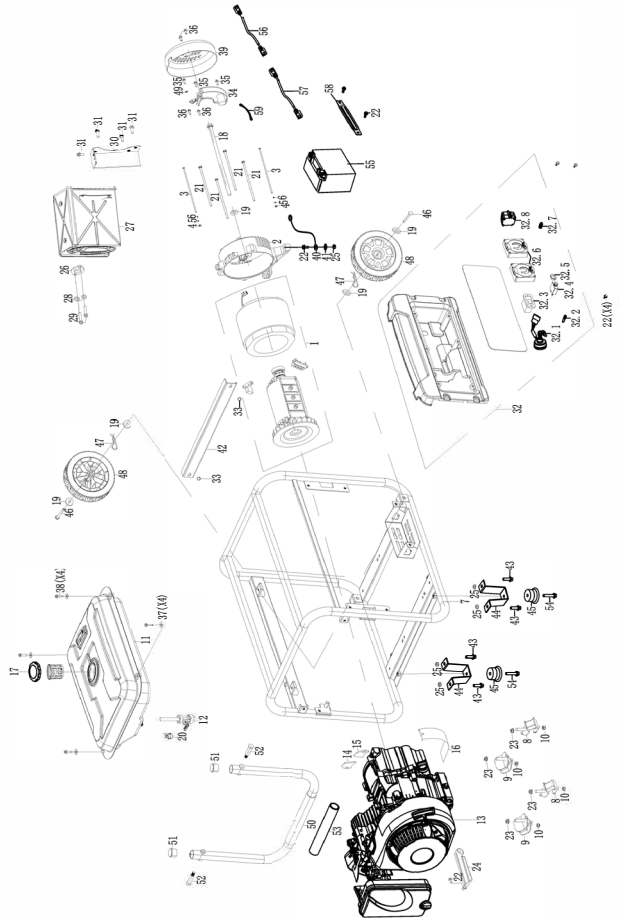

Generator Parts List

Part No.
TM520-5500



100	COVER
101	COVER
102	COVER
103	COVER
104	COVER
105	COVER
106	COVER
107	COVER
108	COVER
109	COVER
110	COVER
111	COVER
112	COVER
113	COVER
114	COVER
115	COVER
116	COVER
117	COVER
118	COVER
119	COVER
120	COVER
121	COVER
122	COVER
123	COVER
124	COVER
125	COVER
126	COVER
127	COVER
128	COVER
129	COVER
130	COVER
131	COVER
132	COVER
133	COVER
134	COVER
135	COVER
136	COVER
137	COVER
138	COVER
139	COVER
140	COVER
141	COVER
142	COVER
143	COVER
144	COVER
145	COVER
146	COVER
147	COVER
148	COVER
149	COVER
150	COVER
151	COVER
152	COVER
153	COVER
154	COVER
155	COVER
156	COVER
157	COVER
158	COVER
159	COVER
160	COVER
161	COVER
162	COVER
163	COVER
164	COVER
165	COVER
166	COVER
167	COVER
168	COVER
169	COVER
170	COVER
171	COVER
172	COVER
173	COVER
174	COVER
175	COVER
176	COVER
177	COVER
178	COVER
179	COVER
180	COVER
181	COVER
182	COVER
183	COVER
184	COVER
185	COVER
186	COVER
187	COVER
188	COVER
189	COVER
190	COVER
191	COVER
192	COVER
193	COVER
194	COVER
195	COVER
196	COVER
197	COVER
198	COVER
199	COVER
200	COVER



Engine Breakdown

Part No.
TM520-6500



NO.	NAME	QUANTITY
1	FRAMES	1
2	FRAMES	2
3	FRAMES	2
4	FRAMES	2
5	FRAMES	2
6	FRAMES	2
7	FRAMES	2
8	FRAMES	2
9	FRAMES	2
10	FRAMES	2
11	FRAMES	2
12	FRAMES	2
13	FRAMES	2
14	FRAMES	2
15	FRAMES	2
16	FRAMES	2
17	FRAMES	2
18	FRAMES	2
19	FRAMES	2
20	FRAMES	2
21	FRAMES	2
22	FRAMES	2
23	FRAMES	2
24	FRAMES	2
25	FRAMES	2
26	FRAMES	2
27	FRAMES	2
28	FRAMES	2
29	FRAMES	2
30	FRAMES	2
31	FRAMES	2
32	FRAMES	2
33	FRAMES	2
34	FRAMES	2
35	FRAMES	2
36	FRAMES	2
37	FRAMES	2
38	FRAMES	2
39	FRAMES	2
40	FRAMES	2
41	FRAMES	2
42	FRAMES	2
43	FRAMES	2
44	FRAMES	2
45	FRAMES	2
46	FRAMES	2
47	FRAMES	2
48	FRAMES	2
49	FRAMES	2
50	FRAMES	2
51	FRAMES	2
52	FRAMES	2
53	FRAMES	2
54	FRAMES	2
55	FRAMES	2
56	FRAMES	2
57	FRAMES	2
58	FRAMES	2
59	FRAMES	2
60	FRAMES	2
61	FRAMES	2
62	FRAMES	2
63	FRAMES	2
64	FRAMES	2
65	FRAMES	2
66	FRAMES	2
67	FRAMES	2
68	FRAMES	2
69	FRAMES	2
70	FRAMES	2
71	FRAMES	2
72	FRAMES	2
73	FRAMES	2
74	FRAMES	2
75	FRAMES	2
76	FRAMES	2
77	FRAMES	2
78	FRAMES	2
79	FRAMES	2
80	FRAMES	2
81	FRAMES	2
82	FRAMES	2
83	FRAMES	2
84	FRAMES	2
85	FRAMES	2
86	FRAMES	2
87	FRAMES	2
88	FRAMES	2
89	FRAMES	2
90	FRAMES	2
91	FRAMES	2
92	FRAMES	2
93	FRAMES	2
94	FRAMES	2
95	FRAMES	2
96	FRAMES	2
97	FRAMES	2
98	FRAMES	2
99	FRAMES	2
100	FRAMES	2

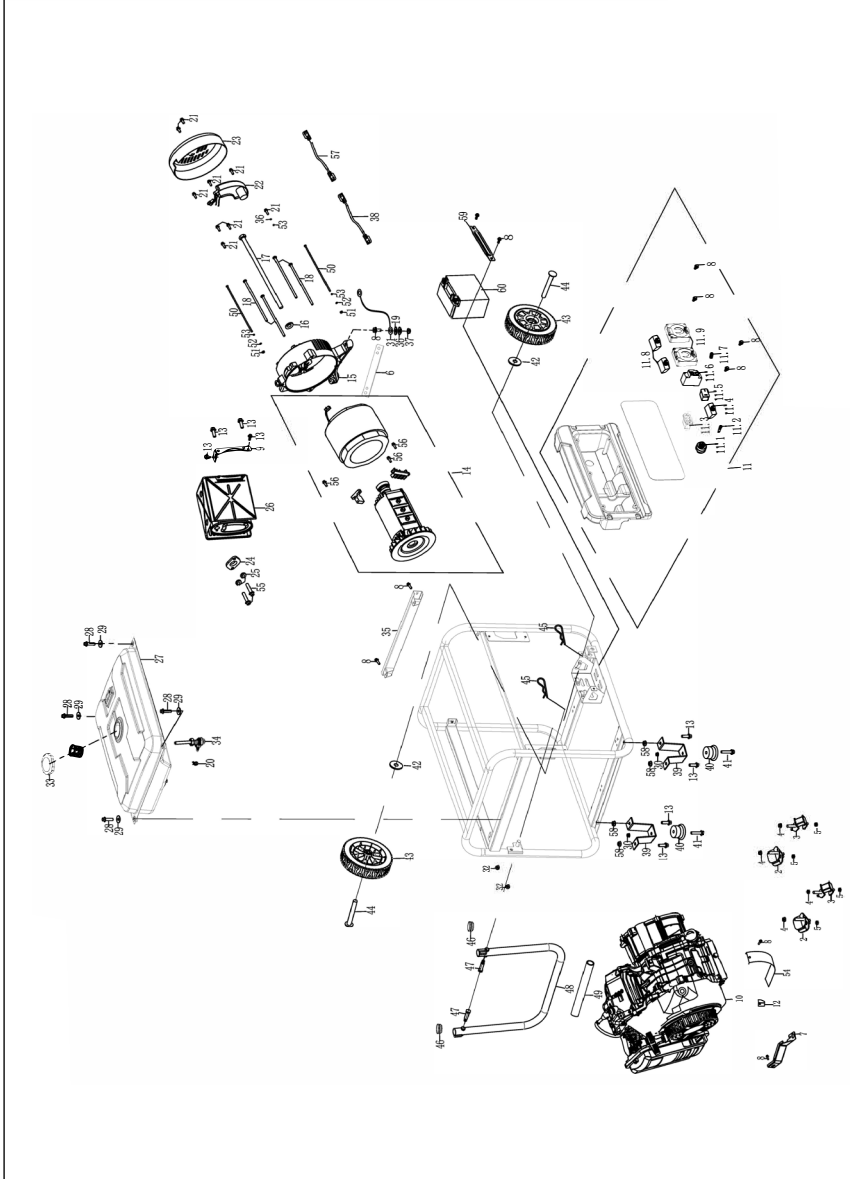

Generator Parts List

Part No.
TM520-6600



NO.	CODE	PART NAME	QUANTITY
1	000001	ENGINE CASE	1
2	000002	COVER	1
3	000003	STARTER MOTOR	1
4	000004	STARTER MOTOR MOUNTING BRACKET	2
5	000005	STARTER MOTOR DRIVE SHAFT	1
6	000006	STARTER MOTOR DRIVE GEAR	1
7	000007	STARTER MOTOR DRIVE GEAR HOUSING	1
8	000008	STARTER MOTOR DRIVE GEAR HOUSING COVER	1
9	000009	STARTER MOTOR DRIVE GEAR HOUSING COVER GASKET	1
10	000010	STARTER MOTOR DRIVE GEAR HOUSING COVER GASKET O-RING	1
11	000011	STARTER MOTOR DRIVE GEAR HOUSING COVER GASKET O-RING	1
12	000012	STARTER MOTOR DRIVE GEAR HOUSING COVER GASKET O-RING	1
13	000013	STARTER MOTOR DRIVE GEAR HOUSING COVER GASKET O-RING	1
14	000014	STARTER MOTOR DRIVE GEAR HOUSING COVER GASKET O-RING	1
15	000015	STARTER MOTOR DRIVE GEAR HOUSING COVER GASKET O-RING	1
16	000016	STARTER MOTOR DRIVE GEAR HOUSING COVER GASKET O-RING	1
17	000017	STARTER MOTOR DRIVE GEAR HOUSING COVER GASKET O-RING	1
18	000018	STARTER MOTOR DRIVE GEAR HOUSING COVER GASKET O-RING	1
19	000019	STARTER MOTOR DRIVE GEAR HOUSING COVER GASKET O-RING	1
20	000020	STARTER MOTOR DRIVE GEAR HOUSING COVER GASKET O-RING	1
21	000021	STARTER MOTOR DRIVE GEAR HOUSING COVER GASKET O-RING	1
22	000022	STARTER MOTOR DRIVE GEAR HOUSING COVER GASKET O-RING	1
23	000023	STARTER MOTOR DRIVE GEAR HOUSING COVER GASKET O-RING	1
24	000024	STARTER MOTOR DRIVE GEAR HOUSING COVER GASKET O-RING	1
25	000025	STARTER MOTOR DRIVE GEAR HOUSING COVER GASKET O-RING	1
26	000026	STARTER MOTOR DRIVE GEAR HOUSING COVER GASKET O-RING	1
27	000027	STARTER MOTOR DRIVE GEAR HOUSING COVER GASKET O-RING	1
28	000028	STARTER MOTOR DRIVE GEAR HOUSING COVER GASKET O-RING	1
29	000029	STARTER MOTOR DRIVE GEAR HOUSING COVER GASKET O-RING	1
30	000030	STARTER MOTOR DRIVE GEAR HOUSING COVER GASKET O-RING	1
31	000031	STARTER MOTOR DRIVE GEAR HOUSING COVER GASKET O-RING	1
32	000032	STARTER MOTOR DRIVE GEAR HOUSING COVER GASKET O-RING	1
33	000033	STARTER MOTOR DRIVE GEAR HOUSING COVER GASKET O-RING	1
34	000034	STARTER MOTOR DRIVE GEAR HOUSING COVER GASKET O-RING	1
35	000035	STARTER MOTOR DRIVE GEAR HOUSING COVER GASKET O-RING	1
36	000036	STARTER MOTOR DRIVE GEAR HOUSING COVER GASKET O-RING	1
37	000037	STARTER MOTOR DRIVE GEAR HOUSING COVER GASKET O-RING	1
38	000038	STARTER MOTOR DRIVE GEAR HOUSING COVER GASKET O-RING	1
39	000039	STARTER MOTOR DRIVE GEAR HOUSING COVER GASKET O-RING	1
40	000040	STARTER MOTOR DRIVE GEAR HOUSING COVER GASKET O-RING	1
41	000041	STARTER MOTOR DRIVE GEAR HOUSING COVER GASKET O-RING	1
42	000042	STARTER MOTOR DRIVE GEAR HOUSING COVER GASKET O-RING	1
43	000043	STARTER MOTOR DRIVE GEAR HOUSING COVER GASKET O-RING	1
44	000044	STARTER MOTOR DRIVE GEAR HOUSING COVER GASKET O-RING	1
45	000045	STARTER MOTOR DRIVE GEAR HOUSING COVER GASKET O-RING	1
46	000046	STARTER MOTOR DRIVE GEAR HOUSING COVER GASKET O-RING	1
47	000047	STARTER MOTOR DRIVE GEAR HOUSING COVER GASKET O-RING	1
48	000048	STARTER MOTOR DRIVE GEAR HOUSING COVER GASKET O-RING	1
49	000049	STARTER MOTOR DRIVE GEAR HOUSING COVER GASKET O-RING	1
50	000050	STARTER MOTOR DRIVE GEAR HOUSING COVER GASKET O-RING	1
51	000051	STARTER MOTOR DRIVE GEAR HOUSING COVER GASKET O-RING	1
52	000052	STARTER MOTOR DRIVE GEAR HOUSING COVER GASKET O-RING	1
53	000053	STARTER MOTOR DRIVE GEAR HOUSING COVER GASKET O-RING	1
54	000054	STARTER MOTOR DRIVE GEAR HOUSING COVER GASKET O-RING	1
55	000055	STARTER MOTOR DRIVE GEAR HOUSING COVER GASKET O-RING	1
56	000056	STARTER MOTOR DRIVE GEAR HOUSING COVER GASKET O-RING	1
57	000057	STARTER MOTOR DRIVE GEAR HOUSING COVER GASKET O-RING	1
58	000058	STARTER MOTOR DRIVE GEAR HOUSING COVER GASKET O-RING	1
59	000059	STARTER MOTOR DRIVE GEAR HOUSING COVER GASKET O-RING	1
60	000060	STARTER MOTOR DRIVE GEAR HOUSING COVER GASKET O-RING	1
61	000061	STARTER MOTOR DRIVE GEAR HOUSING COVER GASKET O-RING	1
62	000062	STARTER MOTOR DRIVE GEAR HOUSING COVER GASKET O-RING	1
63	000063	STARTER MOTOR DRIVE GEAR HOUSING COVER GASKET O-RING	1
64	000064	STARTER MOTOR DRIVE GEAR HOUSING COVER GASKET O-RING	1
65	000065	STARTER MOTOR DRIVE GEAR HOUSING COVER GASKET O-RING	1
66	000066	STARTER MOTOR DRIVE GEAR HOUSING COVER GASKET O-RING	1
67	000067	STARTER MOTOR DRIVE GEAR HOUSING COVER GASKET O-RING	1
68	000068	STARTER MOTOR DRIVE GEAR HOUSING COVER GASKET O-RING	1
69	000069	STARTER MOTOR DRIVE GEAR HOUSING COVER GASKET O-RING	1
70	000070	STARTER MOTOR DRIVE GEAR HOUSING COVER GASKET O-RING	1
71	000071	STARTER MOTOR DRIVE GEAR HOUSING COVER GASKET O-RING	1
72	000072	STARTER MOTOR DRIVE GEAR HOUSING COVER GASKET O-RING	1
73	000073	STARTER MOTOR DRIVE GEAR HOUSING COVER GASKET O-RING	1
74	000074	STARTER MOTOR DRIVE GEAR HOUSING COVER GASKET O-RING	1
75	000075	STARTER MOTOR DRIVE GEAR HOUSING COVER GASKET O-RING	1
76	000076	STARTER MOTOR DRIVE GEAR HOUSING COVER GASKET O-RING	1
77	000077	STARTER MOTOR DRIVE GEAR HOUSING COVER GASKET O-RING	1
78	000078	STARTER MOTOR DRIVE GEAR HOUSING COVER GASKET O-RING	1
79	000079	STARTER MOTOR DRIVE GEAR HOUSING COVER GASKET O-RING	1
80	000080	STARTER MOTOR DRIVE GEAR HOUSING COVER GASKET O-RING	1
81	000081	STARTER MOTOR DRIVE GEAR HOUSING COVER GASKET O-RING	1
82	000082	STARTER MOTOR DRIVE GEAR HOUSING COVER GASKET O-RING	1
83	000083	STARTER MOTOR DRIVE GEAR HOUSING COVER GASKET O-RING	1
84	000084	STARTER MOTOR DRIVE GEAR HOUSING COVER GASKET O-RING	1
85	000085	STARTER MOTOR DRIVE GEAR HOUSING COVER GASKET O-RING	1
86	000086	STARTER MOTOR DRIVE GEAR HOUSING COVER GASKET O-RING	1
87	000087	STARTER MOTOR DRIVE GEAR HOUSING COVER GASKET O-RING	1
88	000088	STARTER MOTOR DRIVE GEAR HOUSING COVER GASKET O-RING	1
89	000089	STARTER MOTOR DRIVE GEAR HOUSING COVER GASKET O-RING	1
90	000090	STARTER MOTOR DRIVE GEAR HOUSING COVER GASKET O-RING	1
91	000091	STARTER MOTOR DRIVE GEAR HOUSING COVER GASKET O-RING	1
92	000092	STARTER MOTOR DRIVE GEAR HOUSING COVER GASKET O-RING	1
93	000093	STARTER MOTOR DRIVE GEAR HOUSING COVER GASKET O-RING	1
94	000094	STARTER MOTOR DRIVE GEAR HOUSING COVER GASKET O-RING	1
95	000095	STARTER MOTOR DRIVE GEAR HOUSING COVER GASKET O-RING	1
96	000096	STARTER MOTOR DRIVE GEAR HOUSING COVER GASKET O-RING	1
97	000097	STARTER MOTOR DRIVE GEAR HOUSING COVER GASKET O-RING	1
98	000098	STARTER MOTOR DRIVE GEAR HOUSING COVER GASKET O-RING	1
99	000099	STARTER MOTOR DRIVE GEAR HOUSING COVER GASKET O-RING	1
100	000100	STARTER MOTOR DRIVE GEAR HOUSING COVER GASKET O-RING	1

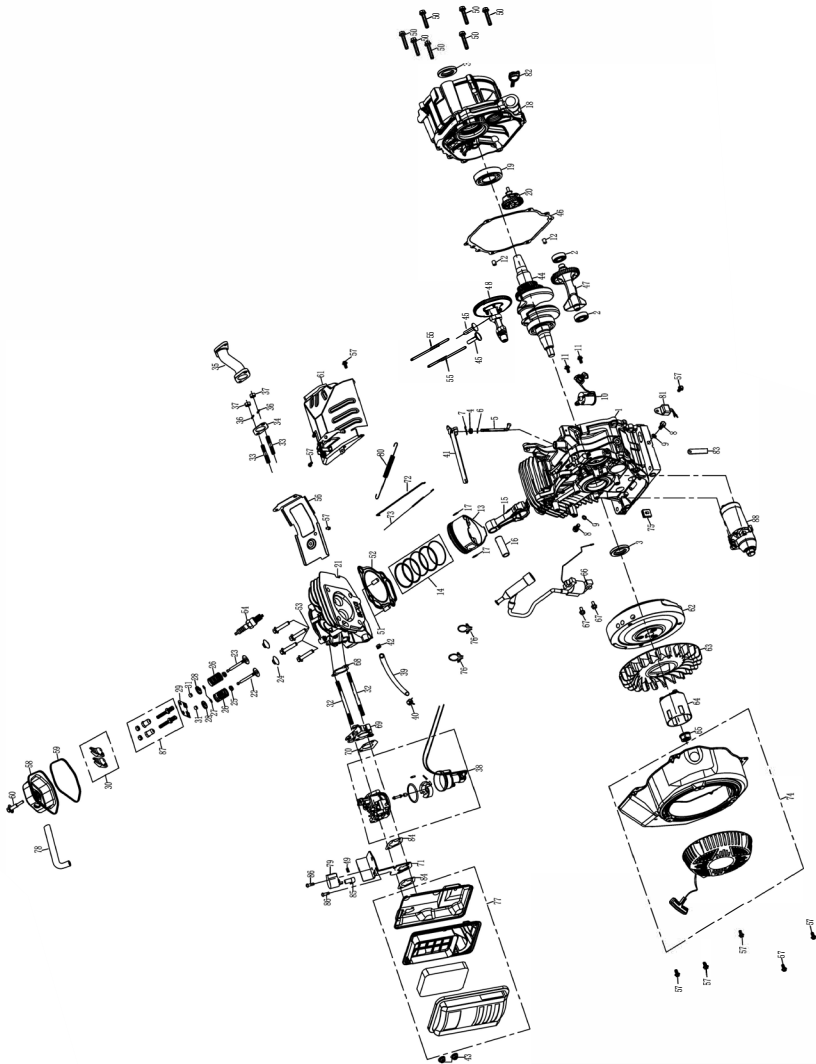

Engine Breakdown

Part No.
TM520-8000



563	1600000000	REAR WHEEL
564	1600000000	ISOLATED
565	1600000000	ISOLATED
566	1600000000	ISOLATED
567	1600000000	ISOLATED
568	1600000000	ISOLATED
569	1600000000	ISOLATED
570	1600000000	ISOLATED
571	1600000000	ISOLATED
572	1600000000	ISOLATED
573	1600000000	ISOLATED
574	1600000000	ISOLATED
575	1600000000	ISOLATED
576	1600000000	ISOLATED
577	1600000000	ISOLATED
578	1600000000	ISOLATED
579	1600000000	ISOLATED
580	1600000000	ISOLATED
581	1600000000	ISOLATED
582	1600000000	ISOLATED
583	1600000000	ISOLATED
584	1600000000	ISOLATED
585	1600000000	ISOLATED
586	1600000000	ISOLATED
587	1600000000	ISOLATED
588	1600000000	ISOLATED
589	1600000000	ISOLATED
590	1600000000	ISOLATED
591	1600000000	ISOLATED
592	1600000000	ISOLATED
593	1600000000	ISOLATED
594	1600000000	ISOLATED
595	1600000000	ISOLATED
596	1600000000	ISOLATED
597	1600000000	ISOLATED
598	1600000000	ISOLATED
599	1600000000	ISOLATED
600	1600000000	ISOLATED
601	1600000000	ISOLATED
602	1600000000	ISOLATED
603	1600000000	ISOLATED
604	1600000000	ISOLATED
605	1600000000	ISOLATED
606	1600000000	ISOLATED
607	1600000000	ISOLATED
608	1600000000	ISOLATED
609	1600000000	ISOLATED
610	1600000000	ISOLATED
611	1600000000	ISOLATED
612	1600000000	ISOLATED
613	1600000000	ISOLATED
614	1600000000	ISOLATED
615	1600000000	ISOLATED
616	1600000000	ISOLATED
617	1600000000	ISOLATED
618	1600000000	ISOLATED
619	1600000000	ISOLATED
620	1600000000	ISOLATED
621	1600000000	ISOLATED
622	1600000000	ISOLATED
623	1600000000	ISOLATED
624	1600000000	ISOLATED
625	1600000000	ISOLATED
626	1600000000	ISOLATED
627	1600000000	ISOLATED
628	1600000000	ISOLATED
629	1600000000	ISOLATED
630	1600000000	ISOLATED
631	1600000000	ISOLATED
632	1600000000	ISOLATED
633	1600000000	ISOLATED
634	1600000000	ISOLATED
635	1600000000	ISOLATED
636	1600000000	ISOLATED
637	1600000000	ISOLATED
638	1600000000	ISOLATED
639	1600000000	ISOLATED
640	1600000000	ISOLATED
641	1600000000	ISOLATED
642	1600000000	ISOLATED
643	1600000000	ISOLATED
644	1600000000	ISOLATED
645	1600000000	ISOLATED
646	1600000000	ISOLATED
647	1600000000	ISOLATED
648	1600000000	ISOLATED
649	1600000000	ISOLATED
650	1600000000	ISOLATED
651	1600000000	ISOLATED
652	1600000000	ISOLATED
653	1600000000	ISOLATED
654	1600000000	ISOLATED
655	1600000000	ISOLATED
656	1600000000	ISOLATED
657	1600000000	ISOLATED
658	1600000000	ISOLATED
659	1600000000	ISOLATED
660	1600000000	ISOLATED
661	1600000000	ISOLATED
662	1600000000	ISOLATED
663	1600000000	ISOLATED
664	1600000000	ISOLATED
665	1600000000	ISOLATED
666	1600000000	ISOLATED
667	1600000000	ISOLATED
668	1600000000	ISOLATED
669	1600000000	ISOLATED
670	1600000000	ISOLATED
671	1600000000	ISOLATED
672	1600000000	ISOLATED
673	1600000000	ISOLATED
674	1600000000	ISOLATED
675	1600000000	ISOLATED
676	1600000000	ISOLATED
677	1600000000	ISOLATED
678	1600000000	ISOLATED
679	1600000000	ISOLATED
680	1600000000	ISOLATED
681	1600000000	ISOLATED
682	1600000000	ISOLATED
683	1600000000	ISOLATED
684	1600000000	ISOLATED
685	1600000000	ISOLATED
686	1600000000	ISOLATED
687	1600000000	ISOLATED
688	1600000000	ISOLATED
689	1600000000	ISOLATED
690	1600000000	ISOLATED
691	1600000000	ISOLATED
692	1600000000	ISOLATED
693	1600000000	ISOLATED
694	1600000000	ISOLATED
695	1600000000	ISOLATED
696	1600000000	ISOLATED
697	1600000000	ISOLATED
698	1600000000	ISOLATED
699	1600000000	ISOLATED
700	1600000000	ISOLATED

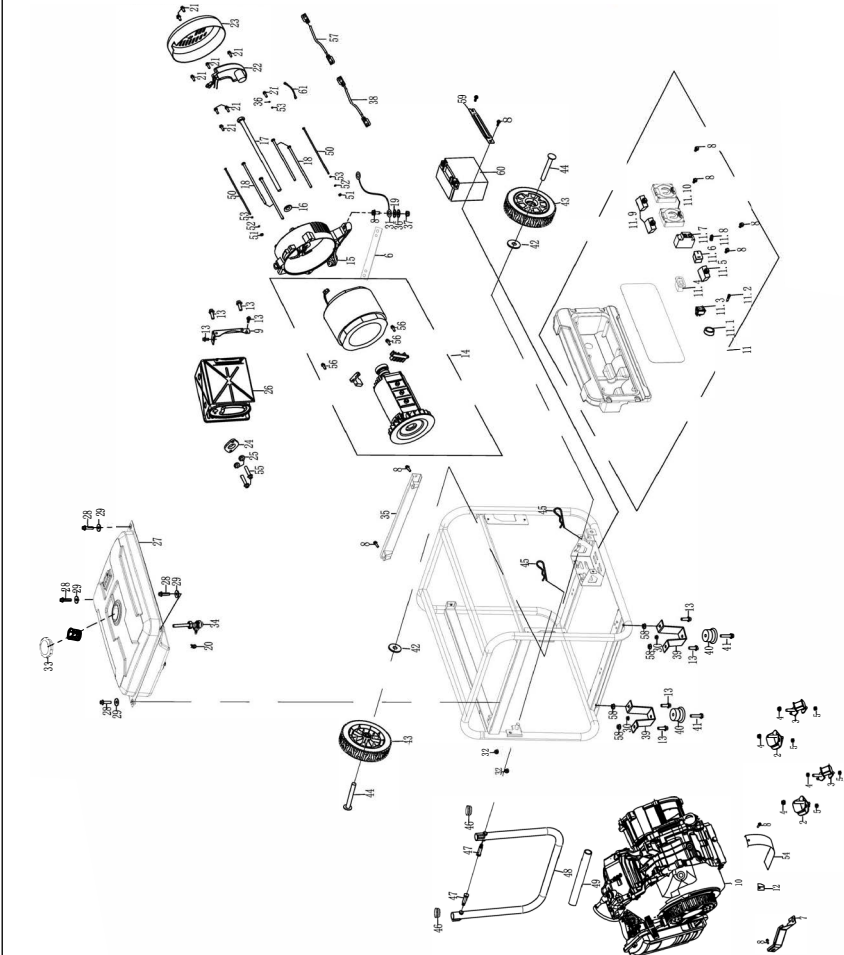

Generator Parts List

Part No.
TM520-8000



CONTROL PANEL

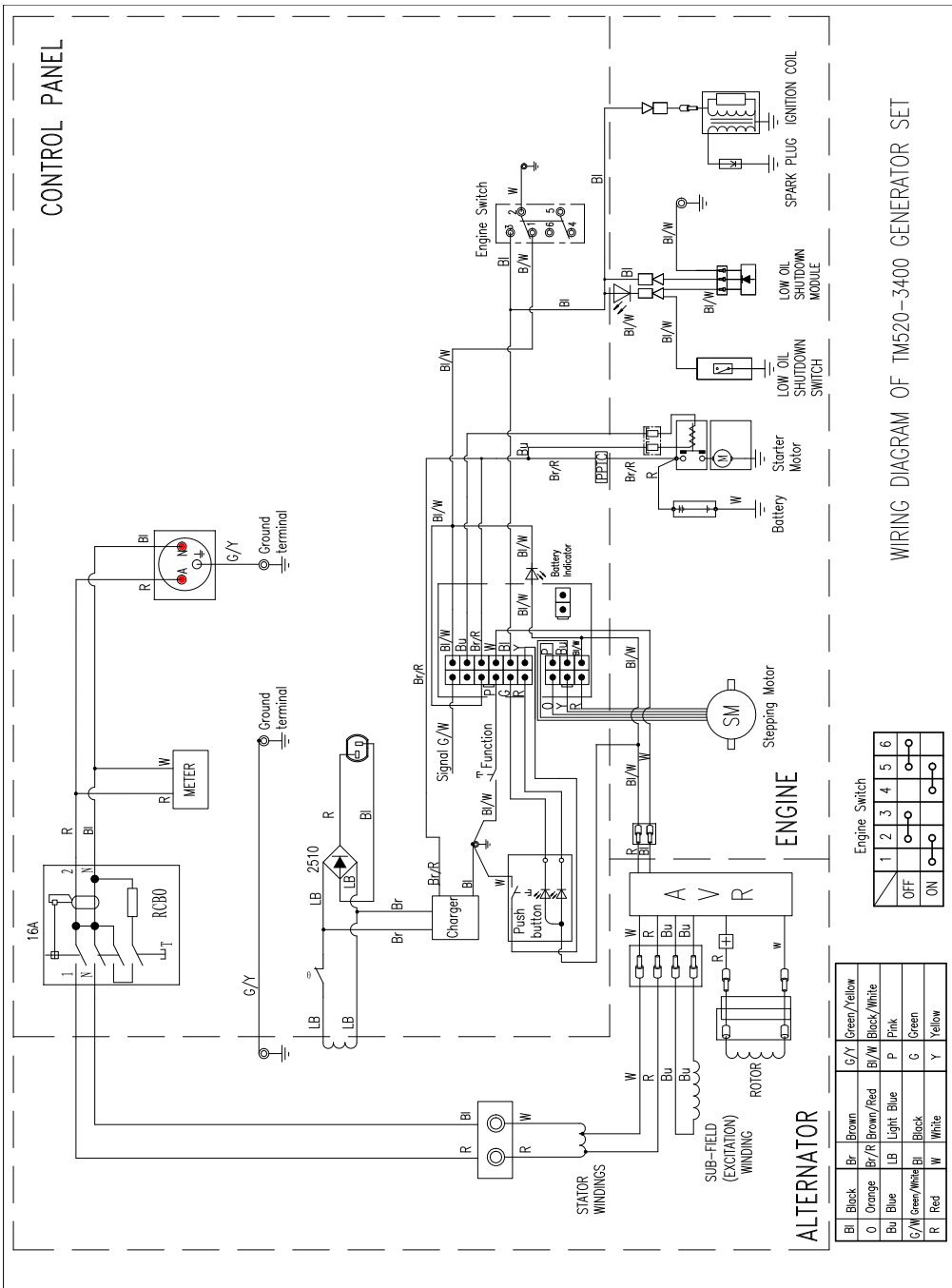

WIRING DIAGRAM OF TM520-3400 GENERATOR SET

Bl	Black	G/Y	Green/Yellow
Br	Brown	B/W	Black/White
Or	Orange	P	Pink
Bl	Blue	C	Green
G/W	Green/White	Y	Yellow
R	Red		

Engine Switch	1	2	3	4	5	6
OFF	○	○	○	○	○	○
ON	○	○	○	○	○	○

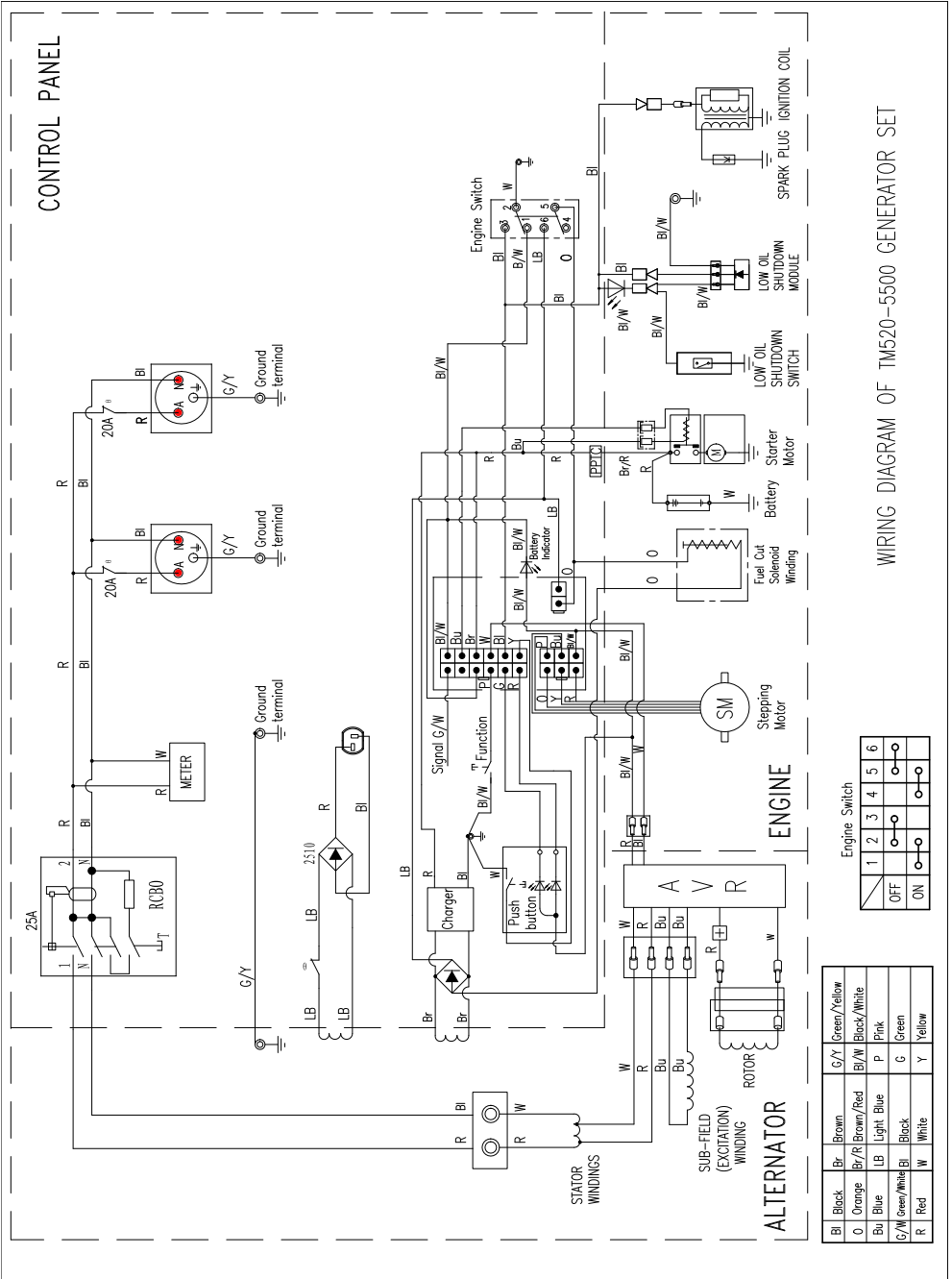

WIRING DIAGRAM OF TM520-6500 GENERATOR SET

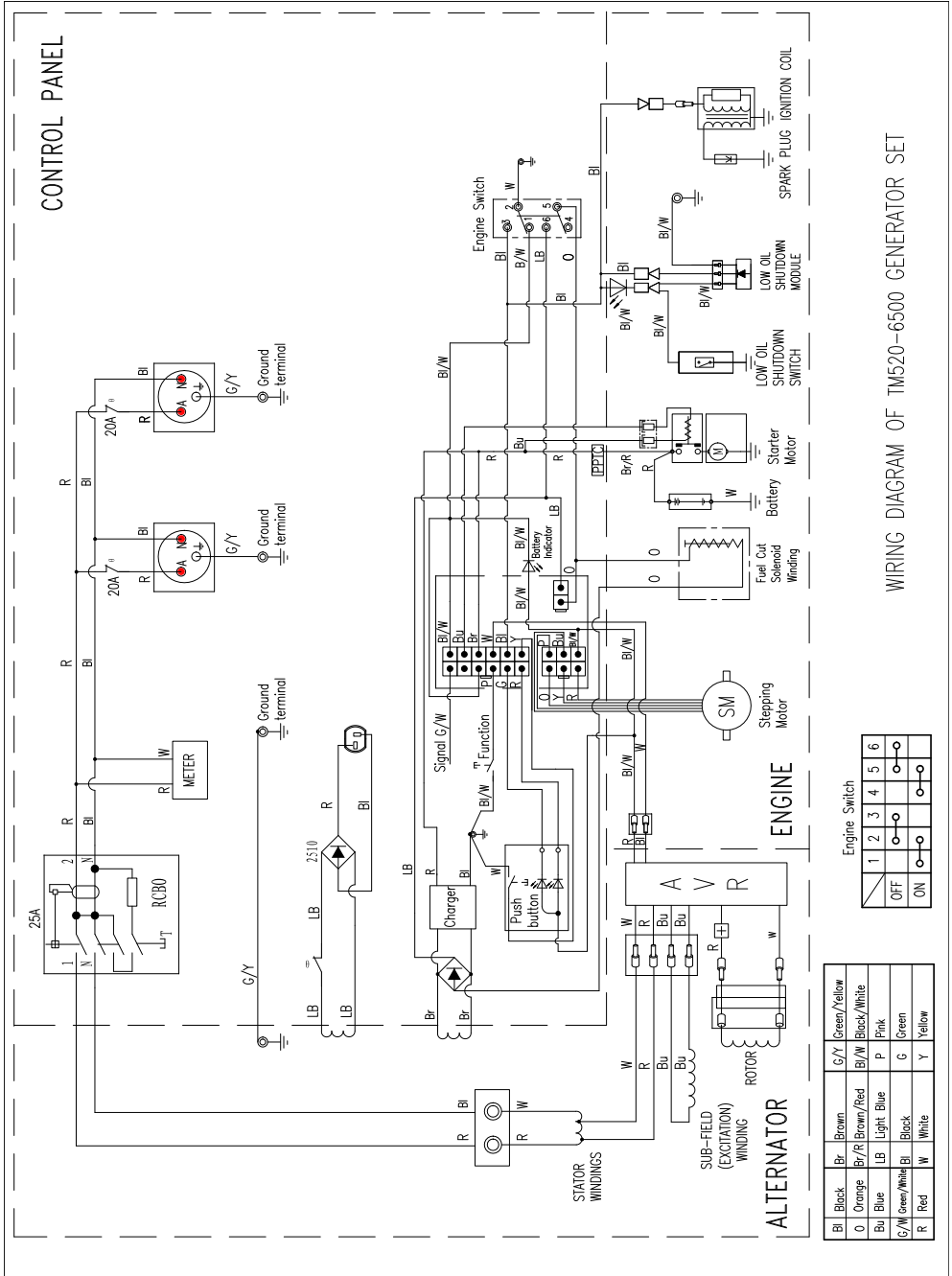

Bl	Black	Br	Brown	C/Y	Green/Yellow
O	Orange	Br/R	Brown/Red	Bl/W	Black/White
Bu	Blue	LB	Light Blue	P	Pink
G/W	Green/White	Bl	Black	G	Green
R	Red	W	White	Y	Yellow

	1	2	3	4	5	6
OFF	<input type="radio"/>	<input type="radio"/>	<input type="radio"/>	<input type="radio"/>	<input type="radio"/>	<input type="radio"/>
ON	<input type="radio"/>	<input type="radio"/>	<input type="radio"/>	<input type="radio"/>	<input type="radio"/>	<input type="radio"/>

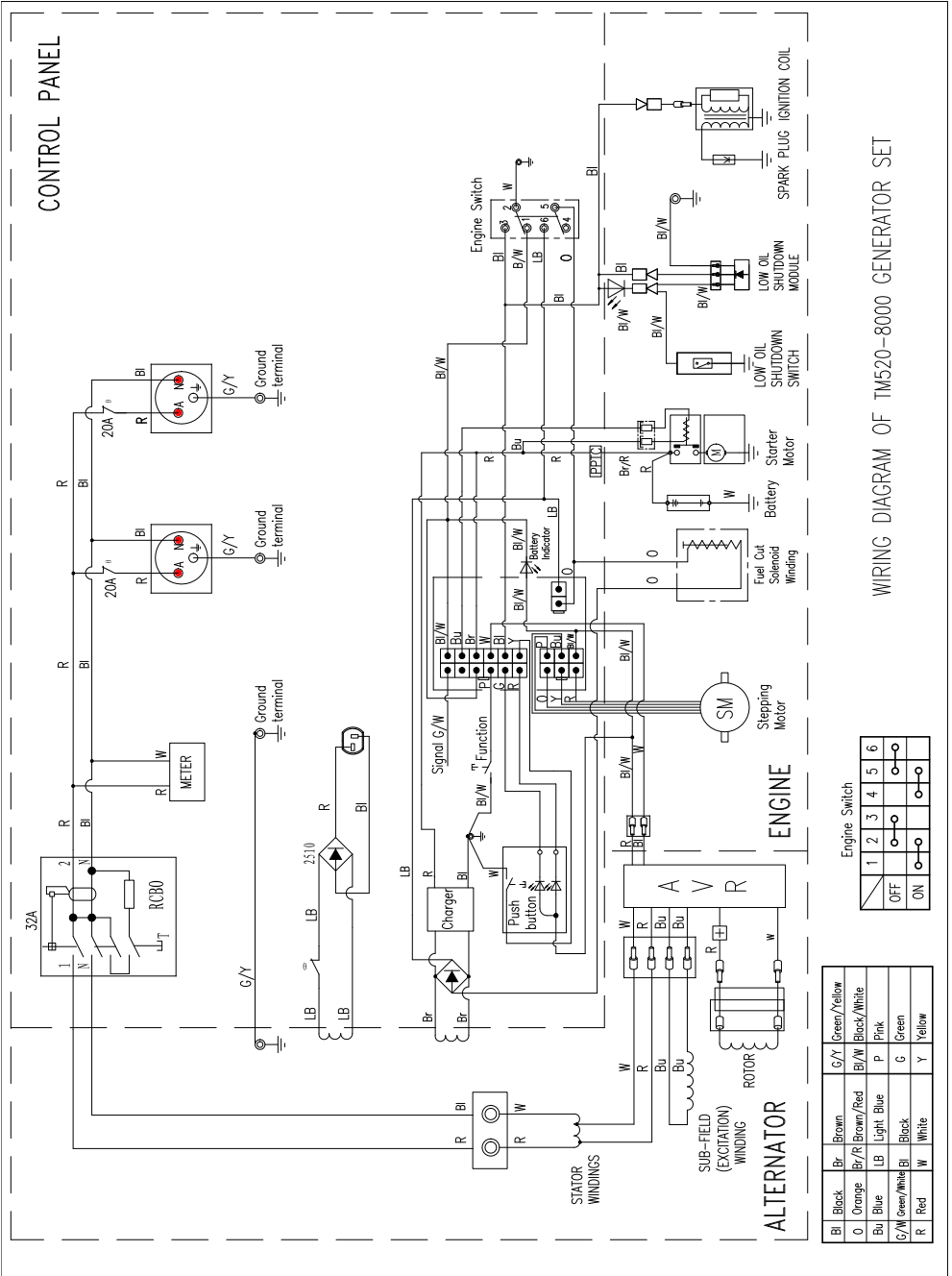

Bl Black	Br	Brown	G/Y	Green/Yellow
O Orange	Br/R	Brown/Red	B/W	Black/White
Bu Blue	LB	Light Blue	P	Pink
G/W	Green/White	Black	G	Green
R Red	W	White	Y	Yellow

	1	2	3	4	5	6
OFF	<input type="checkbox"/>	<input type="checkbox"/>	<input type="checkbox"/>	<input type="checkbox"/>	<input type="checkbox"/>	<input type="checkbox"/>
ON	<input type="checkbox"/>	<input type="checkbox"/>	<input type="checkbox"/>	<input type="checkbox"/>	<input type="checkbox"/>	<input type="checkbox"/>