



INDUSTRIAL SERIES
AIR COMPRESSOR

2.5_{HP}

BELT DRIVE AIR COMPRESSOR

OPERATOR'S MANUAL

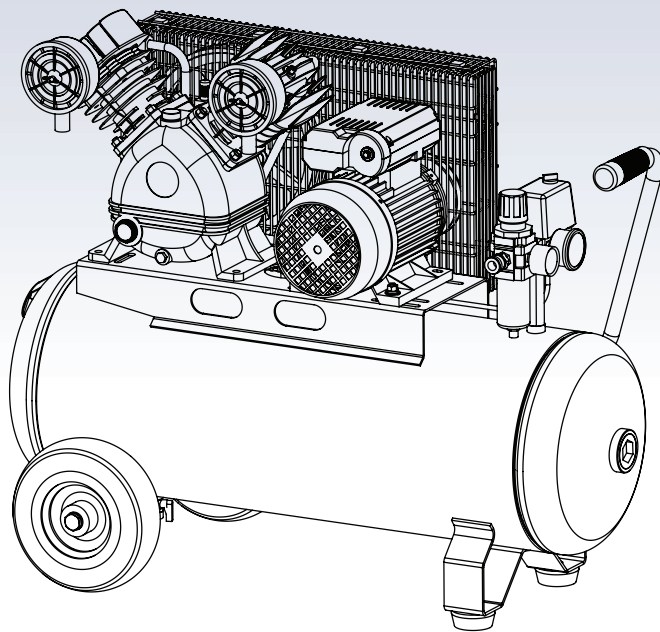

TM351-25060 (60Ltr Tank)

TM351-25090 (90Ltr Tank)

Ver: 1.0

TABLE OF CONTENTS

| | |
|------------------------------------|----|
| Warranty | 2 |
| Product Specifications | 3 |
| Product Diagram & Parts List | 4 |
| Safety Instructions | 7 |
| Getting Started | 9 |
| Maintenance | 10 |
| Trouble Shooting | 10 |

LIMITED WARRANTY

Industrial Tool & Machinery Sales (hereinafter referred to as ITMS) will, within twelve (12) months from the original date of purchase, repair or replace any goods found to be defective in materials or workmanship.

This warranty is void if the item has been damaged by accident, neglect, improper service or other causes not arising out of defects in materials or workmanship. This warranty does not apply to machines and/or components which have been altered, changed, or modified in any way, or subjected to overloading or use beyond recommended capacities and specifications. Worn componentry due to normal wear and tear is not a warranty claim. Goods returned defective shall be returned prepaid freight to ITMS or agreed repair agent, which shall be the buyer's sole and exclusive remedy for defective goods. ITMS accepts no additional liability pursuant to this guarantee for the costs of travelling or transportation of the product or parts to and from ITMS or the service agent or dealer, such costs are not included in this warranty.

Our goods come with guarantees which cannot be excluded under the Australian Consumer Law. You are entitled to replacement or refund for a major failure and to compensation for other reasonably foreseeable loss or damage. You are also entitled to have the goods repaired or replaced if the goods fail to be of acceptable quality and the failure does not amount to a major failure.

THE MANUFACTURER RESERVES THE RIGHT TO MAKE IMPROVEMENTS AND MODIFICATIONS TO DESIGN WITHOUT PRIOR NOTICE.

PRODUCTS IMPORTED AND DISTRIBUTED NATIONALLY BY:



INDUSTRIAL TOOL & MACHINERY SALES
18 BUSINESS ST, YATALA QLD 4207
T: 07 3287 1114 E: sales@industrialtool.com.au
F: 07 3287 1115 W: www.itmtools.com.au

! SAFETY INFORMATION

Please read and understand this entire manual before attempting to operate the product. Improper operation or maintenance of this product could result in serious injury and property damage. Read and understand all warnings and operation instructions before using this equipment. When using air tools, basic safety precautions should always be followed to reduce the risk of personal injury.

ITM air compressors are manufactured to AS1210 Standards.
This air receiver is registered with WorkSafe Australia to comply with plant registration regulations in Australia.

PRODUCT SPECIFICATIONS

| COMPONENT | SPECIFICATIONS | |
|-------------------|------------------|------------------|
| Model | TM351-25060 | TM351-25090 |
| Motor | 2.5HP / 1.86KW | 2.5HP / 1.86KW |
| Rated Speed | 2,850 RPM | 2,850 RPM |
| Voltage | 240V / 50 Hz | 240V / 50 Hz |
| Tank Capacity | 60 Litre | 90 Litre |
| Max Pressure | 145 psi (10 Bar) | 145 psi (10 Bar) |
| Free Air Delivery | 257 Ltr/min | 257 Ltr/min |
| Circuit Required | 10 Amp | 10 Amp |
| Pump Type | Belt Drive | Belt Drive |

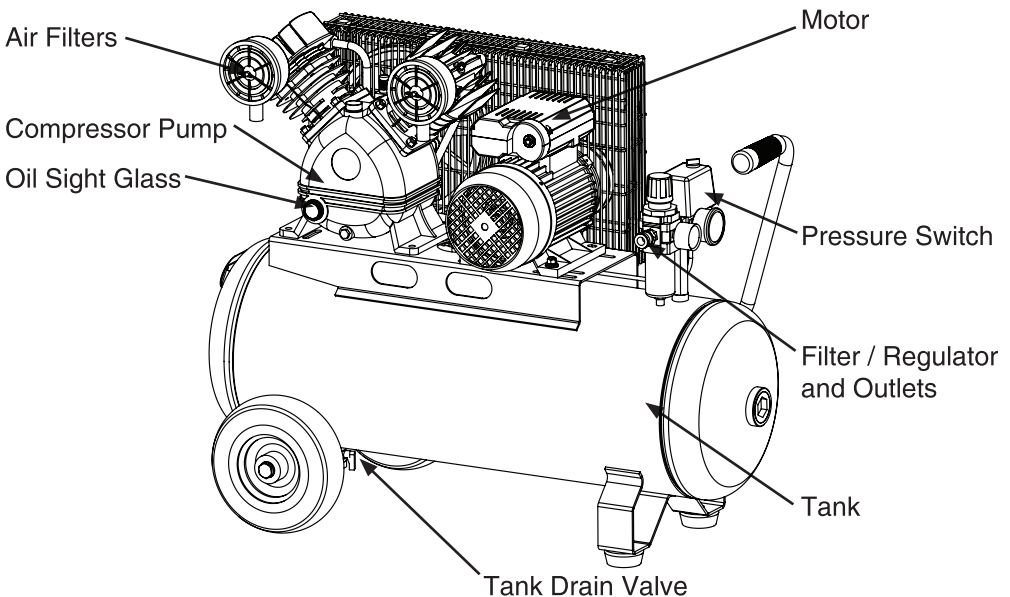

PARTS DIAGRAM - MAIN ASSEMBLY

TM351-25060 Model

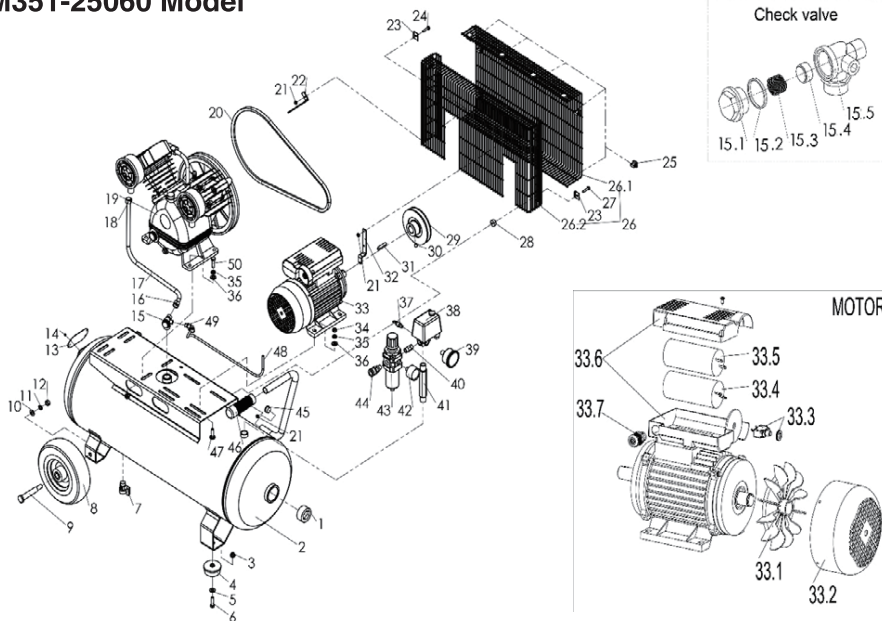

PARTS LIST

| No. | Qty. | Part Name | No. | Qty. | Part Name | No. | Qty. | Part Name |
|------|------|-------------------|------|------|--------------------|------|------|--------------------------|
| 1 | 2 | Plug, Socket head | 17 | 1 | Copper tube | 33.4 | 1 | Capacitance,45uf/450VAC |
| 2 | 1 | Air Tank | 18 | 1 | Sleeve nut | 33.5 | 1 | Capacitance,150uf/350VAC |
| 3 | 6 | Hex. Nut | 19 | 1 | Pump | 33.6 | 1 | Capacitance box |
| 4 | 2 | Rubber foot | 20 | 1 | V-Belt | 33.7 | 1 | Cable clamp |
| 5 | 2 | PL. Washer | 21 | 4 | Hex. Nut | 34 | 4 | Hex. Nut |
| 6 | 2 | Hex. Bolt | 22 | 1 | Bracket | 35 | 8 | Sp. Washer |
| 7 | 1 | Ball valve | 23 | 4 | Steel clip | 36 | 8 | PL. Washer |
| 8 | 2 | wheel | 24 | 2 | Hex. Bolt | 37 | 1 | Safety valve |
| 9 | 2 | Axle | 25 | 7 | Plastic clip | 38 | 1 | Pressure switch |
| 10 | 2 | PL. Washer | 26 | 1 | Belt guard | 39 | 1 | Pressure gauge |
| 11 | 2 | SP. Washer | 26.1 | 1 | Belt guard (FR) | 40 | 1 | Nipple |
| 12 | 2 | Hex. Nut | 26.2 | 1 | Belt guard (RR) | 41 | 1 | Nipple |
| 13 | 1 | Tank name plate | 27 | 2 | Hex. Bolt | 42 | 1 | Pressure Gauge |
| 14 | 4 | rivet | 28 | 2 | Rubble washer | 43 | 1 | Pressure Regulator |
| 15 | 1 | Check Valve | 29 | 1 | Motor pulley | 44 | 1 | Quick Coupler, Mato |
| 15.1 | 1 | Bonnet | 30 | 1 | Set screw | 45 | 1 | Grip, Handle |
| 15.2 | 1 | O-ring | 31 | 1 | Key | 46 | 1 | Grip, Handle |
| 15.3 | 1 | Spring | 32 | 1 | Guard bracket | 47 | 4 | Bolt |
| 15.4 | 1 | valve element | 33 | 1 | Motor | 48 | 1 | Discharge Tube |
| 15.5 | 1 | valve body | 33.1 | 1 | Fan | 49 | 1 | Elbow fitting |
| 16 | 1 | Sleeve nut | 33.2 | 1 | Fan cover | 50 | 2 | Hex. Bolt |
| | | | 33.3 | 1 | Overload protector | 50 | 4 | Hex. Bolt |

PARTS DIAGRAM - MAIN ASSEMBLY

TM351-25090 Model

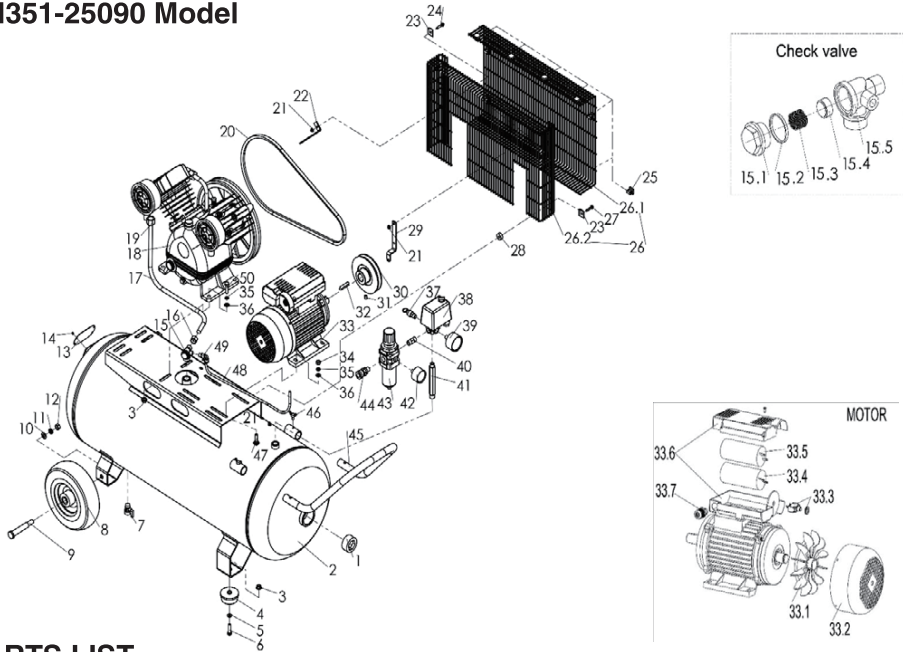

PARTS LIST

| No. | Qty. | Part Name | No. | Qty. | Part Name | No. | Qty. | Part Name |
|------|------|-------------------|------|------|-----------------|------|------|---------------------------|
| 1 | 2 | Plug, Socket head | 17 | 1 | Copper tube | 33.3 | 1 | Overload protector |
| 2 | 1 | Air Tank | 18 | 1 | Pump | 33.4 | 1 | Capacitance, 45uf/450VAC |
| 3 | 6 | Hex. Nut | 19 | 1 | Sleeve nut | 33.5 | 1 | Capacitance, 150uf/350VAC |
| 4 | 2 | Rubber foot | 20 | 1 | V-Belt | 33.6 | 1 | Capacitance box |
| 5 | 2 | PL. Washer | 21 | 4 | Hex. Nut | 33.7 | 1 | Cable clamp |
| 6 | 2 | Hex. Bolt | 22 | 1 | Bracket | 34 | 4 | Hex. Nut |
| 7 | 1 | Ball valve | 23 | 4 | Steel clip | 35 | 8 | Sp. Washer |
| 8 | 2 | wheel | 24 | 2 | Hex. Bolt | 36 | 8 | PL. Washer |
| 9 | 2 | Axle | 25 | 7 | Plastic clip | 37 | 1 | Safety valve |
| 10 | 2 | PL. Washer | 26 | 1 | Belt guard | 38 | 1 | Pressure switch |
| 11 | 2 | SP. Washer | 26.1 | 1 | Belt guard (FR) | 39 | 1 | Pressure gauge |
| 12 | 2 | Hex. Nut | 26.2 | 1 | Belt guard (RR) | 40 | 1 | Nipple |
| 13 | 1 | Tank name plate | 27 | 2 | Hex. Bolt | 41 | 1 | Nipple |
| 14 | 4 | rivet | 28 | 2 | Rubble washer | 42 | 1 | Pressure Gauge |
| 15 | 1 | Check Valve | 29 | 1 | Motor pulley | 43 | 1 | Pressure Regulator |
| 15.1 | 1 | Bonnet | 30 | 1 | Set screw | 44 | 1 | Quick Coupler, Mato |
| 15.2 | 1 | O-ring | 31 | 1 | Key | 45 | 1 | Handle |
| 15.3 | 1 | Spring | 32 | 1 | Guard bracket | 46 | 2 | Butterfly bolt |
| 15.4 | 1 | valve element | 33 | 1 | Motor | 47 | 4 | Bolt |
| 15.5 | 1 | valve body | 33.1 | 1 | Fan | 48 | 1 | Discharge Tube |
| 16 | 1 | Sleeve nut | 33.2 | 1 | Fan cover | 49 | 1 | Elbow fitting |
| | | | | | | 50 | 2 | Hex. Bolt |

PARTS DIAGRAM - PUMP

Both Models

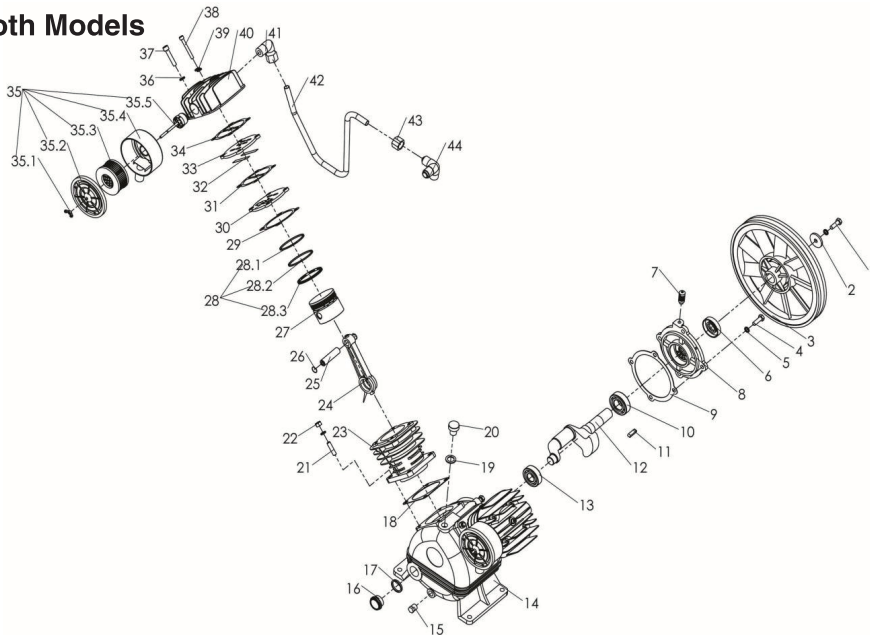

PARTS LIST

| | | |
|-----------------------|---------------------------|--------------------------|
| 1 Hex.Bolt | 21 Stud Bolt | 35.3 Element |
| 2 PL.Washer | 22 Hex.Nut | 35.4 Case |
| 3 Flywheel | 23 Cylinder | 35.5 Screw |
| 4 Hex.Bolt | 24 connecting rod | 36 SP.washer |
| 5 Sp.Washer | 25 Piston pin | 37 Hex.socket screw |
| 6 Oil seal | 26 Circlip | 38 Hex.socket screw |
| 7 Breather | 27 Piston | 39 SP.washer |
| 8 Front Cover | 28 Piston ring Kit | 40 Cylinder head |
| 9 Gasket, Front Cover | 28.1 Compression Ring | 41 Elbow fitting |
| 10 Bearing 6204 | 28.2 Scraping Ring | 42 Copper tube |
| 11 Key | 28.3 Oil Ring | 43 Sleeve nut |
| 12 Crankshaft | 29 Gasket, Valve | 44 3-way manifold nipple |
| 13 Bearing 6205 | 30 Valve Seat1 | |
| 14 Crankcase | 31 Gasket, Valve blade | |
| 15 Plug | 32 Blade, Valve | |
| 16 Sealing | 33 Valve seat2 | |
| 17 Oil sight glass | 34 Gasket, Cylinder cover | |
| 18 Cylinder gasket | 35 Air filter Ass'y | |
| 19 O ring | 35.1 Butterfly.Nut | |
| 20 Oil cap | 35.2 Case | |

GENERAL SAFETY RULES FOR OPERATION

Before attempting to operate this compressor the following basic safety precautions should always be taken to reduce the risk of fire and personal injury. It is important to read the instruction manual to understand the application, limitations and potential hazards associated with any tool. They are designed for the safety of yourself and others, ensuring a long and trouble free service life from your machine.

Work Area

- a. Keep work area clean and well lit. Cluttered and dark areas invite accidents.
- b. Floors should be kept clean and free from rubbish. Special care should be taken if the floor is slippery due to sawdust or wax.
- c. Keep children and bystanders away while operating a compressor. Distractions can cause you to lose control.
- d. Do not use compressor in areas where there is a risk of explosion or fire from combustible materials, flammable liquids, e.g., paint, varnish, petrol etc or flammable gases and dust of an explosive nature.

Electrical Safety

- a. Power tool plugs must match the outlet. Never modify the plug in any way. Do not use any adapter plugs with earthed (grounded) power tools. Unmodified plugs and matching outlets will reduce risk of electric shock.
- b. Do not expose the compressor to rain or wet conditions. Water entering the electric motor will increase the risk of electric shock.
- c. Do not abuse the cord. Never use the cord for pulling or unplugging the compressor. Keep cord away from heat, oil, sharp edges or moving parts. Damaged or entangled cords increase the risk of electric shock.

Personal Safety

- a. Stay alert, watch what you are doing and use common sense when operating a compressor. Do not use while you are tired or under the influence of drugs, alcohol or medication. A moment of inattention while operating this compressor may result in serious personal injury.
- b. Use safety equipment. Always wear eye protection. Safety equipment such as dust mask, non-skid safety shoes or hearing protection used for appropriate conditions will reduce personal injuries.
- c. Avoid accidental starting. Ensure the switch is in the off-position before plugging in.
- d. Do not overreach. Keep proper footing and balance at all times. This enables better control of the power tool in unexpected situations.
- e. Dress properly. Do not wear loose clothing or jewellery. Keep your hair, clothing and gloves away from moving parts. Loose clothes, jewellery or long hair can be caught in moving parts.

GENERAL SAFETY RULES FOR OPERATION

General

- a. Do not operate the compressor without the belt guard being correctly fitted.
- b. Do not attempt to modify the compressor in any way.
- c. The use of any tool or accessory other than those designed for use with compressed air could result in injury to the operator.
- d. The output pressure of the compressor should be adjusted to the design pressure of the air tool or accessory being used.
- e. Always check that the output of the compressor does not exceed the maximum pressure for any attached tool or accessory.
- f. Repairs should only be carried out by qualified persons using original spare parts. Failure to do so may result in considerable danger to the user.

Breathable Air Warning

This compressor/pump is not equipped and should not be used to supply breathing quality air for any application of air for human consumption.

Check Damaged Parts

Before using the compressor it should be carefully checked to determine that it will operate properly and perform its intended function. Check for the correct alignment of moving parts ensuring they do not bind. Check for broken or missing parts and have them replaced or repaired at an authorised service centre. Check any other condition that may affect the operation of the compressor. A guard or any other part of the compressor that is damaged should be properly repaired or replaced by an authorised service centre.

Disconnect Compressor

Ensure that the compressor is disconnected from the mains supply and the tank is empty when not in use, before servicing, lubricating or making adjustments to air lines when changing accessories such as blades, bits, nails and cutters on air tools.

Avoid Unintentional Starting

Ensure that the switch is in the OFF position before plugging the compressor into the mains supply.

Turning The Compressor ON And OFF

Only turn the compressor on and off by using the knob on top of the pressure switch, do not leave it on and switch the compressor on or off from the power supply. Turning the unit on and off from the mains supply only will result in damage to the motor and void warranty as the pressure switch has an additional function to purge the air trapped in the delivery pipe when the motor is turned off. This minimises the load on the motor when it is next started.

GETTING STARTED

Assembly

This air compressor requires some minor assemble before it can be used.

Locate the accessory pack/s. These should contain :

1. Wheel/s and axle set.
2. Rubber stoppers.
3. Air filters.
4. Oil filler breather.

Position the unit on a even surface:

1. Fit the wheel/s to the unit.
2. Fit the rubber stoppers to the legs of the unit.
3. Remove the plastic transit plugs from the cylinder heads and screw in the plastic air filters.
4. Remove the plastic transit plugs from the pump oil filler hole and screw in the oil filler breather.

Oil Warning : Check the oil level before using the compressor.

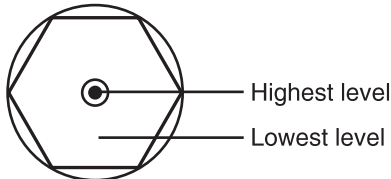

Check the oil level. If necessary add oil until it reaches the red mark on the sight glass. Do Not over fill.

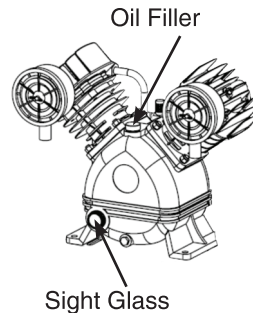

NOTE: The oil must be changed after the first 10 hours of operation then every 50 hours thereafter. Recommended compressor oil:

| | | | |
|-------|---------------------|---------|--------------|
| AGIP | DICREA100 | MOBIL | RARUS 427 |
| BP | ENERGOL CS100 | FINA | EOLAN AC 100 |
| SHELL | COREMA OIL H10 | CASTROL | AIRCOL PD100 |
| ESSO | EXXC OLUB 150 | TOTAL | CORTUSA 100 |
| FUCHX | RENOLIN 104L VG 100 | API | CM-8X |
| IP | CALATIA OIL ISO 100 | | |

(Suitable for room temperature ranging from +5°C to +25°C)



WARNING

Ensure the compressor is disconnected from the power supply when performing maintenance tasks to avoid injury.

| MAINTENANCE REQUIRED | FREQUENCY |
|--|-----------------|
| Check pump oil level | Before each use |
| Drain the condensation from the air tank | Before each use |
| Check for loose nuts / bolts and tighten | Before each use |
| Check for air leaks | Before each use |
| Remove air filter and clean (or replace as required) | Weekly |
| Check belt tension | Weekly |
| Change pump oil | Every 6 Months |
| Tighten cylinder head bolts | Every 6 Months |
| Clean and check non return valve | Every 6 Months |

TROUBLE SHOOTING

| TROUBLE | POSSIBLE CAUSES | REMEDIES |
|---|--|---|
| Motor unable to run or running slow | <ul style="list-style-type: none"> Fault in line, or voltage insufficient Power wire too thin or too long Fault in pressure switch Fault in motor Sticking of main compressor | <ul style="list-style-type: none"> Check the line Replace the wire Repair or replace Repair or replace Check and repair |
| Sticking of main compressor | <ul style="list-style-type: none"> Moving parts burnt due to the oil insufficient Moving parts damaged, or stuck by foreign body | Check crankshaft, bearing, connecting rod, piston, piston ring, etc. and replace if necessary |
| Excessive vibration or abnormal Noise | <ul style="list-style-type: none"> Connecting part loose Foreign body got into main compressor Piston knocking valve seat Moving parts seriously worn | <ul style="list-style-type: none"> Check and retighten Check and clean away Replace with thicker paper gasket Repair or replace |
| Pressure insufficient or discharge capacity decreased | <ul style="list-style-type: none"> Motor running too slow Air filter choked up Leakage of safety valve Leakage of discharge pipe Sealing gasket damaged Valve plate damaged, carbon buildup or stuck Piston ring and cylinder worn or damaged | <ul style="list-style-type: none"> Check and remedy Clean or replace the cartridge Check and adjust Check and repair Check and replace Replace and clean Repair or replace |
| Excessive oil consumption | <ul style="list-style-type: none"> Oil level too high Breath pipe choked up Piston ring and cylinder worn or damaged | <ul style="list-style-type: none"> Keep the level within set range Check and clean Repair or replace |