



SAFETY INSTRUCTIONS

WARNING:

To avoid mistakes that could cause injury, do not use the Multitool until you have read and understood the following:

- ALWAYS WEAR EYE PROTECTION.** A full-face visor is preferred. Any Belt/Disc Grinder can throw foreign objects into the eyes
- AVOID CONTACT** with Belt or Disc. The abrasive belt when running is an aggressive cutting tool. Extra care should be exercised when using coarse grit belts because of their rapid cutting action.
- KEEP CHILDREN AWAY.** All visitors should be kept a safe distance from the work area.
- BOLT THE BENCH GRINDER** securely to the bench or supporting surface to stop it from tipping over or moving when in use.
- DO NOT MOUNT** the attachment protruding into walkways.
- KEEP WORK AREA CLEAN.** Cluttered areas and benches invite accidents.
- ALWAYS WEAR A DUST MASK** to prevent dust inhalation when adequate ventilation or extraction is not available.
- DO NOT WEAR LOOSE CLOTHING**, which may become entangled in the machine. Wear protective hair covering to contain long hair.
- ALWAYS HOLD** the work piece firmly when grinding and apply a light and steady pressure against abrasive disc or belt.
- ALWAYS GRIND ON THE DOWNWARD SIDE** of the grinding disc. Grinding on the upward side of the disc could cause the work piece to fly out of position, resulting in injury.
- DO NOT USE** belts that are damaged, torn or show signs of wear.
- ALWAYS INSTALL BELTS** with arrows in the back of the belts facing the correct direction. Belts and lap joints must be fitted facing the correct direction. See sketch below.

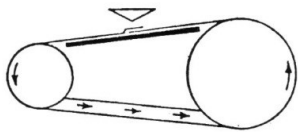

INTRODUCTION TO BELT GRINDING

Belt grinding or finishing has many advantages over the use of conventional grinding wheels. It is possible to remove material up to 5 times faster than the equivalent grade of grinding wheel with far less heat. The electrostatic process used in the manufacture of an abrasive belt ensures that the sharp side of each piece of grit is facing outwards on the belt thus giving cleaner, smoother and faster cutting. The flexing of the belt has a self cleaning action and also it does not overheat, making it more suitable to any application where heat could damage the work, for example, grinding leather, plastics, tool sharpening etc

BELT APPLICATIONS

ALL METALS	COARSE FINISH	Use 40 to 80 Grit aluminium Oxide Belts
Grit	MEDIUM TO FINE	Use 100 to 80 Grit
	VERY FINE	Use 250 to 400 Grit
	MICROFINISHING	Use 3M Trizact 600 to 2000
ALUMINIUM	HEAVY GRINDING OR THIN SECTIONS	Use Zirconia Belts 40,60,80
	Always use belt grease to prevent clogging.	
WOOD	Use Aluminium Oxide Resin Bond open or close. 40, 60, 80, 100, 120	
PLASTICS & GLASS CERAMIC	Use Silicon Carbide Resin Bond 40 to 600 Grit 7.5	

AVAILABLE ACCESSORIES

- MITRE TABLE – an adjustable angle work table for Disc Grinding
- SHARPENING JIG – for sharpening chisels to 2" (51mm) plane blades to 2 3/8" (60mm) power planer blades to 3 1/4" (82mm) and re-tipping screwdrivers with professional results. Fits all Multitool Models except the 8CW.
- BELT GREASE – to prevent clogging on aluminium and other soft metals.
- BELT CLEANING STICK – removes wood or grease build up – prolongs belt life.
- POLISHING COMPOUND – for use with type T Belts.
- TILT STAND AND TABLE – Tilting grinder base to 90° & Tool rest for belt grinder.

OPERATING INSTRUCTIONS

BELT CHANGING

To remove the belt simply push down on the underside of belt to compress the tensioner assembly. The Catch automatically holds slide in retracted position. When refitting the belt simply release the Catch (Fig 3: O). Always make sure belt lap faces the correct direction. (see diagram left).

BELT TRACKING

Always ensure the belt entirely covers the rubber contact wheel. Adjustment is made when running or when belt is rotated by hand. To adjust left, move tracking lever down. To adjust right, move lever up. If tracking lever is constantly set in up or down position refer to (Figs 5 & 6: N) of fitting instructions on reverse side.

PLATEN GRINDING (HORIZONTAL OR VERTICAL)

It is important that the Platen (Fig 4: P) is not set too high. If belt is deflected and rides up over the platen it creates an undue strain on the grinder, especially when starting. If the platen is not often used it is better to set a little clear of the belt. A simple method to adjust the platen is to place a straight edge on top of the belt, between the contact wheel and the drive pulley and raise platen so that it just touches under side of the belt. Work of any length can be surfaced on the platen, for example the sawn edges of wood from short pieces up to lengths of several metres. Never grind or sand on platen unless you are sure belt lap is facing in correct position. See diagram left).

DISC GRINDING

Whenever possible remove the belt when using the disc facility. The disc grinding facility is a very useful and versatile part of the attachment. It is very useful for dressing small castings and components, patterns, models etc. often eliminating costly machining. Tool and cutter sharpening is a simple task and there is less chance of burning edges. With the addition of the Mitre Table, lengths and angles are easy to adjust. Dressing end grain flat and square has always been a difficult task but now it is a simple and quick operation, making perfect joints possible. A rubber cleaning stick should be used regularly to prevent a build-up of wood resin. Three options are available in abrasive discs. 1. Self-Adhesive. 2. Fur backed – which must be used with an optional hook and loop backing pad. 3. Plain paper or cloth backed disc which must be attached with a contact adhesive. When changing a disc pad remove any remaining adhesive with a solvent, e.g. Lacquer thinner, acetone (nail polish remover). Do not use household cleaners.

CONTACT WHEEL GRINDING, POLISHING AND SANDING

Using the front contact wheel avails the user of material removal many times faster than a conventional grinding wheel. The unique smooth cutting action is cooler, faster and safer than conventional grinding methods. A good example of one of the many uses is the smoothing of welds and casting blemishes prior to plating. Using the extremely fast and easy belt change it is possible to go from a rough weld finish to a flat, smooth polish suitable to chrome plate in only two belt changes. e.g. Remove rough weld with 40, 60 or 80 grit belt. Remove grinding marks – 240 grit belt. Change ground finish to smooth, brushed finish for plating – Scotchbrite super fine. Wood shaping and finishing can be done in a similar manner but belts should always be kept exclusively for wood, especially in the finer grades. A rubber belt cleaning stick helps prevent clogging on wood use.

FREE STRAPPING

Free strapping is a method of belt grinding, sanding or polishing where no backing is used behind the belt. It is especially suitable for round and contoured work and some sharpening operations. It is done on the underneath side of the belt opposite the platen. Belt grades of 180 to 400 are recommended because of the rapid cutting action.

SPECIFICATIONS

MULTITOOL 362

Belt size 36" x 2" (915 x 50) Disc size 7" (178) Contact Wheel 3 1/2" (89) dia. Suits most 6" (150) or 8" (200) bench grinders with minimum 1/2 H.P. (248W) and Shaft sizes of 1/2" & 5/8" RATING Continuous Industrial.

MULTITOOL 482 & MULTITOOL 8CW

Belt size 48" x 2" (1220 x 50) Disc size 7" (178) Contact Wheel 3 1/2" (89) dia. 8CW Model. Suited to 8" (200) bench grinders with minimum 1/2 H.P. (373W) and Shaft size of 5/8"

MULTITOOL 364

BELT SIZE 36" x 4" (915 x 100) Disc size 7" (178) Contact Wheel 3 1/2" (89) dia. Suits most 6" (150) or 8" (200) bench grinders with minimum 1/2 H.P. (248W) and Shaft sizes of 1/2" & 5/8"

MULTITOOL 484

BELT SIZE 48" x 4" (1220 x 100) Disc size 7" (178) Contact Wheel 3 1/2" (89) dia. Suits most 8" (200) bench grinders with a minimum of 1/2" H.P. (248W) and Shaft size of 5/8"

BELT SPEED – ALL MODELS

AUSTRALIA	4200 Ft/min (1280 metres/min)
USA	5000 Ft/min (1524 metres/min)

WARRANTY AND CONDITIONS OF SALE

The words "us", "we" or "our" refers to P.A Products or their authorized agent.

- All Multitool products come with 1 year warranty from the date of original purchase. Warranty will only apply if the fitting and operating instructions are followed.
- The 1 year warranty applies to any defect caused by faulty materials or if the product does not perform to the manufacturers specifications. PA Products will repair, or at our option, replace the defective product or parts of the product. We will not be liable for any damage or malfunction caused by the user or any third party as a result of misuse or negligence. Unauthorised repair (or attempted repair) will void the warranty, whether or not damage has been caused by the repair/attempt.

INSTRUCTIONS TO FOLLOW FOR WARRANTY CLAIMS:

- If a warranty claim is made, we must be notified as soon as possible after the assumed defect has become apparent.
- Goods may only be returned for credit with the approval of PA Products in Australia Ph. +61-2-6331-8881 email: lynhoward2@bigpond.com
- The customer must prepay all freight charges for returned goods.
- The customer will be contacted after inspecting the goods, to determine what action should be taken in the circumstances.

Tech Support: Australia: PA Products +61-2-6331-8881 USA: H&B Distributors +1-714-521-3020

www.multitoolaustralia.com

PLEASE SAVE THESE INSTRUCTIONS

FITTING INSTRUCTIONS — ALL MULTITOOL MODELS

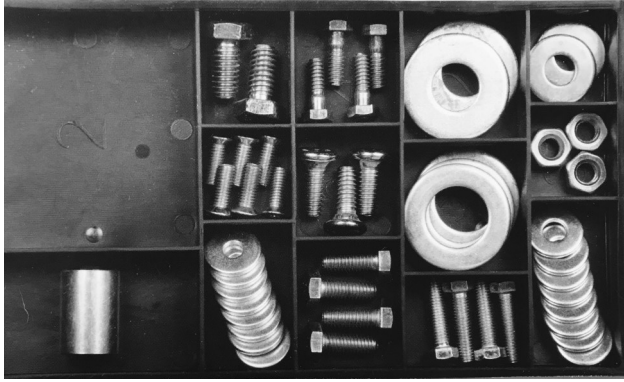

The Fitting Kit (pictured above) is provided with all Multitool models. Please refer to this image for all numbered items throughout the instructions

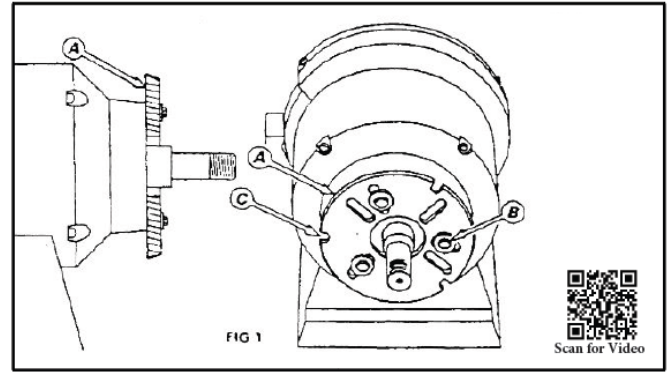

From the right hand end of the grinder, remove wheel cover, wheel, wheel flanges and wheel guard. Fit slotted adaptor plate (A) using either 6mm bolt (3), 5mm Bolt (5) or 4.8mm Bolt (9) from fitting kit. Use appropriate size washers under heads (1 or 12). **The outer edge of the adaptor plate is tapered. Face smallest side of taper away from grinder as shown in Fig 1. (A)**

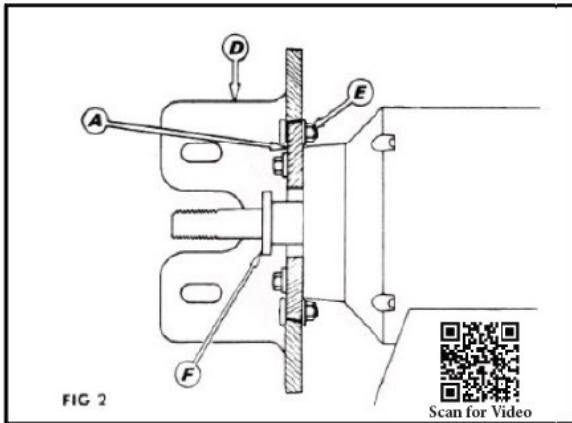

Fit the Main Bracket (D) using bolt (8) through the 3 slots (Fig 1: C) in outer edge of the adaptor plate, with the heads of bolts facing the grinder. With angle face of bracket approximately vertical, tighten 6mm nuts (6) evenly. The adaptor plate should be flush with the main bracket. If the Multitool is to be used in a vertical position simply loosen nuts, tap main bracket (D) to loosen. Swivel to desired position and retighten nuts (6). The above cutaway view is from the rear of the right hand end of the grinder showing the tapered fit of the adaptor plate (A) and main bracket (D).

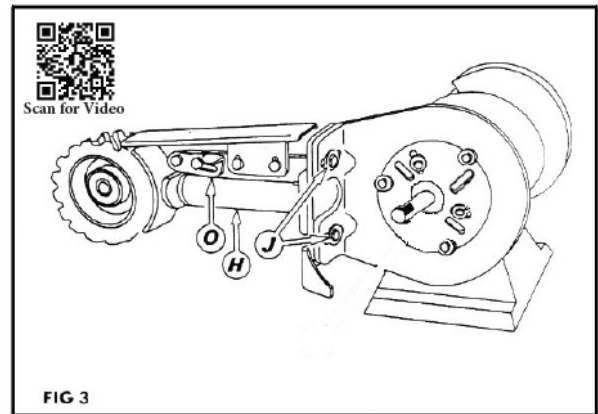

Fit the idler arm (H) using 8mm diameter bolts (2) and washers (7) provided. Fit one of the washers (13) for 1/2" / 12.7mm shafts or (11) for 3/8" / 15.9mm shafts and check that it clears heads of bolts (Fig 1: B). If there is interference, add the required amount of washers to gain acceptable clearance. The drive pulley (Fig 4: K) comes with a 15.9mm bore, there is a 12.7mm steel bush (10) provided for smaller shafts.

NOTE: The 4" (100mm) Drive Pulley in Multitool models 364 & 484 can be bored to a maximum of 25mm.

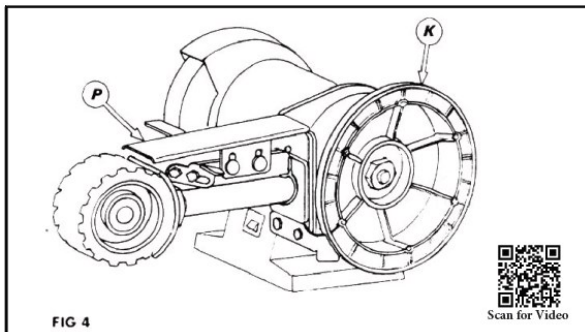

Fit the Drive Pulley (K) by sliding over the shaft of the grinder. Fit tightly against the washer(s) Use 12.7mm (13) or 15.9mm (11) diameter washer (Fig 3. F) under the nut and tighten with a socket spanner.

NOTE: A poor quality nut on the grinders spindle may prevent the pulley from running true. If this is the case replace the nut.

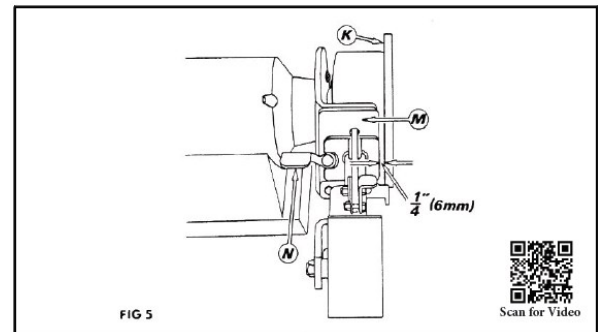

Idler arm Cam plate (M) must now be set 6mm clear of inside edge of the drive pulley (Fig 4. K) Slots are provided under 8mm bolts (Fig 3. J) for this adjustment.

Set tracking lever (N) in mid or horizontal position. Fit the belt and release spring loaded contact wheel by lifting the catch (Fig 3. O)

NOTE: It is not necessary to remove the platen as in Figs 5 & 6. This has been removed for clarity and instruction only.

N.B Once assembled there will always be some parts left in the fitting kit.

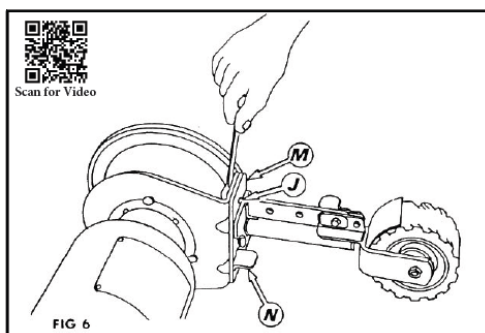

Pull the belt over a few revolutions by hand, if the belt wanders towards the drive pulley (K), loosen the top bolt (J) and tap the top of the cam plate (M) in small amount towards the drive pulley. If the belt moves towards the grinder, tap the top of cam plate (M) towards the grinder. When the belt runs evenly on the contact wheel, re-tighten bolt (J), turn grinder on to check. Final tracking adjustments can be done with the tracking lever (Fig 5. N). Pulling the tracking lever down moves belt to the left, up moves the belt to the right. Fit the cover disc using bolts (4). Clean face of cover disc with a solvent and fit the adhesive backed abrasive disc provided.