

Multitool

INTERNATIONAL

200MM HEAVY DUTY BENCH GRINDER

OPERATOR'S MANUAL

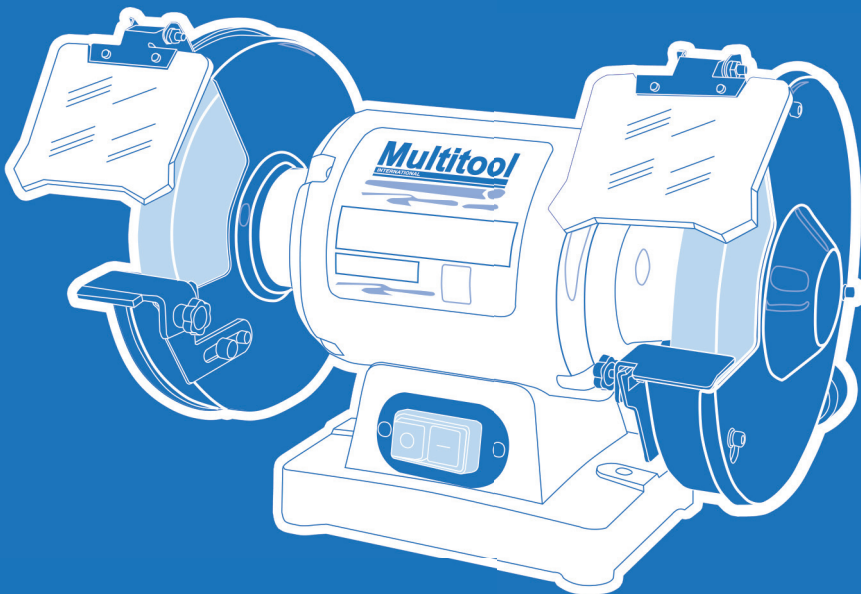

PO200HD

VER: 1.1

www.itmtools.com.au

TABLE OF CONTENTS

Warranty.....	2
Safety Information	3
Parts Diagram.....	4
Parts List.....	5
Safety Rules	6
Wheel Dressing	8
Cleaning	8
Getting Started	9
Troubleshooting.....	10

LIMITED WARRANTY

Industrial Tool & Machinery Sales (hereinafter referred to as ITMS) will, within 3 years from the original date of purchase, repair or replace any goods found to be defective in materials or workmanship.

This warranty is void if the item has been damaged by accident, neglect, improper service or other causes not arising out of defects in materials or workmanship. This warranty does not apply to machines and/or components which have been altered, changed, or modified in any way, or subjected to overloading or use beyond recommended capacities and specifications. Worn componentry due to normal wear and tear is not a warranty claim. Goods returned defective shall be returned prepaid freight to ITMS or agreed repair agent, which shall be the buyer's sole and exclusive remedy for defective goods. ITMS accepts no additional liability pursuant to this guarantee for the costs of travelling or transportation of the product or parts to and from ITMS or the service agent or dealer, such costs are not included in this warranty.

Our goods come with guarantees which cannot be excluded under the Australian Consumer Law. You are entitled to replacement or refund for a major failure and to compensation for other reasonably foreseeable loss or damage. You are also entitled to have the goods repaired or replaced if the goods fail to be of acceptable quality and the failure does not amount to a major failure.

THE MANUFACTURER RESERVES THE RIGHT TO MAKE IMPROVEMENTS AND MODIFICATIONS TO DESIGN WITHOUT PRIOR NOTICE.

PRODUCTS IMPORTED AND DISTRIBUTED NATIONALLY BY:



INDUSTRIAL TOOL & MACHINERY SALES

11 EASTERN SERVICE ROAD, STAPYLTON, QLD, 4207

T: 07 3287 1114 E: sales@industrialtool.com.au

F: 07 3287 1115 W: www.itmtools.com.au

SAFETY INFORMATION

Please read and understand this entire manual before attempting to operate the product.

⚠WARNING

Improper operation or maintenance of this product could result in serious injury and property damage. Read and understand all warnings and operation instructions before using this equipment. When using air tools, basic safety precautions should always be followed to reduce the risk of personal injury.

PRODUCT SPECIFICATIONS

COMPONENT	SPECIFICATIONS
Voltage	240V AC
Motor power	750 Watts (1 HP)
No load speed	2,950 rpm
Spindle thread	5/8" UNC
Wheel size	250 x 25mm
Grinding wheels	36# (coarse) and 60# (medium)

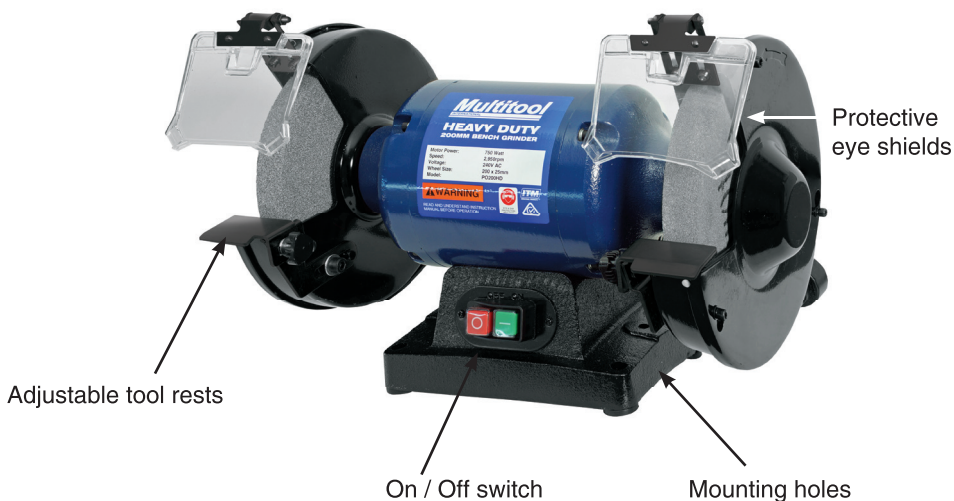

PARTS DIAGRAM

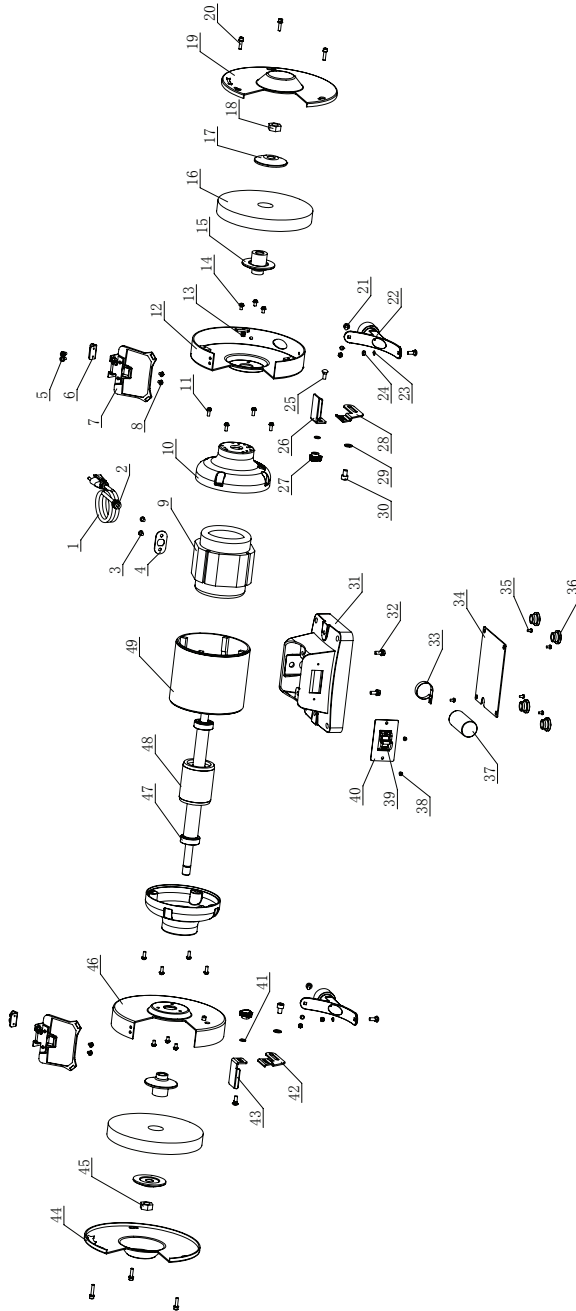

PARTS LIST

No.	NAME	Qty.
1	Cable & plug	1
2	Line pressing card	1
3	Screw	1
4	Outlet plate	1
5	Three combination of screws	4
6	Connecting bracket	2
7	Mirror protector assembly	2
8	Three combination of screws	4
9	Stator	1
10	Cover	2
11	Three combination of screws	8
12	Inner shield (R)	1
13	Locknut	6
14	Three combination of screws	6
15	Internal chuck	2
16	Grinding wheel	2
17	External chuck	2
18	Nut	1
19	Guard cover (R)	1
20	Inner hexagonal triple combination	6
21	Square-neck screws	4
22	Ash discharge drum	2
23	Spring washer	4
24	Nut	4
25	Square-neck screws	2
26	Workbench (R)	1
27	Handle nut	2
28	Support frame (R)	1
29	Flat washer	2
30	Inner hexagonal screw	2
31	Cast iron base	1
32	Outer hexagonal triple combination	2
33	Capacitance clamp	1
34	Plate	1
35	Two combination of screws	4
36	Foot	4
37	Capacitor	1
38	Screw	2
39	Key switch	1
40	Switch palte	1
41	Spring washer	2
42	Support frame (L)	1
43	Workbench (L)	1
44	Guard cover (L)	1
45	Nut	1
46	Inner shield (L)	1
47	Bearing	2
48	Rotor	1
49	Motor cylinder	1

GENERAL SAFETY RULES FOR OPERATION

WARNING! Read all instructions. Failure to follow all instructions listed below may result in electric shock, fire and/or serious injury. The term "power tool" in all of the warnings listed below refers to your mains-operated (corded) power tool or battery-operated (cordless) power tool.

SAVE THESE INSTRUCTIONS

Work Area

- a. Keep work area clean and well lit. Cluttered and dark areas invite accidents.
- b. Do not operate power tools in explosive atmospheres, such as in the presence of flammable liquids, gases or dust. Power tools create sparks which may ignite the dust or fumes.
- c. Keep children and bystanders away while operating a power tool. Distractions can cause you to lose control.

Electrical Safety

- a. Power tool plugs must match the outlet. Never modify the plug in any way. Do not use any adapter plugs with earthed (grounded) power tools. Unmodified plugs and matching outlets will reduce risk of electric shock.
- b. Avoid body contact with earthed or grounded surfaces such as pipes, radiators, ranges and refrigerators. There is an increased risk of electric shock if your body is earthed or grounded.
- c. Do not expose power tools to rain or wet conditions. Water entering a power tool will increase the risk of electric shock.
- d. Do not abuse the cord. Never use the cord for carrying, pulling or unplugging the power tool. Keep cord away from heat, oil, sharp edges or moving parts. Damaged or entangled cords increase the risk of electric shock.
- e. When operating a power tool outdoors, use an extension cord suitable for outdoor use. Use of a cord suitable for outdoor use reduces the risk of electric shock.

Personal Safety

- a. Stay alert, watch what you are doing and use common sense when operating a power tool. Do not use a power tool while you are tired or under the influence of drugs, alcohol or medication. A moment of inattention while operating power tools may result in serious personal injury.
- b. Use safety equipment. Always wear eye protection. Safety equipment such as dust mask, non-skid safety shoes, hard hat, or hearing protection used for appropriate conditions will reduce personal injuries.
- c. Avoid accidental starting. Ensure the switch is in the off-position before plugging in. Carrying power tools with your finger on the switch or plugging in power tools that have the switch on invites accidents.
- d. Remove any adjusting key or wrench before turning the power tool on. A wrench or a key left attached to a rotating part of the power tool may result in personal injury.
- e. Do not overreach. Keep proper footing and balance at all times. This enables better control of the power tool in unexpected situations.
- f. Dress properly. Do not wear loose clothing or jewellery. Keep your hair, clothing and gloves away from moving parts. Loose clothes, jewellery or long hair can be caught in moving parts.

Power tool use and care

- a. Do not force the power tool. Use the correct power tool for your application. The correct power tool will do the job better and safer at the rate for which it was designed.
- b. Do not use the power tool if the switch does not turn it on and off. Any power tool that cannot be controlled with the switch is dangerous and must be repaired.
- c. Disconnect the plug from the power source before making any adjustments, changing accessories, or storing power tools. Such preventive safety measures reduce the risk of starting the power tool accidentally.
- d. Store idle power tools out of the reach of children and do not allow persons unfamiliar with the power tool or these instructions to operate the power tool. Power tools are dangerous in the hands of untrained users.
- e. Maintain power tools. Check for misalignment or binding of moving parts, breakage of parts and any other condition that may affect the power tools operation. If damaged, have the power tool repaired before use. Many accidents are caused by poorly maintained power tools.
- f. Keep cutting tools sharp and clean. Properly maintained cutting tools with sharp cutting edges are less likely to bind and are easier to control.
- g. Use the power tool, accessories and tool bits etc., in accordance with these instructions and in the manner intended for the particular type of power tool, taking into account the working conditions and the work to be performed. Use of the power tool for operations different from intended could result in a hazardous situation.

Service

- a. Have your power tool serviced by a qualified repair person using only identical replacement parts. This will ensure that the safety of the power tool is maintained.

ADDITIONAL SAFETY RULES FOR BENCH GRINDERS

- a. Ensure that the bench grinder is disconnected from the mains supply when not in use, before servicing or making adjustments and when changing accessories such as grinding wheels.
- b. Always use the correct type of grinding wheel for the type of operation to be carried out and the material being machined. Do not use a grinding wheel as a cutting disc.
- c. Only use grinding wheels that are in good condition. This will improve grinding and reduce the load on the machine ensuring a longer life of the grinding wheel and the machine.
- d. Never use damaged grinding wheels. Grinding wheels that are cracked, chipped or worn could shatter causing injury to the operator and bystanders and damage to the machine.
- e. Do not use grinding wheels that are larger than specified, only use grinding wheels that are rated for the machine. The rotational speed shown on the grinding wheel should always be HIGHER than the rotational speed of the machine.
- f. Always fit the blotter or paper washers on either side of the grinding wheel if not already fitted to the grinding wheel.
- g. When fitting a new wheel ensure blotter or paper washers are in place, fit concave side of washers to face the wheel and tighten the lock nut firmly.
- h. Do not over tighten (over tightening can crack a grinding wheel).
- i. Do not attempt to modify the machine or its accessories in any way.
- j. Do not use excessive force on the grinding wheel. Only use gradual pressure as this will reduce the wear on the bench grinder and grinding wheels and increase its efficiency and operating life.
- k. Use approved safety glasses or goggles, face mask and if being used for an extended period wear ear defenders.
- l. Do not start the machine with the work piece in contact with the grinding wheel or before checking the position of the tool rest.
- m. Never apply the work piece to the side of the grinding wheel, this could cause the grinding wheel to shatter.

- n. Keep guards in place and in good working order. With the machine disconnected from the mains supply check that the guards are secure and fitted correctly.
- o. Always keep the tool rest as close to the grinding wheel as possible. The gap between the tool rest and the grinding wheel should be no more than 3mm.
- p. Do not attempt to grind objects that are too small to hold safely.
- q. Do not use the work piece to slow down the grinding wheel once the machine has been switched off.
- r. **WARNING!** Do not use bench grinders in areas where there is a risk of explosion or fire from combustible materials, flammable liquids, paint, varnish, petrol etc. flammable gases and dust of an explosive nature. As a precaution it is recommended that you consult an expert on a suitable fire extinguisher and its use. The metal particles (sparks) which are produced during grinding are hot and could ignite any combustible material in the vicinity of the operation.



WARNING

Ensure the bench grinder is disconnected from the power supply when performing maintenance tasks to avoid injury.

MAINTENANCE REQUIRED	FREQUENCY
Check power cord	Before each use
Inspect wheels for cracks and damage	Before each use
Check moving parts for alignment and binding issues	Before each use
Dress grinding wheels	As needed
Replace grinding wheels	As needed
Vacuum dust from the motor housing	As needed
General cleaning	As needed

WHEEL DRESSING

Wheel dressing is done to renew sharpness or to true up the face of a wheel. A build up of metals and dirt will become embedded in a wheel as it is used. Use a wheel dressing tool (not supplied) to clean wheels on a regular basis. In doing so, it will improve the bench grinder's performance.

NOTE: New wheels may sometimes require dressing to true up their surface.

CLEANING

Use only mild soap and a damp cloth to clean the bench grinder. Never let any liquid get inside the tool. DO NOT immerse any part of the bench grinder into a liquid.

Service beyond recommended maintenance on this bench grinder should only be performed by an authorized, qualified technician.

GETTING STARTED

Accessories

The bench grinder is supplied with the following accessories:
2 eye shields with mounting brackets and 2 tool rests

CAUTION. Always ensure that the bench grinder is switched off and plug is removed from the power point before making any adjustments.

To fit the eye shields locate the nut, screw and washers provided through the slot in the eye shield and hole on the grinding wheel guard and finger tighten. Position the eye shield so it does not come in to contact with the grinding wheel. Tighten the nut and screw to secure the eye shield in place.

Attach the tool rests using the bolts and securing knobs provided and adjust to the correct position. The gap between the tool rest and grinding wheel should be set to 2mm.

Bench Mounting

The Grinder can be secured with screws or nuts and bolts. Locate the mounting holes. The length of the bolts or screws will depend on the thickness of the bench. Where a steel bench is used, it is best to mount the grinder on to a board, then attach the board to the bench, this will also minimize vibration.

Switching On And Off

Before connecting to the power supply rotate the wheel by hand to ensure that it is running properly and free from obstruction. Connect to the mains supply and press the NVR switch to the ON position (I). To stop the machine simply press the switch to the OFF position (O).

General Inspection

Regularly check that all the fixing screws are tight. They may vibrate loose over time.

MULTITOOL BELT & DISC SANDING ATTACHMENTS - SOLD SEPARATELY

PART NO.		DESCRIPTION
P0362		915 x 50mm Belt & Disc Grinding Attachment
P0364		915 x 100mm Belt & Disc Grinding Attachment
P0482		1220 x 50mm Belt & Disc Grinding Attachment
P0484		1220 x 100mm Belt & Disc Grinding Attachment
P08CW		1220 x 100mm (200mm Contact Wheel) Belt & Disc Grinding Attachment
POMTA		Mitre Table Attachment
POJIG		Sharpening Jig

TROUBLESHOOTING

SYMPTOM	CAUSE	CORRECTIVE ACTION
Motor will not start.	<ol style="list-style-type: none"> 1. Low Voltage. 2. Open circuit in motor or loose connections. 3. Blown fuse or breaker. 4. Not plugged in or switched on at wall 	<ol style="list-style-type: none"> 1. Check power source for proper voltage. 2. Inspect all lead connection on motor for loose or open connections. (Send for Servicing.) 3. Short circuit. (Send for Servicing.) 4. Improper match between tool and circuit, fuse or breaker.
Motor will not start – fuses or circuit breakers tripping or blowing.	<ol style="list-style-type: none"> 1. Short circuit in line, cord or plug. 2. Short circuit in motor or loose connections. 3. Incorrect fuses or circuit breakers in power line 	<ol style="list-style-type: none"> 1. Inspect cord or plug for damaged insulation and shorted wires. 2. Inspect all connections on motor for loose or shorted terminals and/or worn insulation. 3. Install correct fuses or circuit breakers or switch tool to an appropriately sized circuit.
Motor overheats.	<ol style="list-style-type: none"> 1. Motor overloaded. 2. Extension cord too long and insufficient gauge (weight). 	<ol style="list-style-type: none"> 1. Reduce load on motor. 2. Utilize an extension cord of appropriate gauge and length or plug tool directly into outlet.
Motor stalls (resulting in blown fuses or tripped circuit).	<ol style="list-style-type: none"> 1. Short circuit in motor or loose connections. 2. Low voltage. 3. Incorrect fuses or circuit breakers in power line. 4. Motor overload. 	<ol style="list-style-type: none"> 1. Inspect connections on motor for loose or shorted terminals or worn insulation. (Send for Servicing.) 2. Correct low voltage conditions (for example: improper extension cord length and/or gauge). 3. Install correct fuses or circuit breakers or plug tool into an appropriate circuit, matched to an appropriate fuse or breaker. 4. Reduce the load on the motor.
Machine slows when operating.	<ol style="list-style-type: none"> 1. Feed rate too great. 	<ol style="list-style-type: none"> 1. Reduce the rate at which the workpiece is fed into the working area of the tool
Wavy condition on surface of workpiece	<ol style="list-style-type: none"> 1. Machine vibrating. 2. Workpiece is not being held firmly 3. Wheel face uneven. 4. Wheel is too hard. 	<ol style="list-style-type: none"> 1. Ensure machine is securely mounted on a solid surface. 2. Use a holding device to firmly retain the workpiece. 3. Dress the grinding wheel. 4. Use softer wheel, or reduce the feed rate.
Lines on surface of workpiece.	<ol style="list-style-type: none"> 1. Impurity on surface of wheel. 2. Workpiece not being held tightly 	<ol style="list-style-type: none"> 1. Dress the grinding wheel. 2. Try holding the device to more firmly retain
Burning spots or cracks in the workpiece.	<ol style="list-style-type: none"> 1. Improper type of grinding wheel. 2. Improper feed rate. 	<ol style="list-style-type: none"> 1. Try wheels with softer bond or coarser grit. 2. Slow down the rate at which the workpiece is fed into the wheel.
Wheel dulls quickly, grit falls off	<ol style="list-style-type: none"> 1. Feed rate is too aggressive. 2. Wheel is soft. 3. Wheel diameter too small. 4. Bad wheel dressing. 5. Defective wheel bonding. 	<ol style="list-style-type: none"> 1. Decrease feed rate of workpiece into grinding wheel. 2. Select a grinding wheel with a harder bond of material. 3. Replace wheel. 4. Dress the wheel. 5. DO NOT USE – return wheel to point of purchase
Wheel clogs and workpiece shows burn marks.	<ol style="list-style-type: none"> 1. Wheel is too hard. 2. Feed rate is too slow. 3. Bad wheel dressing. 	<ol style="list-style-type: none"> 1. Select a grinding wheel with a softer bond of material. 2. Increase the feed rate of the workpiece into the grinding wheel. 3. Dress the wheel.