



1/4" Air Die Grinder

Item No : QA-313



● The consumable parts ▲ The replacement parts ★ The non-replacement parts

Part List QA-313

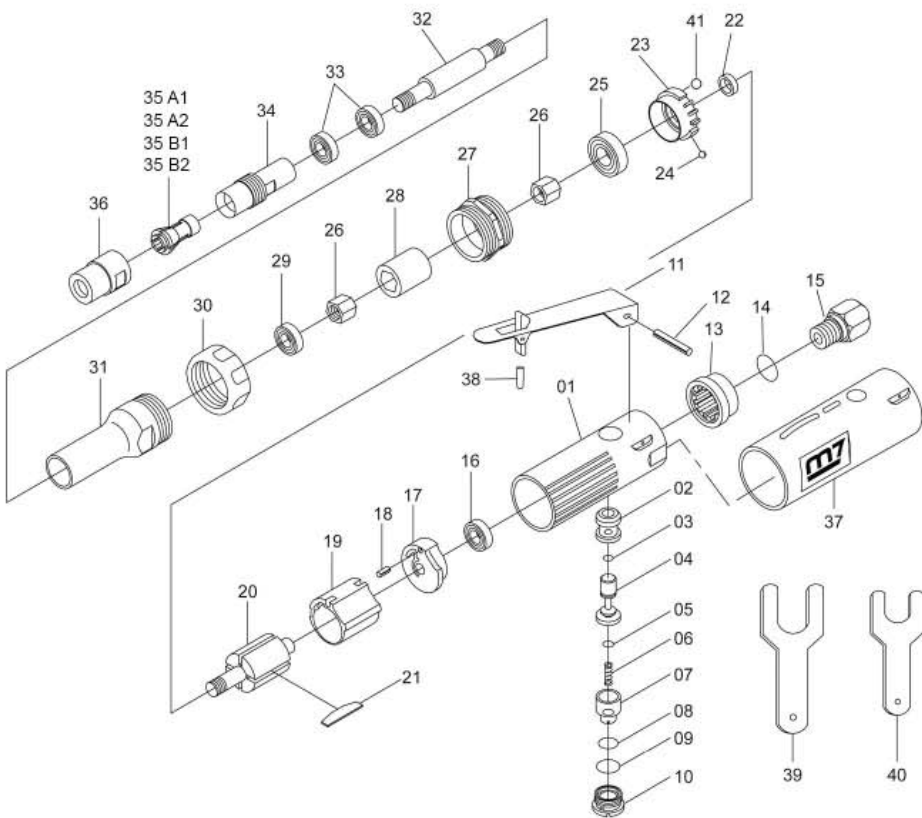

	NO.	PART NO.	DESCRIPTION	Q'TY
★	1	QA-313P01	Motor Housing	1
★	2	QA-313P02	Throttle Bushing	1
▲	3	QA-313P03	O-Ring	1
★	4	QA-313P04	Valve Stem	1
▲	5	QA-313P05	O-Ring	1
★	6	QA-313P06	Spring	1
★	7	QA-313P07	Regulator	1
▲	8	QA-313P08	O-Ring	1
▲	9	QA-313P09	O-Ring	1
★	10	QA-313P10	Throttle Valve Plug	1
★	11	QA-313P11	Throttle Lever	1
★	12	QA-313P12	Spring Pin	1
★	13	QA-313P13	Exhaust Plate	1
▲	14	QA-313P14	O-Ring	1
★	15	QA-313P15	Air Inlet Bushing	1
▲	16	QA-313P16	Ball Bearing	1
▲	17	---	Rear End Plate	1
▲	18	---	Spring Pin (2pcs)	1 Set
★	19	QA-313P19	Cylinder	1
★	20	QA-313P20	Rotor	1
●	21	QA-313T21	Rotor Blade (4pcs)	1 Set
★	22	QA-313P22	Rotor Collar	1
▲	23	---	Front End Plate	1
▲	24	---	Steel Ball	1
▲	25	QA-313P25	Ball Bearing	1
★	26	---	Clamp Nut	1
★	27	QA-313P27	Motor Clamp	1
▲	28	QA-313P28	Coupling	1
★	29	---	Ball Bearing	1

	NO.	PART NO.	DESCRIPTION	Q'TY
★	30	---	Clamp Nut	1
★	31	---	3" Extension Housing	1
★	32	---	Spindle	1
★	33	---	Ball Bearing	1
★	34	---	Collet Sleeve	1
●	35A1	QA-313P35A1	Collet 3 mm	1
●	35A2	QA-313P35A2	Collet 6 mm	1
●	35B1	QA-313P35B1	Collet 1/8"	1
●	35B2	QA-313P35B2	Collet 1/4"	1
★	36	QA-313P36	Collet Nut	1
★	37	QA-313P37	Grip	1
★	38	QA-313P38	Pin	1
★	39	QA-313P39	17 mm Spanner Wrench	1
★	40	QA-313P40	11 mm Spanner Wrench	1
▲		QA-313T01	Rear End Plate Ass'y (17.18)	1 Set
▲		QA-313T02	Front End Plate Ass'y (18.23.24)	1 Set
★		QA-313T03	3" Extension Housing Ass'y (26.29~34)	1 Set