

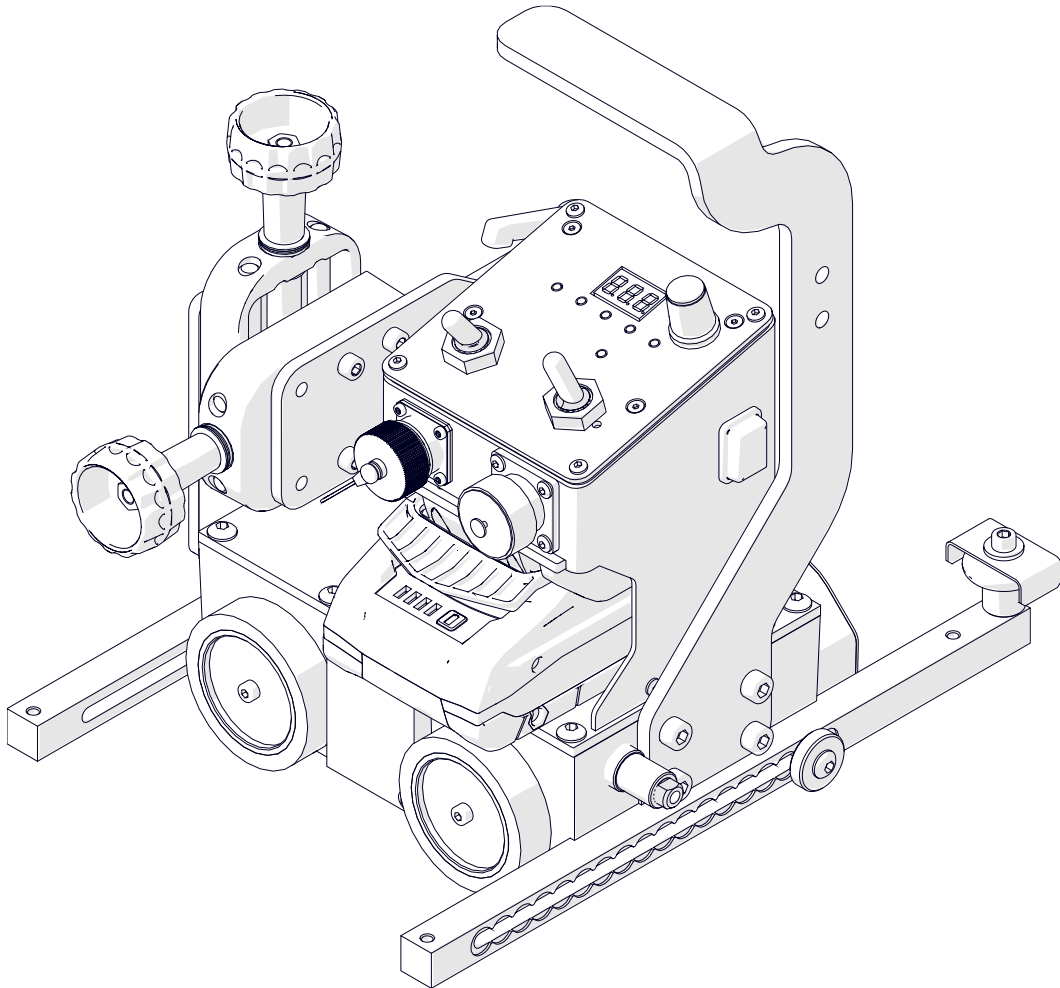

OPERATOR'S MANUAL

WELDING CARRIAGE

SCORPIO BATTERY



PART NO: WA-SCORPIO

Contents

| | |
|--|----|
| 1. BATTERY OPERATION | 3 |
| 1.1. Safety precautions | 3 |
| 1.2. Specified Use..... | 3 |
| 1.3. Operating | 4 |
| 1.4. Environmental protection | 4 |
| 2. GENERAL INFORMATION | 5 |
| 2.1. Application | 5 |
| 2.2. Technical data | 5 |
| 2.3. Equipment included | 6 |
| 2.4. Dimensions | 7 |
| 2.5. Design..... | 8 |
| 3. SAFETY PRECAUTIONS | 9 |
| 4. STARTUP AND OPERATION..... | 11 |
| 4.1. Preparing | 11 |
| 4.2. Connecting to the welding circuits | 12 |
| 4.3. Positioning at the work area | 14 |
| 4.4. Operating | 16 |
| 4.5. Changing the unit of speed..... | 19 |
| 4.6. Troubleshooting | 19 |
| 4.7. Maintenance | 21 |
| 5. ACCESSORIES | 22 |
| 5.1. Torch holders, clamps, and rods | 22 |
| 5.2. Guide arms | 24 |
| 5.1. Pendulum oscillator | 26 |
| 5.2. 76 mm cross slide..... | 27 |
| 5.1. Cable anchor | 28 |
| 5.2. Torch extension arm | 28 |
| 5.3. Dual torch mount | 29 |
| 5.4. Flexible guide set..... | 30 |
| 5.5. Guide adjustment tool..... | 32 |
| 5.6. Flexible trackway set | 33 |
| 5.7. Magnetic units for flexible trackway | 36 |
| 5.8. Support for flexible trackway with magnetic units | 40 |
| 5.9. Vacuum unit..... | 40 |
| 5.10. Support for flexible trackway with vacuum units | 41 |
| 5.11. Vacuum Track System..... | 42 |
| 5.12. Stainless steel wheels | 42 |
| 5.13. Battery 4 Ah | 43 |
| 5.14. Charger..... | 43 |

1. BATTERY OPERATION

1.1. Safety precautions

- Before using the battery, read the entire operator's manual carefully and thoroughly. Keep safe all documents accompanying the battery.
- Protect the battery from water and moisture.
- Do not use faulty or deformed battery.
- Do not open the battery and do not short-circuit its contacts.
- Keep the battery out of the reach of children.
- Do not expose the battery to fire or high temperatures.
- Slightly acidic, flammable fluid may leak from a defective li-ion battery. In case it comes into contact with your skin, rinse immediately with plenty of water. In case it comes into contact with your eyes, wash them with clean water and seek medical attention immediately.
- Transporting li-ion battery packs:
The shipping of li-ion battery packs is subject to laws relating to the carriage of hazardous goods (UN 3480 and UN 3481). Inform yourself of the currently valid specifications when shipping. If necessary, consult your freight forwarder. Certified packaging is available from Promotech.
- Do not allow full discharge. Do not store discharged battery.



1.2. Specified Use

The battery is designed for use in corresponding Promotech battery-operated power tools. The battery must only be charged using Promotech charger. Battery packs marked with CAS are 100% compatible with CAS devices (Cordless Alliance System). To select the appropriate device, please contact your dealer. Read the relevant instructions for the devices used. For example, the charging process is explained in the charger manual. The user bears sole responsibility for any damage caused by improper use. Generally accepted accident prevention regulations and the safety information must be observed.

1.3. Operating

Charge the battery before the first use. Do not charge fully charged battery. If performance diminishes, recharge the battery. The ideal storage temperature is between 10°C and 30°C. The permissible charging temperature is between 0°C and 50°C.

The battery has a capacity and a signal indicator (depending on the model). Press the button (1) and the charge level is displayed by the LEDs (2). If one LED flashes (3), the battery is almost flat and must be recharged.

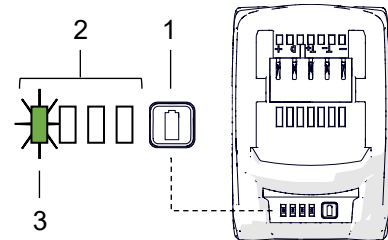

1.4. Environmental protection



In accordance with the European Directive 2006/66/EC, the batteries are marked with the symbol of the crossed-out waste bin. Below this symbol there may be a chemical symbol of heavy metal present in the battery, if its percentage is above: 0.0005% for mercury (Hg), 0.002% for cadmium (Cd), 0.004% for lead (Pb). Batteries must not be disposed of with household waste and WEEE waste. The user must return the battery to a collection point for used batteries. Before returning the battery, discharge it*, remove it from the device and protect the contacts with insulating tape.



Returning the battery to the collection point reduces the negative impact of its hazardous substances on human health and the environment, and enables the recovery of raw materials and plastics in the recycling process.



* refers to undamaged batteries

2. GENERAL INFORMATION

2.1. Application

The SCORPIO BATTERY is a welding carriage designed to make butt and fillet welds that are continuous or stitch. The carriage allows MIG/MAG torches and is clamped with permanent magnets. The carriage is battery-powered.

Accessories allow welding with oscillation, using torches with a larger diameter, and using two torches at the same time.

The machine is designed for use by a professional operator only.

2.2. Technical data

| | | |
|--|--|--------------------|
| Voltage | 18 V DC, 4 Ah | |
| Power | 18 W | |
| Welding position (according to EN ISO 6947 and AWS/ASME) | PA/1F/1G PB/2F PC/2G | |
| Minimum path curve radius | Outer | 1000 mm (39 3/8") |
| | Inner | 1250 mm (49 7/32") |
| Torch type | MIG/MAG | |
| Torch diameter | 16–22 mm (5/8"–55/64") | |
| Horizontal pulling force | 150 N | |
| Horizontal speed (with a fully charged battery) | 5–130 cm/min (1–51 in/min) | |
| Weight (without the battery) | 7 kg (15.4 lbs) | |
| Maximum torch reach | 70 mm (2 3/4") | |
| Minimum workpiece thickness | 4 mm (5/32") | |
| Ground clearance | 4 mm (5/32") | |
| Cross slide adjustment range | 0–35 mm (0–1 3/8") (up-down, left-right) | |
| Standard guide arms adjustment range | 170 mm (6 11/16") | |
| Maximum allowed cable weight for horizontal work | 8 kg (17.6 lbs) | |
| Protection class | I | |
| Protection level | IP 20 | |
| Required ambient temperature during operation | 0–50°C (32–122°F) | |
| Required ambient temperature during storage | -10–60°C (14–140°F) | |
| Maximum allowed ambient humidity without condensation | 80% | |

2.3. Equipment included

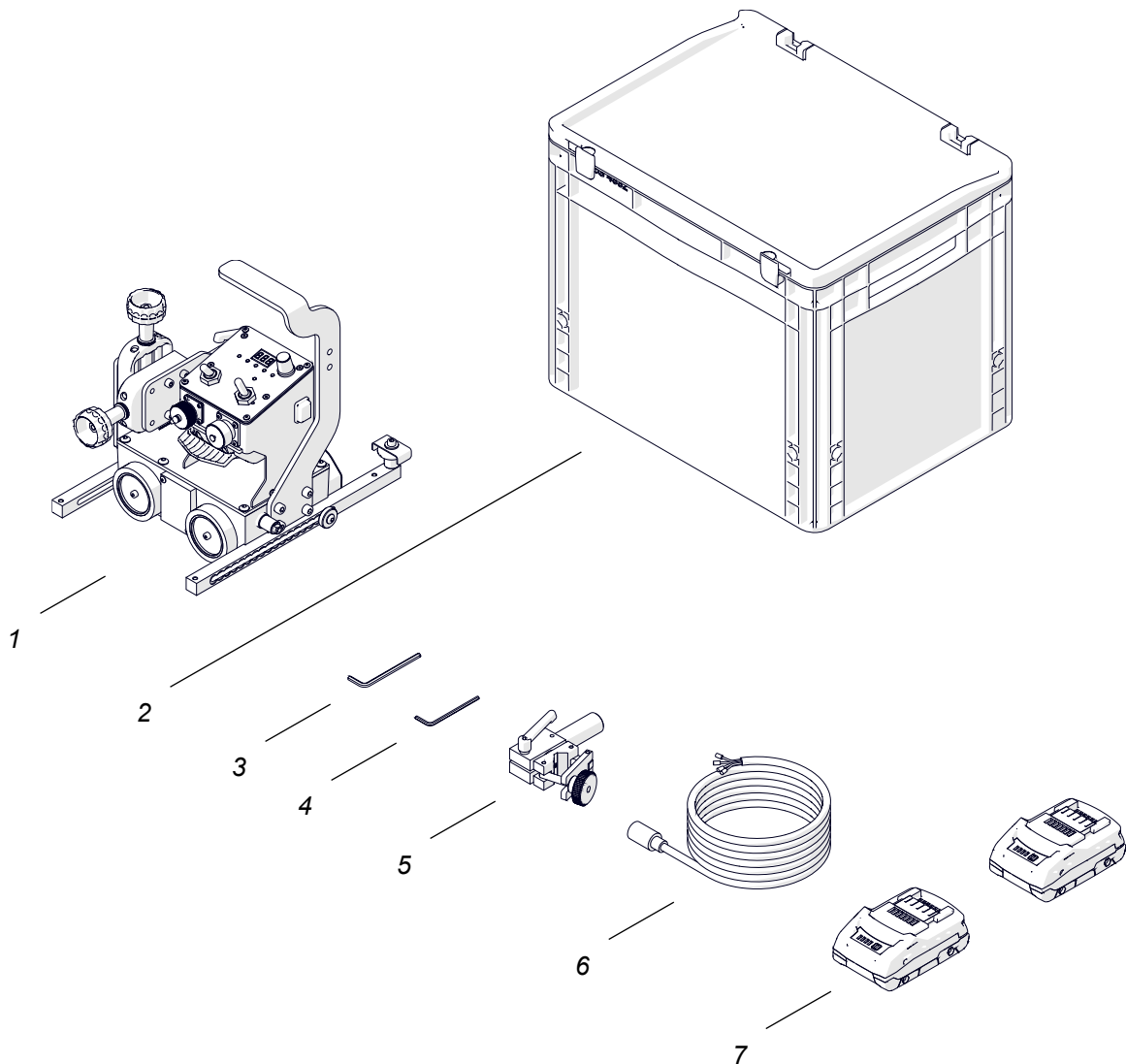

| | | |
|---|--------------------|---------|
| 1 | Carriage | 1 unit |
| 2 | Box | 1 unit |
| 3 | 4 mm hex wrench | 1 unit |
| 4 | 3 mm hex wrench | 1 unit |
| 5 | Torch holder | 1 unit |
| 6 | Arc ignition cable | 1 unit |
| 7 | Battery 4 Ah | 2 units |
| – | Operator's manual | 1 unit |

2.4. Dimensions

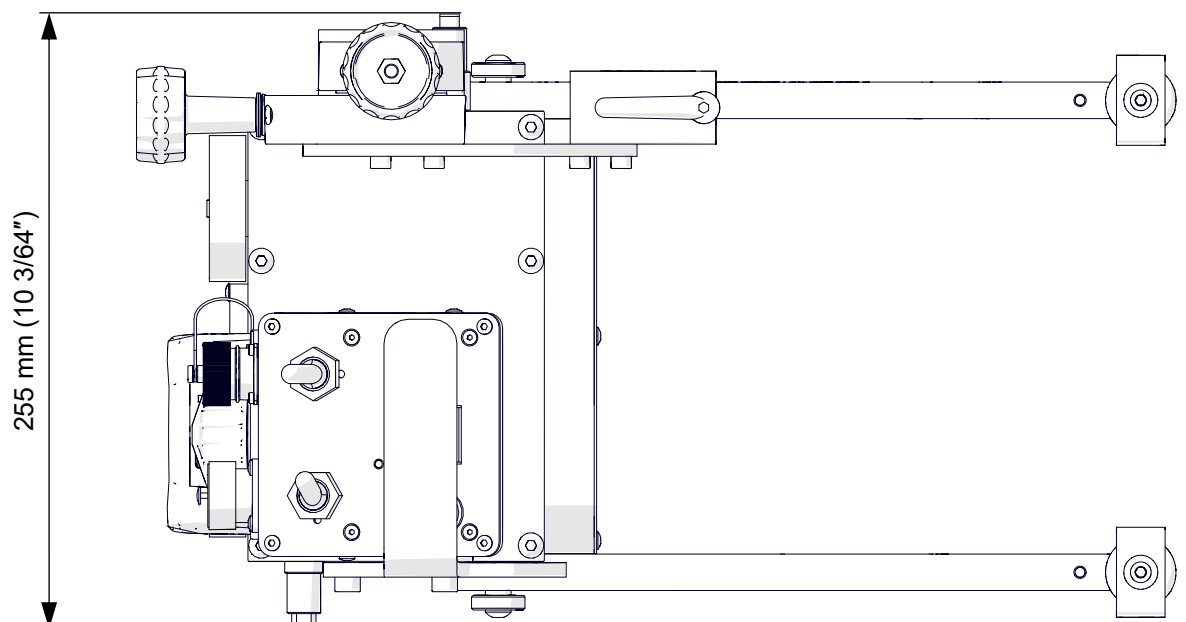
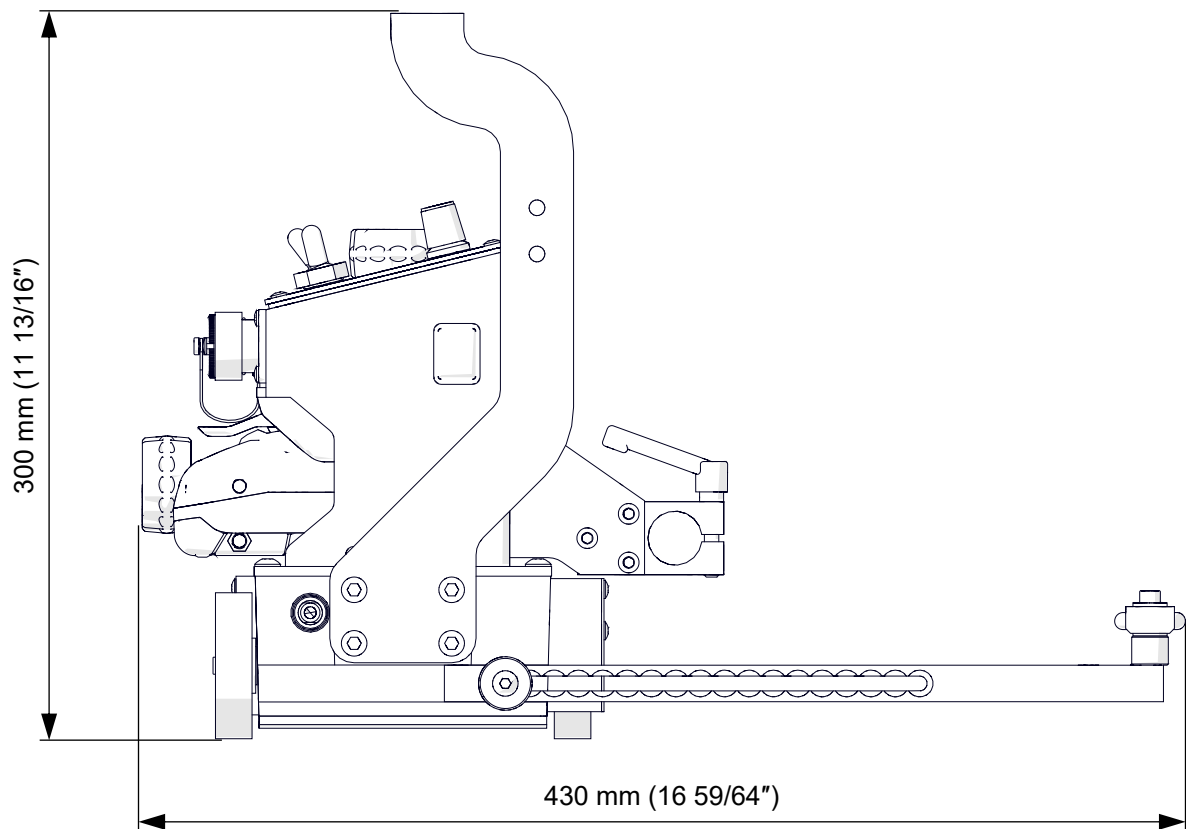

2.5. Design

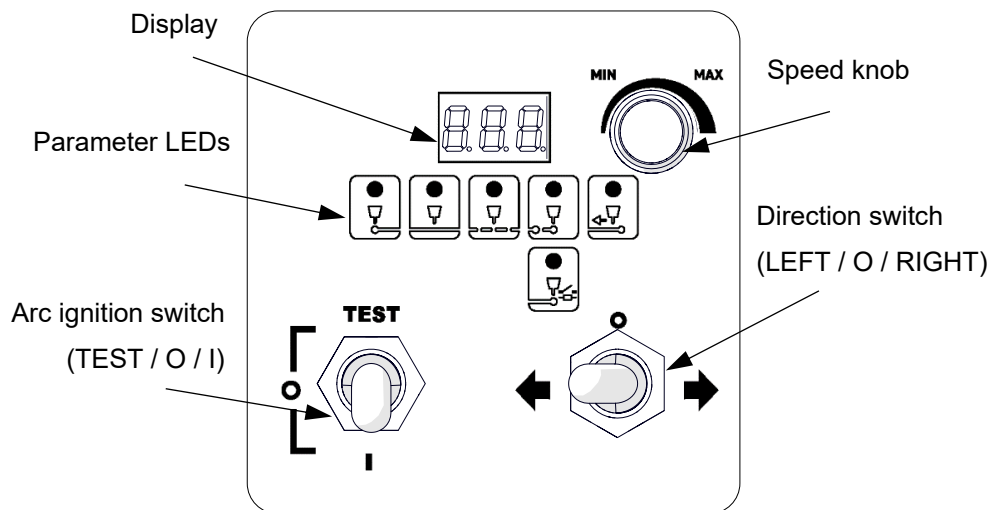
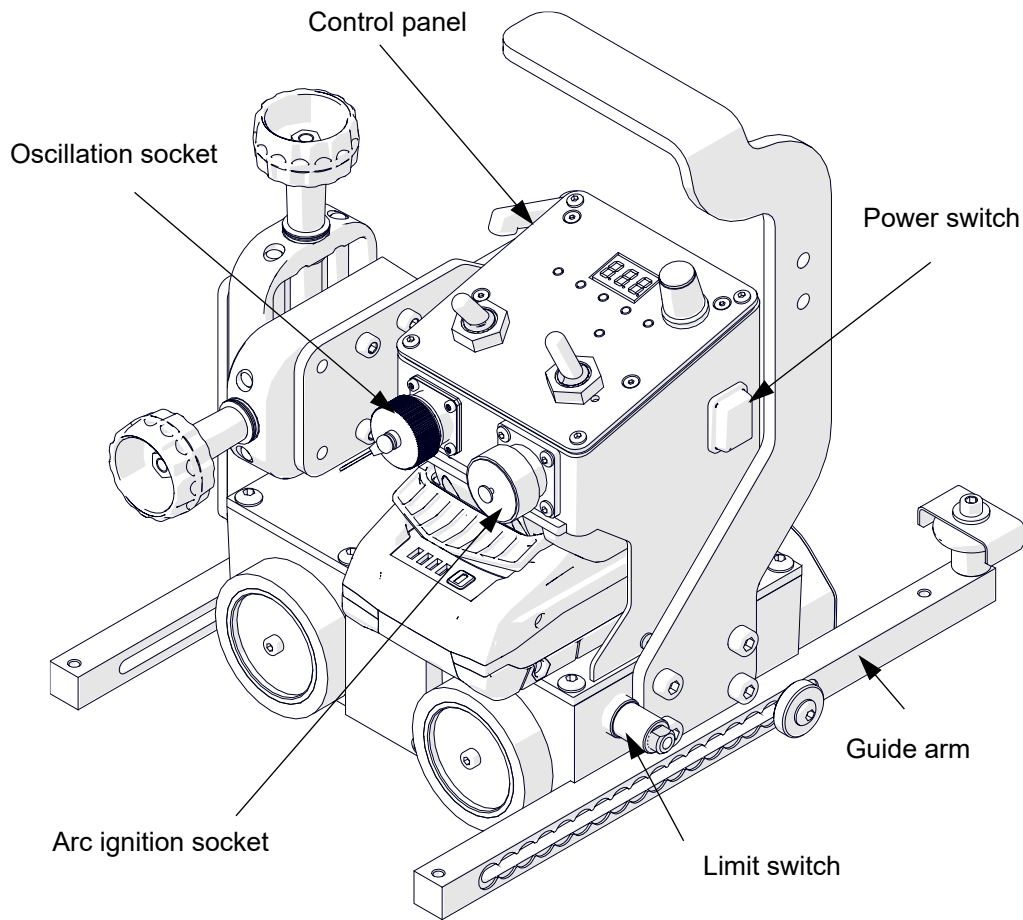

3. SAFETY PRECAUTIONS

1. Before use, read this operator's manual and complete a training in occupational safety and health.
2. Use only in applications specified in this operator's manual.
3. Make sure that the machine has all parts and they are genuine and not damaged.
4. Keep untrained persons away from the machine.
5. Before each use, ensure the correct condition of the machine, cables, plugs, sockets, control panel, and wheels.
6. Before each use, make sure that no part is cracked or loose. Make sure to maintain correct conditions that can have an effect on the operation of the machine.
7. Keep the machine dry. Do not expose the machine to rain, snow, or frost.
8. Do not expose the machine to fire or excessive temperature.
9. Keep the work area well-lit, clean, and free of obstacles.
10. Do not use in explosive environments or near flammable materials.
11. Make sure that the rubber of the wheels is clean and not damaged.
12. Do not remove the cover of the wheels.
13. Remove objects attracted to the chassis by the magnet.
14. Transport and position the carriage by using the carrying handle.
15. Put the carriage so that four wheels are on the surface. Make sure that no contact is between the surface and chassis.
16. Install only MIG/MAG torches whose diameter is the same as the diameter of the torch holder.
17. Do not put the torch more than 70 mm (2 3/4") outward from the left or right side of the carriage.
18. Keep the torch cables away from the surface. Hang the hoses to decrease the load applied on the carriage. Use the welding cables whose weight is not more than specified in the technical data.
19. Do not work on curves with convex or concave radius less than specified in technical data.
20. At heights, protect the carriage from falling.
21. Do not stay below the machine that is put at heights.
22. Use eye protection (helmet, shield, and screen), ear protection, gloves, and protective clothing. Do not use loose clothing.

23. Do not stop the machine by hand. To stop, set the direction switch to 'O'.
24. Repair only in a service center appointed by the seller.
25. If the machine falls, is wet, or has any damage, stop the work and immediately send the machine to the service center for check and repair.
26. Do not leave the machine when it operates.
27. Store the machine in a safe and dry place.
28. Install/remove the battery only after you set the direction switch to 'O'.
29. Do not remove the battery during operation of the machine.
30. Do not leave the battery in the machine.
31. Remove the battery before you do maintenance or install/remove parts.
32. Use a battery and charger compatible with the machine, listed in the ACCESSORIES chapter.

4. STARTUP AND OPERATION

4.1. Preparing

Use the carrying handle to transport the carriage to the work area. Set to 'O' all switches (power, direction, and arc ignition switch). Then, put the torch into the torch holder and tighten with the knob.

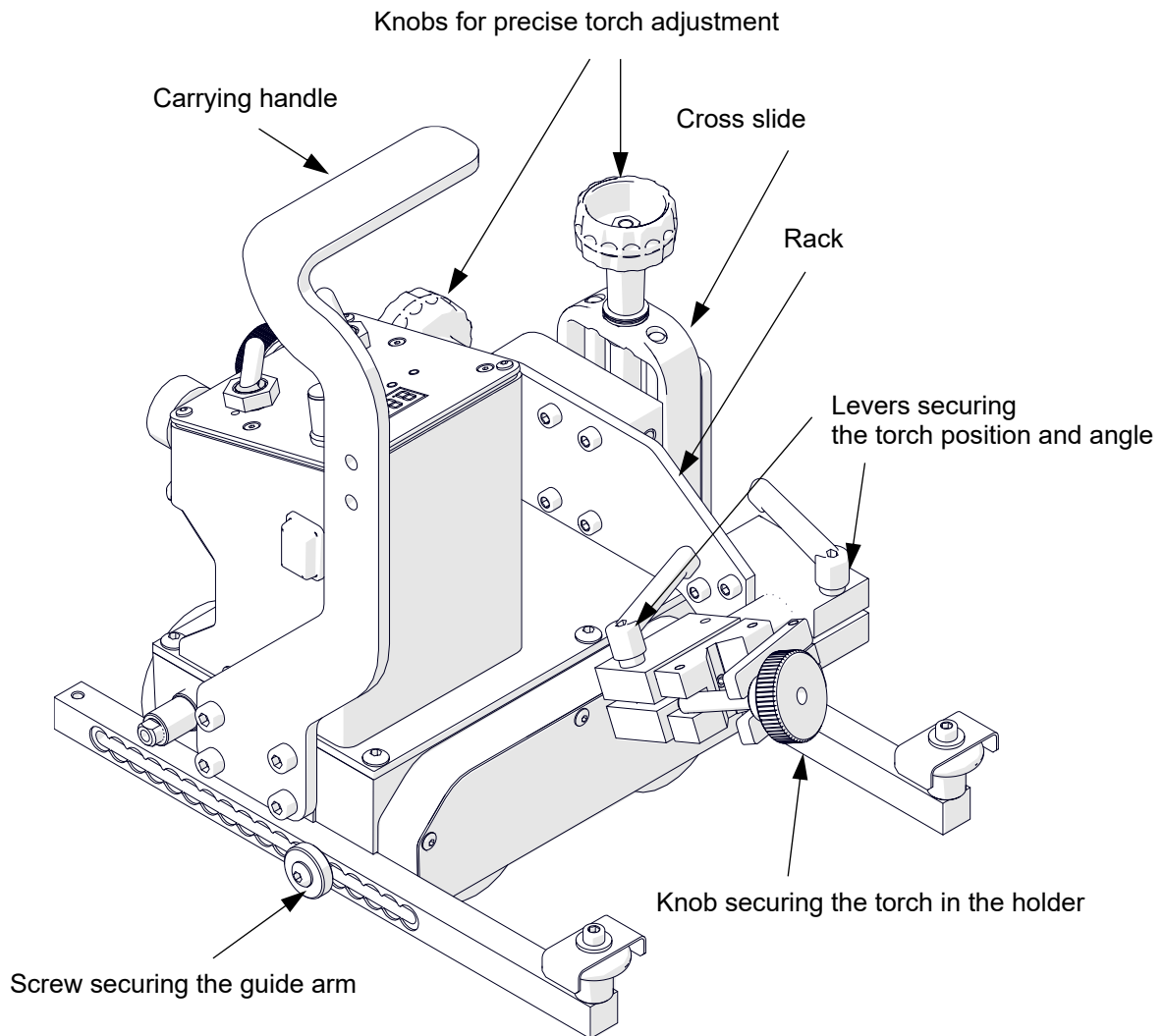

4.2. Connecting to the welding circuits

Before connecting, read the operator's manual of the welding device and make sure that it provides such option. Connect the arc ignition cable only to the arc ignition control contacts in the welding device remote control socket. Make sure that the welding cycle control of the welding device is set to 2-stroke. If you set it to 4-stroke, arc ignition control will work incorrectly.



Do not connect to sockets other than the arc ignition remote control socket, specified by the manufacturer of the welding device. Incorrect connection of the arc ignition cable to the welding device may result in permanent damage to the carriage!

The carriage can be connected to a welding device (welding machine, wire feeder). Make sure that the device provides a start-stop signal (see the operator's manual provided by the manufacturer).

The carriage can control two torches by using the arc ignition cable plugged into the arc ignition socket. To do this, refer to the diagram below and connect one blue-jacketed wire to one terminal of the welding circuit. Then, connect the other blue-jacketed wire to the other terminal of the same circuit. To control the second torch, connect the green-jacketed wires to the terminals of the second welding circuit.

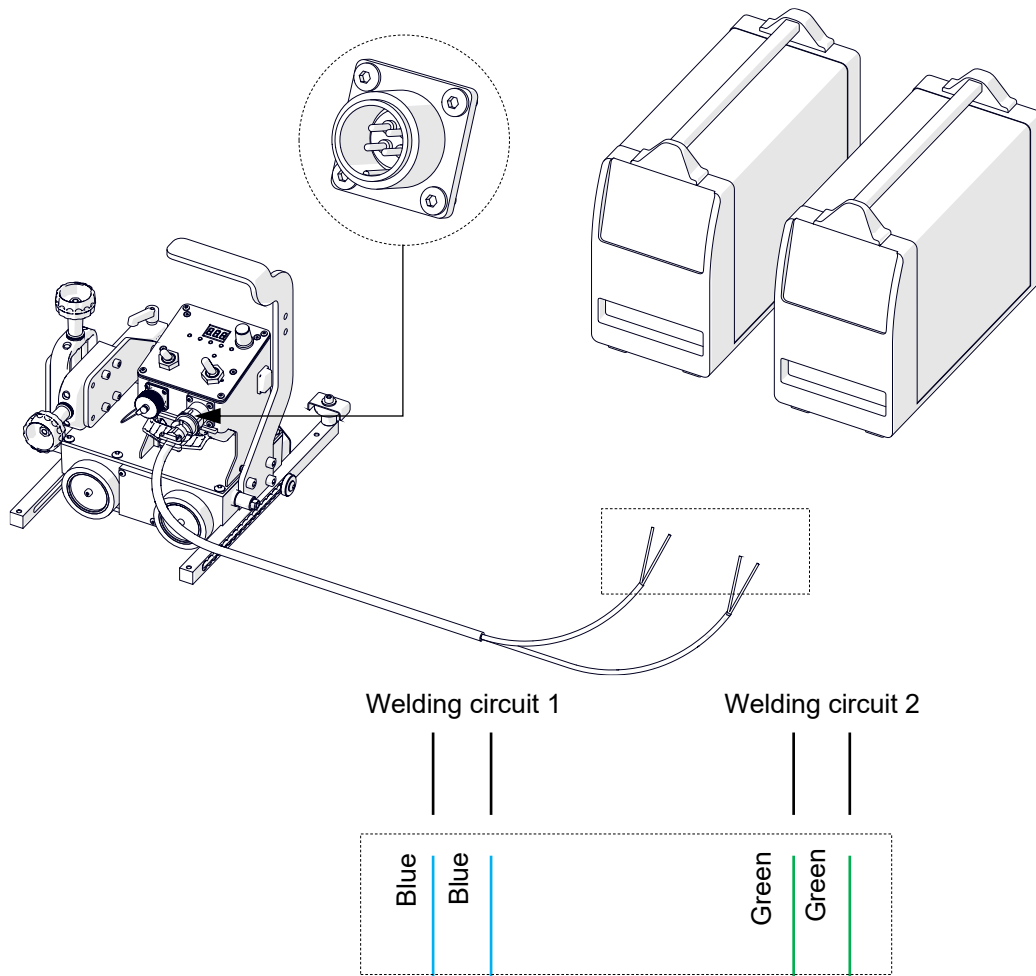

Make sure that the arc ignition cable is connected correctly. To do this, insert the battery, turn on the carriage and then set the arc ignition switch to TEST. This should enable the arc for a while.

4.3. Positioning at the work area

Put the guide arms so that the carriage is in constant contact with the workpiece. You can set them by a constant step (interval adjustment), or continuously after you swap them (continuous adjustment). To set them correctly when the carriage moves to the left, use the 4 mm hex wrench to loosen the screw that secures the right guide arm. Next, move out the right arm about 10 mm (25/64") or one groove more than the left arm, and then tighten the screw again.

When moving to the right, slide out the left guide.

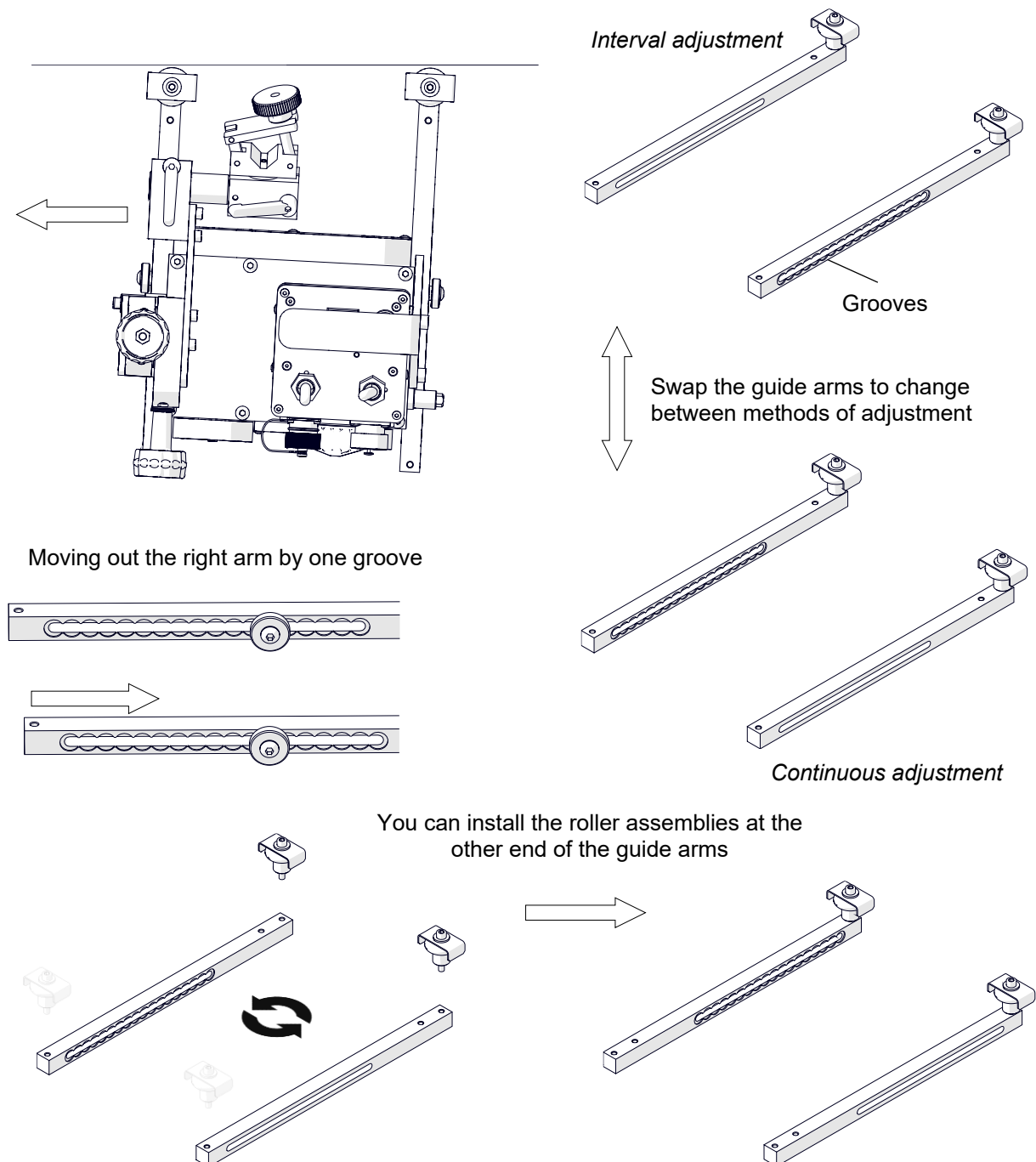

To put the carriage closer to the workpiece, use the 4 mm hex wrench to remove the roller assemblies. Next, install them at the other end of the guide arms, and then swap the guide arms.

Loosen the levers to adjust the position and angle of the torch. Use two knobs at the cross slide to precisely set the torch position.

If the torch position adjustment with the knobs is insufficient, you can:

- a) Move the cross slide (1) up 22 mm – using a 3 mm hex wrench remove the cross slide (2), move it (3) and install with four screws (4).

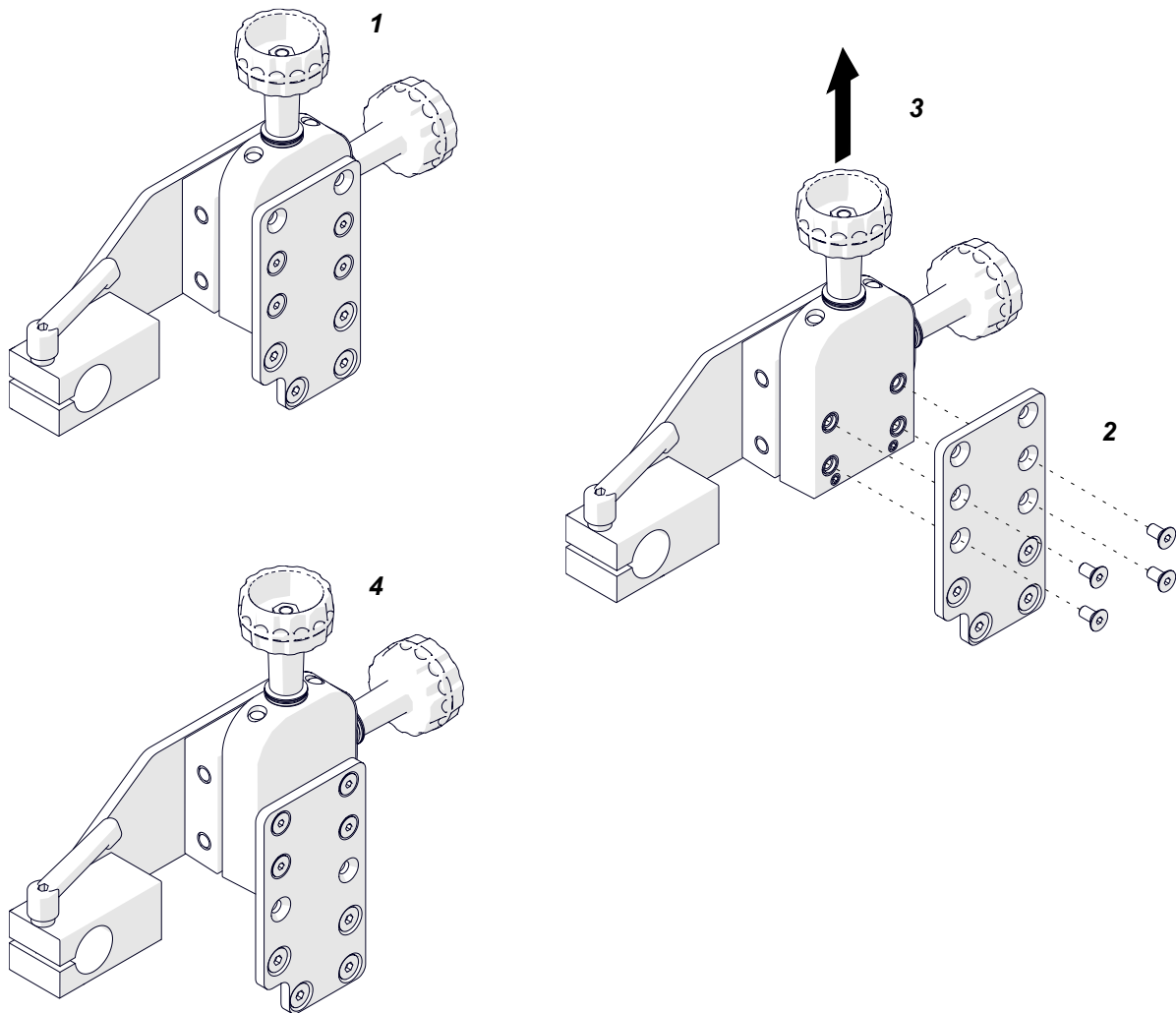

- b) Move the rack (5) forward 22 mm – using a 4 mm hex wrench remove the rack (6), move it (7) and install with four screws (8).

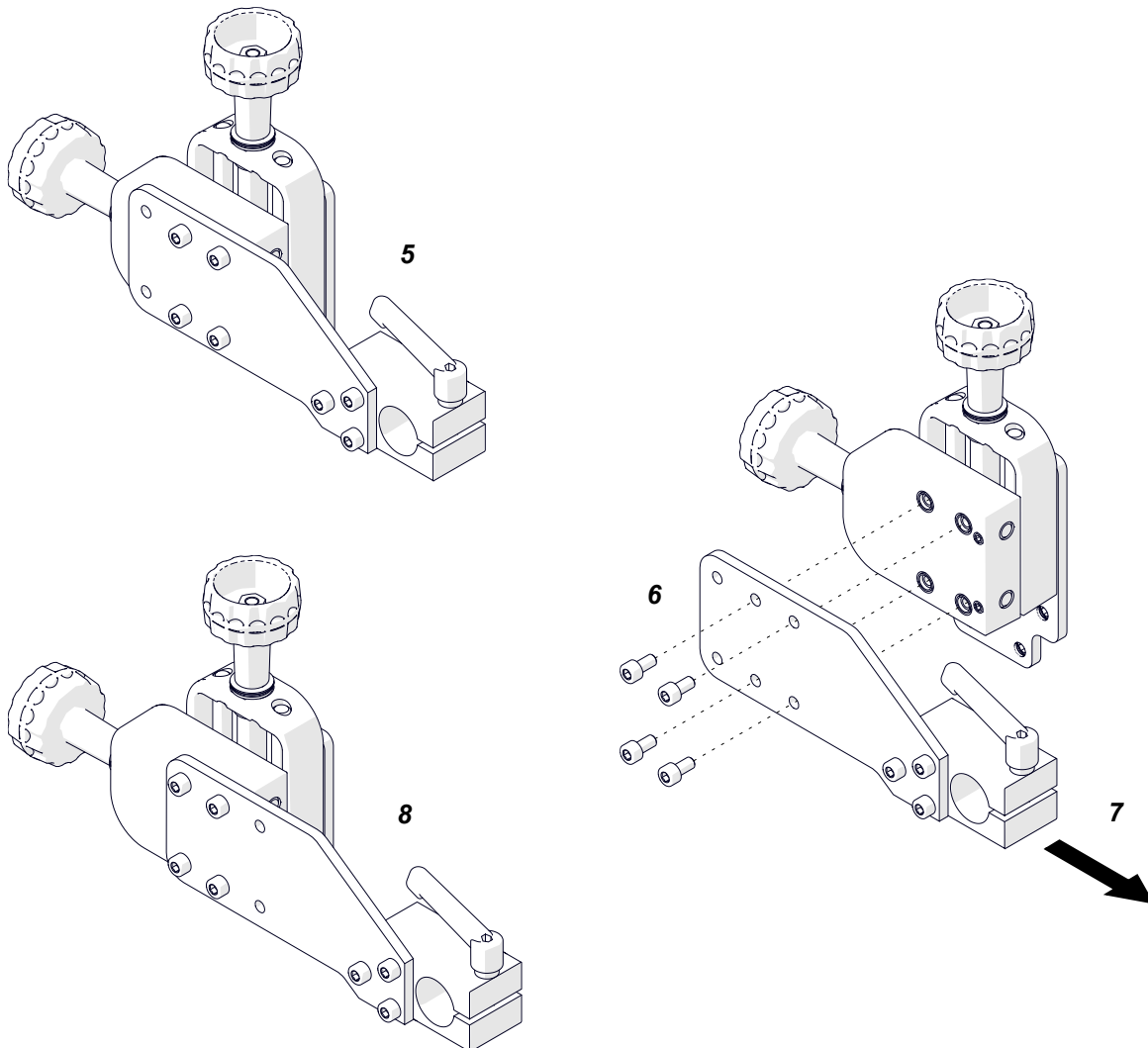

4.4. Operating

Set the power switch to 'I' to turn on the carriage. Then, the display comes on (8.8.8.). Next, the software version shows (e.g. 1.0.0). If the speed unit is set to centimeters per minute, **CM** shows. If the unit is set to inches per minute, **USA** shows. Next, the carriage speed shows. Use the speed knob to set the required speed. To control the torch through the carriage, set the arc ignition switch to 'I'.







If the arc ignition switch is set to 'I', the torch starts welding immediately after you select a travel direction.

To go into the welding settings, press and hold the speed knob for 3 seconds. The LED of the first parameter (Table 1) will light up on the control panel. Set the value by turning the knob. To confirm and move to the next parameter, press the knob. In the case of continuous welding (skip set to zero), the setting of the backweld length is skipped. After setting the total path, you can exit the settings by pressing and holding the knob for 2 seconds.

The availability of parameters may depend on the values of other parameters (see Table 1).

Tab. 1. Parameters

| Parameter | Value | Description |
|---|--|---|
|  | 0–5.0 s [step: 0.1] | Arc stabilization time (АСТ). Filling the crater at the beginning of the weld. |
|  | 0.5–99.9 cm [step: 0.1] 0.5–40" [step: 0.1] | Length of a single weld. |
|  | 0.5–99.9 cm [step: 0.1] 0.5–40" [step: 0.1] | Skip between welds (---). If the skip is set to 0, the carriage welds in continuous mode. |
|  | 0–5.0 s [step: 0.1] | Crater filling time (С F/С F P). Filling the crater at the end of the weld. |
|  | | Behavior of the arc ignition relay while filling the crater. Parameter available when the crater filling time is set to more than 0. |
| | ON | Welding source uses full current while filling the crater. The parameter LED is lit. |
| | OFF (default) | Welding source decreases the current of the arc while filling the crater. Set the crater fill time higher or equal to the time of the current lowering that is set at the welding source. The parameter LED remains off. |

| Parameter | Value | Description |
|---|---|---|
|  | 0–2 cm [step: 0.1] 0–1" [step: 0.1] | Backweld length (- b -). Parameter available when the skip is set to more than 0. The maximum backweld length is equal to the length of a single weld. |
| All LEDs on | 1–999 cm [step: 1] 1–400" [step: 1] INF | Total length. Total length is longer or equal to the sum of weld length and skip. If set to infinity (INF), the program executes until you stop the carriage with the direction switch. |

Figure below shows a graphic description of the welding procedure that starts when you select a movement direction with the direction switch. The first stage is arc stabilization and crater filling at the beginning of the weld. In second stage, the carriage moves with the speed shown and makes a weld of defined length. Next, the carriage does the crater filling (stage 3) and then does the backweld (stage 4). In stage five, the carriage moves to the start of next weld and stage one begins again. This procedure is repeated until the carriage reaches total length. Then the carriage does the crater filling and the welding ends (stage 6).



After total length (E n d) is reached, set the direction switch to 'O'.

To stop the carriage, set the direction switch to 'O'.

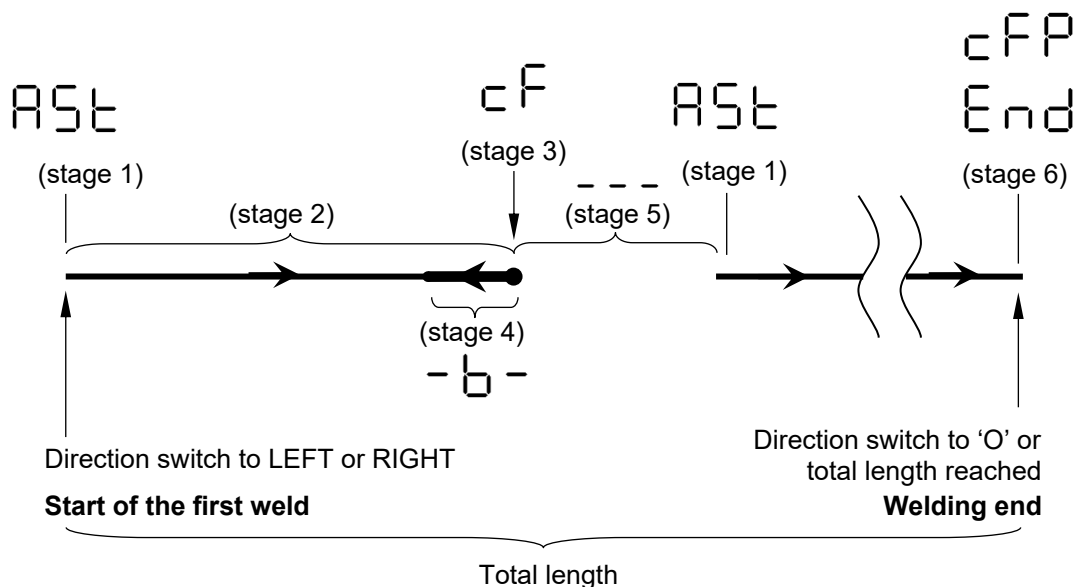
If you do not use the carriage for 5 minutes, it turns off. To turn the carriage back on, set the power switch to 'O' and then to 'I'.

When the battery is discharged, the carriage stops. Then, charge the battery.

After the work is finished, use the power switch to turn off the carriage. Then remove the battery.

4.5. Changing the unit of speed

To change the speed unit, first turn off the carriage by setting the power switch to 'O'. Then press and hold the speed knob and set the power switch to 'I' at the same time. The display shows the currently used unit. By turning the knob, go to centimeters per minute (EUR) or inches per minute (USA). To select, press the speed knob. Then the carriage turns on and displays the set speed unit.

4.6. Troubleshooting

| Message | Problem | Solution |
|----------------|--|---|
| - | Black display even though that the power switch is set to 'I'. The carriage was not used for 5 minutes and then it turned off. | Set the power switch to 'O' and then to 'I'. |
| 0.55 | Display not fully on when powering. | Contact the service center for check and repair. |
| EUR | Speed shown in centimeters per minute instead of inches per minute. | Refer to the section "Changing the unit of speed". |
| USA | Speed shown in inches per minute instead of centimeters per minute. | Refer to the section "Changing the unit of speed". |
| Er.S | Travel direction switch not set to 'O' when powering. | Set the direction switch to 'O'. |
| | Shown during travel indicates a malfunction. | Contact the service center for check and repair. |
| Er.A | Arc ignition switch not set to 'O' when powering. | Set the arc ignition switch to 'O'. |
| LS.r | Carriage reached an obstacle on the right. | Remove the obstacle that blocks the carriage or choose the opposite |

| Message | Problem | Solution |
|---------|---|--|
| L5L | Carriage reached an obstacle on the left. | direction to move the carriage from the obstacle. Then set the direction switch to 'O'. If the message shows after turning on the carriage, remove the obstacle that blocks the carriage. |
| oC | Motor overload. The carriage stops. | Remove objects that block the carriage. Adjust the position of the cables so that they do not block the carriage. Use the welding cables whose weight is not more than the maximum weight specified in the technical data. |
| E.01 | Battery voltage too low. | Charge the battery or replace to a fully charged. |
| E.02 | Battery voltage too high. | Replace the battery. |
| E.03 | Motor power supply too low. | Contact the service center for check and repair. |
| E.10 | Short circuit. | Clean the battery contacts. If the problem persists, replace the battery. If the error persists after replacement, contact the service center. |
| E.20 | No electrical connection. | |
| E.30 | Battery internal error. | Replace the battery. |
| E.40 | Battery overheated. | Let the temperature of the battery decrease. |
| E.50 | Battery temperature too low. | Move the battery to a warmer place and let the temperature of the battery increase. |

If there are two errors, the messages can be combined into one, e.g E.01 + E.50 = E.51.

4.7. Maintenance

Every day:

1. Clean the chassis and wheels.
2. Clean the rollers of the guide arms. Make sure that the rollers turn freely.
3. Clean the torch nozzle and replace if damaged.
4. Examine the battery and replace if damaged.

Every month:

1. Make sure that the knobs and the switches work as intended. Replace if they are loose or damaged.
2. Examine hoses and cables and replace if they are damaged.
3. Tighten screws if they are loose.

5. ACCESSORIES

5.1. Torch holders, clamps, and rods

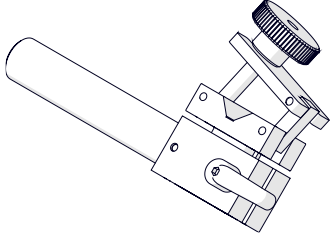
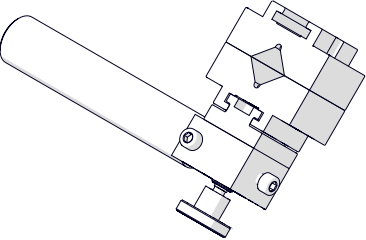
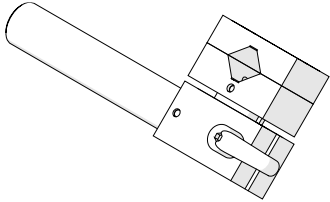
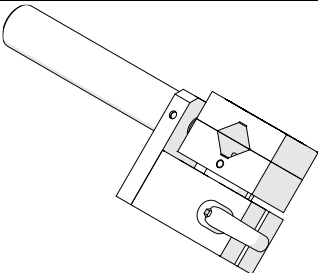
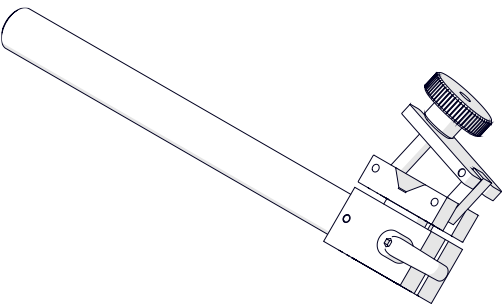
| | |
|---|-------------------------------------|
| Short rod torch holder with clamp 16–22 mm | |
|  | Part number: UCW-0754-07-00-00-0 |
| Quick-release short rod torch holder with clip 16–22 mm | |
|  | Part number: UCW-0523-84-00-00-0 |
| Short rod torch holder with clip 16–22 mm | |
|  | Part number: UCW-0476-27-00-00-0 |
| Short low rod torch holder with clip 16–22 mm | |
|  | Part number: UCW-0476-06-00-00-0 |
| Long rod torch holder with clamp 16–22 mm | |
|  | Part number: UCW-0752-07-00-00-0 |

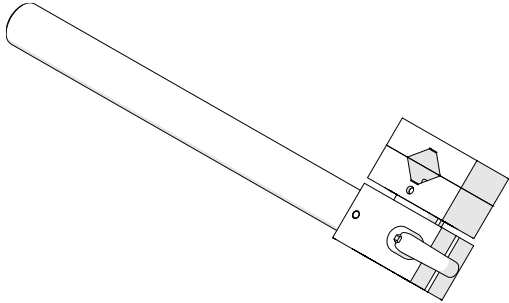
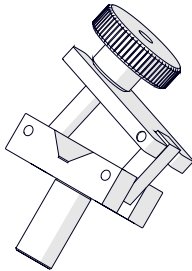
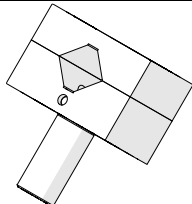
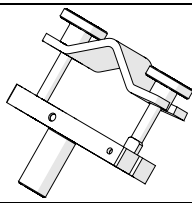
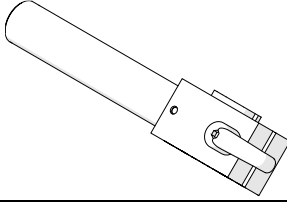
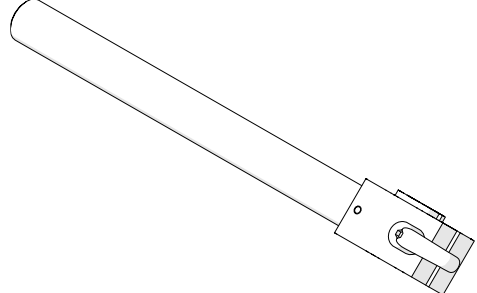
| | |
|---|-------------------------------------|
| Long rod torch holder with clip 16–22 mm | |
|  | Part number: UCW-0466-22-00-00-0 |
| Torch clamp 16–22 mm | |
|  | Part number: ZRZ-0752-07-01-00-0 |
| Torch clip 16–22 mm | |
|  | Part number: ZCS-0476-06-01-00-0 |
| Torch clamp 22–35 mm | |
|  | Part number: ZRZ-0466-19-00-00-0 |
| Short rod | |
|  | Part number: WLK-0476-20-01-00-0 |
| Long rod | |
|  | Part number: WLK-0466-04-10-00-0 |

5.2. Guide arms

Use the 4 mm hex wrench to remove the standard guide arms and install the new guide arms.

5.2.1. Adjustable guide arms

Allow guiding the carriage along lap joints and templates.

Adjustment range: 145 mm (5 45/64").

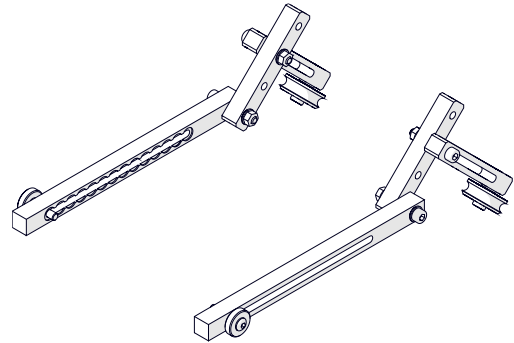
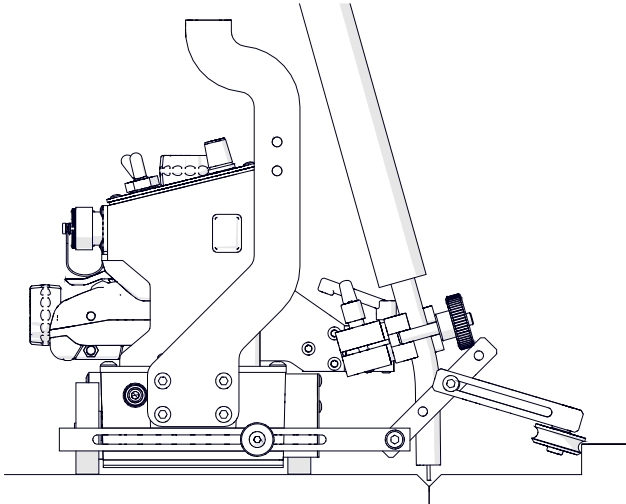

Part number (2 units):
PRW-0752-10-00-00-1

5.2.2. Magnet guide arms

Allow guiding the carriage on ceilings.

Adjustment range: 100 mm (3 15/16").

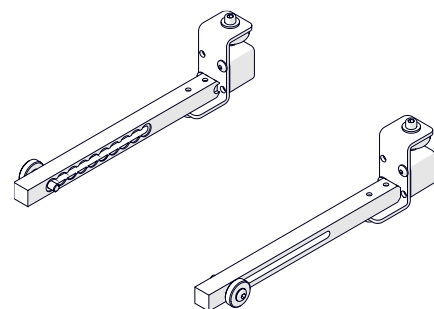
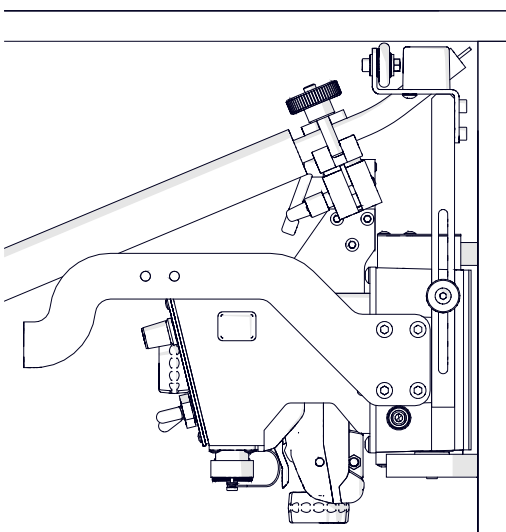

Part number (2 units):
PRW-0752-11-00-00-1

5.2.3. Low guide arms

Allow guiding the carriage along low walls.

Adjustment range: 170 mm (6 11/16").

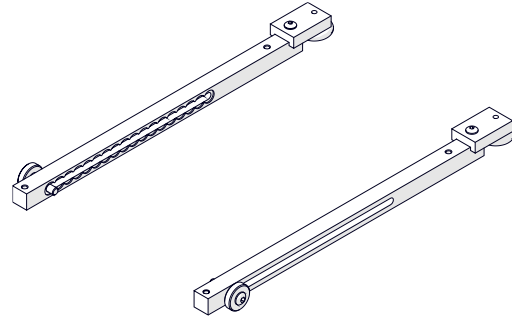
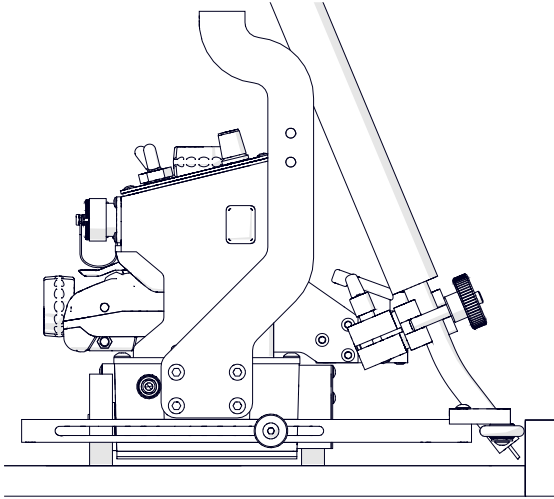

Part number (2 units):
PRW-0752-12-00-00-1

To put the carriage closer to the workpiece, use the 3 mm hex wrench to remove the roller assemblies. Next, install them at the other end of the guide arms, and then swap the guide arms.

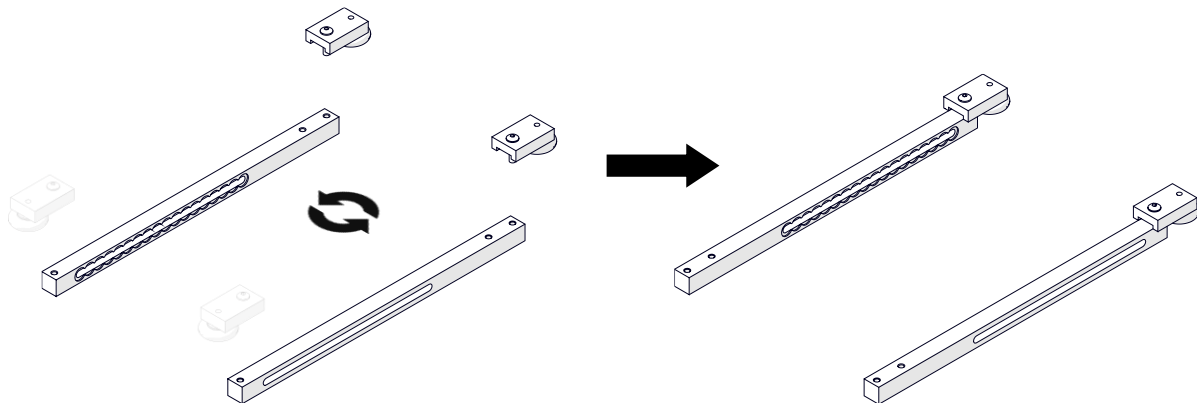

5.2.4. High guide arms

Allow guiding the carriage along walls that have holes.

Adjustment range: 100 mm (3 15/16").

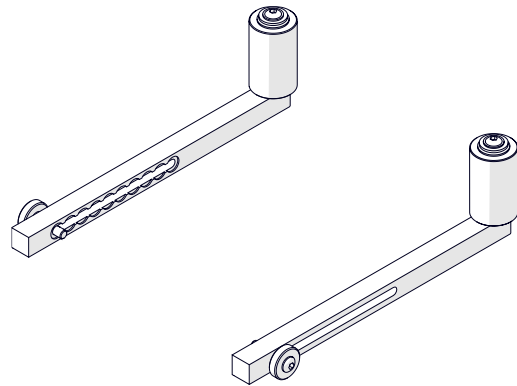
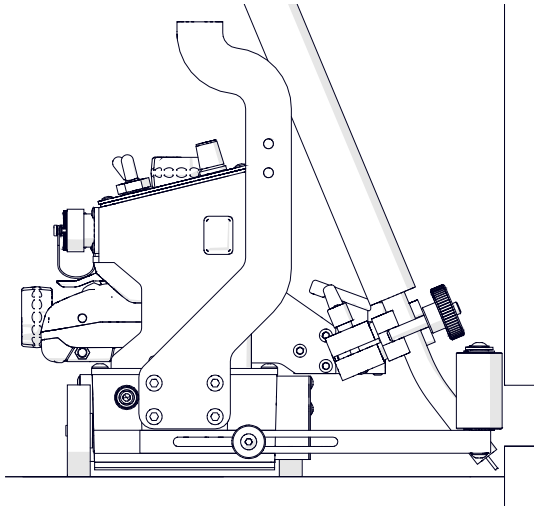

Part number (2 units):
PRW-0752-13-00-00-1

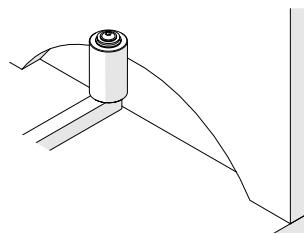

5.1. Pendulum oscillator

Allows pendulum oscillation of MIG/MAG torches.

The operation and installation is described in the separate manual.

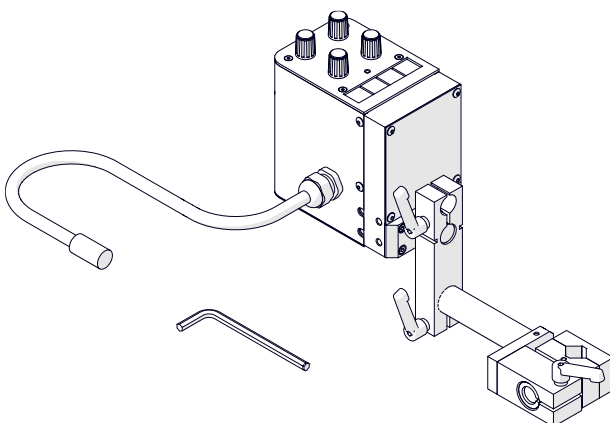

Part number (oscillator):
OSC-0799-01-00-00-0

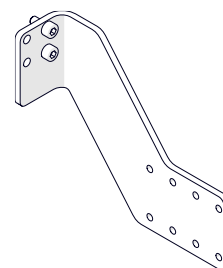

Part number (oscillator support):
WSP-0757-11-00-00-0
(including two M6x14 screws)

5.2. 76 mm cross slide

Increases the up-down or left-right adjustment range from 0–35 mm (0–1 3/8") to 0–76 mm (0–2 63/64").

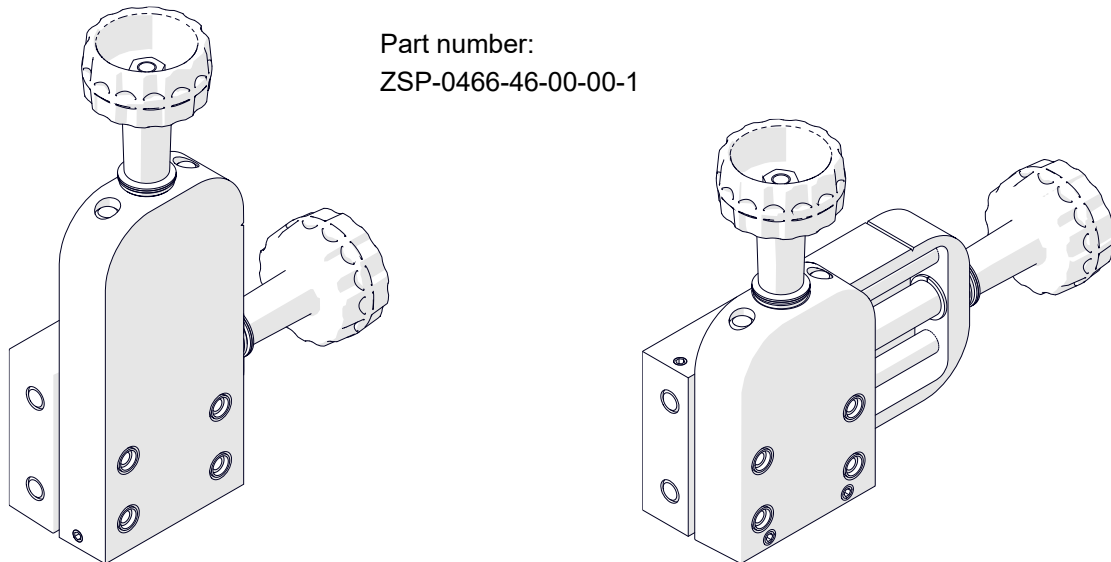

Install in place of the standard cross slide after removing four screws with a 3 mm hex wrench. Install with the same screws.

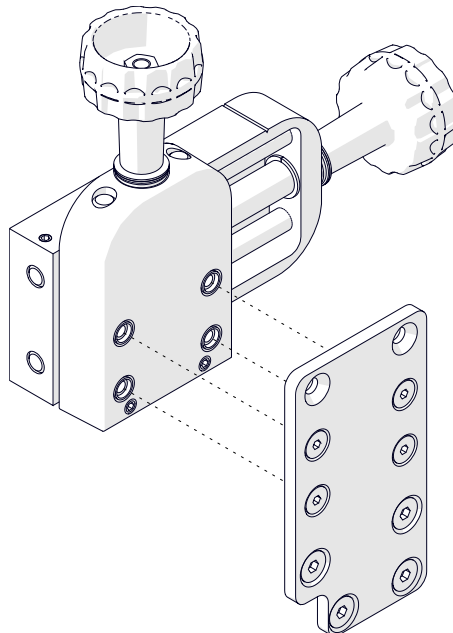

5.1. Cable anchor

Attaches the gas hoses and the power cable to decrease the load applied on the torch holder.

Using a 5 mm hex wrench and 10 mm flat wrench install the anchor on the carrying handle with two M6x45 screws and washers.

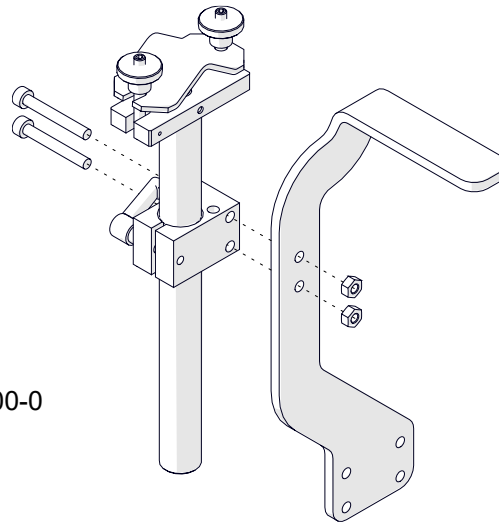

Part number:
PDT-0776-04-00-00-0

5.2. Torch extension arm

Increases the reach of the torch.

Use the 3 mm hex wrench to remove the screws that attach the cross slide. Use the same screws to attach the arm to the carriage. Using a 4 mm hex wrench, install the cross slide at the end of the arm with the included screws.

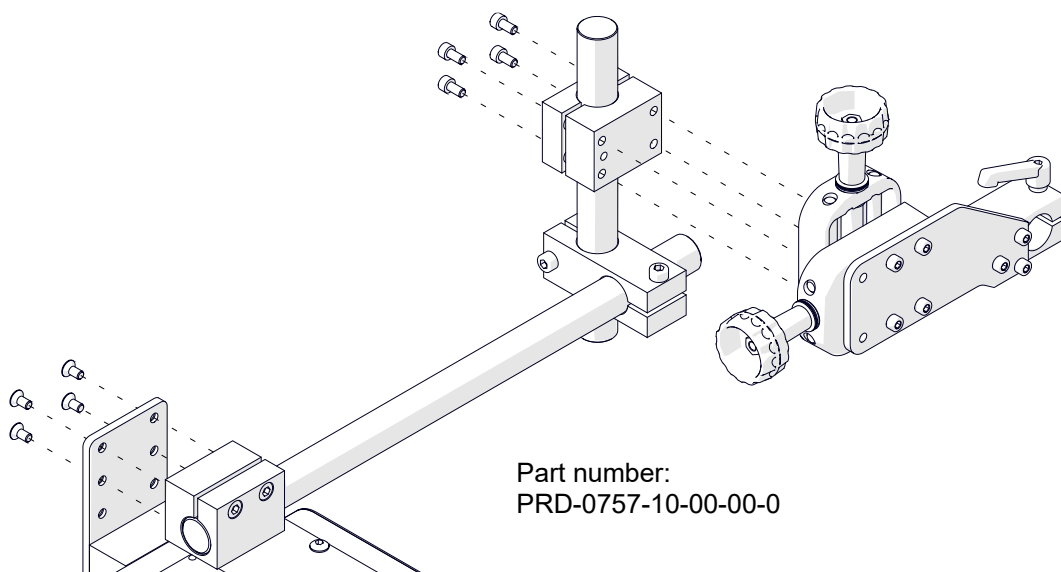

Part number:
PRD-0757-10-00-00-0

5.3. Dual torch mount

Allows using a second torch.

Use the 5 mm hex wrench to remove the screws that attach the carrying handle. Next, use the same screws to attach the mount to the carriage.

Part number:
PDT-0466-40-00-00-0

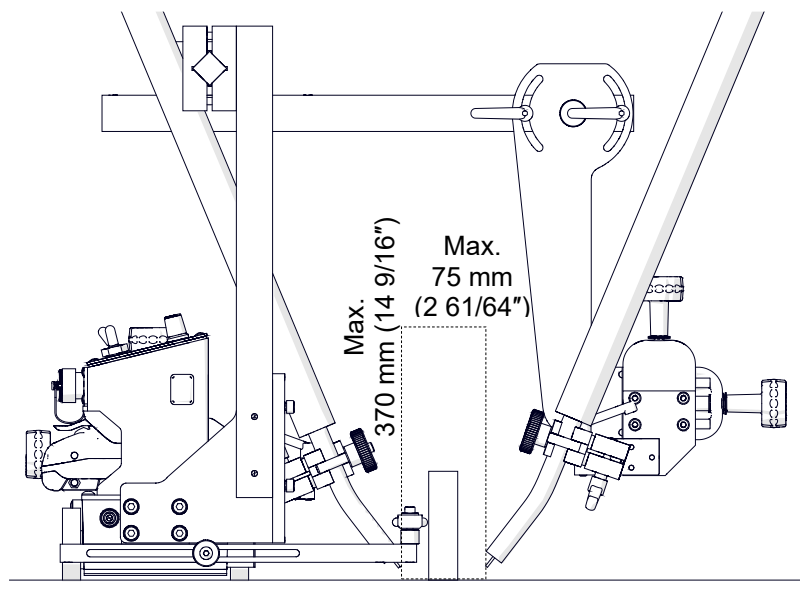
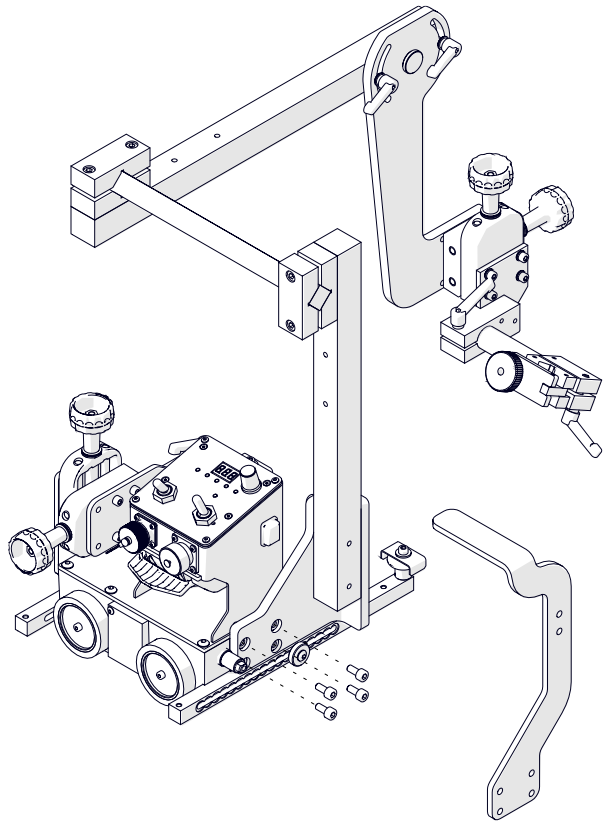

5.4. Flexible guide set

Allows guiding the carriage on planes along a straight line, and on pipes and tanks. A single flexible guide is 1.85 m (6 ft) long. Its minimum curve radius is 1 m (3.3 ft). The adjustment range of the guides is 170 mm (6 11/16").

| Holding force on a 5 mm (13/64") thick surface | Temperature | |
|--|-------------|---------|
| 100% (90 N) | 20°C | (68°F) |
| 75% (68 N) | 80°C | (176°F) |
| 50% (45 N) | 120°C | (248°F) |

Connect two guides with the 3 mm hex wrench and M5x16 screws to form a butt or lap joint. Next, use the 4 mm hex wrench to remove the standard guide arms and install the new guide arms.

Flexible guide (1 unit):
PRW-0466-50-01-01-0

Butt joint

Lap joint

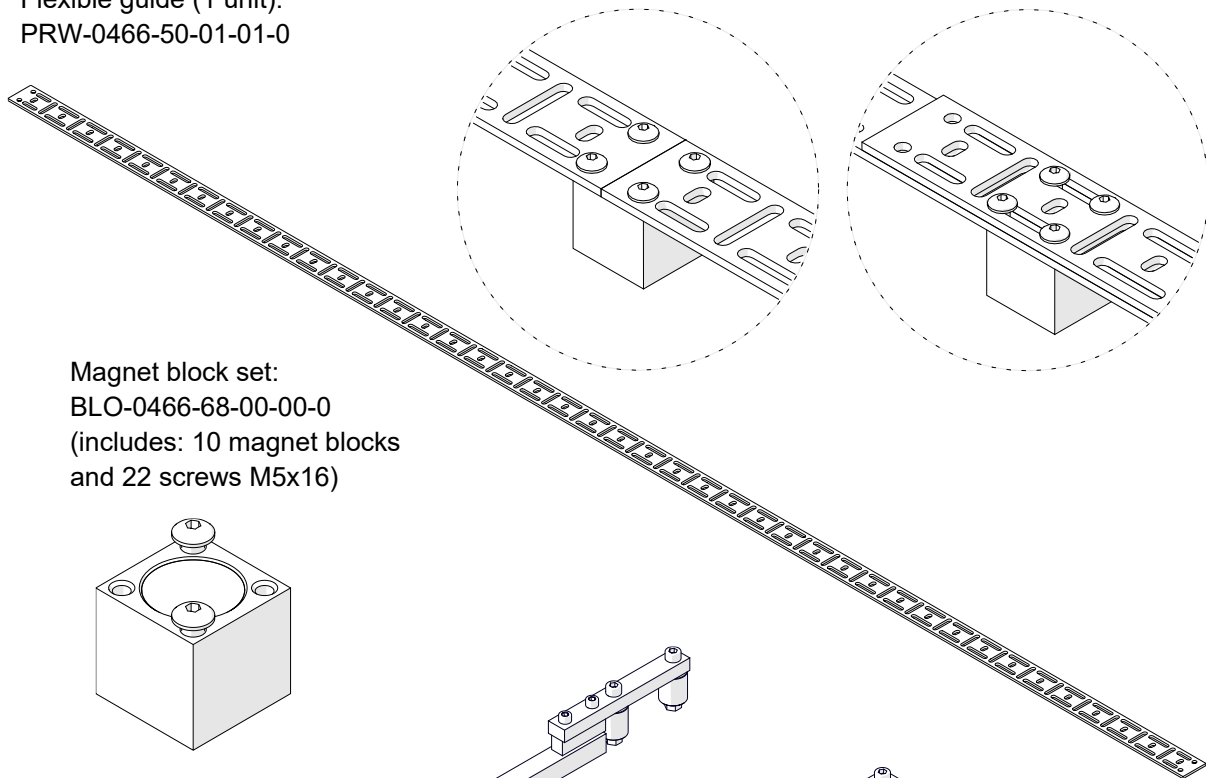

Magnet block set:
BLO-0466-68-00-00-0
(includes: 10 magnet blocks
and 22 screws M5x16)

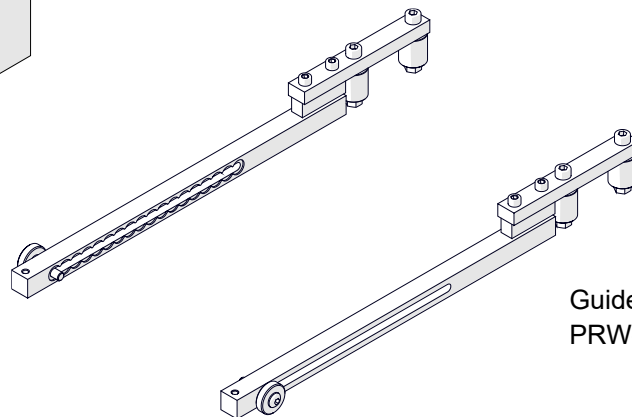
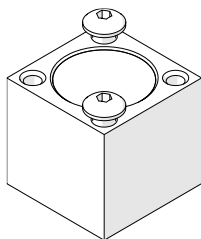

Guide arms (2 units):
PRW-0752-14-00-00-1

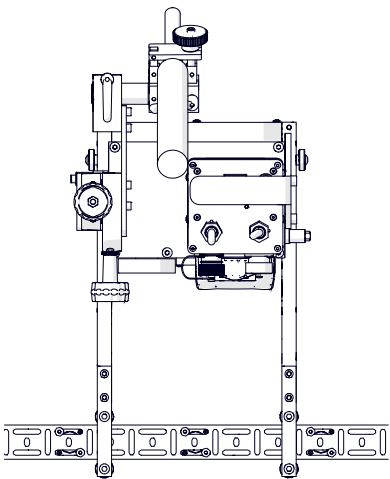
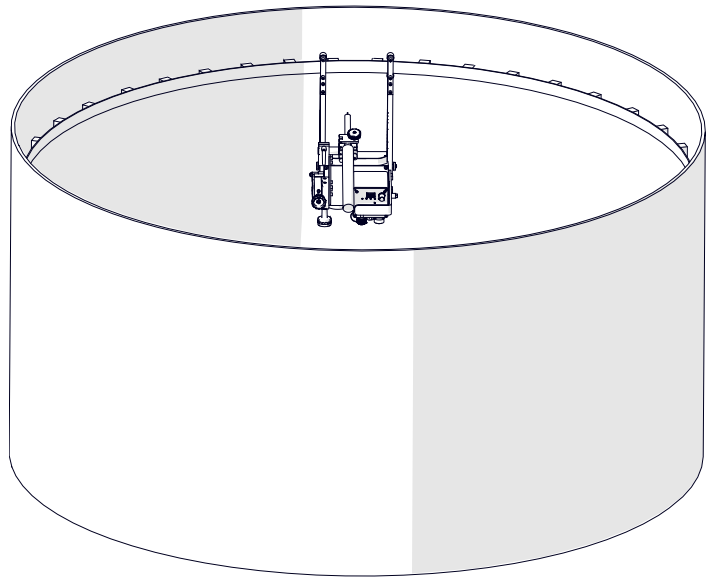
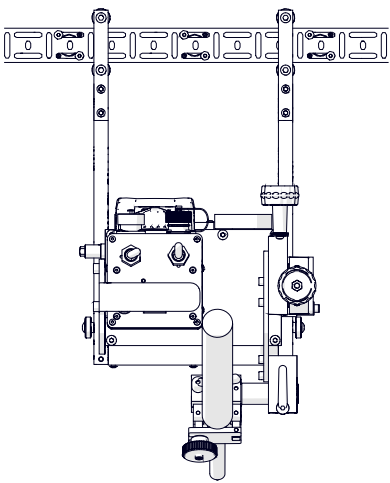
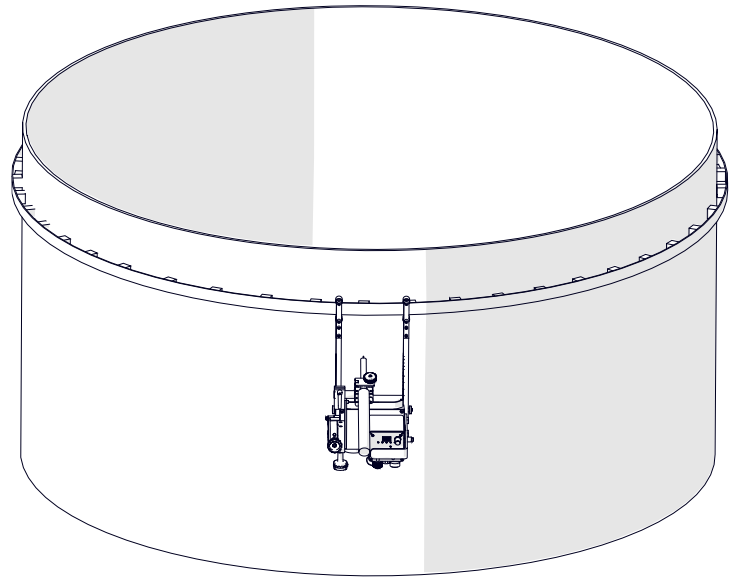
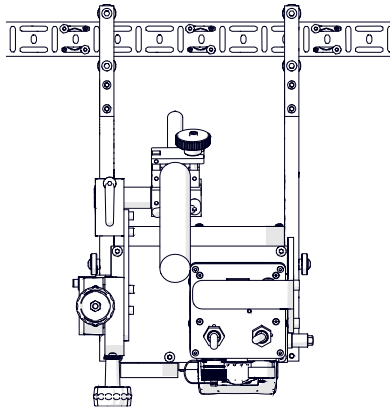

5.5. Guide adjustment tool

Allows the guide to be put parallel to an outside edge or a groove.

Part number:
UST-0466-53-00-00-0

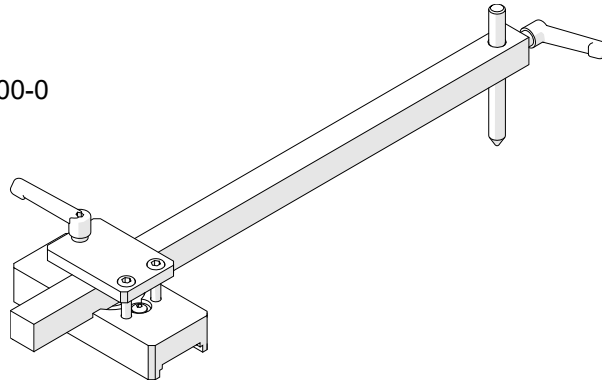

Attach the magnets to the guide, and put the guide on the workpiece along the direction of welding. Loosen the levers and put the tool onto the first magnet, resting the side of the pilot pin on an outside edge or putting the tip of the pilot pin in a groove. Then, lock the levers in this position and pull the further part of the guide off the workpiece (1). Next, start moving the tool along the guide (2) to clamp the successive magnets to the workpiece.

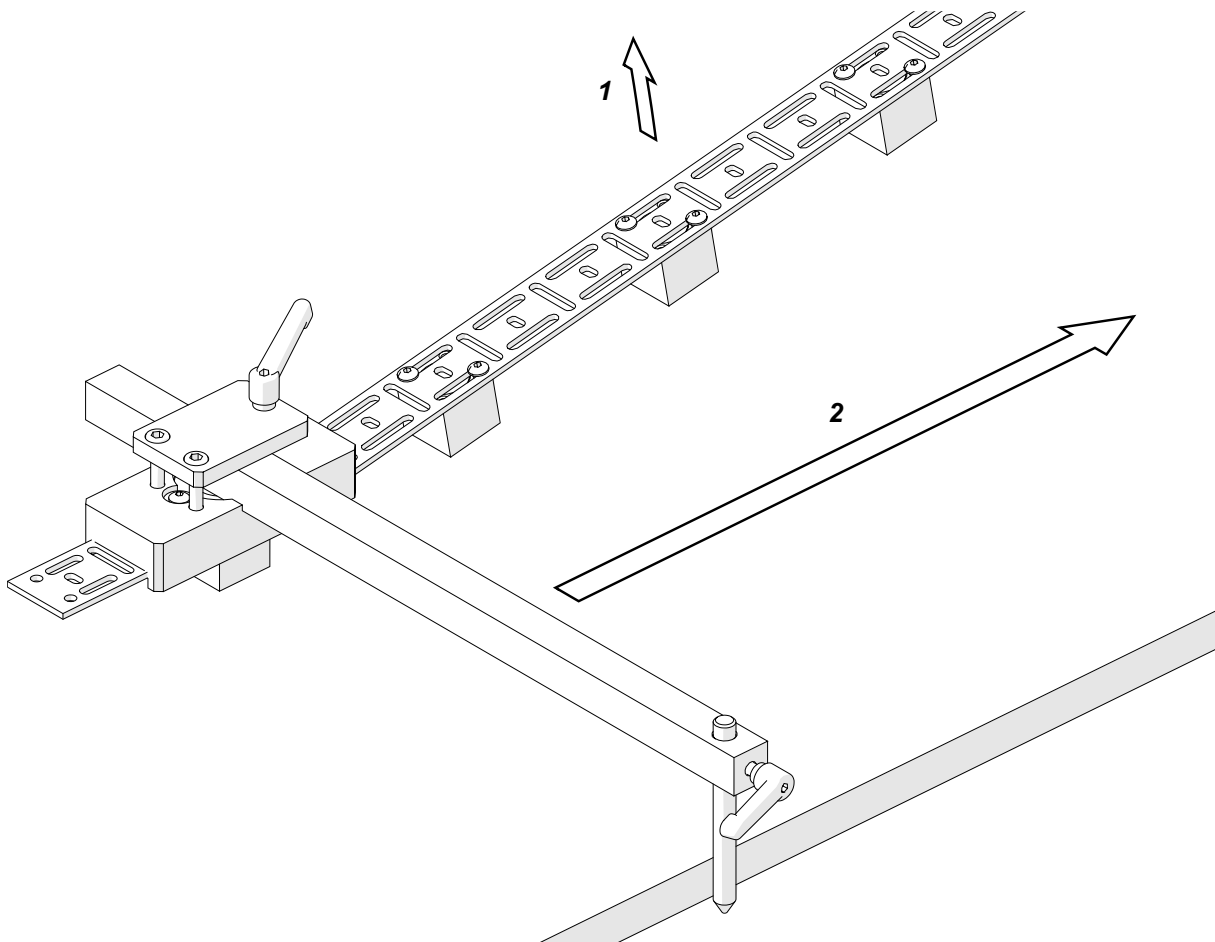

5.6. Flexible trackway set

Allows the carriage to move on flexible rails that are clamped to planes, pipes, or tanks. A single flexible rail is 1.88 m (6.1 ft) long, and its minimum curve radius is 1.25 m (4.1 ft).

Clamp each rail to the surface by using nine narrow magnetic units or at least five magnetic/vacuum units.

Before use, remove the anti-corrosion material from the rail.

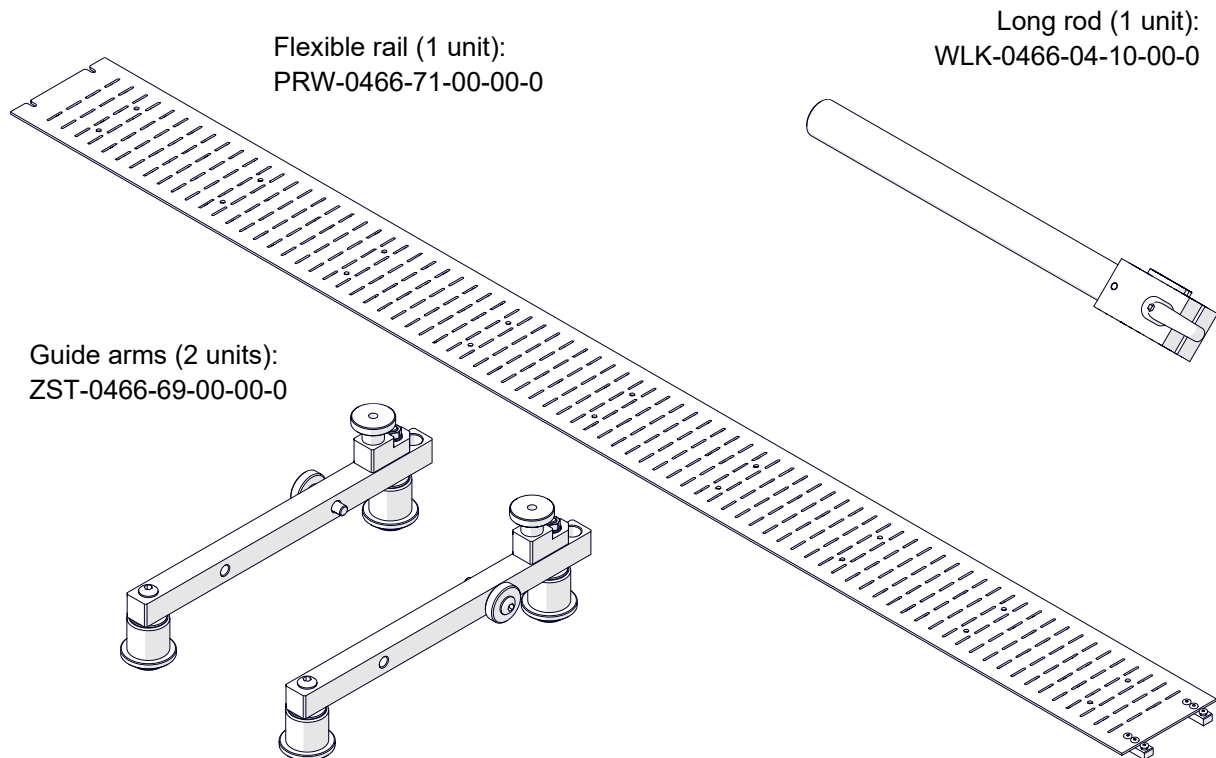

Connect two rails with the 3 mm hex wrench (1, 2). Use the 4 mm hex wrench to remove the standard guide arms and install the guide arms of the set with the included screws (3). Remove the sleeve from the long rod (4) and install the rod into the carriage. Next, install the torch holder into the rod (5) and move the rollers outward (6, 7, 8). Then, put the carriage onto the rail and set the rollers as before.

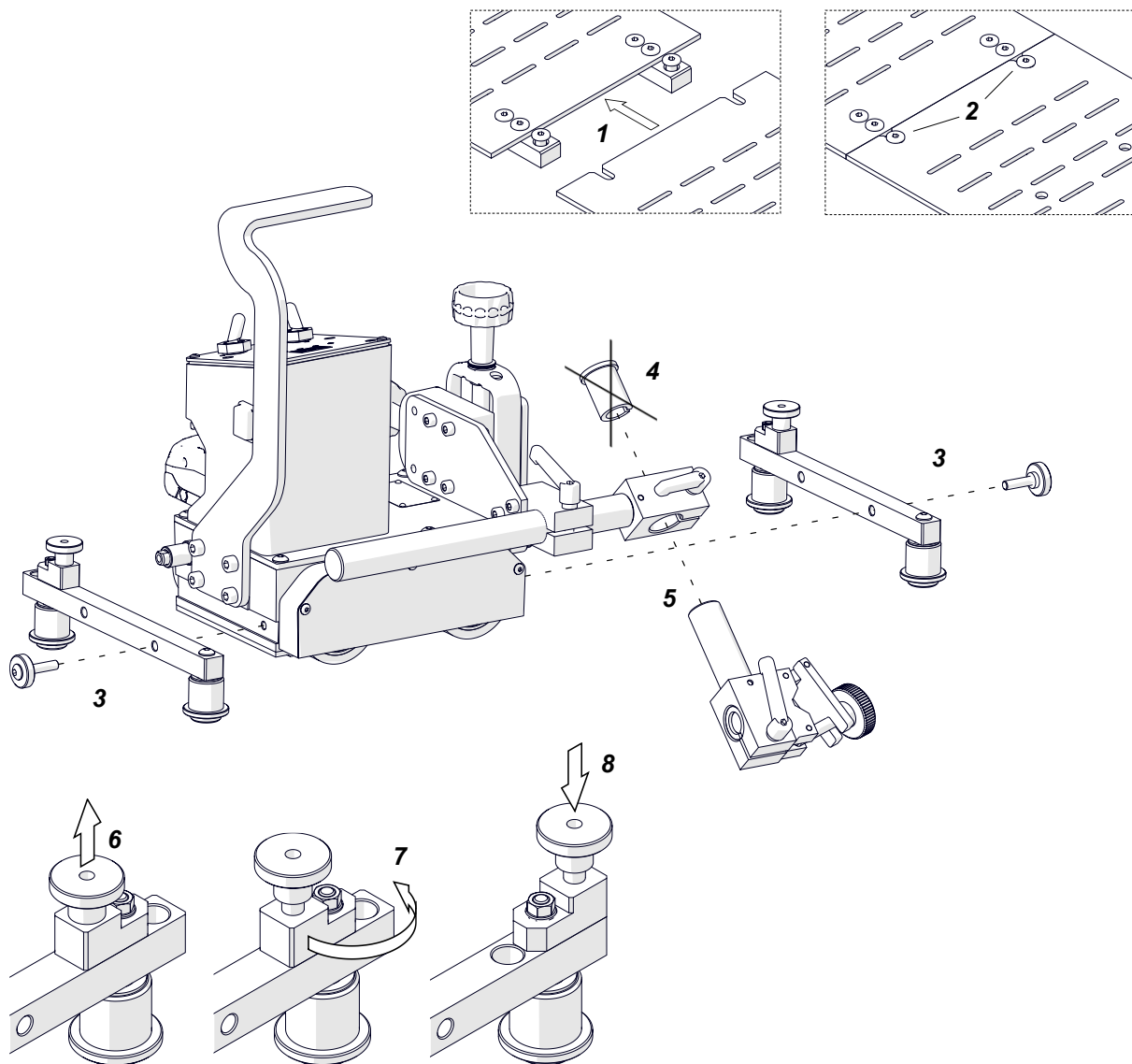

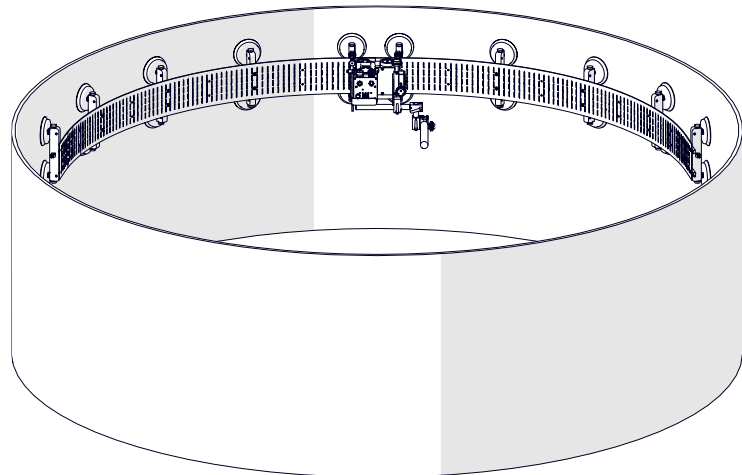
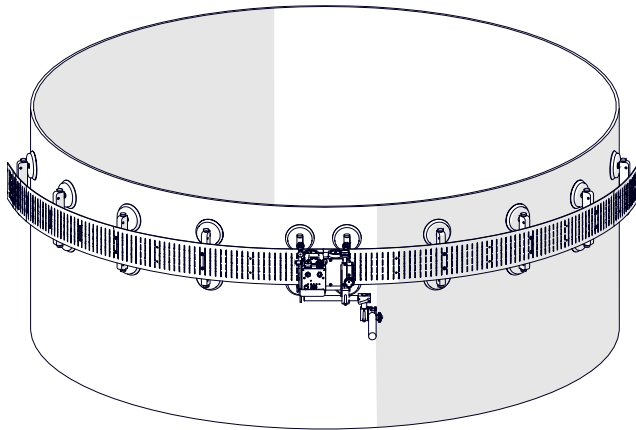
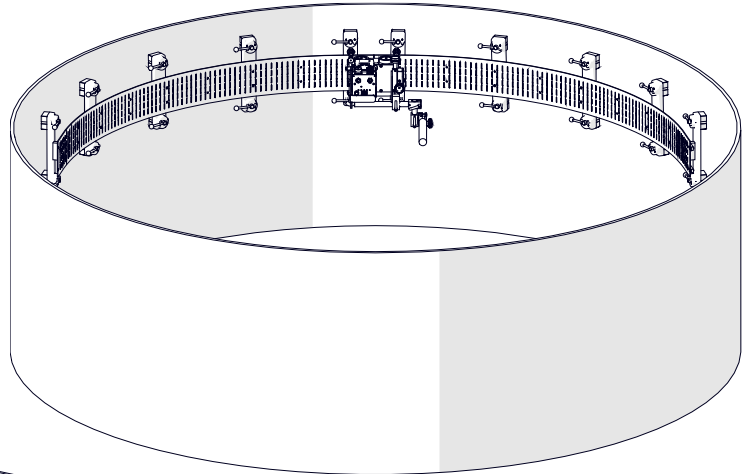
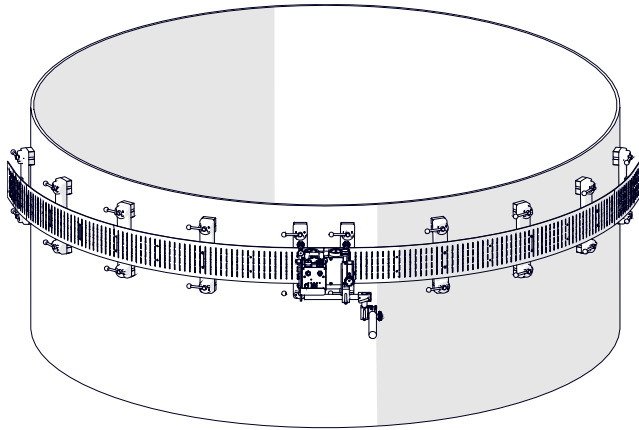

5.7. Magnetic units for flexible trackway

5.7.1. Magnetic unit

Allows clamping a flexible trackway to ferromagnetic surfaces.

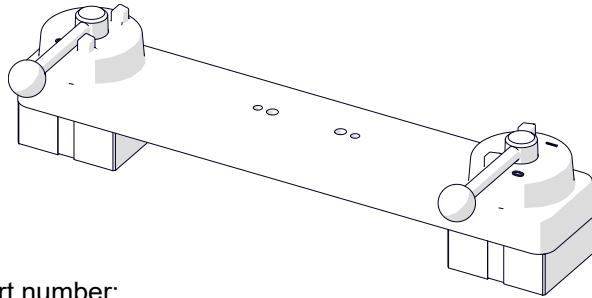

Part number:
 ZSP-0475-92-00-00-0 (magnetic unit)
 ZSP-0475-93-00-00-0 (heat-resistant magnetic unit)

Part number (bracket):
 DYS-0466-71-05-00-0

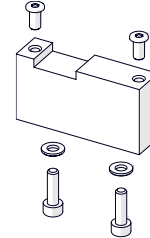

| Holding force on a 5 mm (13/64") thick surface | Temperature | |
|---|---------------|---------------|
| | Magnetic unit | |
| 100% (1200 N) | 20°C (68°F) | 80°C (176°F) |
| 75% (900 N) | 80°C (176°F) | 160°C (320°F) |
| 50% (600 N) | 120°C (248°F) | 200°C (392°F) |

Install with a 5 mm hex wrench (not included) and a torx screwdriver (not included).

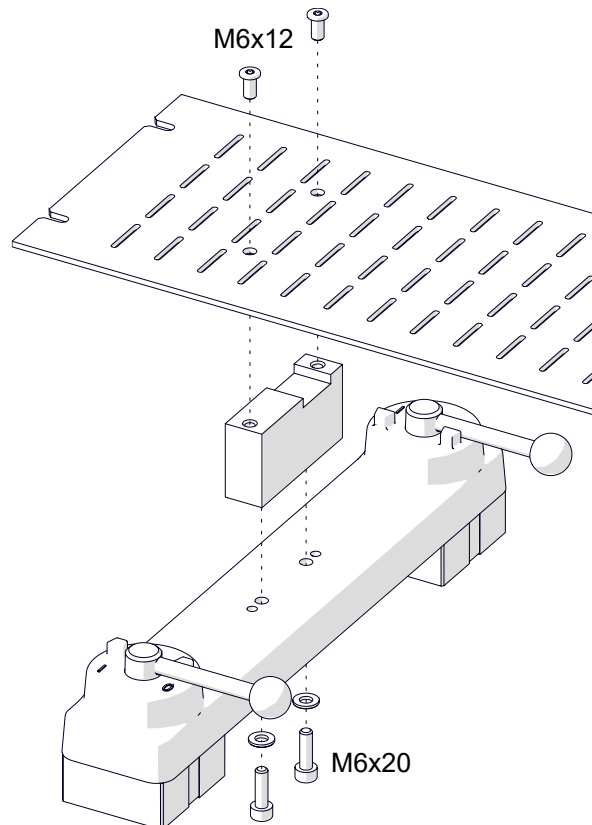

5.7.2. Pivoting magnetic unit

Allows clamping a flexible trackway to ferromagnetic surfaces that are concave or convex, to pipes with outer diameters of at least 800 mm (31 1/2"), and to surfaces that differ in height up to 80 mm (3 5/32").

Part number:
ZSP-0475-85-00-00

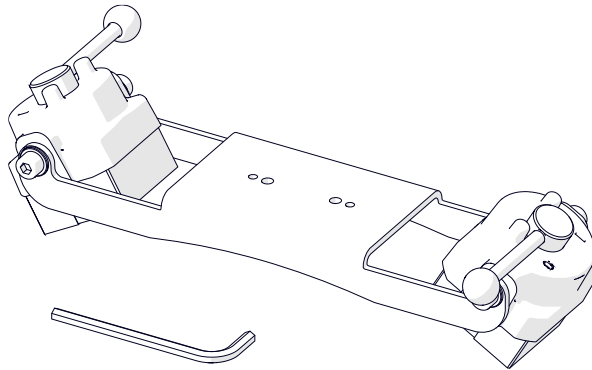

Part number (bracket):
DYS-0466-71-05-00-0

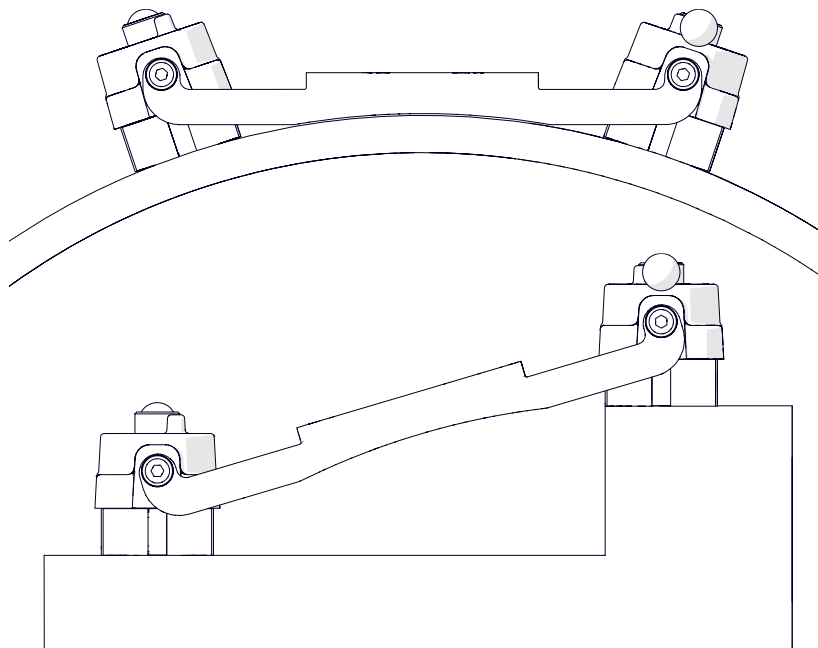
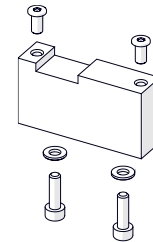

| Holding force on a 5 mm (13/64") thick surface | Temperature | |
|--|---------------|---------|
| | 100% (1200 N) | 20°C |
| 75% (900 N) | 80°C | (176°F) |
| 50% (600 N) | 120°C | (248°F) |

Install the unit in the same way as the magnetic unit is installed. To adjust the angle, use the 6 mm hex wrench and loosen four side screws.

5.7.3. Spacing-adjustable magnetic unit

Allows clamping a flexible trackway to two ferromagnetic pipes with diameters of 25–230 mm (63/64–9 1/16") and with distance between pipe axes of 170–230 mm (6 11/16–9 1/16").

Part number:
ZSP-0523-19-00-00-0

Part number (bracket):
DYS-0466-71-05-00-0

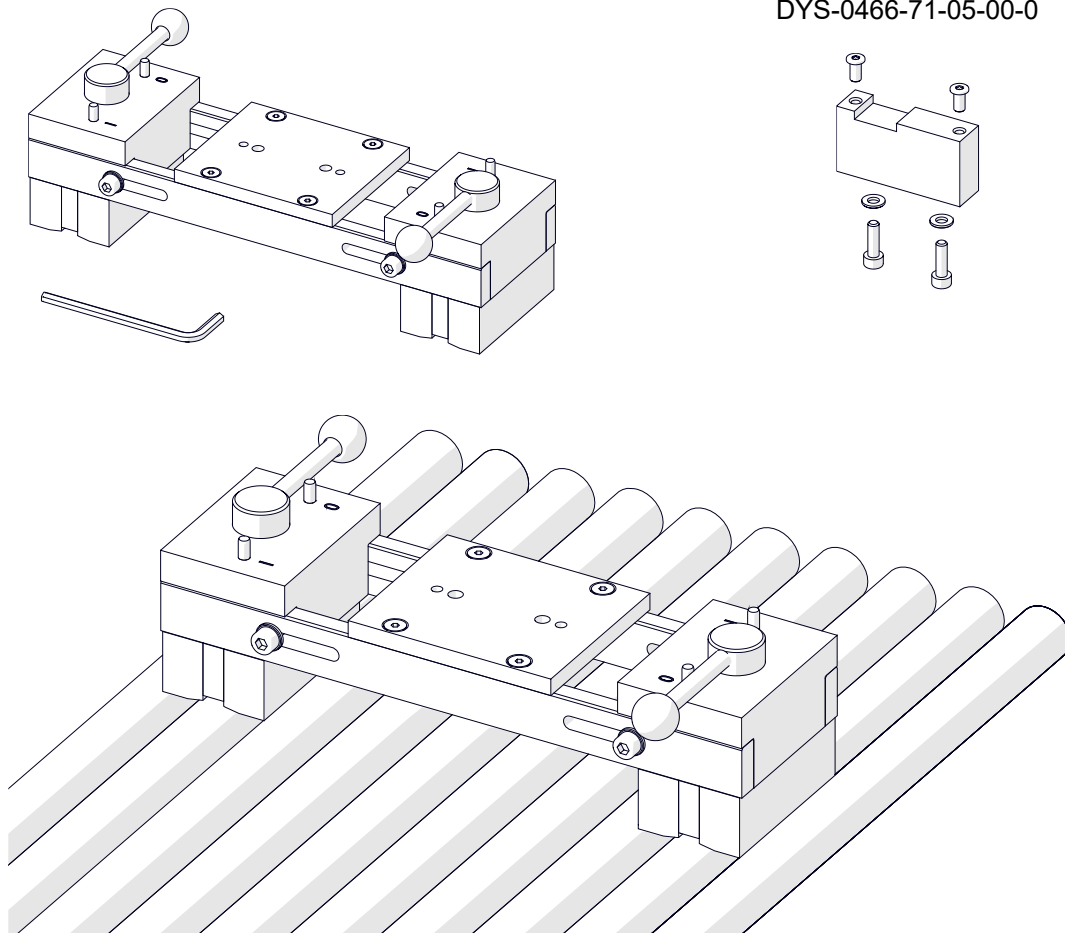

| Holding force on a 5 mm (13/64") thick surface | Temperature | |
|--|---------------|---------|
| | 100% (1200 N) | 20°C |
| 75% (900 N) | 80°C | (176°F) |
| 50% (600 N) | 120°C | (248°F) |

Install the unit in the same way as the magnetic unit is installed. To adjust the space, use the 5 mm hex wrench and loosen four side screws.

5.7.4. Narrow magnetic unit

Allows clamping a flexible trackway to ferromagnetic surfaces.

Part number:
PDS-0582-10-00-02-0

Part number (bracket):
DYS-0466-71-07-00-0

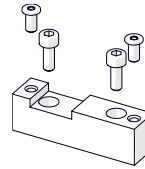
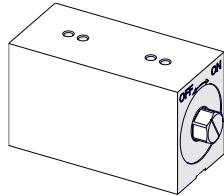

| Holding force on a 5 mm (13/64") thick surface | Temperature | |
|--|---------------|---------|
| | 100% (1000 N) | 20°C |
| 75% (750 N) | 80°C | (176°F) |
| 50% (500 N) | 120°C | (248°F) |

Install with a 5 mm hex wrench (not included) and a torx screwdriver (not included).

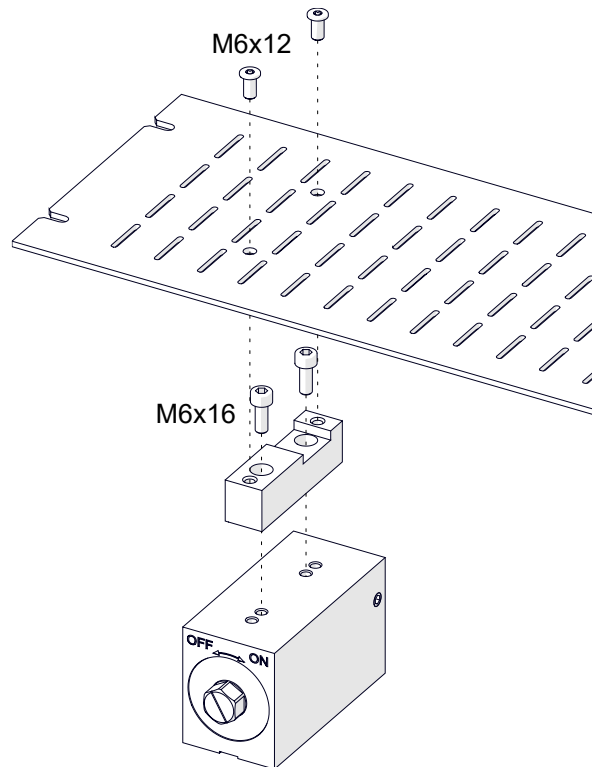

To clamp the unit to the surface, use the 17 mm flat wrench (not included) and set the side screw to ON.

5.8. Support for flexible trackway with magnetic units

Allows supporting a flexible trackway used with at least five magnetic units, by filling the gaps between the units. Install with a torx screwdriver (not included) and M6x12 screws.

Part number:
WSP-0466-71-06-00-0

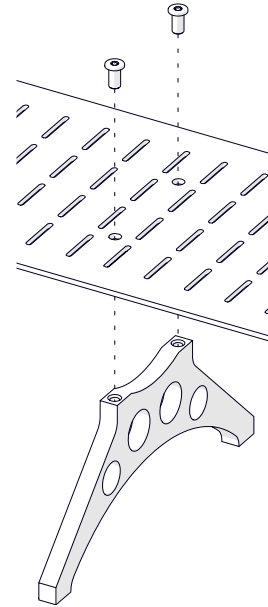
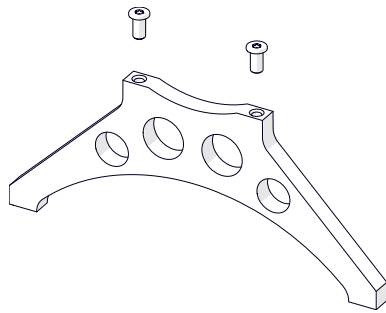

5.9. Vacuum unit

When used with a vacuum pump, the vacuum unit allows clamping a flexible trackway to non-ferromagnetic surfaces. The holding force of the vacuum unit is 1400 N at gauge pressure of -0.7 bar (-10 psig) and atmospheric pressure at sea level. The force decreases with increase in height above sea level. To increase the holding force of the trackway, use more vacuum units.

Make sure that the ambient temperature is between -20°C (-4°F) and 200°C (392°F). Keep the flame at least 100 mm ($3\ 15/16$ ") away from the vacuum pads.

Part number:
MST-0541-10-02-00-0

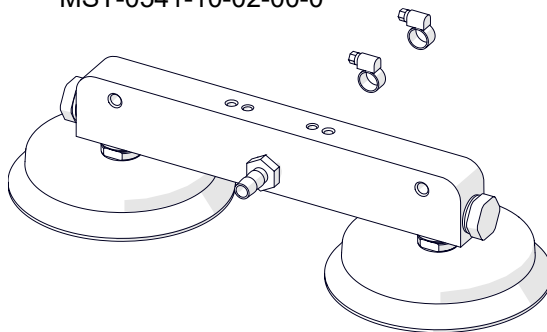

Part number (bracket):
DYS-0466-71-04-00-0

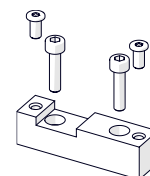

Install with a 4 mm hex wrench and 5 mm hex wrench (not included).

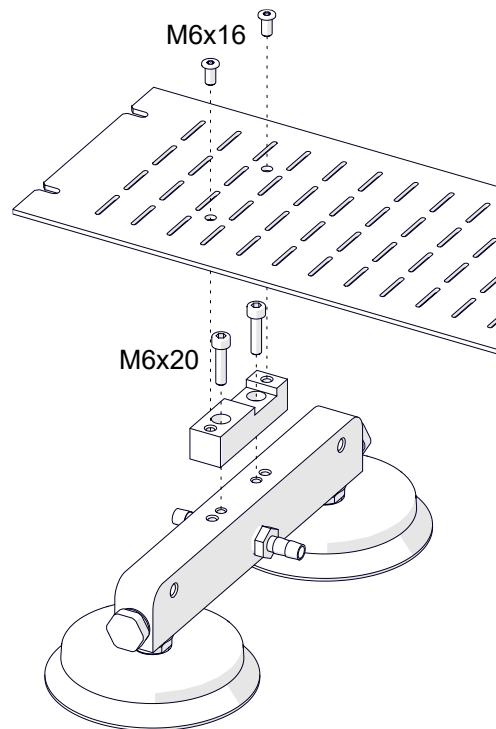

5.10. Support for flexible trackway with vacuum units

Allows supporting a flexible trackway used with at least five vacuum units, by filling the gaps between the units. Install with a torx screwdriver (not included) and the M6x12 screws.

Part number:
WSP-0466-71-03-00-0

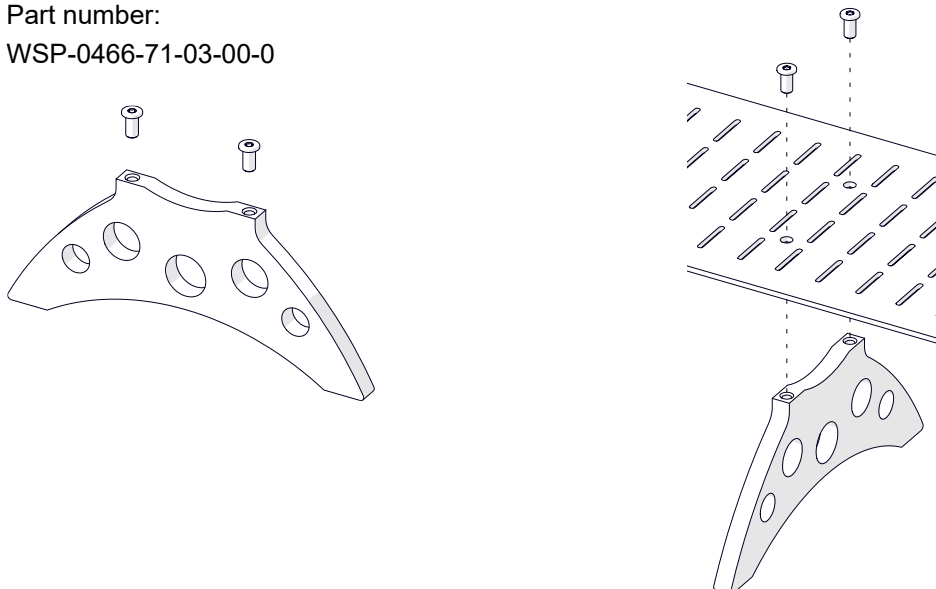

5.11. Vacuum Track System

Allows clamping a flexible trackway to non-ferromagnetic surfaces.

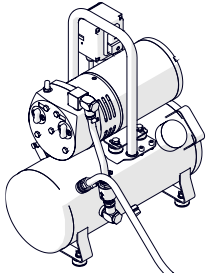

Part number (vacuum pump with safety reservoir):

AGR-0541-10-20-00-0 (EU)

AGR-0541-10-10-00-0 (UK)

Other parts of the system are described in a separate manual.

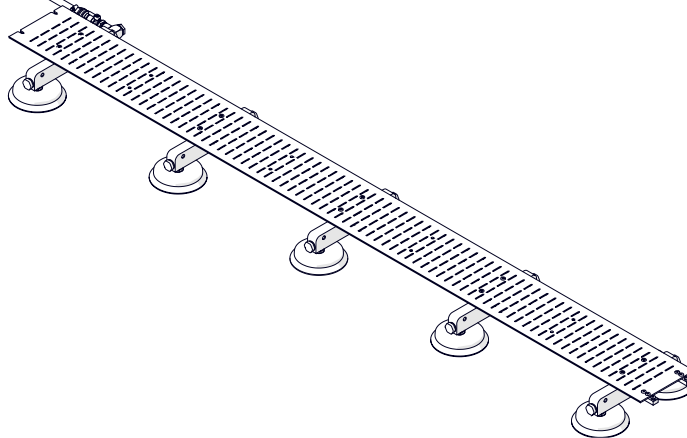

5.12. Stainless steel wheels

Allow working in horizontal position on a preheated plate.

Part number (1 unit):

KOL-0466-72-00-00-0

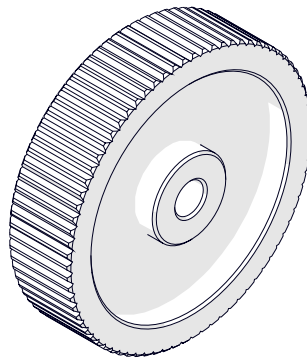

Use the 2.5 mm hex wrench (not included) to remove the cover. Next, remove four wheels using a 3 mm hex wrench. Install in reverse sequence.

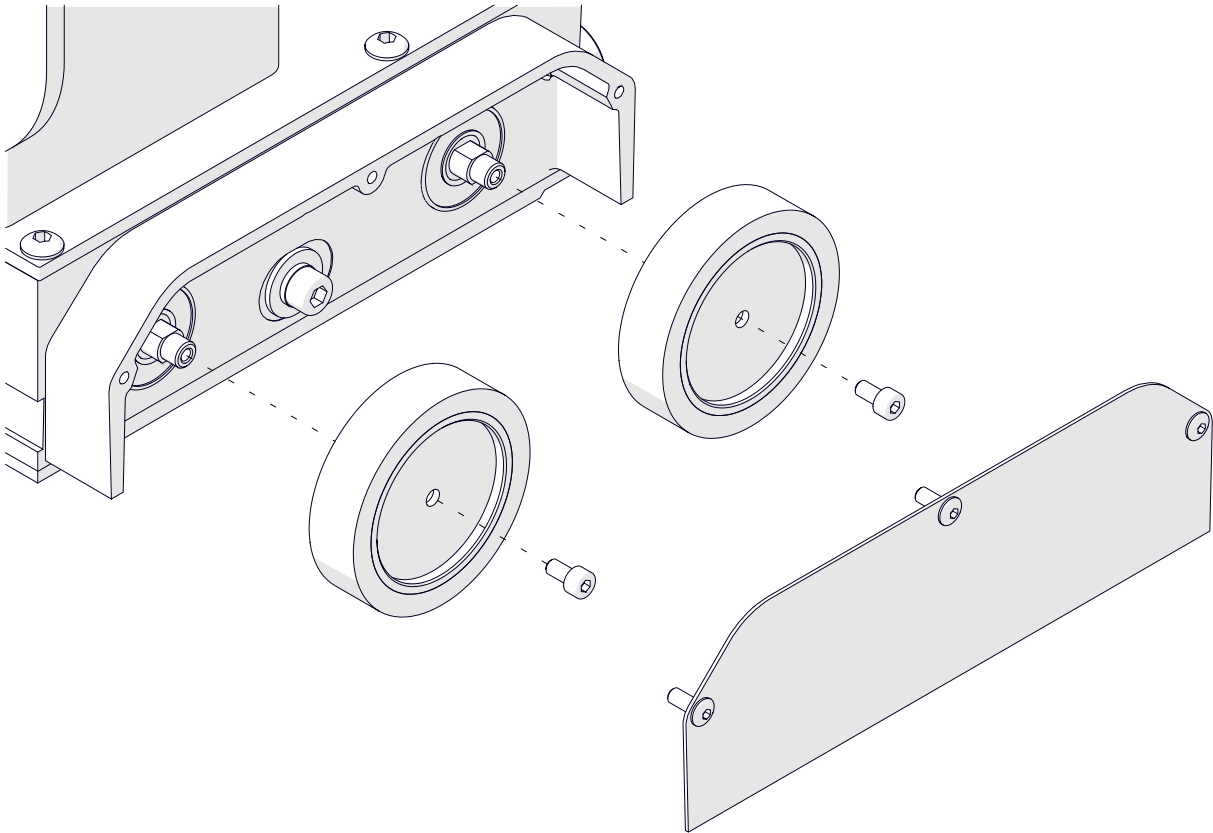

5.13. Battery 4 Ah

Power source required for machine operation.

Part number:
AKM-0738-10-00-01-0

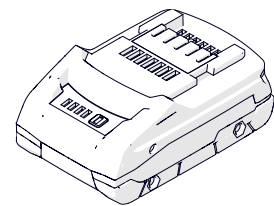

5.14. Charger

Charges the battery from the power source.

Part number:
LDW-0738-04-00-30-0 (UK)
LDW-0738-06-00-30-0 (AUS/NZ)
LDW-0738-10-00-30-0 (EU)
LDW-0738-24-00-30-0 (USA/CND)

