

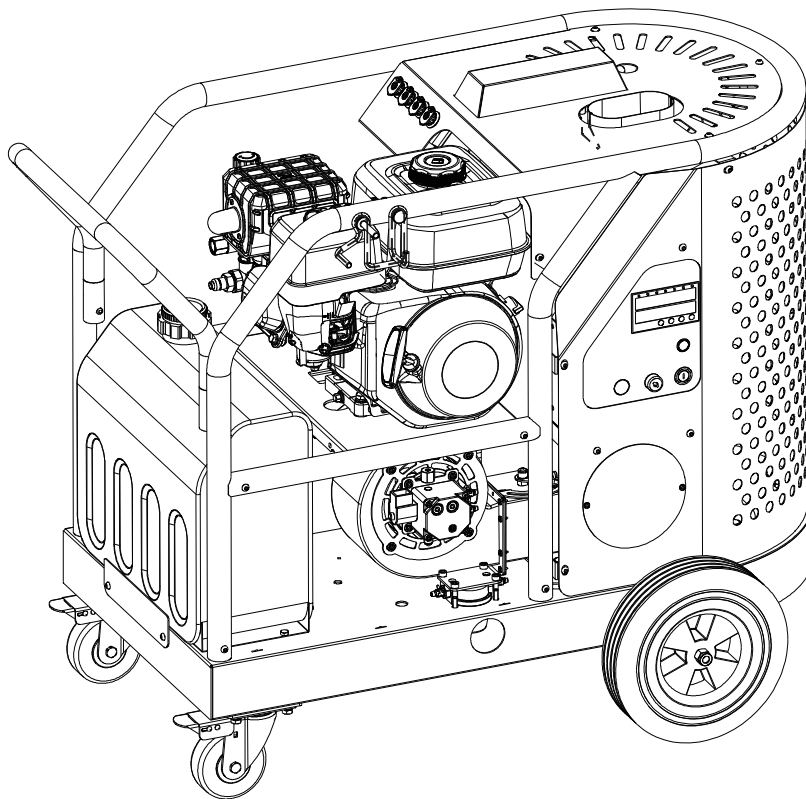

HOT WATER PRESSURE WASHER

Commercial Gas & Powered by Honda Hot Water Pressure Washer

OPERATOR'S MANUAL



Part No: TM545-3600H

Ver: 1.0



TO PREVENT SERIOUS INJURY OR DAMAGE TO YOUR PRESSURE WASHER,
READ AND UNDERSTAND ALL WARNINGS AND INSTRUCTIONS BEFORE USE



Contents

1. Introduction	2
2. Products Specifications	3
3. Products Identification	4
4. Safety Guidelines	4, 5, 6, 7
5. Parts Identification and Features	8, 9, 10, 11
6. Safe Working Environment	12
7. Gas Engine Preparing Before Use	13
8. Diesel Engine Preparing Before Use	14
9. Setting Up Before Use	15, 16
10. Startup and Stopping Procedure-Gas Engine	17, 18
11. Startup and Stopping Procedure-Diesel Engine	18
12. Burn Operation	19
13. Using Nozzles	20
14. Adjusting Spray Pressure	21
15. Using Chemicals & Detergents	21
16. Maintenance	22, 23
17. Storage	24
18. Troubleshooting	25, 26, 27
19. Circuit Diagram	28

Disclaimer:

The information in this document is to the best of our knowledge true and accurate, but all recommendations or suggestions are made without guarantee. Since the conditions of use are beyond their control, the factory disclaim any liability for loss or damage suffered from the use of this data or suggestions. Furthermore, no liability is accepted if use of any product in accordance with this data or suggestions infringes any patent. The factory reserve the right to change product specifications and warranty statements without further notification. All images are for illustration purposes only.















1. Introduction

Thank you for purchasing this **Professional Power Equipment Product**.

Please read the following instructions carefully to help to ensure your personal safety and the correct assembly, use and maintenance of this equipment. Please ensure that you have read and understand the information contained in the manual before attempting to use the equipment. This equipment should only be used by trained and fully competent individuals, in a safe working environment. Please ensure that the appropriate safety equipment is worn at all times and that the product is not adapted or modified in anyway.

Please note that the contents of this instruction manual are based on the latest product information available at the time of publication and that the manufacturer reserves the right to make changes at any time without notice.

2. Products Specifications

Model		TM545-3600H
Max Pressure		3620psi/250bar
Max Flow		15L/min
Pump Model		Direct Drive with gearbox reduction
Power And Type		13HP/390cc OHV
Start Type		Electric Start
Battery		36A/H
Gun And Lance		Hot water Trigger gun
High Pressure Hose		ID 8*15m, hot water steel braided
Nozzle		5tips, QD nozzle
Burner Fuel Tank		33 Liter
Fuel Consumption		12.6L/h
Heating Coil		Vertical, top fried, dual coil
Shipping Size		122x92x120cm
Shipping Weight		220kgs

3. Products Identification

RECORD IDENTIFICATION NUMBERS

If you need to contact an Authorized Dealer for information on servicing, always provide the product model and identification numbers. You will need to locate the model, revision and serial number for the machine and record the information in the places provided below. You will also need the model and serial number for the engine on your machine.

1. Date of Purchase: _____
2. Dealer Name: _____
3. Dealer Phone: _____
4. Unit Model Name: _____
6. Pump Model & Serial Number: _____
5. Engine Model & Serial Number: _____

NOTE: Check the article 5.1 (page 7) for the location of the pump model & serial no. on the pump. Check the engine operators manual for the location of these numbers.

4. Safety Guidelines



WARNING- READ AND FOLLOW ALL INSTRUCTIONS

- Failure to follow all instructions in this manual may result in severe personal injury or death. Keep this manual and refer to it for Safety Instructions, Operating Procedures, and Warranty.



This manual contains information that is important for you to know and understand. This information relates to protecting **YOUR SAFETY** and **PREVENTING EQUIPMENT PROBLEMS**. To help you recognize this information, we use the symbols below. Please read the manual and pay attention to these sections.



DANGER

DANGER indicates an imminently hazardous situation which, if not avoided, will result in death or serious injury.



CAUTION

CAUTION indicates a potentially hazardous situation which, if not avoided, may result in minor or moderate injury.



WARNING

WARNING indicates a potentially hazardous situation which, if not avoided, could result in death or serious injury.



CAUTION

CAUTION used without the safety alert symbol indicates a potentially hazardous situation which, if not avoided, may result in property damage.

Improper maintenance and operation are responsible for the majority of accidents involving gas pressure washers. The largest portion of these could be prevented by recognizing the basic safety rules and precautions. Most accidents can be avoided if the operator recognizes a potentially hazardous situation before it happens and by observing appropriate safety rules and procedures as outlined in this manual. Basic safety precautions are outlined in the **SAFETY** portion of this manual and throughout the text in this manual where a potential hazard might occur. Hazards that **MUST** be avoided to prevent serious injury follow headers marked **DANGER** or **WARNING**. These same precautions are placed as labels on the tool itself. **NEVER** use this pressure washer for applications that are **NOT** specified in this manual.

3. Safety Guidelines (continued)



DANGER-- RISK TO BREATHING

- Running engine gives off carbon monoxide, an odorless, colorless, poison gas.
- Breathing carbon monoxide can cause nausea, fainting or death.
- Some chemicals or detergents may be harmful if inhaled or ingested, causing severe nausea, fainting or poisoning.



- **ALWAYS** Operate pressure washer in a well ventilated area. Avoid enclosed areas such as garages, basements, etc.
- **ALWAYS** Keep exhaust gas from entering a confined area through windows, doors, ventilation intakes, or other openings.
- **ALWAYS** follow manufacturers recommendations, use a respirator or mask whenever there is a chance that vapors may be inhaled.
- **ALWAYS** use the only fluids specifically recommended for high pressure washers.
- **NEVER** operate unit in a location occupied by humans or animals.
- **NEVER** use chlorine bleach or any other corrosive compound.



DANGER--RISK OF EXPLOSION OR FIRE

- Fuel and its vapors are extremely flammable and explosive.
- Fire or explosion can cause severe burns or death.



ALWAYS shut off engine and allow it to cool a least 2minutes before adding fuel to the tank.

ALWAYS use care in filling tank to avoid spilling fuel. Move pressure washer away from fueling area before starting engine.

ALWAYS Keep maximum fuel level below top of tank to allow for expansion.

ALWAYS operate and fuel equipment in well ventilated areas free from obstructions. Equip areas with fire extinguishers suitable for gasoline fires.

ALWAYS keep pressure washer a minimum of four feet away from surfaces (such as houses, automobiles, or live plants) that could be damaged from muffler exhaust heat.

ALWAYS Store fuel in an OSHA approved container, in a secure location away from work area.

NEVER spray flammable liquids

NEVER operate pressure washer in an area containing dry brush or weeds.



WARNING--RISK OF FALL HAZARD

- Use of pressure washer can create puddles and slippery surfaces.
- Kickback from spray gun can cause you to fall.



- Keep the area of operation clear of all persons, particularly small children, pets and obstacles.
- Do not operate the product when fatigued or under the influence of alcohol or drugs. Stay alert at all times.
- If engine does not start after two pulls, squeeze trigger of gun to relieve pump pressure. Pull starter cord slowly until resistance is felt. Then pull cord rapidly to avoid kickback and prevent hand or arm injury.
- Do not overreach or stand on an unstable support.
- The cleaning area should have adequate slopes and drainage to reduce the possibility of a fall due to slippery surfaces.
- Be extremely careful if you must use the pressure washer from a ladder, scaffolding, or any other similar location.
- Beware of kick-back force and the sudden torque on the spray gun assembly when operating the trigger. Firmly grasp spray gun with both hands to avoid injury when spray gun kicks back.

3. Safety Guidelines (continued)



WARNING--RISK TO FLUID INJECTION

- The high pressure stream of water that this equipment produces can cut through skin and its underlying tissues, leading to serious injury and possible amputation. Spray gun traps high water pressure, even when engine is stopped and water is disconnected, which can cause injury.

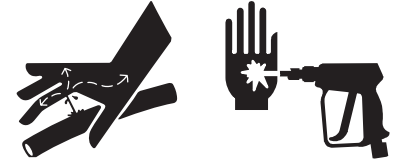

- **ALWAYS** point spray gun in safe direction and squeeze trigger, to release high pressure, every time you stop engine.
- **NEVER** place hands in front of nozzle.
- **MAKE SURE** hose and fittings are tightened and in good condition. Never hold onto the hose or fittings during operation.
- **DO NOT** allow hose to contact muffler.
- **NEVER** attach or remove wand or hose fittings while system is pressurized.
- **NEVER** use a spray gun which does not have a trigger lock or trigger guard in place and in working order.
- **ONLY USE** hose and high pressure accessories rated for pressure higher than your pressure washer's p.s.i.
To relieve system pressure, shut off engine, turn off water supply, and pull gun trigger until water stops flowing.
- **DO NOT** allow **CHILDREN** to operate pressure washer.
- **NEVER** repair leaking connections with sealant of any kind. Replace o-ring or seal.
- **NEVER** connect high pressure hose to nozzle extension.
- **DO NOT** secure spray gun in open position.
- **DO NOT** leave spray gun unattended while machine is running.
- **ALWAYS** be certain spray gun, nozzles and accessories are correctly attached.
- **NEVER** aim spray gun at people, animals, or any electrical device and the machine itself.

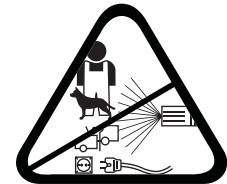

DANGER-- RISK OF CHEMICAL BURN

- Use of acids, toxic or corrosive chemicals, poisons, insecticides, or any kind of flammable solvent with this product could result in serious injury or death.



- **DO NOT** use acids, gasoline, kerosene, or any other flammable materials in this product. Use only household detergents, cleaners and degreasers recommended for use in pressure washers.
- Wear protective clothing to protect eyes and skin from contact with sprayed materials.
- **DO NOT** use chlorine bleach or any other corrosive compound



WARNING--RISK OF ELECTRICAL SHOCK

- Risk of electrocution.
- Contact with power source can cause electric shock or burn.



- Unplug any electrically operated product before attempting to clean it.
- Direct spray away from electric outlets and switches.
- **NEVER** spray near power source.
- **DO NOT** touch the plug with wet hands.
- **WHEN SERVICING THE PRESSURE WASHER:** Disconnect the spark plug wire and place it where it cannot contact the plug. **DO NOT** check for spark with the plug removed. Use only approved spark plug testers.

3. Safety Guidelines (continued)



DANGER-- RISK OF HOT SURFACES

- Contact with hot surfaces, such as engines exhaust components, could result in serious burn.



- During operation, touch only the control surfaces of the pressure washer.
- Keep children away from the pressure washer at all times. They may not be able to recognize the hazards of this product.
- **DO NOT** let hoses come in contact with very hot engine muffler during or immediately after use of your pressure washer.
- **AVOID** hot exhaust gases.



DANGER-- RISK OF MOVING PARTS

- Starter and other rotating parts can entangle hands, hair, clothing, or accessories.



- **NEVER** operate pressure washer without protective housing or covers.
- **DO NOT** wear loose clothing, jewelry or anything that may be caught in the starter or other rotating parts.
- Tie up long hair and remove jewelry.



DANGER-- RISK OF EYE INJURY

- Spray can splash back or propel objects.



- **ALWAYS** wear safety goggles when using this equipment or in vicinity of where equipment is in use.
- Before starting the pressure washer, be sure you are wearing adequate safety goggles.
- **NEVER** substitute safety glasses for safety goggles.



CAUTION– IMPROPER TREATMENT OF PRESSURE WASHER CAN DAMAGE IT AND SHORTEN ITS LIFE AND VOID YOUR WARRANTY

- **NEVER** pull water supply hose to move pressure washer. This could damage hose and/or pump inlet.
- **DO NOT** use hot water, use cold water only.
- **NEVER** turn water supply off while pressure washer engine is running or damage to pump will result.
- **DO NOT** stop spraying water for more than two minutes at a time. Pump operates in bypass mode when spray gun trigger is not pressed. If pump is left in bypass mode for more than two minutes internal components of the pump can be damaged.
- Before starting pressure washer in cold weather, check all parts of the equipment to be sure ice has not formed there.
- **DO NOT** use the pressure washer if excessive noise or vibration is present. Have it repaired immediately.

PLEASE WEAR PROPER APPAREL AND PROTECTORS



Proper Apparel



Electrically
Non-conductive Gloves



Ear Protection



Nonskid Footwear

5. Parts Identification and Features

5.1 Complete Unit-1

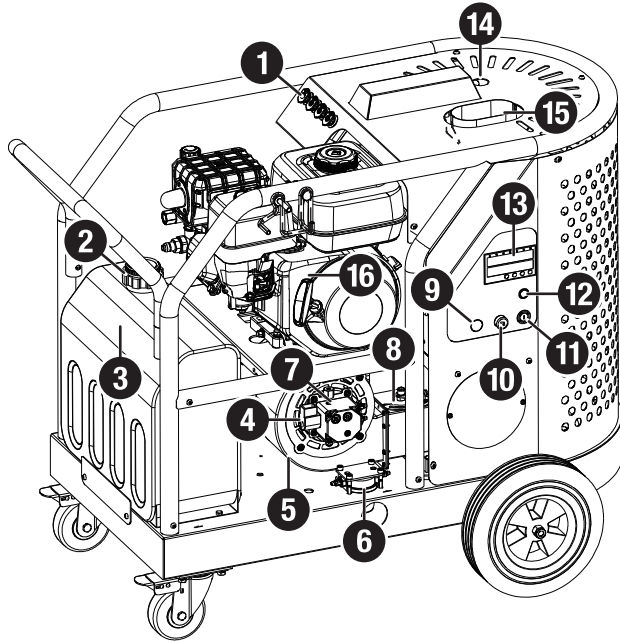

1. Nozzle Tips
2. Fuel Tank Cap
3. Burner Fuel Tank
4. Solenoid Valve
5. Fan ASSY
6. Oil Filter
7. Oil Pump
8. Air Volume Regulator
9. Engine Start Button
10. Engine Stop Button (gas engine only)
11. Burner Switch
12. Burner Working Indicator
13. Temperature Display/Controller
14. Observation Hole
15. Exhaust Discharging Port
16. Engine with 12V recharge

5.2 Complete Unit-2

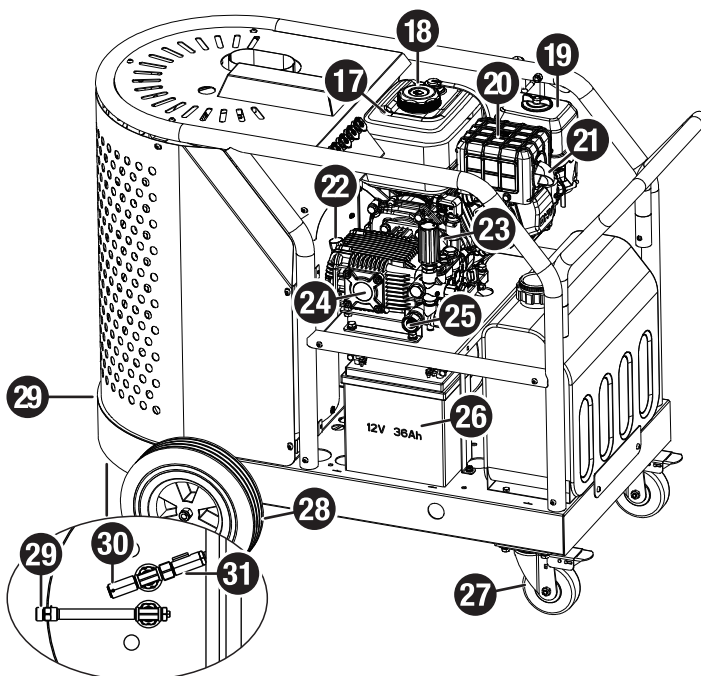

17. Engine Fuel Tank
18. Engine Fuel Tank Cap
19. Engine Air Filter
20. Engine Muffler
21. Exhaust Port
22. Pump Vented Plug
23. Pump Pressure Regulator
24. Pump Oil Gauge
25. Pump Water Inlet Port
26. Battery 12V
27. Caster With Brake
28. Wheel
29. Water Outlet
30. Pressure Safety Valve
31. Water Inlet Flow Sensor

5. Parts Identification and Features (continued)

5.3 Burner System

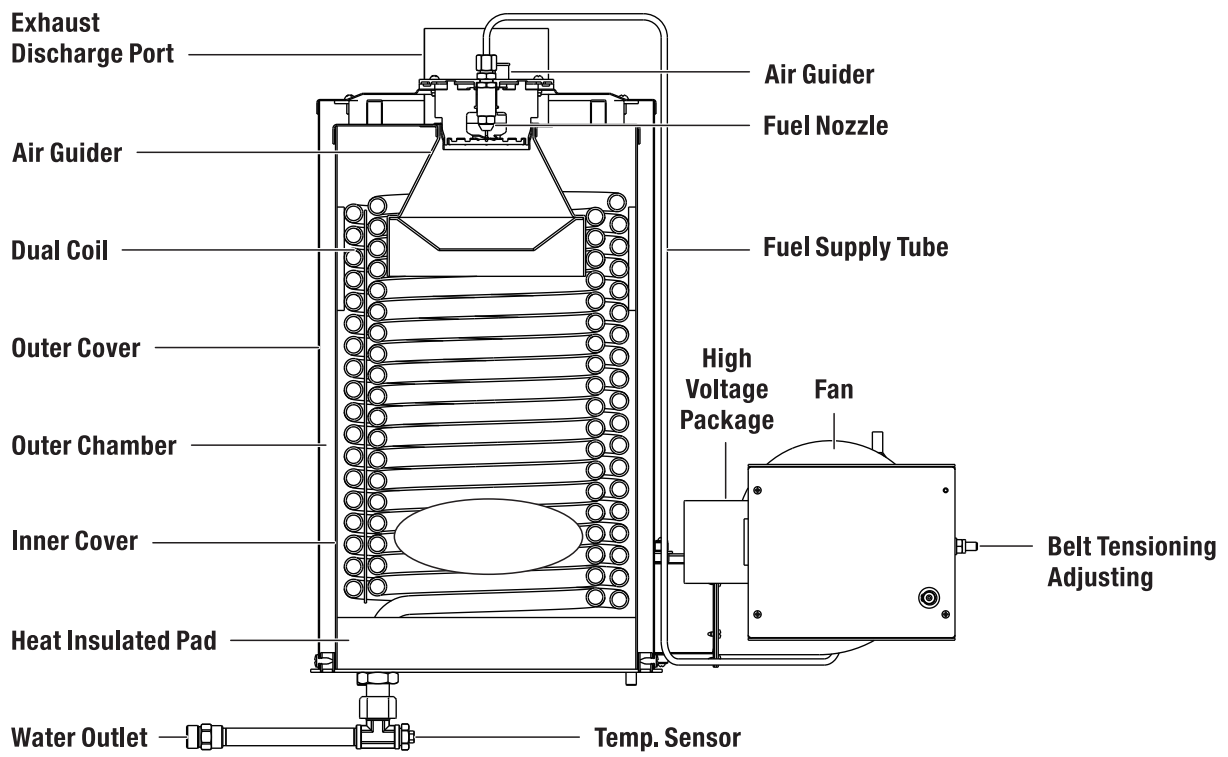

5.4 Ignitions System

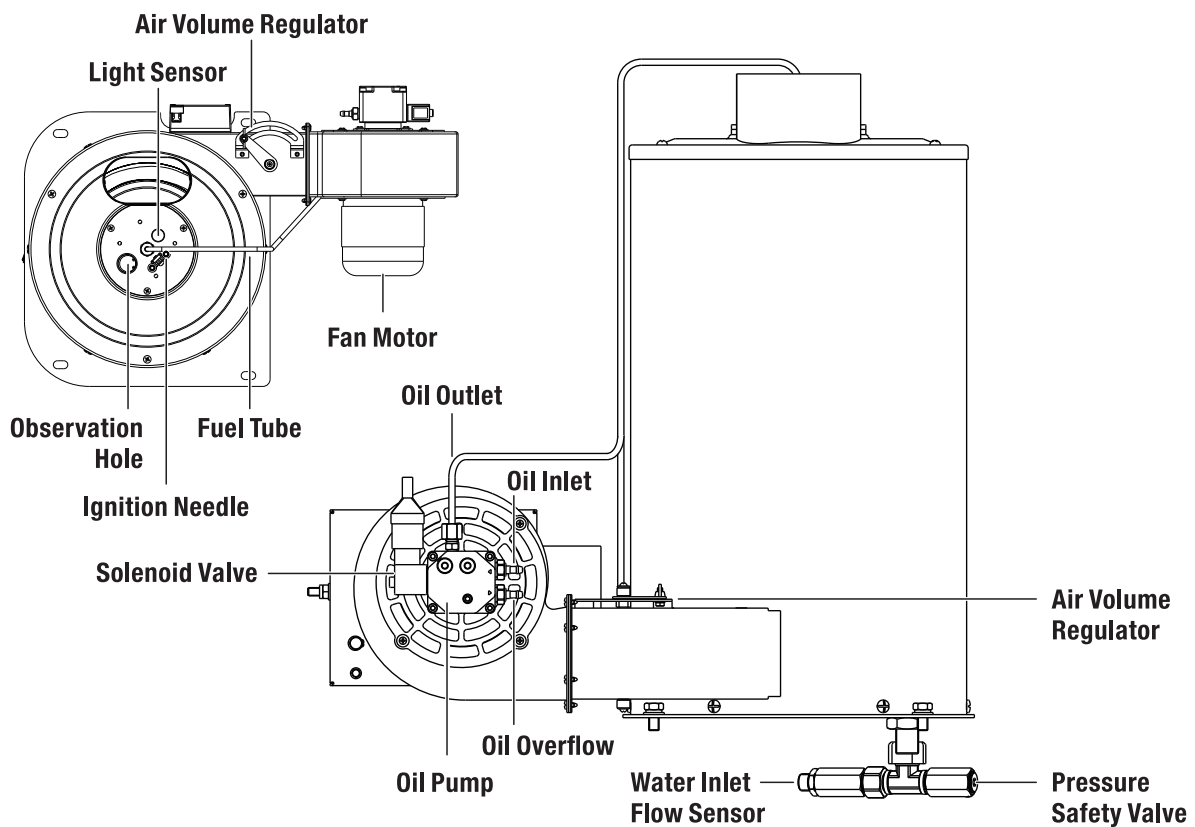

5. Parts Identification and Features(continued)

5.5 High Pressure Pump

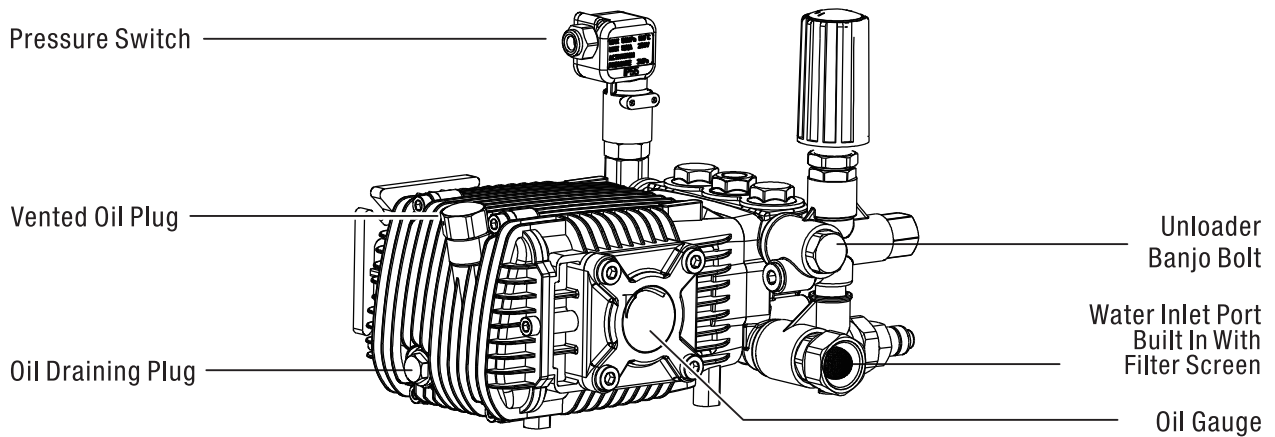
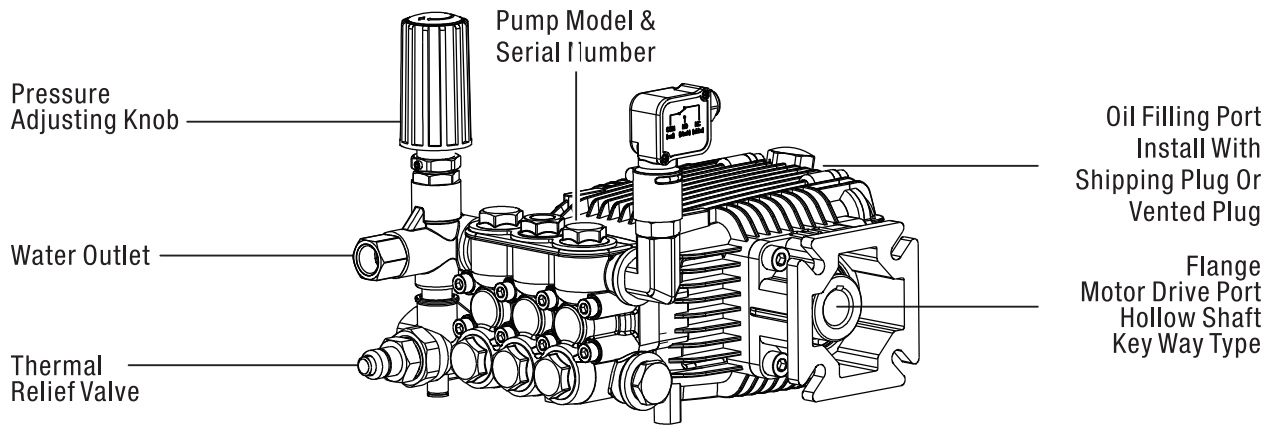

5.6 Gear-reduction Box

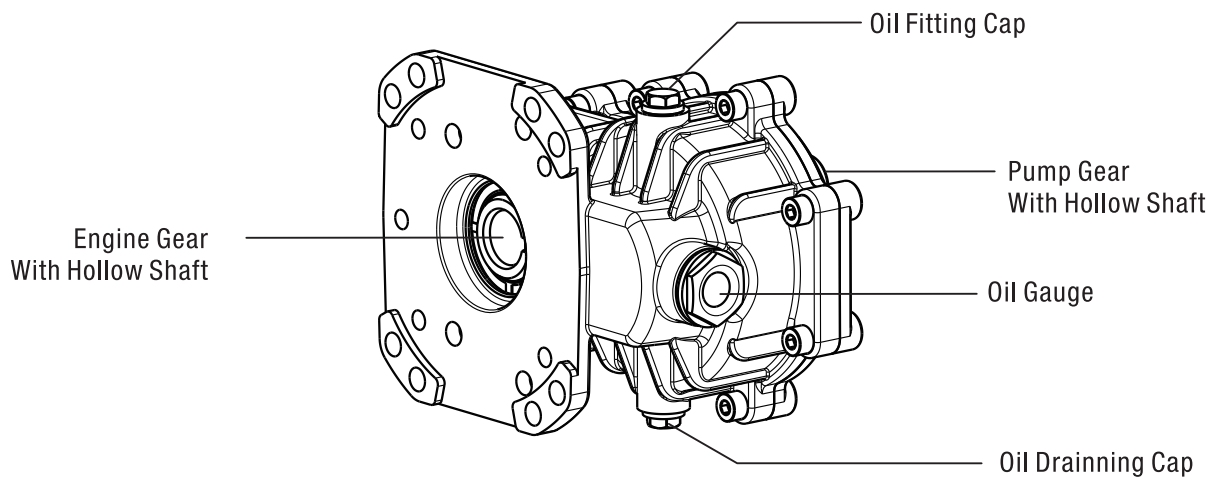

5. Parts Identification and Features (Continued)

5.7 Gasoline Engine

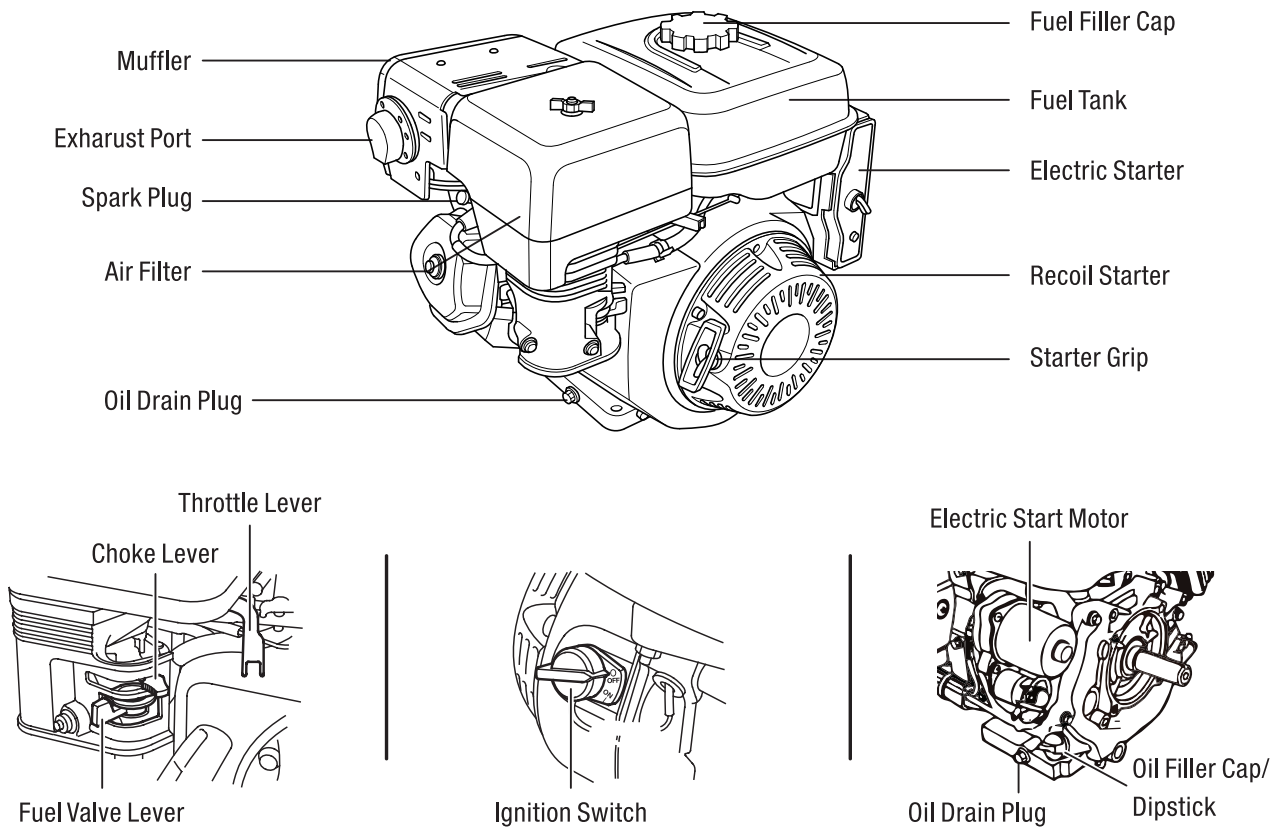

5.8 Diesel Engine

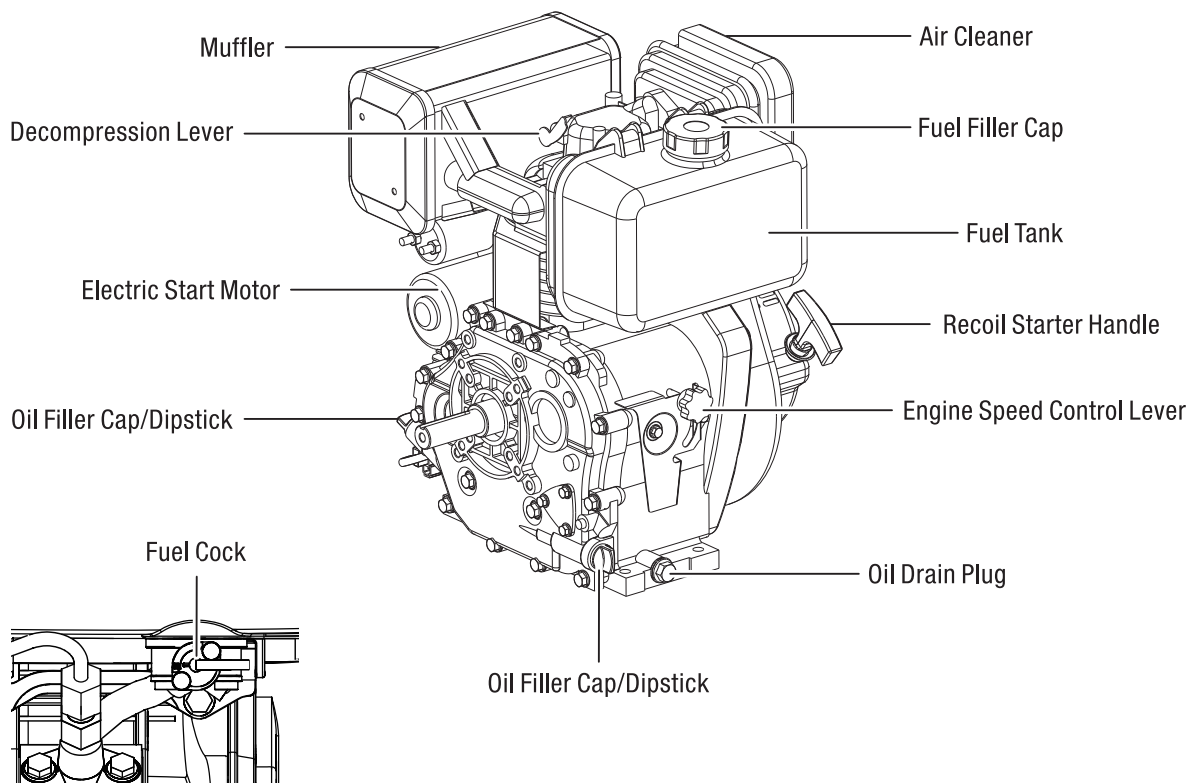

6. Safe Working Environment

Pressure Washer Location

Clearances and Air Movement

 **WARNING**

- Exhaust heat/gases can ignite combustibles, structures or damage fuel tank causing a fire.

Keep at least 5 ft. (1.5 m) clearance on all sides of pressure washer including overhead.



Place pressure washer in a well ventilated area, which will allow for removal of deadly exhaust gas. Do not place pressure washer where exhaust gas could accumulate and enter inside or be drawn into a potentially occupied building. Ensure exhaust gas (A) is kept away from any windows, doors, ventilation intakes, or other openings that can allow exhaust gas to collect in a confined area. Prevailing winds and air currents should be taken in

 **WARNING**

- Running engine gives off carbon monoxide, an odorless, colorless, poison gas.
- Breathing carbon monoxide can cause headache, fatigue, dizziness, vomiting, confusion, seizures, nausea, fainting or death.

Operate pressure washer ONLY outdoors.

Keep exhaust gas from entering a confined area through windows, doors, ventilation intakes, or other openings.

DO NOT start or run engine indoors or in an enclosed area, even if windows and doors are open.

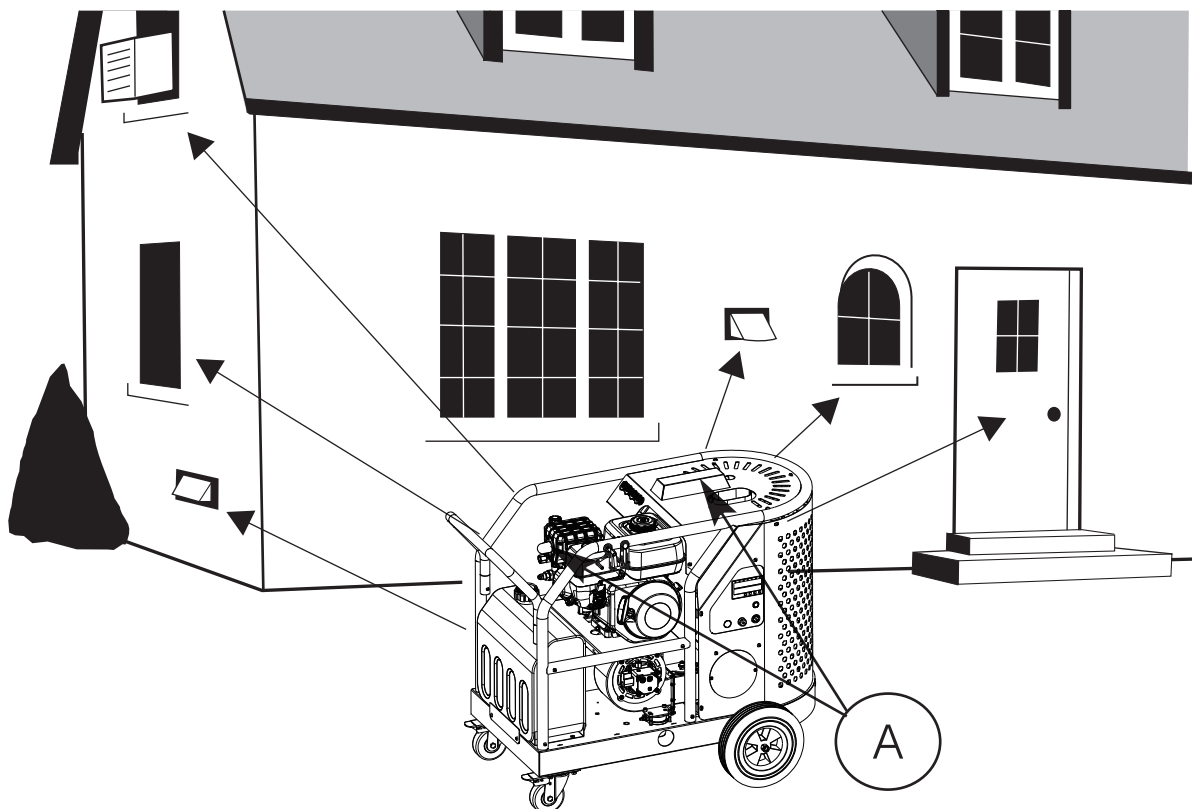

7. Gas Engine Preparing Before Use

7.1 Add Oil To The Gas Engine

1. Place pressure washer on a flat, level surface.
2. Clean area around oil fill and remove yellow oil fill cap.
3. Using oil funnel (optional), slowly pour contents of provided oil bottle into oil fill opening.
4. Replace oil fill cap and fully tighten.

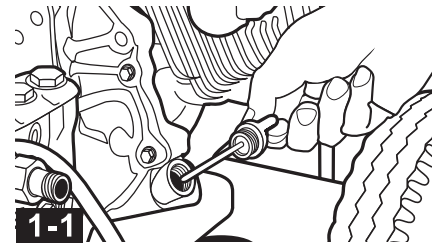

1-1

NOTICE

Improper treatment of pressure washer can damage it and shorten its life.

DO NOT attempt to crank or start the engine before it has been properly serviced with the recommended oil. This may result in an engine failure.

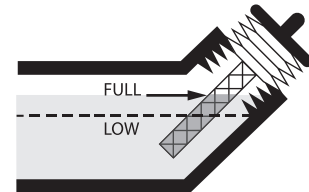

1-2

7.2 Add Fuel To the Gas Engine

WARNING

Failure to use fuel as recommended in this manual will void the warranty.

DO NOT use unapproved gasoline such as E85 (85% ethanol/15% gasoline).

DO NOT mix oil with gasoline.

DO NOT modify engine to run on alternate fuels.

Mix in a fuel stabilizer when adding fuel to pressure washer to protect fuel system from forming gum deposits. If engine doesn't run properly after fueling, switch fuel brands. The engine is certified to run on gasoline. The emission control system for this engine is EM (Engine Modifications).

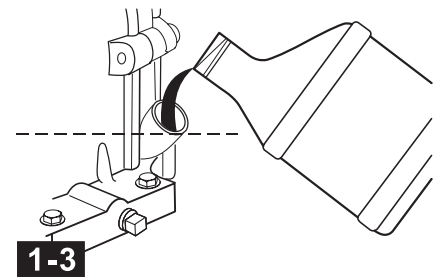

1-3

WARNING

Fuel and fuel vapor are extremely flammable and explosive. Fire or explosion from misuse of fuel can cause severe burns and even death.

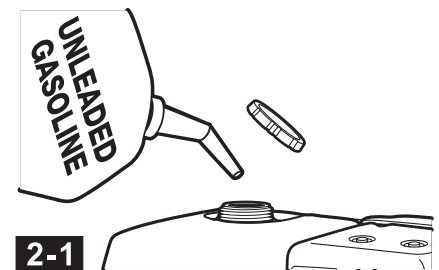

2-1

WHEN ADDING FUEL TO PRESSURE WASHER, OBSERVE THE FOLLOWING STEPS:

1. Turn pressure washer **OFF** and let it cool for at least two minutes before removing fuel cap. Loosen fuel cap slowly to release pressure.
2. Fill fuel tank outdoors.
3. **DO NOT** overfill fuel tank. Leave room for fuel to expand.
4. Wait for spilled fuel to evaporate before cranking engine.
5. Keep fuel away from sparks, open flames, pilot lights, heat and other ignition sources.
6. **DO NOT** light a cigarette or smoke near open fuel tank or container.
7. Clean area around fuel fill cap and slowly remove cap to allow any pressure to escape.
8. Slowly add unleaded gasoline (A) to fuel tank (B). Use extreme caution not to fill fuel above baffle (C). This allow appropriate space for fuel expansion.
9. Install fuel cap and allow any spilled fuel to evaporate before starting engine.

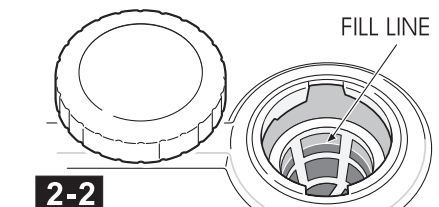

2-2

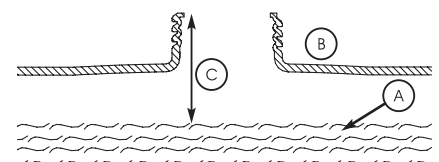

2-3

8. Diesel Engine Preparing Before Use

NOTICE Improper treatment of pressure washer can damage it and shorten its life.

DO NOT attempt to crank or start the engine before it has been properly serviced with the recommended oil. This may result in an engine failure.

8.1 Checking Engine Oil

1. Place pressure washer on a flat, level surface.
1. Remove oil cap/dipstick and wipe with clean cloth.
1. Fully reinsert oil cap/dipstick but do not screw in.
1. Remove oil cap/dipstick, the oil level should be between the H upper level and L level.
1. Fully reinsert oil cap/dipstick and hand tighten. Do not over tightening it.

8.2 Adding Engine Oil

1. Place pressure washer on a flat, level surface.
1. Remove oil cap and add indicated amount of oil at either one of the filler ports, wait one minuted and check oil level, add more oil if necessary.
3. Fully reinsert oil cap and hand tighten it.

8.3 Engine Oil Recommendations

SAE 10W-30 is recommended for general use. Other viscosities shown in the chart may be used when the average temperature in your area is within the indicated range.
Above 80°F (27°C) the use of 10W30 may cause increased oil consumption. Check oil level more frequently.

8.4 Adding Fuel

WARNING Fuel and fuel vapor are extremely flammable and explosive. Fire or explosion from misuse of fuel can cause severe burns and even death.

WHEN ADDING FUEL TO PRESSURE WASHER, OBSERVE THE FOLLOWING STEPS:

1. Turn pressure washer OFF and let it cool for at least two minutes before removing fuel cap. Loosen fuel cap slowly to release pressure.
2. Clean the area around the fuel cap.
3. Remover the fuel cap from the fuel tank.
4. Fill fuel tank outdoors.
5. Stop filling when the fuel is at the same level as the middle ring on the inlet fuel screen. Never overfill the fuel tank.
6. Replace the fuel cap and hand tighten. Do not over-tightening it.

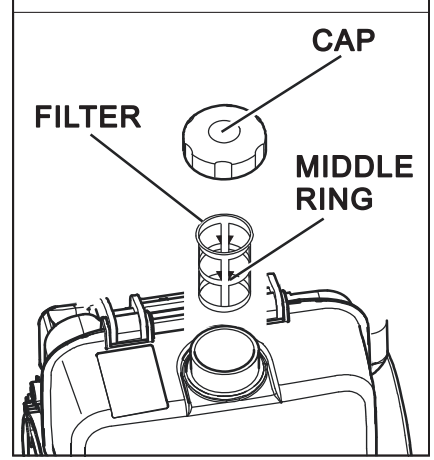
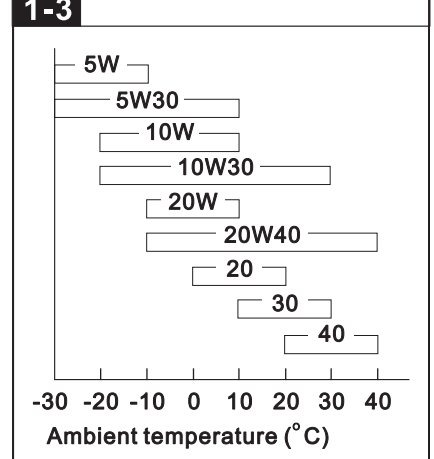
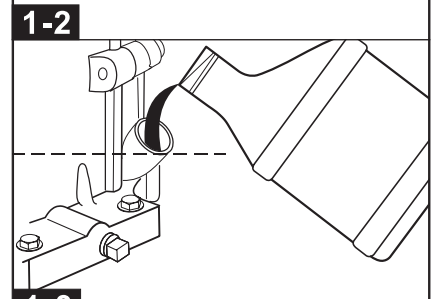
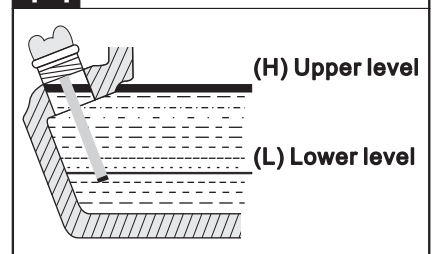
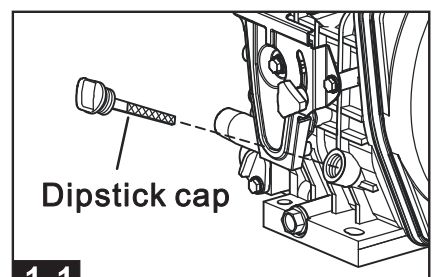

9. Setting Up Before Use

9.1 Adding Oil to Triplex Pump and Gearbox(if applicable)

WARNING Operating the pump with low oil or no oil can cause permanent damage and **VOIDS THE WARRANTY**. Check the pump oil level to make sure it is correct.

- Using an 17mm open-end wrench or socket wrench, remove shipping plug from pressure pump and gearbox. Discard shipping plug.
- Remove pump breather plug from parts bag and insert it into pressure pump.
- Tighten pump breather plug securely by hand. Do not use open-end wrench or socket wrench to tighten.
- Check the sight glass to ensure pump oil is at 1/2 of the sight glass level.
- Add oil to pressure pump if level is below indicator on oil gauge.
- Oil type API SF **SAE 10W-30** or **15W/40**.
- Change after the first 30 hours, then subsequently 100 hours.
- We recommend the use high-quality **NON-DETERGENT** oils, if classified for service SF, SG, SH, SJ or higher. **DO NOT** use special additives. Outdoor temperatures determine the proper oil viscosity.
 - **Below 40°F (4°C) the use of **SAE 30** will result in hard starting.
 - **Above 80°F (27°C) the use of **10W30** may cause increased oil consumption. Check oil level more frequently.

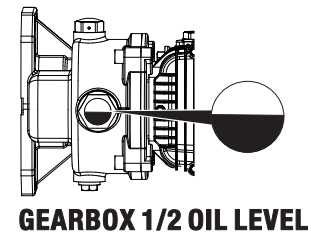
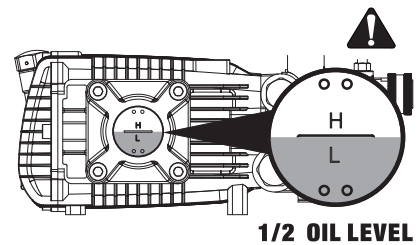
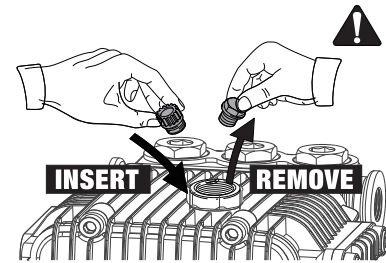

9.2 Adding Fuel To The Burner Fuel Tank

#2 Furnace oil is recommended for the burner oil tank, as it burns cleaner and the burner requires less maintenance. Diesel fuel may be used as an alternative. Do not overfill burner tank.

- Place the pressure washer on a flat level surface.
- Turn the pressure washer off.
- Remove burner fuel cap.
- Add fuel through the fill opening. Do not overfill. Allow at least 1/2" of empty space below fill neck to allow for fuel expansion.
- Replace fuel cap securely and make sure the gasket is in place before starting engine.
- Wipe any excess fuel from unit before starting.

NOTICE **NEVER** use gasoline in your burner tank.

Gasoline is more combustible than fuel oil and could result in a serious explosion. **NEVER** use crankcase or waste oil in your burner. Fuel unit malfunction could result from contamination.

9.3 Check Fuel Level

The fuel cap complete with a float and level indicator. Check fuel level with the fuel tank cap. Always do not overfill burner tank.

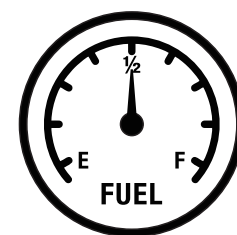
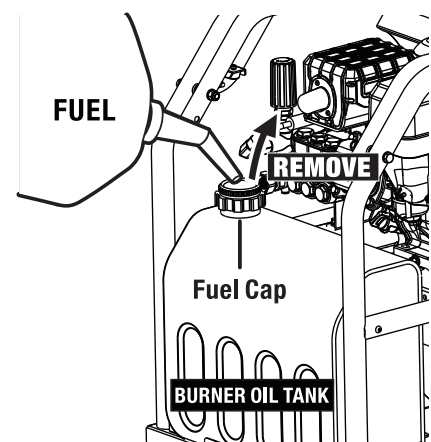

**Fuel Cap With
Level Indicator**

9. Setting Up Before Use (Continued)

9.4 Connecting Spray Wand to Spray Gun

Thread spray the dual wand onto the spray gun

9.5 Attaching High Pressure Hose to Spray Gun

1. Pull slip ring on female quick disconnect fitting of high pressure hose back
2. Insert male quick disconnect fitting on spray gun into female quick disconnect on high pressure hose
3. Release slip ring on female quick disconnect and twist. Listen for "Click" to ensure both quick disconnects are coupled.
4. Pull high pressure hose and spray gun in opposite direction to ensure they do not separate.

⚠ WARNING • Risk of Burn!

The water temperature could become very hot during hot water operation. Be sure the temperature rating of the high pressure hose is for hot water application. NEVER USE COLD WATER HIGH PRESSURE HOSE.

9.6 Attaching High Pressure Hose to Water Outlet

1. Insert the hose fitting pin into the gun fitting port.
2. Turn the swivel nut clockwise tightly on the gun male fitting.

9.7 Connect Hose and Water Supply to Pump .

1. Similarly, attach other end of high pressure hose to high pressure outlet on pump. Pull down on collar of quick connect, slide onto pump and let go of collar. Pull on hose to be sure of tight connection.
2. Before connecting garden hose to water inlet, inspect inlet screen. Clean screen if it contains debris or have it replaced if damaged. **DO NOT** run pressure washer if inlet screen is damaged
3. Run water through your garden hose for 30 seconds to clean out any debris.

IMPORTANT: DO NOT siphon standing water for the water supply. Use **ONLY** cold water (less than 104° F/40 °C).

4. Connect the garden hose (not to exceed 50 feet in length and with the ID no less than 13mm) to the water inlet. Tighten by hand.
5. Turn ON the water, squeeze the trigger to purge the pump system of air and impurities.

NOTE: When connecting the water inlet to the water supply mains, local regulations of your water company must be observed. In some areas, the unit must not be connected directly to the public drinking water supply. This is to ensure there is no feedback of detergents into the water supply. (Direct connection is permitted if a backflow preventer is installed. Check with local authorities for approval.)

9.8 Connect Battery

Make sure the Battery is in good condition and well connected.

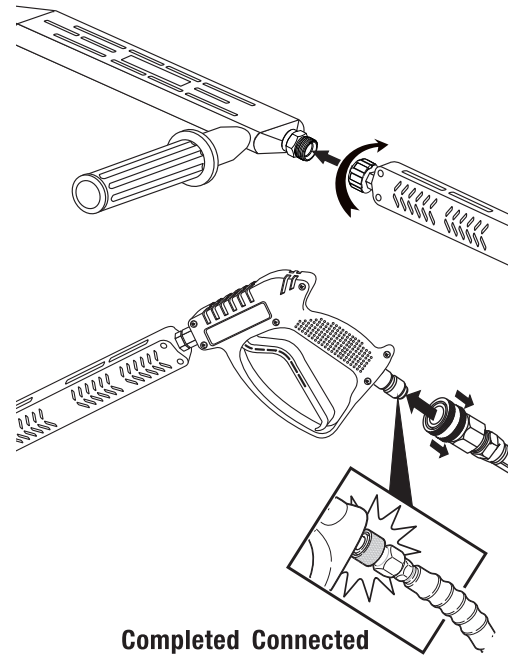

Completed Connected

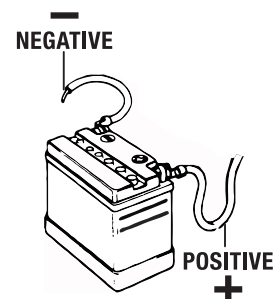
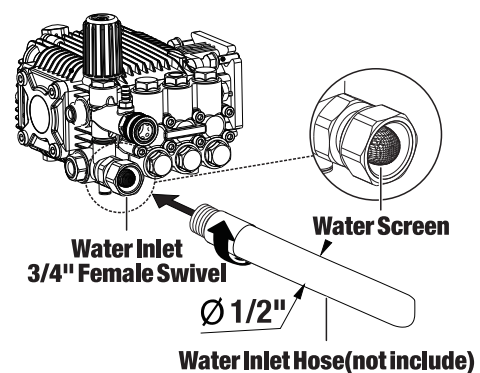
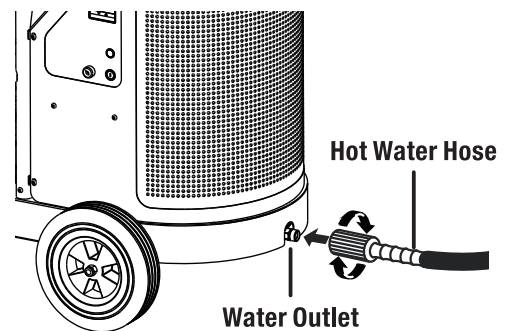

10. Startup and Stopping Procedure-Gas Engine

! WARNING

• RISK OF EYE INJURY.
Spray can splash back or propel objects.

- Always wear safety goggles when using this equipment or in vicinity of where equipment is in use.
- Before starting the pressure washer, be sure you are wearing adequate safety goggles.
- NEVER substitute safety glasses for safety goggles.

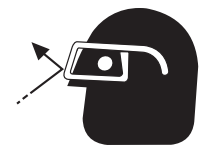

10.1 How to Start Your Pressure Washer

To start your pressure washer for the first time, follow these instructions step-by-step. It is also applies if you have let the pressure washer sit idle for at least a day.

1. Place pressure washer near an outside water source capable of supplying water at a flow rate at least 5GPM/19LPM and no less than 20PSI/1.3BAR at pressure washer end of garden hose.
2. Check that high pressure hose is tightly connected to spray gun and pump.
3. Make sure unit is in a level position.
4. Uncoil high pressure hose completely before using pressure washer.
5. Connect garden hose to water inlet on pressure washer pump.
6. Turn ON water, point gun in a safe direction and squeeze trigger to purge pump system of air and impurities.

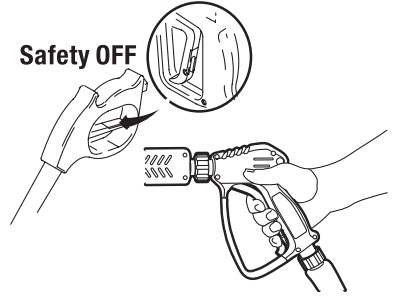
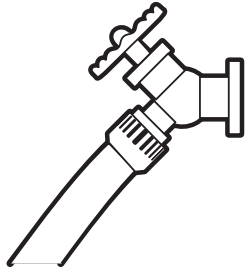

! NOTICE

DO NOT run the pump without the water supply connected and turned on.

Damage to equipment resulting from failure to follow this instruction will **VOID WARRANTY.**

7. Attach wand to spray gun. Tighten by hand.
8. Choose the nozzle, pull back on collar of quick connector, insert nozzle and release collar. Tug on nozzle to make sure it is securely in place.
9. Make sure the Battery is in good condition and well connected.
10. Rotate fuel shut-off valve to "OPEN" position.
11. Move throttle control lever 1/3 toward "FAST" Position.
12. Move choke lever to "CHOKE" position.
13. Make sure the Battery is in good condition and well connected.

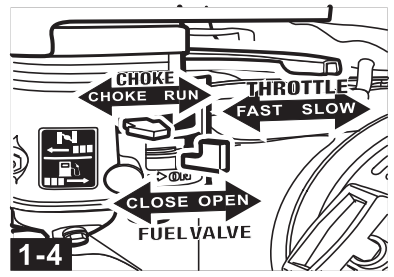

NOTE: For a warm engine, be sure the choke lever is in "RUN" position.

14. Turn the engine switch to the "ON" position, and pressure "ON" on the main control board and hold it there until the engine starts.

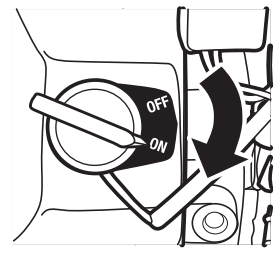

IMPORTANT: If the engine fail to start within 5 seconds, release the key and wait at least 10 seconds before operating the starter again.

15. When engine starts, slowly move choke lever to "RUN" position, as engine warms. If engine falters, move choke lever to "CHOKE" position, then to "RUN" position.
16. After each starting attempt, where engine fails to run, always point gun in safe direction and squeeze spray gun trigger to release high pressure.

Main Controller

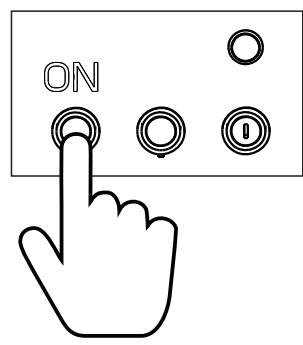

10. Startup and Stopping Procedure-Gas Engine (Continued)

10.2 How to Stop Your Pressure Washer

1. Pressure **"OFF"** on the main control board and hold it there until the engine stops.
2. Turn the engine switch to the **"OFF"** position.
3. Shut off for long periods storage, turn fuel shut-off valve to **"OFF"** position, then hold to pressure **"OFF"** to stop the engine.

NOTE: Avoid letting fuel remain in the carburetor for long periods as this can clog carburetor passages with impurities resulting in malfunctions.

3. Squeeze trigger to release retained high water pressure.

IMPORTANT: Spray gun traps high water pressure, even when engine is stopped and water is disconnected.

Main Controller

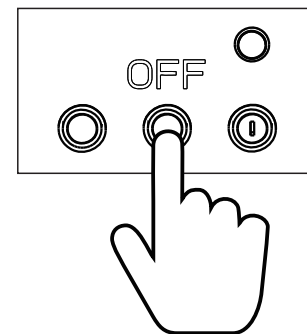

11. Startup and Stopping Procedure-Diesel Engine

11.1 How to Start Your Pressure Washer

1. Place pressure washer near an outside water source capable of
2. Rotate fuel valve to **"On"** position
3. Turn the engine speed control knob **(A)** to the left **(B)**. Slide the engine speed control knob to the **START** position **(C)**. Turn the engine speed control knob to the right **(D)** to tighten it.
4. Make sure the Battery is in good condition and well connected.
5. Hold down the Decompression Lever and release after engine rotate for about 2-3 seconds. Pressure **"ON"** on the main control board and hold it there until the engine starts.

NOTE: If the engine fails to start:

- 1) Wait until the engine complete stop. Engaging the starter while the engine in rotating will damage to the start motor and flywheel.
- 2) Wait at least 30 seconds before you attempt to start the engine again.

IMPORTANT: Allow the Engine to run at no load, low pressure for five minutes after each start-up so Engine can stabilize.

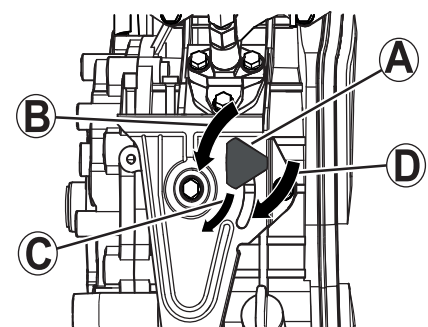
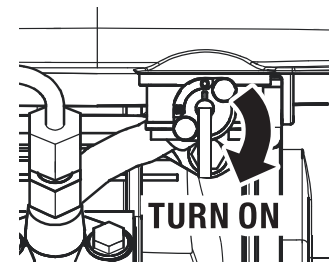

Decompression Lever

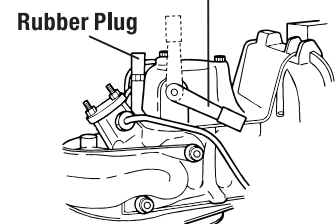

Main Controller

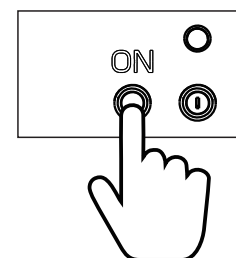

11.2 Cold Start in winter

If the engine is difficult to start in winter, see the engine manual for instructions on how to cold start.

11.3 How to Stop Your Pressure Washer

1. Release spray gun trigger and allow the engine to run unloaded for **3** minutes before shutting down.
2. Turn the engine speed control knob to the left **(B)**, slide the knob to the **STOP (A)** position, turn the knob to the right **(D)** to tighten it.
3. Rotate fuel valve to **"OFF"** position
4. Point spray gun in a safe direction, squeeze spray gun trigger to release retained high water pressure. Engage the gun trigger safety catch.

12. Burn Operation



12.1 To turn on burner

1. Follow the steps outlined for "**Start Procedure(Cold Water)**".
2. Turn the Burner Switch to the "**FAN ON**" position, the motor will start to blow the air into burner, then turn switch to "**ON**" to start burning.

NOTE: On initial start-up, water will begin turning hot in approximately 20 seconds and will reach maximum temperature in approximately 2-1/2 minutes, provided the trigger remains squeezed. The burner will stop firing when the trigger is released.

IMPORTANT: If you experience ignition failure, do not attempt to restart burner! excess fuel and vapors may have accumulated and the chamber may be hot. the unit must cool down before restart can be attempted.

12.2 Temp. Setup Adjustment

1. Press the  for 3 seconds, it will show the code **d600** on the second line of display, and the temperature rate on the first line of the display. Press  to change the code, it will show the code from **d600 to d609**.
2. Code **d601** is the MAX/Limitation temperature. When the water outlet temp. reaches the system will stop burning. Code **d600** is the temp. of reburning. When the temp. drops at this temperature, the system will reburn. Code d602-609 undefined.
3. Choose code **d600** or **d601** and pre Press +/- to adjust the temp. The MAX and reburning can be set about 5°C different. For example, the MAX/Limitation temp. is 90°C and the reburning temp. can be set at 85°C. **DO NOT** set MAX/Limitation temp. over 100°C.
4. Finish adjusting and hold press  for 2 seconds to set, or leave the button. It will AUTO set after 10 seconds.

12.3 Air Adjustment

Machines are preset and performance tested at the factory — **elevation 30M/100FT above sea level**. A one time correction for your location will pay off in economy, performance and extended service life. If a smoky or eye-burning exhaust is being emitted from the stack, two things should be checked. **First**, check the fuel to be certain that kerosene or No. 1 home heating fuel is being used. **Next**, check the air adjustment on the burner. An oily, black, smoky fire indicates a lack of air and the air band should be moved to allow the air to flow through the burner. Sharp, eye-burning white fumes indicate too much air flowing through the combustion chamber. The air band should be moved to allow less air to flow through the burner.

To adjust: start machine and turn burner ON. Loosen the locking screws and close air shutter until black smoke appears from burner exhaust vent. Note air band position. Next, slowly open the air shutter until white smoke just starts to appear. Turn air shutter halfway back to the black smoke position previously noted. Tighten lock-ing screws.

12.3 To shut off burner

Turn the switch to "**FAN ON**" position about 1 min and wait all hot air release from the burner, then turn the switch to "**OFF**". Allow the engine/motor to continue to run, pull the trigger gun to allow water flow to run through the coil for about 2mins prior to complete shutting of the system.

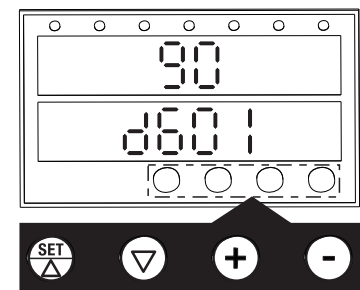
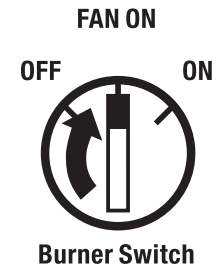

Thermostat
(Temperature Control)

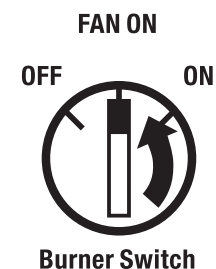
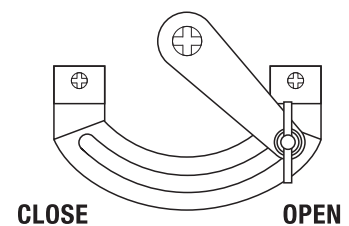

13. Using Nozzles

13.1 Attaching Pressure Nozzles To Spray Wand

1. Engage trigger lock on spray gun.
2. Pull slip ring on female quick-disconnect fitting of spray wand back.
3. Insert nozzle into female quick-disconnect socket on spray wand.
4. Release slip ring on female quick-disconnect and twist. Listen for “lick” to ensure both quick-disconnects are coupled.
5. Pull high pressure nozzle and spray wand in opposite direction to ensure they do not separate.

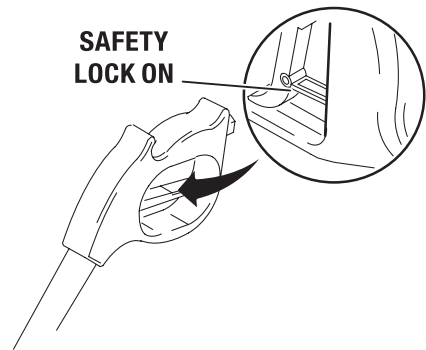

13.2 Interchanging Pressure Nozzles

Turn off pressure washer before attempting to change pressure nozzles. Pull slip ring on the quick disconnect socket to remove the nozzle. Inset the new nozzle according to the “Attaching Nozzle” Procedure.

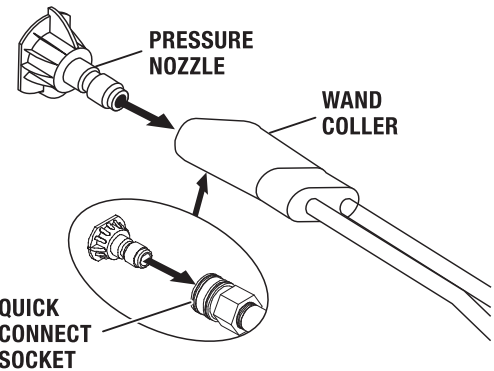

⚠ WARNING • Risk of Burn!

The water temperature could become very hot during hot water operation. Be cautious when interchanging the pressure nozzle.

13.3 Nozzles Size Guide

The pressure washer comes with five spray nozzles. Each nozzle is color coded and delivers a specific spray pattern and pressure for a particular cleaning job. The size of the nozzle determines the size of the fan spray and the pressure out of the nozzle. They are stored in receptacles on a panel mounted to the handle of the washer. Colors on the panel identify nozzle location and spray panel.

⚠ WARNING

- Pressure washer produces fluid pressures and velocities high enough to penetrate human and animal flesh which could result in serious injury or amputation.
- Do not point pressure washer in direction of people or animals.
- High velocity fluid spray can cause objects to break, propelling particles at high speeds.

0° Nozzle - Red: This nozzle delivers a pinpoint stream of pressurized water and is extremely powerful. It covers only a small area of cleaning. This nozzle should only be directed at surfaces that can withstand high pressure such as metal or concrete. Do not use this nozzle to clean wood.

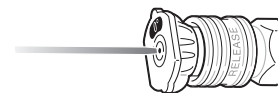

15° Nozzle - Yellow: This nozzle delivers a powerful 15 degree spray pattern for intense cleaning of small areas. This nozzle should only be used on areas and materials that can withstand high pressure.

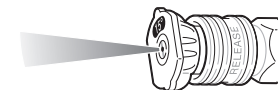

25° Nozzle - Green: This nozzle delivers a 25 degree spray pattern for intense cleaning of larger areas. This nozzle should only be used on areas that can withstand pressure from this nozzle.

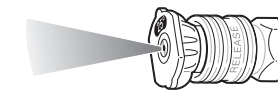

40° Nozzle - White: This nozzle delivers a 40 degree spray pattern and a less powerful stream of water. This nozzle can cover a wide area and should be used for most general cleaning jobs.

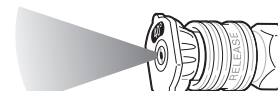

Chemical Nozzle - Black: This nozzle is used to apply special chemicals and cleaning solutions. This nozzle produces the weakest pressure stream of the five nozzles.

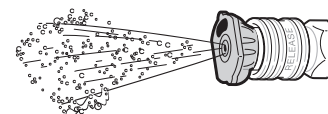

14. Adjusting Spray Pressure

14. Pressure Rinsing

1. Remove black spray tip from nozzle extension.
2. Select and install desired high pressure spray tip.
3. Keep spray gun a safe distance from area you plan to spray.
4. Increase (decrease) spray pressure by turning pressure control knob clockwise (counterclockwise).
5. Apply a high pressure spray to a small area and then check surface for damage. If no damage is found, you can assume it is okay to continue rinsing.
6. Start at top of area to be rinsed, working down with same overlapping strokes as you used for cleaning.

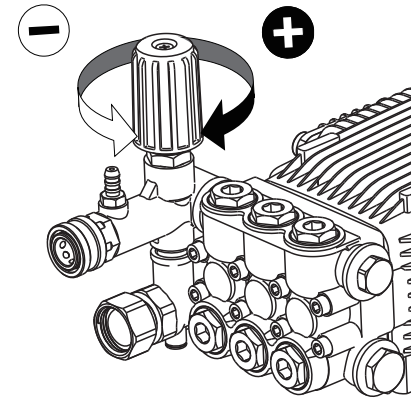

15. Using Chemicals & Detergents (if applicable)

NOTE: Use only detergents designed for pressure washers; household detergents, acids, alkalines, bleaches, solvents, flammable material, or industrial grade solutions can damage the pump. Many detergents may require mixing prior to use. Prepare cleaning solution as instructed on the solution bottle.

15.1 Set Up Procedure

1. Attach the chemical hose onto the barbed fitting situated near the back of the high pressure hose connection.
2. Press the other end of the chemical hose (with the filter attached) into the container holding the chemicals or detergents you are using.
3. To activate the chemical injector by turning the side handle "CLOCKWISE" and turning the handle "COUNTERCLOCKWISE" to control the amount of pressure and chemical flow.

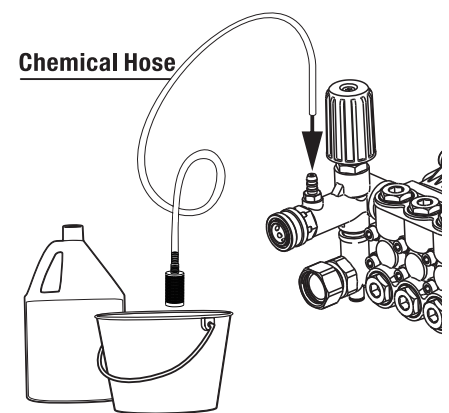

BRASS SOAP NOZZLE

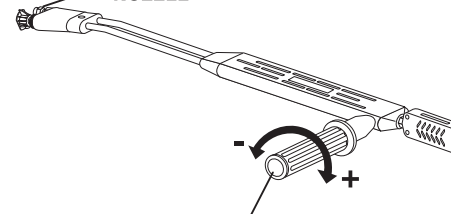

H-L CHANGE OVER AND VARIABLE PRESSURE CONTROL HANDLE

15.2 Chemical Cleaning

1. Spray the chemicals onto a dry surface using the procedures outlined in previous sections. Start at the lower portion of the cleaning area and working upwards, using long, even, overlapping strokes.
2. Always ensure that the filter is fully submerged in the cleaning solution at all times.
3. Allow the detergent to soak in for 3-5 minutes before washing and rinsing.
4. Re-apply as needed to prevent the surface from drying. Do not allow the detergent to dry on to the cleaning surface to prevent streaking.

NOTE: Detergent cannot be applied with the high pressure spray tips (white, green, yellow or red)

15.3 After Chemical Cleaning

IMPORTANT: You will need to flush the detergent siphoning system after each use by placing the filter into a bucket of clean water then run the pressure washer in low pressure for 1-2 minutes.

1. After using chemicals, soaps and detergents it is necessary to thoroughly clean the pressure washer.
2. Place the chemical hose in a container of clean water.
3. Turn on the pressure washer and hold the trigger on the spray gun top draw clean water through the system to clean it thoroughly.

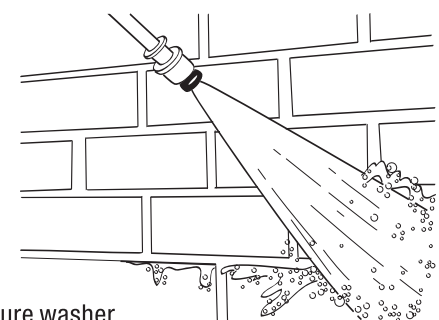

16. Maintenance

To ensure efficient operation and longer life of your pressure washer a routine maintenance schedule should be prepared and followed. If the equipment is used in unusual conditions such as high-temperature or dusty conditions more frequent maintenance checks will be required.

WARNING

Before performing any maintenance be aware that the equipment should be completely shutdown, depressurized and allowed to cool down. This will ensure that no injuries can be sustained by moving parts, water pressure or hot surfaces.

Engine contains flammable fuel do not smoke near or work near naked flames while maintaining this equipment. Please note: All repairs should be carried out by Dealer approved engineers. All replacement parts should be supplied or recommended by the Dealer. Any unapproved repairs or modifications will invalidate the warranty.

16.1 Engine:

Check the engine regularly, replace oil, clean spark plugs and maintain parts as required.

16.2 Pump Oil:

Change the pump oil regularly. Change the pump oil after the first 30 hours of work and successively every 100 hours. In either case ensure that the oil is changed at least once a year. Check with your nearest Dealer for advice on the best Pump Oil to use with this equipment if you are unsure.

NOTICE

Avoid prolonged or repeated skin contact with used motor oil.

Used motor oil has been shown to cause skin cancer in certain laboratory animals. Thoroughly wash exposed areas with soap and water.



KEEP OUT OF REACH OF CHILDREN. DON'T POLLUTE. CONSERVE RESOURCES. RETURN USED OIL TO COLLECTION CENTERS.

16.3 Nozzle Tips:

If the nozzle becomes clogged with dirt and debris excessive pressure can build up. If the nozzle becomes partially clogged or restricted the pump pressure will fluctuate and can become harmful and dangerous.

Clean the nozzle immediately and follow these instructions:

1. Shut-off the engine and turn off / disconnect the water supply.
2. Pull the trigger on the gun to relieve any water pressure.
3. Disconnect the lance from the gun.
4. Remove the nozzle from the lance - remove any obstructions with the nozzle cleaning tool and back flush with clean water.
5. Direct the water supply into the spray wand end to back flush loosened particles for 30 seconds.
6. Reassemble the nozzle onto the lance.
7. Reconnect the lance to the gun and turn on the water supply.
8. Start the washer pump and place the lance into the high pressure setting to test.

Nozzle Cleaning Pin

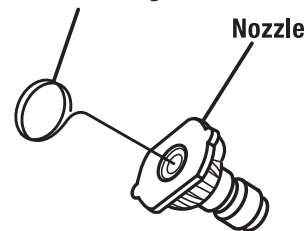

16.4 Cleaning The Water Filter:

The water filter should be checked regularly and cleaned if necessary:

1. Remove the filter by grasping the end and removing it from the water inlet on the pump.
2. Clean the filter by flushing it with water on both sides.
3. Re-insert the filter in the water inlet on the pump.

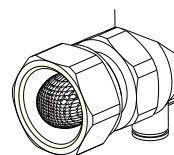

Water Filter In-place

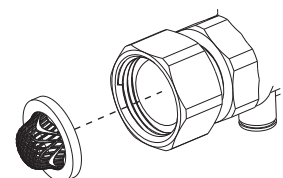

Water Filter Removed

16. Maintenance (Continued)

16.5 High Pressure Hose:

Replace the high pressure hose when the hose have any of Cover damaged Burst. Bubbles/blisters.Kinked/collapsed.



NOTICE

The high pressure stream of water can cut through skin and its underlying tissues, leading to serious injury and possible amputation. Never repair high pressure hose. Replace it.



16.6 Cleaning the Fuel Tank Filter:

The fuel tank filter should be removed and cleaned after every 150 hours of running or every 3 months using an environmentally -friendly water-based de-greasing agent. Refit when clean.

16.7 Burner Maintenance

NOTE: Repair of the burner is to be done by authorized and trained burner professionals only.

The oil filter cartridge should be replaced every year to prevent fuel contamination and plugging of fuel pump and nozzle of oi burner.

The nozzle should also be replaced at least once every year or twice if used daily and if poor combustion begins to occur.

If the burner floods with oil: Run machine with heat on until all excess oil is burned off (this can take up to a couple of hours).

If excess oil is not properly dealt with, the ceramic casing can absorb excess oil, causing a fire hazard. **DO NOT LEAVE MACHINE UNATTENDED WHILE MACHINE IS FLOODED.**

16.8 Maintenance Schedule

Item	Task Description	Each Use	1st Month (20Hrs)	Frequency Each Season (50Hrs)	Every 6 Months (100Hrs)	Every YEAR (300Hrs)
Engine Oil	Oil Level Check	•				
	Replace		•		•	
Reduction Gear Oil (If applicable)	Oil Level Check	•				
	Replace		•		•	
Air Cleaner/filter	Check	•				
	Clean			•x	•x	
	Replace					•
Deposit Cup	Clean				•	
Spark Plug	Clean,Adjust				•	
	Replace					•
Spark Eliminator	Clean				•	
Idling	Check,Adjust					•
Valve Clearance	Check,Adjust					•
Fuel Tank & Filter	Clean					•
Fuel Supply Line	Check	Check with your Dealer for advice if any problem are detected				
Oil Filter Cartridge	Replace					•x
Burner Nozzle	Replace					•x

17. Storage

17.1 After General / Regular Use

1. Drain all water from the high pressure hose, coil it and hang on the cradle on the petrol washer frame. If chemicals where used ensure the pump and chemical hose are thoroughly cleaned out.
2. Drain all the water from the gun and lance by holding the gun in a vertical position with the nozzle end pointing down and squeeze the trigger. Store in the gun/hose holder.

17. Storage (Continued)

17.2 Preparation for Winter and Long-term Storage

Note: It is recommended that you follow these steps to protect the internal seals of the pump when storing the equipment for more than 30 days and or when, freezing temperatures are expected.

1. Obtain a funnel, 200ml of antifreeze and approximately 1M of garden hose with a male hose connector attached to one end.
2. Disconnect the spark plug wire.
3. Connect the hose to water inlet on the pump.
4. Pour the antifreeze into the hose via the funnel.
5. Pull the engine starter cord slowly several times until antifreeze comes out of the high pressure water hose connection on the pump.
6. Remove the short hose from the water inlet on the pump.
7. Reconnect the spark plug wire.

17.3 Long Term Storage Instructions (DIESEL ENGINE)

Follow the instructions below if you plan to storing the D engine for a long periods of time.

- 1) Run the engine for 3 minutes to burn out the excess fuel in the chamber.
- 2) Stop the engine. Drain the engine lube oil while the engine is still warm and refill it with the new oil.
- 3) Remove the rubber plug on the rocker arm and put about 2cc of the lubricant into it, put it back in place
- 4) Recoil starting
Push the decompression lever down and hold it while you pull the recoil starter 2 or 3 times. (Do not start the engine).
- 5) Electric starting
Hold down the decompression lever and turn the start key switch to the START position. Let the engine rotate for about 2-3 seconds
- 6) Pull the decompression lever up and pull the recoil starter slowly until you feel resistance. The resistance point occurs on the compression stroke where the intake and exhaust valves are closed. It is also the will prevent moisture from entering the chamber to cause rust.
- 7) Wipe the oil and dirt from the engine.

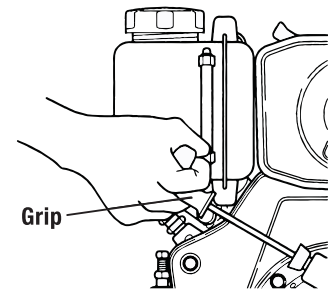
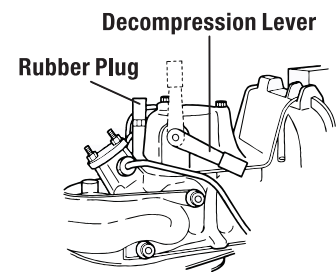

17.4 Service After Storage (Gas Engine)

Before reusing the equipment after storage, you should carry out the following to keep the equipment in good condition.

Storage Time	Service Tank
Within one month	No service required
One - two months	Drain out the existing fuel out of the fuel tank and fresh fuel
Two months - one year	Drain out the existing fuel out of the fuel tank and fresh fuel Drain the fuel out of carburetor Empty the deposit cup
Over a year	Drain out the existing fuel out of the fuel tank and fresh fuel Drain the fuel out of carburetor Empty the deposit cup Close the FUEL VALVE and wait engine to stop

Key:

- * = Unscrew the drain plug and drain out the fuel in the carburetor
- ** = Turn engine switch to the off position, disconnect the deposit cup and empty contents safely

Note: Do not dump oil vessels or discarded engine oil onto the ground. Take all discarded engine oil in a closed container to your nearest recycling station.

18. Troubleshooting

PROBLEM	PROBABLE CAUSE	SOLUTION
Engine shuts down when running.	<ol style="list-style-type: none"> 1.Out of fuel. 2.Low Engine Oil 	<ol style="list-style-type: none"> 1.Fill fuel tank. 2. Add oil.
Engine will not start; or starts and runs rough.	<ol style="list-style-type: none"> 1.Rocker switch set to "OFF" position. 2.Fuel valve is in "OFF" position. 3.Dirty air cleaner 4.Out of fuel. 5.Stale fuel. 6.Spark plug wire not connected to spark plug. 7.Bad spark plug. 8.Water in fuel. 9.Flooded. 10.Excessively rich fuel/air mixture. 11.Intake valve stuck open or closed. 12.Engine has lost compression. 13.Low engine oil. 14.Wrong Fuel. 15.Engine is too hot 16.Chock is in wrong position 17.Pressure Builds up after 2 pulls on recoil starter or after initial use. 	<ol style="list-style-type: none"> 1.Set switch to "ON" position. 2.Turn fuel valve to "ON" position. 3.Clean or replace air cleaner 4.Fill fuel tank. 5.Drain fuel tank and carburetor; fill with fresh fuel. 6.Connect wire to spark plug. 7.Replace spark plug. 8.Drain fuel tank and carburetor; fill with fresh fuel. 9.Wait 5 minutes and re-crank engine. 10.Contact authorized service facility. 11.Contact authorized service facility. 12.Contact authorized service facility. 13.Add oil. 14.Use recommended fuel. 15.Allow engine to cool 16.Change chock position 17.Squeeze gun trigger to relieve pressure.
Engine "Hunts" or falters.	<ol style="list-style-type: none"> 1.Carburetor Is running too rich or too lean. 	<ol style="list-style-type: none"> 1.Contact authorized service facility.
Engine lacks power.	<ol style="list-style-type: none"> 1.Cylinder pressure is low. 2.Dirty air cleaner 	<ol style="list-style-type: none"> 1.Contact authorized service facility. 2.Replace air filter.
No pressure or Low pressure.	<ol style="list-style-type: none"> 1.Spray wand not set to high pressure. 2.Lower water supply. 3.Hose fitting leaks during high pressure. 4.Nozzle obstructed. 5.Water filter screen obstructed. 6.Defective thermal relief valve. 7.Air in hose. 8.Choke lever in choke position. 9.Throttle control lever is hot in fast position. 10.High pressure too long. 	<ol style="list-style-type: none"> 1.See "Using Spray Wand" section. 2.Water supply must be 5 GPM @ 20 psi. 3.Tighten hose fitting. Use thread sealant tape if necessary. 5.Remove and clean filter. 6.Call Customer Service: 7.Stop engine and water source. Disconnect water source from pump inlet and turn water source to ON to remove all air from hose. When steady stream of water is present, turn water source to OFF. Re-connect water source to pump inlet and turn on water source. Squeeze trigger to remove remaining air. 8.Move choke to NO CHOKE position. 9.Move throttle control lever from fast position. 10.Use High pressure hose under 100 ft (30M).

18. Troubleshooting (Continued)

PROBLEM	PROBABLE CAUSE	SOLUTION
Pump will not draw Chemicals	<ol style="list-style-type: none"> 1.Spray wand not set to low pressure.. 2.Chemical filter clogged. 3.Chemical screen not in chemical. 4.Chemical solution too thick. 5.Pressure hose too long 6.Chemical build-up in chemical injector. 	<ol style="list-style-type: none"> 1. See "Using Spray Wand" section. 2. Clean Filter. 3. Ensure end of chemical hose is fully submerged into chemicals. 4. Dilute chemical. Chemical solutions should have same consistency as water. 5. Lengthen water supply hose instead of pressure hose. 6. Have parts cleaned or replaced by authorized dealer.
No or low pressure (after period of normal use).	<ol style="list-style-type: none"> 1. Worn seal or packing. 2. Worn or obstructed valves. 3. Worn unloader piston. 4. Worn E-Z start valve. 	<p>Have parts cleaned or replaced by authorized dealer.</p>
Water leaking at spray gun/spray wand connection.	<ol style="list-style-type: none"> 1. Worn or broken O-ring. 2. Loose hose connection. 	<ol style="list-style-type: none"> 1. Check and replace O-ring. 2. Tighten hose connection.
Water leaking at pump.	<ol style="list-style-type: none"> 1. Loose connections. 2. Piston packings worn. 3. Worn or broken O-rings. 4. Pump head or tubes damaged from freezing. 	<ol style="list-style-type: none"> 1. Tighten connections. 2. Have parts cleaned or replaced by authorized dealer. 3. Check and replace O-ring 4. Have parts cleaned or replaced by authorized dealer.
Oil leaking at pump	<ol style="list-style-type: none"> 1. Oil seals worn. 2. Loose drain plug. 3. Worn drain plug O-ring. 4. Worn fill plug O-ring. 5. Pump overfilled. 6. Incorrect oil used. 7. Vent plug clogged. 	<ol style="list-style-type: none"> 1. Have parts cleaned or replaced by authorized dealer. 2. Tighten drain plug. 3. Inspect and replace O-ring. 4. Inspect and replace O-ring. 5. Check for correct amount. 6. Drain and refill with correct type and amount of oil. 7. Clean vent plug. Use air hose to free it of blockage. If problem persists, replace vent plug.
No Hot Water	Dead Battery	<ol style="list-style-type: none"> 1. Make sure your battery is fully charged. 2. If the battery's charge is not full, please replace or recharge your battery.
	Damaged Thermostat	<ol style="list-style-type: none"> 1. Make sure thermostat is connected properly. 2. If burner fan does not come on when you turn thermostat dial, replace thermostat.

18. Troubleshooting (Continued)

PROBLEM	PROBABLE CAUSE	SOLUTION
No Hot Water	Damaged Pressure Switch	<ol style="list-style-type: none"> 1. Make sure pressure switch is connected properly to burner unit. Take cover off pressure switch by unscrewing the 4 screws on the front part of the switch (switch is located on pump). Without touching the contacts that conduct current, push on the little button found on the micro switch (button is located directly above the part that attaches directly into pump). 2. If burner comes on, replace pressure switch. 3. If burner does not come on, make sure there is current going through switch (consult a professional for this if you do not know how to do this properly as you can get severely injured by the electrical current connected to your machine). 4. If current properly flows through pressure switch to burner, check ignitor.
	Damaged Ignitor	<ol style="list-style-type: none"> 1. Please call a repair center for help to conduct tests on the ignitor. 2. If you see vapor coming out the top of the coil when you try to turn the burner on while the machine is in use, fuel is passing through the system properly but the ignitor is unable to produce a spark. Replace the ignitor. 3. If you don't see vapor, check the fuel line.
	Plugged Filter Or No Fuel	<ol style="list-style-type: none"> 1. Make sure you have enough fuel in the tank. 2. If you have fuel, make sure the filter and fuel line are not plugged or damaged.
Black smoking	Oxygen in short supply	<ol style="list-style-type: none"> 1. Increase the air supply. 2. Reduce the oil pressure.
White smoking (after initial start)	Fuel fog blow off	<ol style="list-style-type: none"> 1. Decrease the air supply. 2. Increase the oil pressure.
Alarm sound	Ignition fail for three times	<ol style="list-style-type: none"> 1. No or less fuel. 2. Carbon deposits in the ignition needle. 3. Ignition needle not set in position. 4. The high voltage ignitor is faulty. 5. Fuel injection relay is faulty.
Gun ON/OFF action cannot control burning ON/OFF	<ol style="list-style-type: none"> 1. Burner not turn to ON position. 2. High pressure nozzle not in use. 3. Pressure switch faulty. 	<ol style="list-style-type: none"> 1. Turn the burner switch to ON position. 2. Use the high pressure nozzle. 3. Change the pressure switch.

19. Circuit Diagram

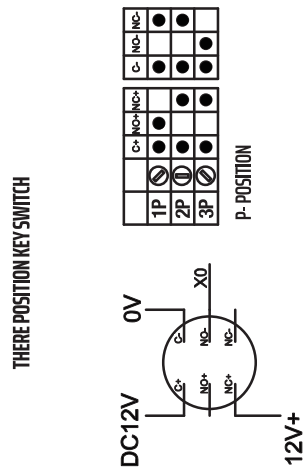
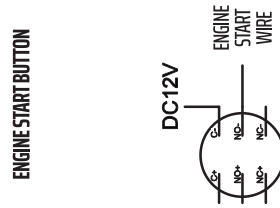
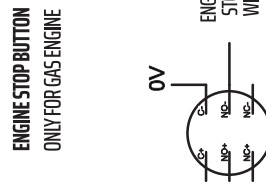
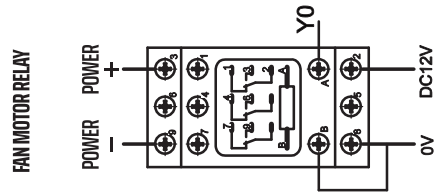
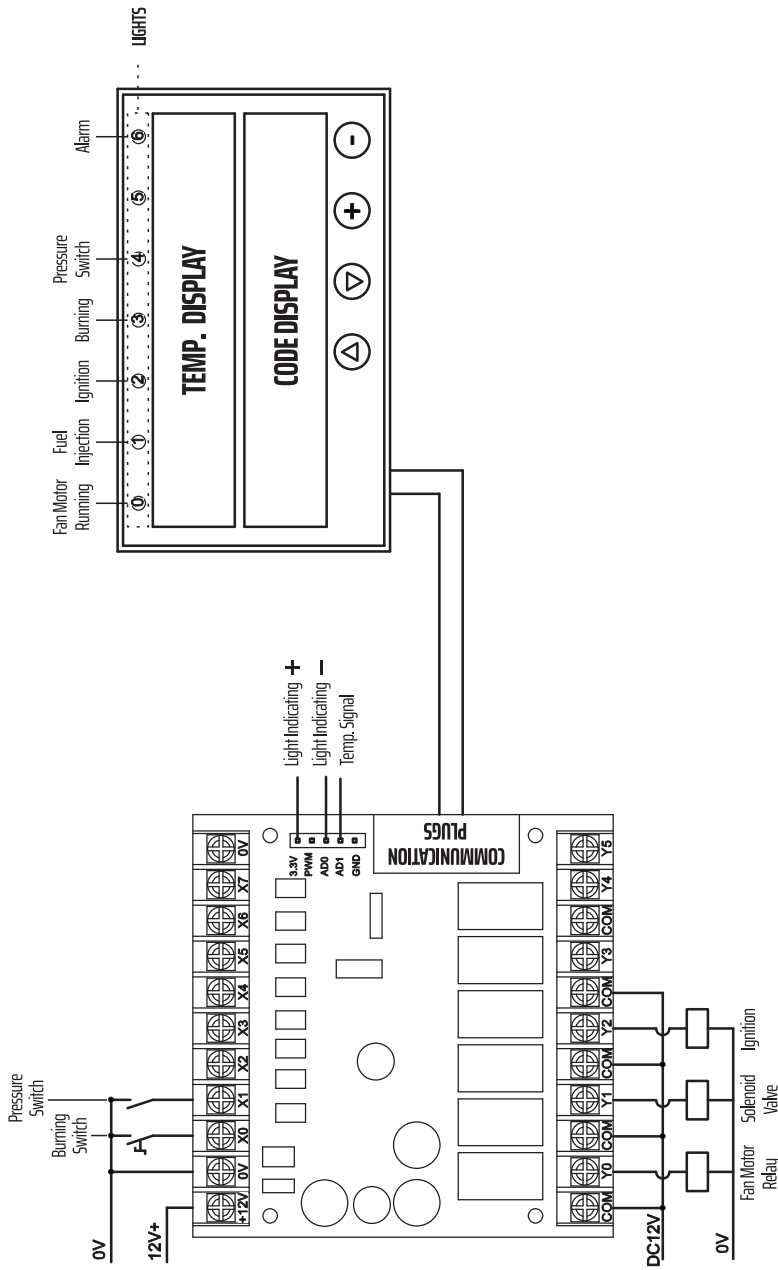

IMPORTANT! SAFETY FIRST!

Before attempting to use this product(s) please read all of the safety precautions and operating instructions outlined in this manual to reduce the risk of damage to the products and personal injury.