

**SEGATRICE A NASTRO PER METALLI FERROSI
BAND SAW FOR FERROUS METALS
BANDSAEGEMASCHINE FÜR EISENMETALLE
SCIE A RUBAN POUR METAUX FERREUX
SIERRA DE CINTA PARA METALES FERROSOS
ЛЕНТОЧНЫЙ РАСПИЛОВОЧНЫЙ СТАНОК ДЛЯ МЕТАЛЛОВ**

**MANUALE DI ISTRUZIONI PER L'USO - INSTRUCTION MANUAL FOR OPERATION
BETRIEBSANLEITUNG - MANUEL D'INSTRUCTIONS POUR L'EMPLOI
MANUAL DE INSTRUCCIONES DE USO
РУКОВОДСТВО ПО ЭКСПЛУАТАЦИИ И ТЕХОБСЛУЖИВАНИЮ**

**COSTRUTTORE:
MANUFACTURER:
ERBAUER:
CONSTRUCTEUR:
CONSTRUCTOR:
ИЗГОТОВИТЕЛЬ:**

MACC s.r.l. SCHIO (VI) - ITALY

**MODELLO:
MODEL:
MODELL:
MODELE:
MODELO:
МОДЕЛЬ:**

SPECIAL 411 AG

**MATRICOLA:
SERIAL NUMBER:
KENNNUMMER:
MATRICULE:
MATRICULA:
СЕРИЙНЫЙ НОМЕР:**

**ANNO DI COSTRUZIONE:
YEAR OF CONSTRUCTION:
BAUJAHR:
ANNEE DE CONSTRUCTION:
AÑO DE COSTRUCCION:
ГОД ИЗГОТОВЛЕНИЯ:**

2026





**DICHIARAZIONE DI CONFORMITA' 'CE'
CERTIFICATE OF CONFORMITY 'EEC'
KONFORMITÄTSBESCHEINIGUNG 'EWG'
DECLARATION DE CONFORMITE 'CE'
DECLARACION DE CONFORMIDAD 'CE'
ДЕКЛАРАЦИЯ О СООТВЕТСТВИИ 'CE'**

**MACC Costruzioni Meccaniche s.r.l. - Via Lago di Albano, 10 - 36015 Schio (VI) Italy
Tel.: 0445/575005 Fax: 0445/575006 Web site: www.macc.it E-mail: info@macc.it**

- Dichiara, sotto la propria responsabilità, che la macchina nuova descritta in appresso:
- Declares, by its own undertaking, that the new machine described below:
- Erklärt auf eigene Verantwortung, daß die nachstehend beschriebene neue Maschine:
- Déclare sous sa propre responsabilité, que la machine neuve décrite de suite:
- Declara, bajo la propia responsabilidad, que la nueva máquina descrita a continuación:
- Заявляет под личную ответственность, что описанная новая машина под названием:

**SEGATRICE A NASTRO PER METALLI
BAND SAW MACHINE FOR METALS
BANDSAEGEMASCHINE FÜR EISENMETALLE
SCIE A RUBAN POUR METAUX
SIERRA DE CINTA PARA METALES
ЛЕНТОЧНЫЙ РАСПИЛОВОЧНЫЙ СТАНОК ДЛЯ МЕТАЛЛОВ**

TIPO - TYPE - TYP - TYPE – TIPO - ТИП

SPECIAL 411 AG

MATRICOLA - SERIAL NUMBER - KENNNUMMER - MATRICULE – MATRICULA - СЕРИЙНЫЙ НОМЕР

**ANNO DI COSTRUZIONE – YEAR OF CONSTRUCTION - BAUJAHR – ANNEE DE CONSTRUCTION
AÑO DE COSTRUCCION - ГОД ИЗГОТОВЛЕНИЯ**

2026

- E' CONFORME ALLA DIRETTIVA MACCHINE 2006/42/CE, ALLA DIRETTIVA COMPATIBILITA' ELETTROMAGNETICA 2014/30/UE ED ALLA DIRETTIVA BASSA TENSIONE 2014/35/UE.
- IS IN COMPLIANCE WITH THE 2006/42/EEC MACHINERY DIRECTIVE, 2014/30/UE DIRECTIVE ON ELECTROMAGNETIC COMPATIBILITY, 2014/35/UE LOW VOLTAGE DIRECTIVE.
- DEN NORMEN BEZÜGLICH DER MASCHINEN-RICHTLINIE 2006/42/EWG, 2014/30/EWG RICHTLINIE ZUR ELEKTROMAGNETISCHEN KOMPATIBILITÄT, 2014/35/EWG RICHTLINIE FÜR NIEDERSpannung ENTSPRICHT.
- EST CONFORME A LA DIRECTIVE MACHINES 2006/42/CEE, 2014/30/CEE DIRECTIVE SUR LA COMPATIBILITÉ ÉLECTROMAGNÉTIQUE, 2014/35/CEE DIRECTIVE BASSE TENSION.
- HA SIDO FABRICADA CONFORME A LA DIRECTIVA MÁQUINAS 2006/42/CEE, 2014/30/CEE DIRECTIVA COMPATIBILIDAD ELECTROMAGNÉTICA, 2014/35/CEE DIRECTIVA BAJA TENSION.
- ОТВЕЧАЕТ ТРЕБОВАНИЯМ ДИРЕКТИВЫ ПО МАШИНАМ 2006/42/СЕ, ДИРЕКТИВЫ ОБ ЭЛЕКТРОМАГНИТНОЙ СОВМЕСТИМОСТИ 2014/30/СЕ И ДИРЕКТИВЫ О НИЗКОМ НАПРЯЖЕНИИ 2014/35/СЕ.

Nome della persona autorizzata a costituire il 'Fascicolo Tecnico' - Name of the person authorized to represent the 'Technical File' - Name der Person, auf die "Technical File" vertreten - Nom de la personne autorisée à représenter le 'dossier technique' - Nombre de la persona autorizada para representar a la "Ficha Técnica" - Фамилия, имя лица, уполномоченного составить техническую документацию

Macc Costruzioni Meccaniche s.r.l.

MACC Costruzioni Meccaniche s.r.l. - Via Lago di Albano, 10 – 36015 Schio (VI) Italy Tel.: 0445/575005 Fax: 0445/575006

Nome del Rappresentante Legale - Name of the Legal Representative - Name des Gesetzlichen Vertreters
Nom du Représentant Légal - Apellido del Representante Legal - Фамилия, имя законного представителя:

Zanella Gianfranco

MACC Costruzioni Meccaniche s.r.l. - Via Lago di Albano, 10 – 36015 Schio (VI) Italy Tel.: 0445/575005 Fax: 0445/575006

Firma - Signature - Unterschrift - Signature - Firma - Подпись:

Schio,

2026



E' SEVERAMENTE VIETATO UTILIZZARE LA MACCHINA SENZA LIQUIDO DI TAGLIO.

IT IS STRICTLY FORBIDDEN TO USE THE MACHINE WITHOUT CUTTING FLUID.

ES IST STRENG VERBOTEN, DIE MASCHINE OHNE SCHNEIDFLÜSSIGKEIT IN BETRIEB ZU NEHMEN.

IL EST SEVEREMENT INTERDIT D'UTILISER LA MACHINE SANS LIQUIDE DE COUPE.

SE PROHÍBE TERMINANTEMENTE UTILIZAR LA MÁQUINA SIN LÍQUIDO DE CORTE.

É SEVERAMENTE PROIBIDO UTILIZAR A MÁQUINA SEM LÍQUIDO DE CORTE.

Категорически запрещена эксплуатация машины без смазочно-охлаждающей жидкости



SISTEMA DI MICROLUBRIFICAZIONE: SE INSTALLATO SULLA MACCHINA, È OBBLIGATORIO L'USO DI MASCHERINA PROTETTIVA DELLE VIE AEREE. SI CONSIGLIA DI MANTENERE AREATO IL LOCALE.

MICRO-LUBRICATION SYSTEM: IF INSTALLED ON THE MACHINE, THE USE OF **PPE** (AIRWAYS PROTECTION MASK) IS NECESSARY. KEEP THE PLACE AERATED.

MIKRODOSIERGERÄT: FÜR MASCHINEN MIT MIKRODOSIERGERÄT IST ES STRIKT ERFORDERLICH EINE ATEMMASKE ZUM SCHUTZ DER ATEMWEGE ZU TRAGEN. BITTE DAS GERÄT NUR IN GUT BELÜFTETEN RÄUMEN ANWENDEN.

SYSTÈME DE MICRO-LUBRIFICATION: SI LE SYSTÈME EST INSTALLÉ SUR LA MACHINE, IL EST IMPÉRATIF DE PORTER UN MASQUE DE PROTECTION POUR PROTÉGER LES VOIES RESPIRATOIRES. LES LOCAUX DOIVENT ÉGALEMENT ÊTRE VENTILÉS.

SISTEMA DE MICROLUBRICACIÓN: SI ESTÁ INSTALADO EN LA MÁQUINA, ES OBLIGATORIO EL USO DE UNA MÀSCARA PROTECTORA DE LAS VÍAS RESPIRATORIAS. ES ACONSEJABLE MANTENER LA SALA VENTILADA.

SISTEMA DE MICRO-LUBRIFICAÇÃO: SE INSTALADO NA MÁQUINA, O USO DE UMA MÁSCARA PROTETORA DAS VIAS AÉREAS É OBRIGATÓRIO. É ACONSELHÁVEL MANTER O LOCAL VENTILADO.

СИСТЕМА МИКРОСМАЗКИ: ЕСЛИ СИСТЕМА УСТАНОВЛЕНА, ОБЯЗАТЕЛЬНО ИСПОЛЬЗОВАТЬ ЗАЩИТНУЮ МАСКУ И ПРОВЕТРИВАТЬ ПОМЕЩЕНИЕ.

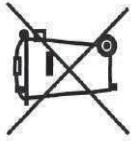

Felhasználható az Európai Unió és egyéb európai országok szelektív hulladékgyűjtési rendszereiben)

Ez a szimbólum a készülékek vagy a csomagolásán azt jelzi, hogy a terméket ne kezelje háztartási hulladékként. Kérjük, hogy az elektronikus és elektronikai hulladék gyűjtésére kijelölt gyűjtőhelyen adja le. A feleslegessé vált termékek helyes kezelésével segít megelőzni a környezeti és az emberi egészség károsodását, mely bekövetkezhetne, ha nem követi a hulladék kezelés helyes módját. Az anyagok újrahasznosítása segít a természeti erőforrások megőrzésében. A termék újrahasznosítása érdekében további információkat forduljon a kiskereskedőhöz, a helyi hulladékgyűjtő szolgáltatóhoz vagy ahhoz az üzlethez, ahol a terméket megvásárolta.

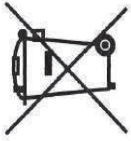

Nakládání s nepotřebným elektrickým a elektronickým zařízením (platné v Evropské unii a dalších evropských státech uplatňujících oddělený systém sběru)

Tento symbol umístěný na výrobku nebo jeho balení upozorňuje, že s výrobkem po ukončení jeho životnosti by nemělo být nakládáno jako s běžným odpadem z domácnosti. Místo toho by měl být odděleno do zvláštního místa, určeného k recyklaci elektrických výrobků a zařízení. Dodržení této instrukce zabrání negativnímu dopadu na životní prostředí a zdraví lidí, které naopak může být ohroženo nesprávným nakládáním s výrobkem při jeho likvidaci. Recyklováním materiálů, z nichž je vyroben, pomůžete zachovat přírodní zdroje. Pro získání dalších informací o recyklaci tohoto výrobku kontaktujte, prosím, místní orgány státní správy, místní firmu zabezpečující likvidaci a sběr odpadu nebo prodejnu, v níž jste výrobek zakoupili.

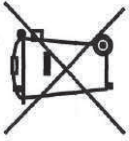

Likvidácia starých elektrických a elektronických zariadení (Platí v Európskej únii a ostatných európskych krajinách so zavedeným separovaným zberom)

Tento symbol na výrobku alebo obale znamená, že s výrobkom nemôže byť nakladané ako s domovým odpadom. Miesto, tohto je potrebné ho doručiť do vyhradeného zberného miesta na recykláciu elektrozariadení. Tým, že zaisíte správnu zneškodnenie, pomôžete zabrániť potenciálnemu negatívnu vplyvu na životné prostredie a ľudské zdravie, ktoré by v opačnom prípade hrozil pri nesprávnom nakladaní s týmto výrobkom. Recyklácia materiálov pomôha uchovávať prírodné zdroje. Pre získanie ďalších podrobných informácií o recyklácii tohoto výrobku kontaktujte prosím váš miestny alebo obecný úrad, miestnu službu pre zber domového odpadu alebo predajňu, kde ste výrobok zakúpili.

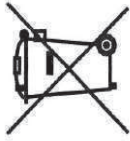

Eski Elektrikli & Elektronik Ekipmanların Atılması (Avrupa Birliği'nde ve aynı toplama sistemlerine sahip diğer Avrupa ülkelerinde uygulanır)

Ürün veya ambalajı üzerindeki bu sembol, bu ürünün bir ev atığı olarak muamele görmemesi gerektirir. Ürün, elektrikli ve elektronik ekipmanların geri dönüşümü için mevcut olan uygun toplama noktasına teslim edilmelidir. Bu ürünün doğru şekilde atılmasını sağlayarak, bu ürüne yanlış müdahale edilmemesi konusunda ortaya çıkabilecek ve çevre ile insan sağlığı üzerindeki olumsuz etkilerde bulunabilecek durumların önlenmesine yardımcı olursunuz. Malzemenin geri dönüşümü, doğal kaynakları korumamıza yardımcı olacaktır. Bu ürünün geri dönüşümüne ilgili daha fazla bilgi için, lütfen sehirinizde bulunan yerel ofisler, evsel atıklar toplama servisimize veya bu ürünü satın aldığınız mağazaya temasa geçin.

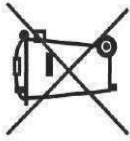

Oddaja stare električne in elektronske opreme (veljavno v evropski uniji in ostalih evropskih državah s sistemom zbiranja ločenih odpadkov)

Če se na izdelku ali na njegovi embalaži nahaja ta simbol, pomeni, da z izdelkom ne smete ravnati enako kot z drugimi gospodinjstvenimi odpadki. Morate ga oddati na ustrezno zbirno mesto za recikliranje električne in elektronske opreme. S pravilno oddajo tega izdelka boste pomagali preprečiti negativne posledice na okolje in zdravje ljudi, do katerih bi prišlo v primeru neustreznega ravnanja ob odstranitvi tega izdelka. Recikliranje materiala bo pripomoglo k ohranjanju naravnih virov. Podrobnejše informacije o recikliranju tega izdelka lahko dobite pri lokalni mestni upravi, službi oddajanja gospodinjstvenih odpadkov ali v trgovini, kjer ste izdelek kupili. Odpadno električno in elektronsko opremo lahko oddate brezplačno tudi distributerju neposredno ob dobavi električne oz. elektronske opreme.

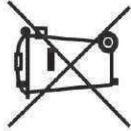

Утилизация электрического и электронного оборудования (директива применяется в странах Евросоюза и других европейских странах, где действуют системы раздельного сбора отходов)

Данный знак на устройстве или его упаковке обозначает, что данное устройство нельзя утилизировать вместе с прочими бытовыми отходами. Его следует сдать в соответствующий приемный пункт переработки электрического и электронного оборудования. Неправильная утилизация данного изделия может привести к потенциально негативному влиянию на окружающую среду и здоровье людей, поэтому для предотвращения подобных последствий необходимо выполнить специальные требования по утилизации этого изделия. Переработка данных материалов поможет сохранить природные ресурсы. Для получения более подробной информации о переработке этого изделия обратитесь в местные органы городского управления, службу сбора бытовых отходов или в магазин, где было приобретено изделие.

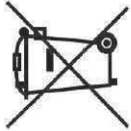

Käytöstä poistettujen sähkö- ja elektroniikkalaitteiden hävitys (Euroopan Unioni ja muiden Euroopan maiden keräysjärjestelmät)

Symboli, joka on merkitty Tuotteeseen tai sen pakkaukseen, osoittaa, että tätä tuotetta ei saa käsitellä tavallisten kotien jätteenä. Tuote on sen sijaan luovutettava sopivaan sähkö- ja elektroniikkalaitteiden kierrätyksellä huolehtivaan keräyspisteeseen. Tämän tuotteen asianmukaisen hävittämisen varmistamisella autetaan estämään sen mahdolliset ympäristöön ja terveyteen kohdistuvat haittavaikutukset, joita voi aiheutua muussa tapauksessa tämän tuotteen epäsäännöllisestä jäte käsittelystä. Materiaalien kierrätyksellä säästää luonnonvaroja. Tarkempia tietoja tämän tuotteen kierrättämisestä saa paikallisesta kunnantalonistosta.

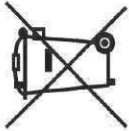

Bortskaffelse af elektrisk og elektronisk udstyr (gælder i EU og andre europæiske lande med egne indsamlingssystemer)

Hvis dette symbol findes på produktet eller på emballagen betyder det, at det pågældende produkt ikke må bortskaffes som almindeligt husholdningsaffald. Du skal i stedet aflevere det på et indsamlingssted, så det elektriske og elektroniske udstyr kan blive genbrugt. Når du bortskaffer produktet korrekt, hjælper du med at forhindre de mulige negative påvirkninger af miljøet eller sundheden, der kan opstå, hvis produktet bortskaffes på upassende vis. Genbrug af materialer er med at bevare naturlige ressourcer. Yderligere oplysninger om genbrug af produktet fås på kommunen, på genbrugscentralen eller i den butik, hvor du købte produktet.

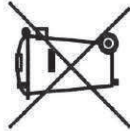

Tratamento de Equipamentos Eléctricos e Electrónicos no final da sua vida útil (Aplicável na União Europeia e em países Europeus com sistemas de recolha selectiva de resíduos)

Este símbolo, colocado no produto ou na sua embalagem, indica que este não deve ser tratado como resíduo urbano indiferenciado. Deve sim ser colocado num ponto de recolha, destinado a resíduos de equipamentos eléctricos e electrónicos. Assegurando-se que este produto é correctamente depositado, irá prevenir potenciais consequências negativas para o ambiente bem como para a saúde, que de outra forma poderiam ocorrer pelo mau manuseamento destes produtos. A reciclagem dos materiais contribui para a conservação dos recursos naturais. Para obter informação mais detalhada sobre a reciclagem deste produto, por favor contacte o município onde reside, os serviços de recolha de resíduos da sua área ou a loja onde adquiriu o produto.

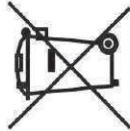

Αποκοπή Παλαιού Ηλεκτρικού & Ηλεκτρονικού Εξοπλισμού(Ισχύει στην Ευρωπαϊκή Ένωση και άλλες Ευρωπαϊκές χώρες με ξεχωριστά συστήματα περιουλοποίησης)

Το σύμβολο αυτό επάνω στο προϊόν ή στη συσκευασία του σημαίνει, ότι το προϊόν δεν πρέπει να πεταχτεί μαζί με τα οικιακά απορρίμματα αλλά πρέπει να παραδοθεί σε ένα κατάλληλο σημείο συλλογής ηλεκτρονικού και ηλεκτρικού υλικού προς ανακύκλωση. Με το να βεβαιωθείτε ότι το προϊόν πετάγεται σωστά, βοηθάτε στην πρόληψη πιθανών αρνητικών επιπτώσεων στο περιβάλλον και την υγεία. Η ανακύκλωση των υλικών θα βοηθήσει στην εξοικονόμηση φυσικών πόρων. Για περισσότερες πληροφορίες σχετικά με την ανακύκλωση αυτού του προϊόντος, παρακαλούμε επικοινωνήστε με τις υπηρεσίες καθαριότητας του δήμου σας ή το κατάστημα όπου αγοράσατε το προϊόν.

English

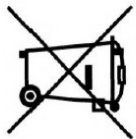

Disposal of Old Electrical & Electronic Equipment (Applicable in the European Union and other European countries with separate collection systems)

This symbol on the product or its packaging indicates that this product shall not be treated as household waste. Instead it shall be handed over to the applicable collection point for the recycling of electrical and electronic equipment. By ensuring this product is disposed of correctly, you will help prevent potential negative consequences for the environment and human health, which could otherwise be caused by inappropriate waste handling of this product. The recycling of materials will help to conserve natural resources. For more detailed information about recycling of this product, please contact your local city office, your household waste disposal service or the shop where you purchased the product.

Français

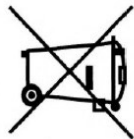

Traitement des appareils électriques et électroniques en fin de vie (Applicable dans les pays de l'Union Européenne et aux autres pays européens disposant de systèmes de collecte sélective)

Ce symbole, apposé sur le produit ou sur son emballage, indique que ce produit ne doit pas être traité avec les déchets ménagers. Il doit être remis à un point de collecte approprié pour le recyclage des équipements électriques et électroniques. En s'assurant que ce produit est bien mis au rebut de manière appropriée, vous aidez à prévenir les conséquences négatives potentielles pour l'environnement et la santé humaine. Le recyclage des matériaux aidera à conserver les ressources naturelles. Pour toute information supplémentaire au sujet du recyclage de ce produit, vous pouvez contacter votre municipalité, votre déchetterie ou le magasin où vous avez acheté le produit.

Deutsch

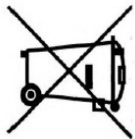

Entsorgung von gebrauchten elektrischen und elektronischen Geräten (Anzuwenden in den Ländern der Europäischen Union und anderen europäischen Ländern mit einem separaten Sammelssystem für diese Geräte)

Das Symbol auf dem Produkt oder seiner Verpackung weist darauf hin, dass dieses Produkt nicht als normaler Haushaltsabfall zu behandeln ist, sondern an einer Annahmestelle für das Recycling von elektrischen und elektronischen Geräten abgegeben werden muss. Durch Ihren Beitrag zum korrekten Entsorgen dieses Produkts schützen Sie die Umwelt und die Gesundheit Ihrer Mitmenschen. Umwelt und Gesundheit werden durch falsches Entsorgen gefährdet. Materialrecycling hilft den Verbrauch von Rohstoffen zu verringern. Weitere Informationen über das Recycling dieses Produkts erhalten Sie von Ihrer Gemeinde, dem kommunalen Entsorgungsbetrieb oder dem Geschäft, in dem Sie das Produkt gekauft haben.

Español

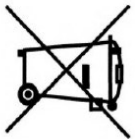

Tratamiento de los equipos eléctricos y electrónicos al final de su vida útil (Aplicable en la Unión Europea y en países europeos con sistemas de recogida selectiva de residuos)

Este símbolo en su equipo o su embalaje indica que el presente producto no puede ser tratado como residuos domésticos normales, sino que deben entregarse en el correspondiente punto de recogida de equipos eléctricos y electrónicos. Asegurándose de que este producto es desechado correctamente, Ud. está ayudando a prevenir las consecuencias negativas para el medio ambiente y la salud humana que podrían derivarse de la incorrecta manipulación de este producto. El reciclaje de materiales ayuda a conservar las reservas naturales. Para recibir información detallada sobre el reciclaje de este producto, por favor, contacte con su ayuntamiento, su punto de recogida más cercano o el distribuidor donde adquirió el producto.

CALIFORNIA PROPOSITION
65 WARNING

WARNING: This product contains chemicals known to the State of California to cause cancer and birth defects or other reproductive harm.

For more information: www.P65Warnings.ca.gov

Nederlands

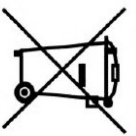

Verwijdering van Oude Elektrische en Elektronische Apparaten (Toepasbaar in de Europese Unie en andere Europese landen met gescheiden opnamestelsel)

Het symbool op het product of op de verpakking wijst erop dat dit product niet als huishoudafval mag worden behandeld. Het moet echter naar een plaats worden gebracht waar elektrische en elektronische apparatuur wordt gerecycled. Als u ervoor zorgt dat dit product op de correcte manier wordt verwerkt, voorkomt u mogelijk voor mens en milieu negatieve gevolgen die zich zouden kunnen voordoen in geval van verkeerde afvalbehandeling. De recycling van materialen draagt bij tot het vrijwaren van natuurlijke bronnen. Voor meer details in verband met het recyclen van dit product, neemt u het best contact op met de gemeentelijke instanties, het bedrijf of de dienst belast met de verwijdering van huishoudafval of de winkel waar u het product hebt gekocht.

Svenska

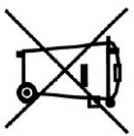

Omhändertagande av gamla elektriska och elektroniska produkter (Användbar i den Europeiska Unionen och andra Europeiska länder med separat insamlingsssystem)

Symbolen på produkten eller emballaget anger att produkten inte får hanteras som hushållsavfall. Den skall i stället lämnas in på uppsamlingsplats för återvinning av el- och elektronikkomponenter. Genom att säkerställa att produkten hanteras på rätt sätt bidrar du till att förebygga eventuellt negativa miljö- och hälsoeffekter som kan uppstå om produkten kasseras som vanligt avfall. Återvinning av material hjälper till att bibehålla naturens resurser. För ytterligare upplysningar om återvinning bör du kontakta lokala myndigheter eller sophanterningsföretag eller affären där du köpte varan.

Italiano

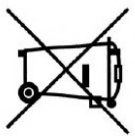

Trattamento del dispositivo elettrico ed elettronico a fine vita (Applicable in tutti i paesi dell'Unione Europea e in quelli con sistema di raccolta differenziata)

Questo simbolo sul prodotto o sulla confezione indica che il prodotto non deve essere considerato come un normale rifiuto domestico, ma deve invece essere consegnato ad un punto di raccolta appropriato per il riciclo di apparecchi elettrici ed elettronici. Assicurandosi che questo prodotto sia smaltito correttamente, voi contribuite a prevenire potenziali conseguenze negative per l'ambiente e per la salute che potrebbero altrimenti essere causate dal suo smaltimento inadeguato. Il riciclaggio dei materiali aiuta a conservare le risorse naturali. Per informazioni più dettagliate circa il riciclaggio di questo prodotto, potete contattare l'ufficio comunale. Il servizio locale di smaltimento rifiuti oppure il negozio dove l'avevo acquistato.

Język polski

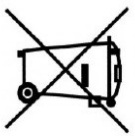

Pozbycie się Zużytego Sprzętu (Stosowane w krajach Unii Europejskiej i w pozostałych krajach europejskich mających własne systemy zbiorcze)

Taki symbol na produkcie lub jego opakowaniu oznacza, że produkt nie może być traktowany jako odpad komunalny, lecz powinno się go dostarczyć do odpowiedniego punktu zbiórki sprzętu elektrycznego i elektronicznego, w celu recyklingu. Poprzez upewnienie się, że zużyty sprzęt dołączony do produktu jest poprawnie zapakowany, pomagamy w tym samym czasie w redukowaniu szkodliwych odpadów i ochronie naturalnych źródeł. W celu uzyskania bardziej szczegółowych informacji na temat recyklingu tego produktu, należy skontaktować się z naszym lokalnym biurom, ze służbami oczyszczania miasta lub ze sklepem, w którym zakupiony został ten produkt.

Norsk

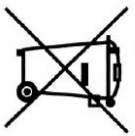

Avhending av gamle elektriske og elektroniske apparater (gjelder i EU og andre europeiske land med separat innsamlingsystem)

Dette symbolet på produktet eller innpakningen indikerer at dette produktet ikke må håndteres som husholdningsavfall. I stedet skal det leveres inn til spesielle innsamlingspunkter for gjenvinning av det elektriske og elektroniske utstyret. Ved å sørge for at dette produktet avhendes på korrekt måte, vil du hjelpe til med å forhindre potensielle negative påvirkninger på miljøet og helse, som ellers kan være resultatet av feilaktig avfallshåndtering av dette produktet. Gjenvinning av disse materialene vil hjelpe til med å la være på våre naturressurser. For mer informasjon om gjenvinning av dette produktet, kan du kontakte lokale myndigheter.

1. INTRODUCTION

This operation instruction manual conforms to the requirements of the Machine Directive 2006/42/EEC . In this light , special attention has been given to safety aspects and accident prevention in the work-place for each stage in the machine's "life" . Information which could be of particular assistance to the operator has been highlighted .

The "Operating instructions" are an integral part of the machine and should be consulted before , during and after the start up of the machine and whenever else required . The content of these instructions should always be carefully observed .

The observance of the above is the only way to achieve the two fundamental aims of this manual :

- **Optimization of machine performance**
- **Prevent damage to the machine and injury to the operator**

The index of the chapters and the index of the drawings , diagrams and tables is contained in chapter 3 and can be used to help the location of specific information .

CAUTION : BEFORE INSTALLING THE MACHINE , READ THE OPERATING INSTRUCTIONS CAREFULLY
--

2. INFORMATION ABOUT MAINTENANCE ASSISTANCE

2.1 GUARANTEE

- MACC S.r.l. products are guaranteed against material and manufacturing defects for a period of 12 months from the date of delivery or , if the machine is installed by MACC employees , from the date of machine start up .
- The buyer is only entitled to the replacement of parts which are acknowledged as faulty : carriage and packing are at the buyer's expense . In the event of the above , the following information should be supplied :
 1. Date and number of purchasing document
 2. Machine model
 3. Serial number
 4. Code of any relevant drawings
- Requests for compensation for the inactivity of the machine will not be accepted .
- The guarantee does not cover uses which are not in line with these operating instructions which are an integral part of the machine . Nor is maintenance covered if the instructions supplied are not observed .
- The guarantee will not cover machines which have undergone unauthorized modifications .
- Modification or tampering with the safety devices is strictly forbidden .

3. INDEX

3.1 INDEX OF CHAPTERS

Chap 1	Introduction
Chap 2	Information about maintenance assistance
Chap 3	Index of chapters , drawings , diagrams and tables
Chap 4	Description of the machine Safety standards complied with during the design and construction of the machine Description of the machine and its components Intended and unsuitable uses of the machine
Chap 5	Main technical data
Chap 6	Handling and transportation
Chap 7	Installation
Chap 8	Start up and operation Devices and their location Tools supplied Operation Special safety checks General safety rules Measures to prevent residual risks Safety , Guidance , Notice Labels on the Machine
Chap 9	Maintenance and repairs General safety measures Routine checks and maintenance Description of routine maintenance Possible inconveniences
Chap 10	Information regarding environmental noise
Chap 11	Laying off - Demolition
Chap 12	List of spare parts

3.2 INDEX OF DRAWINGS , DIAGRAMS AND TABLES

ENCL. TYPE	DESCRIPTION	ENCL No.
Table	Cutting capacity - Selection of blade - Cutting speeds	1-2
Drawings	Handling and transportation - Installation plan	3-4
Drawings	Base	5
Drawings	Bench	6
Drawings	Vice	7
Drawings	Rotating arm	8
Drawings	Bow - Blade guide	9-10
Drawings	Carriage	11-12
Drawings	Control panel	13
Drawings	Carriage feed system	14
Drawings	Rotation motor	15
Drawings	Roller arm	16
Diagram	Wiring diagram	

4. DESCRIPTION OF THE MACHINE

4.1 SAFETY STANDARDS COMPLIED WITH DURING THE DESIGN AND CONSTRUCTION OF THE MACHINE

The machine produced by us is in compliance with :

- **2006/42/EEC Machinery Directive .**

The following Standards apply :

- EN ISO 12100 Safety of machinery - Basic concepts and general principles for design .
Basic terminology and methods .
- EN ISO 16093 Safety of machinery . Basic concepts and general principles for design .
Specifications and technical principles .
- EN ISO 13850 Safety of machinery . Emergency stop devices , functional aspects - design principles .
- EN ISO 4413-14 Safety requirements related to systems and components for hydraulics and pneumatic transmissions .
- EN 1037 Safety of machinery. Isolation and energy dissipation . Prevention of unexpected start-up .
- EN 14119 Safety of machinery - Interlocking devices with and without guard – locking . General principles and provisions for design .
- EN 60204-1 Safety of machinery . Electrical equipment of machines . Part 1 : General requirements Sa
- EN 13857 Safety of machinery . Safety distances to prevent danger zones being reached by the upper limbs .

- **2014/30/UE Directive on electromagnetic compatibility .**

The following Standards apply :

- EN 55014-1 Electromagnetic compatibility - Requirements for household appliances , electric tools and similar apparatus .
- EN 61000-3-2 Electromagnetic compatibility (EMC) -- Part 3-2 : Limits - Limits for harmonic current emissions .
- EN 61000-3-11 Electromagnetic compatibility (EMC) -- Part 3-11: Limits - Limitation of voltage changes , voltage fluctuations and flicker in public low-voltage supply systems .
- EN 55032 Electromagnetic compatibility of multimedia equipment - Emission requirements .
- EN 61000-4-2 Electromagnetic compatibility (EMC) -- Part 4-2 : Testing and measurement techniques – Electrostatic discharge immunity test
- EN 61000-4-4 Electromagnetic compatibility (EMC) -- Part 4-4 : Testing and measurement techniques - Electrical fast transient/burst immunity test
- EN 61000-4-6 Electromagnetic compatibility (EMC) -- Part 4-6 : Testing and measurement techniques – Immunity to conducted disturbances , induced by radio-frequency fields

- **Low Voltage Directive 2014/35/UE .**

Directive 2003/11/EC Directive 2003/11/EC of the European Parliament and of the Council of 6 February 2003 amending for the 24th time Council Directive 76/769/EEC relating to restrictions on the marketing and use of certain dangerous substances and preparations (pentabromodiphenyl ether , octabromodiphenyl ether)

Directive 2002/44/EC of the European Parliament and of the Council of 25 June 2002 on the minimum health and safety requirements regarding the exposure of workers to the risks arising from physical agents (vibration) (sixteenth individual Directive within the meaning of Article 16 (1) of Directive 89/391/EEC) .

4.2 DESCRIPTION OF THE MACHINE AND ITS COMPONENTS

The Special-411-AG band sawing machine produced by MACC has a sturdy frame made from welded and painted sheet-steel . The upper surface is designed to allow the complete draining away of the cutting fluid. The band support bow is made in cast iron , with a suitable dimension to provide the necessary stiffness and precision to the cutting unit . The vice unit is made of cast-iron and clamps the material to be cut securely . The numerical control device allows the required length to be present and provides high repeated-cut precision .

The bar-stop device allows setting a desired length and a remarkable accuracy with repetitive cutting in manual/semiautomatic. The bow is firmly connected to a reduction unit attached to the motor and to the bottom casting by a hinge allowing a automatic rotation 45° right – 45° left and the cutting movement in automatic with hydraulic cylinder.

The coolant pump is fitted to the machine base. A electromechanical device with pressure switch for band tightening , prevents the band from advancing in the event of insufficient tension and moreover allows ideal operation conditions to be restored at any moment . The main switch is located on the front panel . The blade is protected by a guard with interlock which covers the upper area and the handwheels and by two adjustable lower guards which protect the operator from ejected shavings and coolant . The machine is supplied with a set of service spanners and rod support .

4.3 INTENDED AND UNSUITABLE USES OF THE MACHINE

The SPECIAL-411-AG band sawing machine has been designed and built to cut bars , structural steel and ferrous metal pipes in accordance with the instructions contained in this manual . Therefore , the cutting of other materials is not permitted : if the above recommendations are not observed , the machine could be damaged and the health and safety of the operator put at risk . Cutting is not permitted , if the bar has not been first locked in the vice .

5. MAIN TECHNICAL DATA

Under no circumstances should the following data be altered , this is in order to protect the correct functioning of the machine and to avoid creating safety risks for the operator .

Three phase power supply	
Motor power	2,2 kW
Motor revolutions	1430 rpm
Cutting speed (Inverter)	0-90 m/1'
Control unit motor	0.55 kW
Electric pump	0.09 kW
Fly wheel dimensions	350 mm
Blade size (length x width x thick)	3200 x 27 x 0.9 mm
Cutting thickness	1,2 mm
Cutting angle	45° dx - 45° sx
Material clamping vice max opening	300 mm
Jaws height	150 mm
Bed height	850 mm
Coolant tank capacity	50 litri
Machine weight	~13820 N (1410 kg~)

6. HANDLING AND TRANSPORTATION

For safe handling and transportation use a lift truck for movement indoors ENCL.3 . Keep the machine in its normal position .

All handling and transportation operations should be carried out by trained staff .

7. MACHINE INSTALLATION

A. MACHINE CHECK

The machine should be checked to make sure that it has not been damaged during transportation and handling . If the machine appears to have been damaged , contact MACC immediately .

B. FASTENING OF THE MACHINE

The machine will be able to operate in keeping with the technical parameters supplied by MACC if it is positioned correctly and fastened securely to the bench or the factory floor so that vibrations are minimal during operation . Consult drawing SPECIAL-411-AG . Installation plan ENCL.4 .

C. BAND ASSEMBLY

Remove the bow guard cod.056/42 by unscrewing the screws and the washers . Fit the band by inserting it first between the bearings of the blade guide heads and then on the two pulleys , tighten the blade slightly by means of the hand wheel cod.058/35 and replace the bow guard . Check that the band is fitted with the correct direction of teeth , as shown in enclosed document 9 . Make sure that the band type (dimensions 3200x27x0.9) and its teeth pitch are suited to the material to be cut .

D. ELECTRICAL CONNECTION TO THE MAINS

Install a differential thermomagnetic switch with characteristics suited to the mains .

Make sure that the power supply voltage corresponds to the voltage on the motor plate . Connect the cable to the power supply line observing the colour codes of the individual wires , pay particular attention to the earth wire . Connect the machine , make sure that the rotation of the circular blade is in the direction shown by the arrow on the guard .

E. CUTTING COOLANT

For the cooling of the circular blade, fill the tank with emulsion oil obtained from a mixture of water and ENI AQUAMET 700 EP oil with a percentage of 5-7%.

F. SPRING TENSIONING ADJUSTMENT

Wind the spring by turning screw up to 47 mm as shown in ENCL.8 .

8. MACHINE START UP AND OPERATION

8.1 DEVICES AND THEIR LOCATION

(The location of the devices described is shown on the SPECIAL-411-AG installation plan) .

Cod. 314/90	LOCKABLE MAIN SWITCH
Cod. 089/90	ELECTRIC PUMP
Cod. 085/90	EMERGENCY BUTTON
Cod. 145-C/36	ROLLER CONVEYOR
Cod. 011/44	LOCKING VICE
Cod. 824/46	CYLINDER FIXED VICE
Cod. 059/36	CYLINDER VICE CARRIER
Cod. 149/37	CYLINDER BOW

8.2 TOOLS SUPPLIED

1	Allen wrench size 3
1	Allen wrench size 5
1	Allen wrench size 6
1	Allen wrench size 8
1	Allen wrench size 10

8.3 OPERATION

CHECKS TO CARRY OUT BEFORE EACH CUT

A. Tension the band by rotating the handwheel 058/35 till the end of the traverse . On the display does not blink the signaling "Broken Blade" . Remember at the end of the operation to loosen the hand wheel to avoid the slackening of the band .

B. Check that the hand indicates the required cutting angle (vice scale) .

C.

D. Stroke adjusting headband : follow the instructions of the manual tool TOP10 .

E. With the motor off , lower the bow and check that at the end of stroke , the band does not touch the rotating plate 26-A/42 . If the band does touch , adjust the screw located on the rotating plate (ENCL.8) . By adjusting screw , the width of the working stroke can also be established .

F. Make sure that the piece to be cut is properly secured in the vice ;

G. Make sure that the cooling liquid is circulating in the machine . Use the tap located on the guide shoe to regulate the flow of liquid .

H. When starting the motor , make sure that the band rotates in the direction of the arrow shown in ENCL. 9 .

I. To obtain maximum cutting accuracy , the unit must be located the nearest possible to the workpiece . Clamp the work piece with the vice , release the mobile blade guide plate 027-A/32 with screw and move it near the vice jaw so that it doesn't touch it during the cutting operation , then secure it again . When carrying out this operation , make sure that the blade guide guard does not come out of the bow guard leaving a part of the blade exposed .

CUTTING OPERATION

A. Before starting to cut , if the cutting inclination is not as required , correct it or change it by pulling the knob 103/11 and turning the rotating plate 026/42 until the required position is reached . If the position is not one of the normal set positions , fasten the rotating plate using the hand wheel 044/09 (ENCL.6) .

B. For other information regarding the cutting operation and machine programming , follow the supplied TOP10 instructions carefully .

C. To replace the band , carry out the same operations used to assemble the band (chapter 7c) .

D. For the choice of blade see table ENCL.1 .

ATTENTION!!!

-WE STRONGLY DISCOURAGE THE USE OF BLADES WITH RUINED OR INSUFFICIENTLY SHARP CUTTING EDGES .

-ON MACHINE WITH HYDRAULIC VERTICAL PRESSING , REMOVE THE ROLLER DEVICE FOR THE FRONT PACK CUTTING BEFORE MAKING CUTS AT 45°

8.4 SPECIAL SAFETY CHECKS

A. Before using the machine , check carefully that the safety devices are in good working order , that the mobile parts are not blocked , that no parts are damaged and that all the components are installed correctly and are functioning properly .

B. Make sure , before operating the machine , that the screws of the guards and other protective devices are adequately secured , especially the screws of the bow guard .

C. Check that the safety microswitches and the emergency button are functioning correctly . Test them during a loadless machine cycle .

D. Pay attention to environmental conditions . Do not expose the machine to rain ; to not use it in damp environments , position the machine on a clean dry floor that has no oil or grease stains .

E. Before using the machine , the operator should make sure that all tools and service spanners used for maintenance or adjustment have been removed .



8.5 GENERAL SAFETY RULES

- A. Wear appropriate clothing . The operator's clothing should not be loose or dangling nor should it have parts which could easily get caught . Sleeves should contain elastic . Belts , rings or chains should not be worn. Long hair should be kept in a net .
- B. Avoid unstable operating positions . Find a safe and evenly balanced position to operate the machine .
- C. Keep the work area tidy , untidiness increases the risk of accidents .
- D. Do not use the power supply cable to disconnect the plug from the socket . Protect the cable from high temperatures , oil or sharp edges . For outdoor use, only use extension cables which are in line with current regulations .

8.6 MEASURES TO PREVENT RESIDUAL RISKS

- A. The removal of guards and tampering with the safety devices is strictly forbidden .
- B. Gloves should always be worn .
- C. Standard work clothing should be used and kept closed and should not have flapping parts .
- D. The machine should not be cleaned with liquids under pressure .
- E. In the event of fire , extinguishers should not be used unless they are the powder type . The electric power supply to the machine should always be disconnected in these circumstances .
- F. Do not insert foreign bodies into the motor cover and to not supply the machine with voltage by tampering with the safety microswitches or main switch .
- G. Take the necessary precautions to avoid the machine being started by other people during loading , adjustment , piece changing or cleaning .

8.7 SAFETY , GUIDANCE , NOTICE LABELS ON THE MACHINE

		MACC Costruzioni Meccaniche S.r.l. Via Lago di Albano, 10 36015 Schio (VI) ITALY Tel. +39 0445 575001-05 Fax +39 0445 575006 Web site www.macc.it	
Modello - Model	Massa - Weight (Kg)		
Matricola - Serial number	Anno - Year		
 Centralina idraulica - Hydraulic unit: Eni Arnica 32 Scatola ingranaggi - Gearbox : Eni Blasia 220 Puntini a grasso - Grease points : Eni Grease MU EP 2			



- NON RIMUOVERE I DISPOSITIVI E LE PROTEZIONI DI SICUREZZA!
- BESCHERMKAPPEN EN BEVEILIGINGEN MOGEN NIET VERWIJDERD WORDEN !
- DO NOT REMOVE THE SAFETY DEVICES AND GUARDS !
- DIE SCHUTZVORRICHTUNGEN NICHT ENTFERNEN!
- NE PAS ENLEVER LES DISPOSITIFS ET LES PROTECTIONS DE SECURITE!
- NO QUITAR LOS DISPOSITIVOS Y LAS PROTECCIONES DE SEGURIDAD !

- METTERE IN TENSIONE LA LAMA RUOTANDO IL VOLANTINO FINO A FINE CORSA.
- PUT TENSION ON THE BLADE BY ROTATING THE HANDWHEEL TO THE END OF STROKE.
- DAS SÄGEBAND SPANNEN, INDEM DAS HANDRAD BIS ZUM ENDE GEDREHT WIRD.
- METTRE EN TENSION LA LAME EN TOURNANT LE VOLANT JUSQU'À LA FIN DE COURSE.
- TENSIONAR LA CINTA GIRANDO EL VOLANTE HASTA EL FINAL DE CARRERA.



**COLLEGATO
CONNECTED
400 VOLT**

**COLLEGATO
CONNECTED
480 VOLT**

9. MAINTENANCE AND REPAIRS

9.1 GENERAL SAFETY MEASURES

- A. Lockable main switch . Use the padlock in the event of machine failure or replacement of the band . The padlock key should be entrusted to a responsible person .
- B. Before carrying out any work on electrical equipment , remove the power supply plug from the control panel (disconnect voltage) .
- C. Only use cables to supply power , which have a cross-section suited to the power of the machine .

D. Opening key . The keys of the machine should be kept by authorized personnel . Do not leave the keys for doors which provide access to the hydraulic or electrical parts or keys to lockable switches in easy of reach of unauthorized personnel .

E. Repairs should only be carried out by authorized personnel . Only spare parts made by the original manufacturer should be used , otherwise these could cause damage or injury .

9.2 ROUTINE CHECKS AND MAINTENANCE

FREQUENCY (working hours)	OPERATION
1000 hours	Adjustment blade guide bearings
1000	Lubrication of mobile parts in the piece locking vice . (ENI GREASE MU EP 2)
1500	Blade drive reduction unit
50	Cleaning of the coolant tank and filter check
Monthly	Check oil in the control unit
if necessary	Add hydraulic unit oil with ENI ARNICA 32

9.3 Description of routine maintenance

A. Adjustment of the blade guide bearings

Loosen the screw , rotate the cams cod.027/35 , so that the blade guide bushings vertically position the blade in axis (ENCL.10) . Tighten the dowels until the blade secured . Loosen the dowels slightly (about 1/10 of a turn) . The front blade guide must be positioned as near as possible to the piece to be cut . Check every 3 months the existing tolerance between the blade guides , making sure that it does not exceed the blade thickness of one tenth of a millimetre , so as to avoid inexactnesses in the cut squaring . Periodically check with mounted blade that the blade guide bearings rotate freely .

B. Lubrication of mobile parts of piece locking vice

Lubricate the vice rod 827/46 using the grease gun . Clean and grease the mobile parts of the vice and rotating plate where indicated in the attached 6 – 7 - 8 . In case of sliding difficulties or play the clamp guides carry out the following operations : loosen nut , adjust dowel and secure .

C. Blade drive reduction unit

First oil change after 500 working hours , other changes after 1500 hours (ENI BLASIA 220) .

D. Cleaning of the coolant tank .

To clean the coolant tank , simply remove the tank with the filter which is situated at the back of the machine . Empty the coolant from the tank and collect the coolant in a container for future disposal . Clean away the shavings and the metallic powder , taking care not to scatter this over the machine especially around the motor and the box containing the electrical equipment . Fill the tank with the amount and liquid stated earlier .

E. Checking of bench lever functioning

Check regularly that the rotation release - locking lever is working properly .

F. Check oil in the control unit

Check the level oil in the control unit tank and add the amount necessary .

9.4 POSSIBLE INCONVENIENCES

A. Automatic cycle does not function

-If this cycle does not function , make sure that all the limit switches are energized .

B. Oblique cutting

Check the inclination of the blade using the comparator located near the saw blade guide and use the hexagon socket headless screws which regulate the saw blade guide , to reset the correct inclination .

C. Undulated - concave - convex cutting

-Make sure the blade is not worn .

-Adjust the blade rotation speed in relation to the material , using the speed selector (or the variator , if fitted) .

-Adjust the bow down stroke speed in relation to the material , using the cutting feed regulator .

-Check the exact alignment of the saw blade guide with the mobile guide in different positions (adjust the hexagon socket headless screws) .

10. INFORMATION REGARDING ENVIRONMENTAL NOISE

An environmental noise test carried out on the SPECIAL-411-AG band saw machine , identical to the machine to which these operation instructions refer , has given the following results :

ACOUSTIC RADIATION PRESSURE

1. $L_{Aeq} = 76,7 \text{ dB (A)}$

2. $L_{peak} = 82,7 \text{ dB}$ (the maximum acceptable value is 140 dB) .

3. The level of background noise has no influence = 48.5-54,2 dB (A)

The considerable data are the result of tests made under the D.lgs. 277/1991 in the implementation of the directives nr.

80/1107/CEE , nr. 82/605/CEE , nr.84/477/CEE , and 88/642/CEE .

11. LAYING OFF AND DISMANTLING

11.1 LAYING OFF

If the machine is to be laid off or left idle for a long period , the following operations must be carried out :

1. Disconnect the machine from the electricity mains .
2. Empty oil from the gear box and cooling liquid from its tank
3. Clean carefully the machine by getting rid of all traces of grease , especially on the worked parts that must be protected with anti-oxidants .
4. Cover the machine with a sheet , preferably not plastic as it can cause rust due to the humidity condensation .
5. Store the machine in a closed , dust-free place .

11.2 DISMANTLING

If the machine must be definitively dismantled , its components must be sub-divided for the purpose of a possible recycle of the materials and for the environment safety . The following table is given for your guidance :

Steel	Electrical Components	Light alloy	Cast iron	Bronze Copper	Plastic and rubber	Various
Shaft	Motors winding	Gear boxes	Structural parts	Bushings	Seals	
Rollers	Push button and Control system (relais – transformer)	Cylinders			Cable chain	
Base	Electronic panel					
Spring						

Used oil and materials must be disposed of according to 87/101/EEC Directives and to country specific regulations .

The disposal of electrical components is provided for by European Directives 2011/65/CEE .

Customer Company Name: MACC COSTRUZIONI MECCANICHE

Machine: SPECIAL 411 AG

Other Contacts: Mr Carlo - Mr. Mark

Control: TOP10

Software: New software / Touch 10"

(Soft) number: 0817

(Firm) number: 3116

Authors: ELCO.



Automatic Cutting Machine with angle cutting (TOP10)

<u>Automatic cutting machine TOP 12</u>	2
<u>Automatic cutting machine TOP 12</u>	2A
<u>General description of the project</u>	3
<u>Splash screen</u>	4
<u>Axis homing</u>	5
<u>Menù main</u>	6
<u>Manual cutting function</u>	7
<u>Machine set-up</u>	8
<u>Automatic cutting screen</u>	9
<u>Automatic cutting screen</u>	10
<u>General parameter</u>	11
<u>Alarm logs</u>	12
<u>To set high and low of the blade</u>	13
<u>Fulcrum settings</u>	14
<u>To change the fulcrum setting</u>	15
<u>Download updates</u>	16
<u>Test and connection setting</u>	17

General description of the project

The project includes the development of new software for the management of an automatic steel cutting machine that is composed of:

- advancement carriage (can be configured with Brushless or Inverter)
- angle cutting (can be enabled or disabled)
- automatic bar loader (enabled/disabled)
- cutting head height (with potentiometer or low FC + feeler)
- *end-machining laser option (to be developed at a later date)*
- *blade deviation management option (to be developed at a later date)*
- *proportional EV for arc down option (to be developed at a later date)*
- cutting optimizer (standard).

The following configuration is required in order to implement the application:

- 1 x TOP12 (integrated PLC/CNC/HMI);
- 1 x EC7COM_01 1 (power supply and communication board);
- 2 x EC7DIO_021 (16 + 16 digital I/O board);
- 2 x EC7AS_031 (board 2 encoder inputs + 2 analogue outputs)
- 1 x EC7AI_041 (board 8 analogue inputs + 2 analogue outputs)

Splash screen



At start-up the Splash screen will appear for 3 seconds showing the "MACC" logo with the information about the software and firmware version currently installed on the TOP10.

The axis homing screen will then appear.

Axis Homing

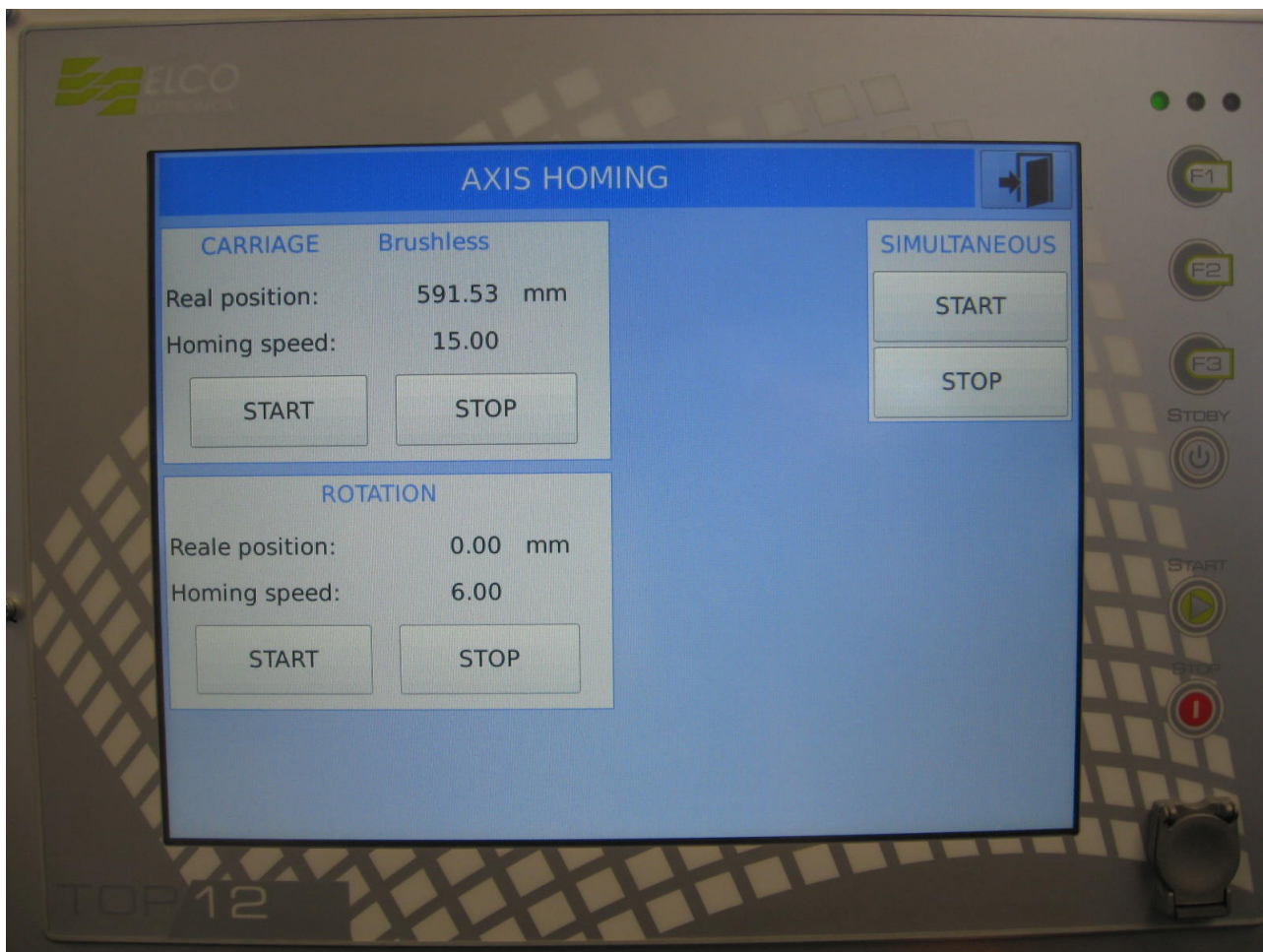

This screen will allow you to Reset both Axis of the machine together by pressing start, in the Simultaneous Box On the right hand side of the screen.

On the left-hand side of the screen you can find 2 separate start buttons, 1 for the carriage, 1 for the head position.

Note: The machine prior to these functions being carried out, must be clear of all waste material/objects, as the machine will be moving for the first time from switch on.

Once these tests have been carried out, the screen will display the main menu.

Menù main



You can access all of the program environments from the Main Menu and specifically:

- automatic work environment
- manual controls environment
- axis calibration environment
- *machine service/setup* environment
- I/O test environment
- alarm log environment

Manual cutting function

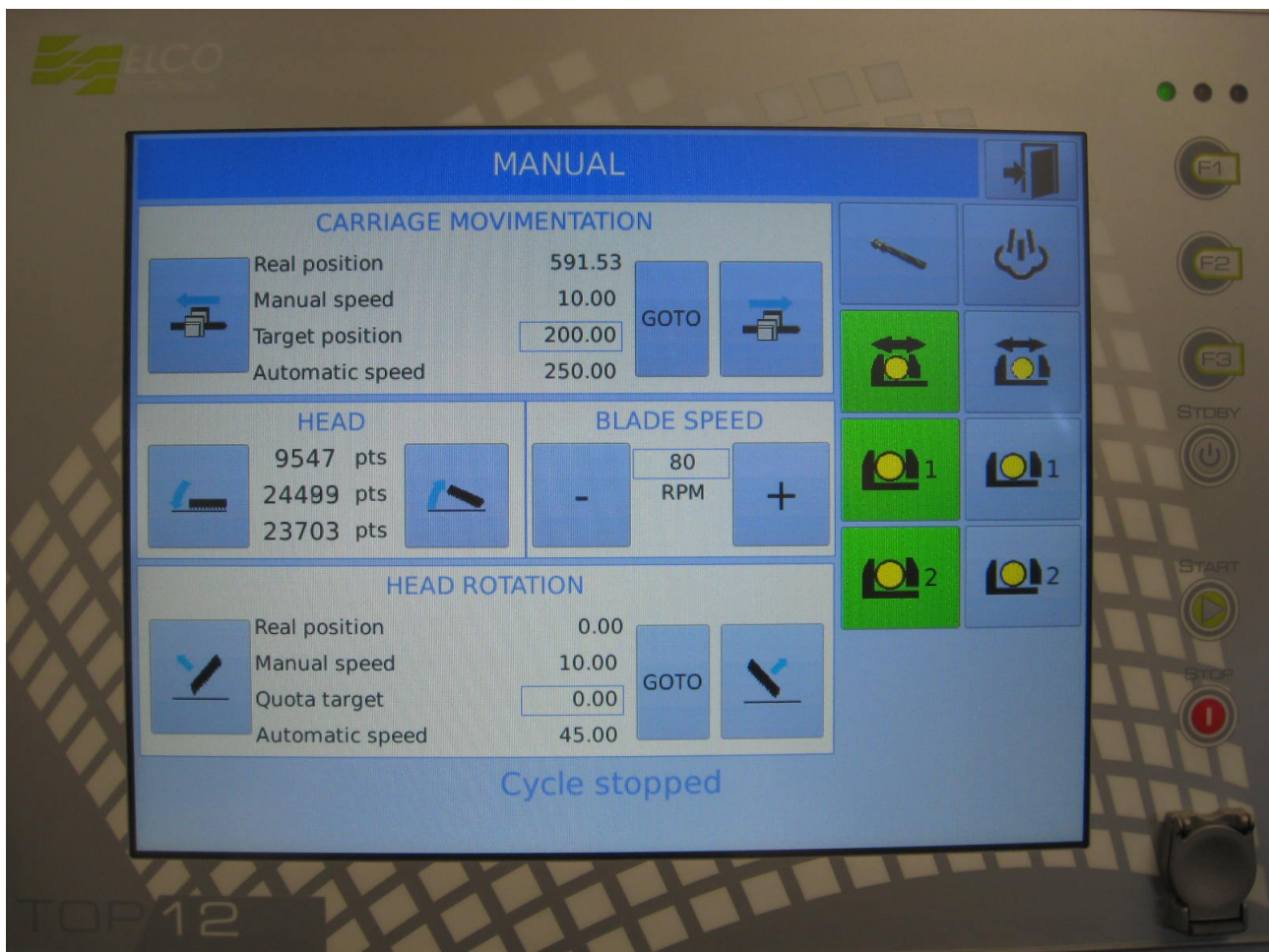

To view this screen ,press manual from the main menu.

CARRIAGE: to move carriage manually, press arrow left for left and arrow right for right.

To move the carriage automatically, enter the value you wish to move the carriage too by pressing the highlighted box , target position enter the value and enter then press GOTO, The carriage will move to the value entered.

HEAD ROTATION: to rotate the head/blade left or right, similar to the above left or right buttons manually, or enter value into QUOTA TARGET box, shown above.

Note: this machine can carry out the feature of -45 degrees left and 45 degrees right, with all angles in between.

HEAD: this function allows you to raise and lower the head/blade manually, using the up and down arrows.

BLADE SPEED: either enter value required in highlighted box or using – or + buttons increase the rpm up or down.

CLAMPS: from the photo you can find 3 clamps ,at present showing in a green colour, this shows the clamps closed, by pressing the buttons to the right of the buttons, this will allow you to open the clamps, clamp 1 is the left fixed vice, clamp 2 is the right fixed vice, the top shown clamp with a double arrow is the carriage vice.

Machine Setup

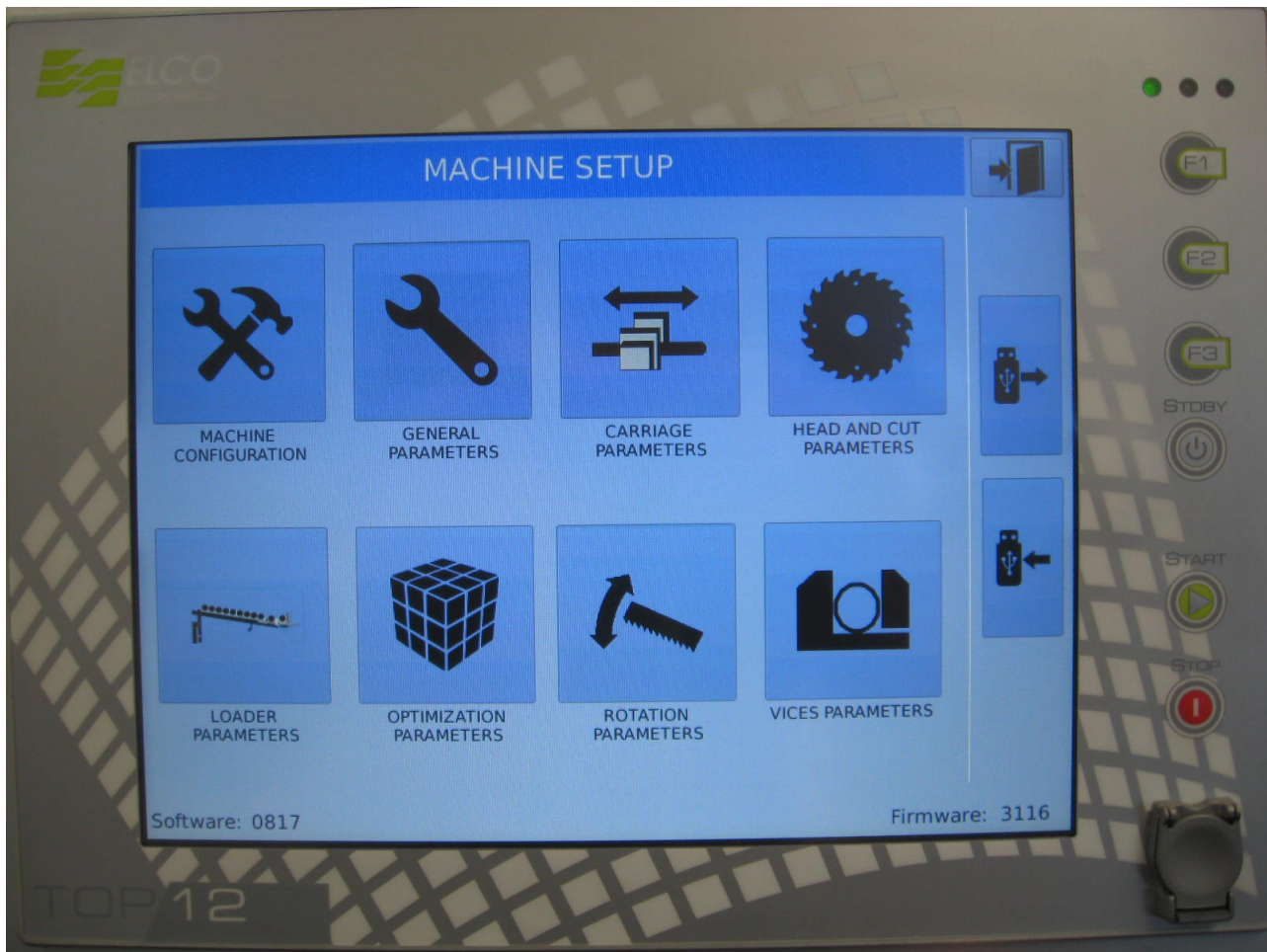

From the main menu, press machine set-up the screen above will appear.

This screen is developed to access all the parameters for the TOP10 panel,

At the base of the screen it will show the software and firmware editions .

To access the parameters, passwords will be required, due to the importance of these parameters to remain factory set, please contact your MACC representative, who will be happy to assist you with your requirements.

Automatic cutting screen (part 1)

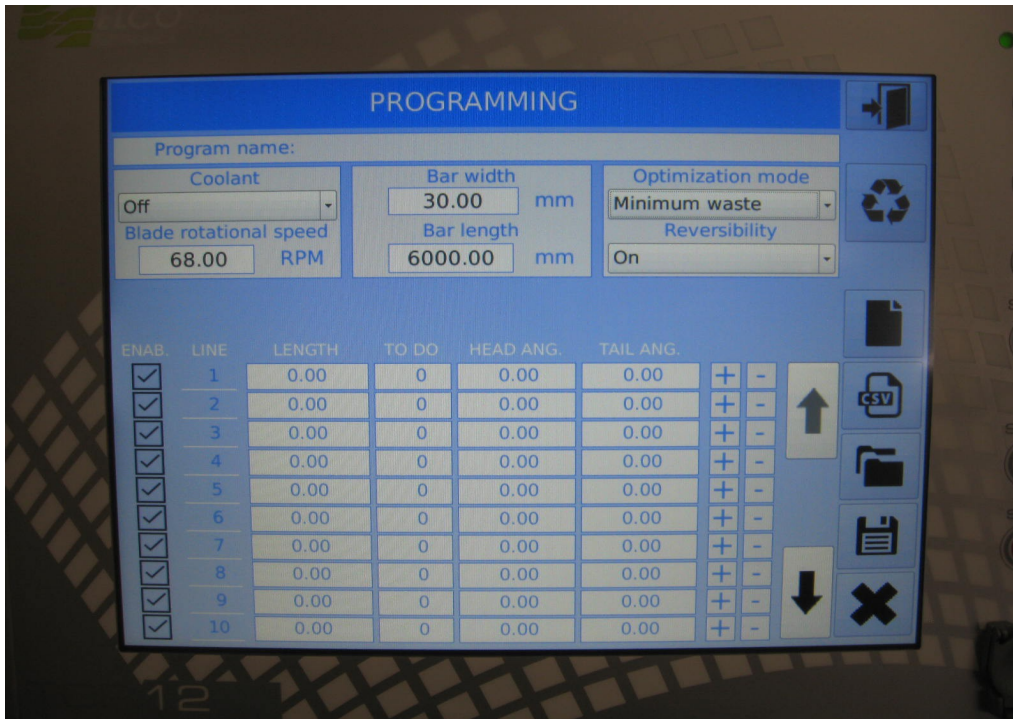

To view this screen above, from the main menu press AUTOMATIC, the screen above will appear.

- PROGRAM NAME enter job number/name.
- COOLANT on/off
- BLADE ROTATION SPEED enter blade speed required.
- BAR WIDTH enter bar/tube width
- BAR LENGTH enter bar/tube length(starting length ie,6000mm=6m)
- REVERSIBILITY on/off
- TRIM CUT on/off

When programming your cutting list for automatic mode, you must carry out the correct input procedures.

For ex. LINE 1 : lenght : 100mm – quantity : 4

HEAD ANGLE : – 45 and TAIL ANGLE : 45.

NOTE : Remember that the HEAD ANGLE must be a lower value than the TAIL ANGLE.
(if you insert : TAIL ANGLE -45, the machine will not function).

Once all sizes and values have been programmed, press START AUTO CYCLE button (see page 10).

Another screen will show. Now press the 0 button followed by the magnifying button at the bottom right of the page.

Now lower the head just above the material and you are ready to cut.

NOTE : reset the descent regulator before pressing START.

Automatic cutting screen (part 2)

Return to previous or main menu.



Start Auto Cycle.



New Program.

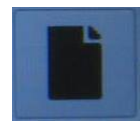

CSV file extract.



Folders.



Save.



Cancel.



General parameters

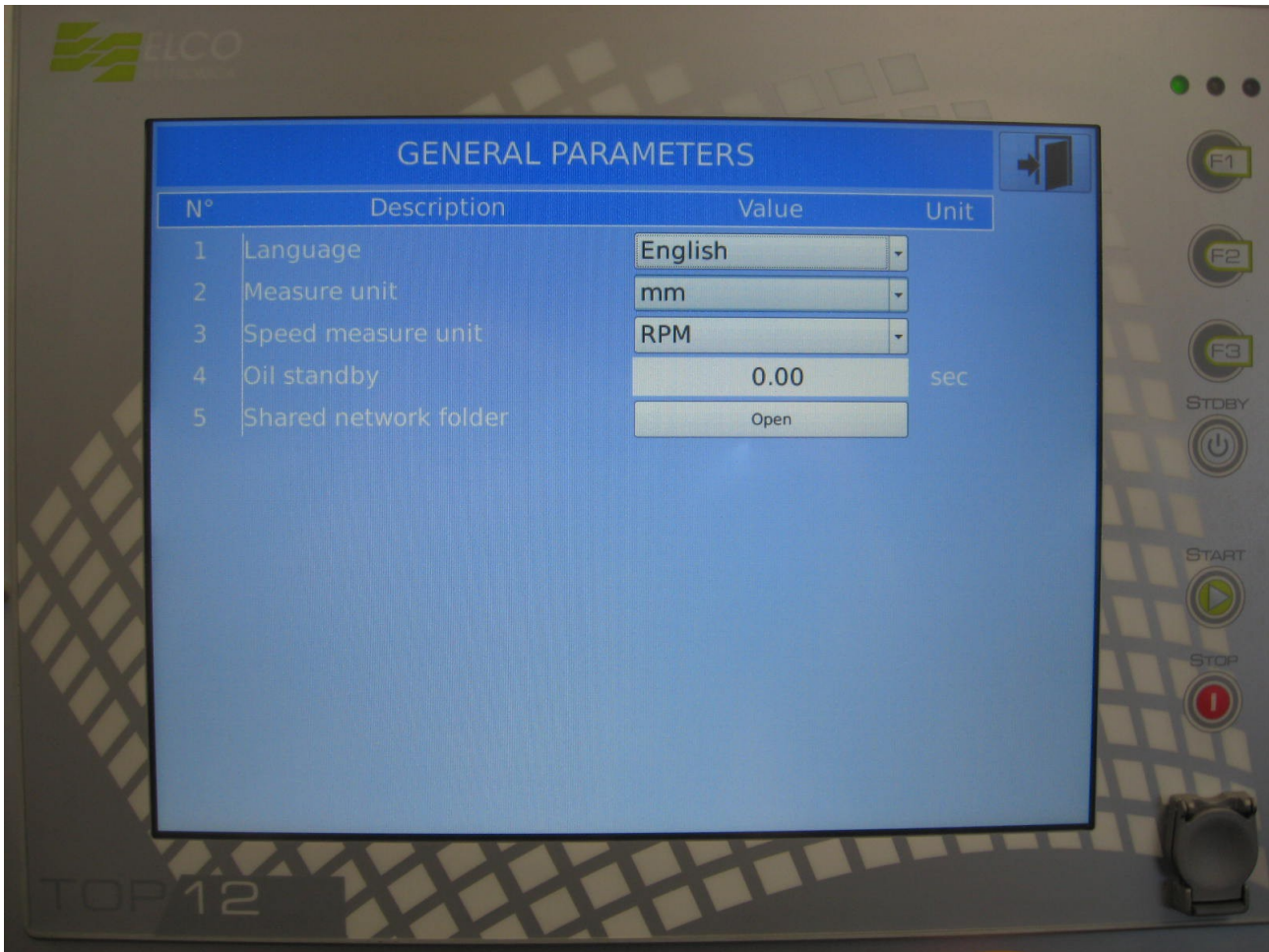

Number 1, Language.

English / Polish / Italian.

Number 2, Measure unit.

mm / cm / inch

Number 3, Speed measure unit .

rpm

Number 4, Oil Stand-by .

n/a

Number 5, Shared network folder.

Open

PASSWORD FOR ENTRY TO GENERAL PARAMETERS = 1 2 3 4

Alarm log

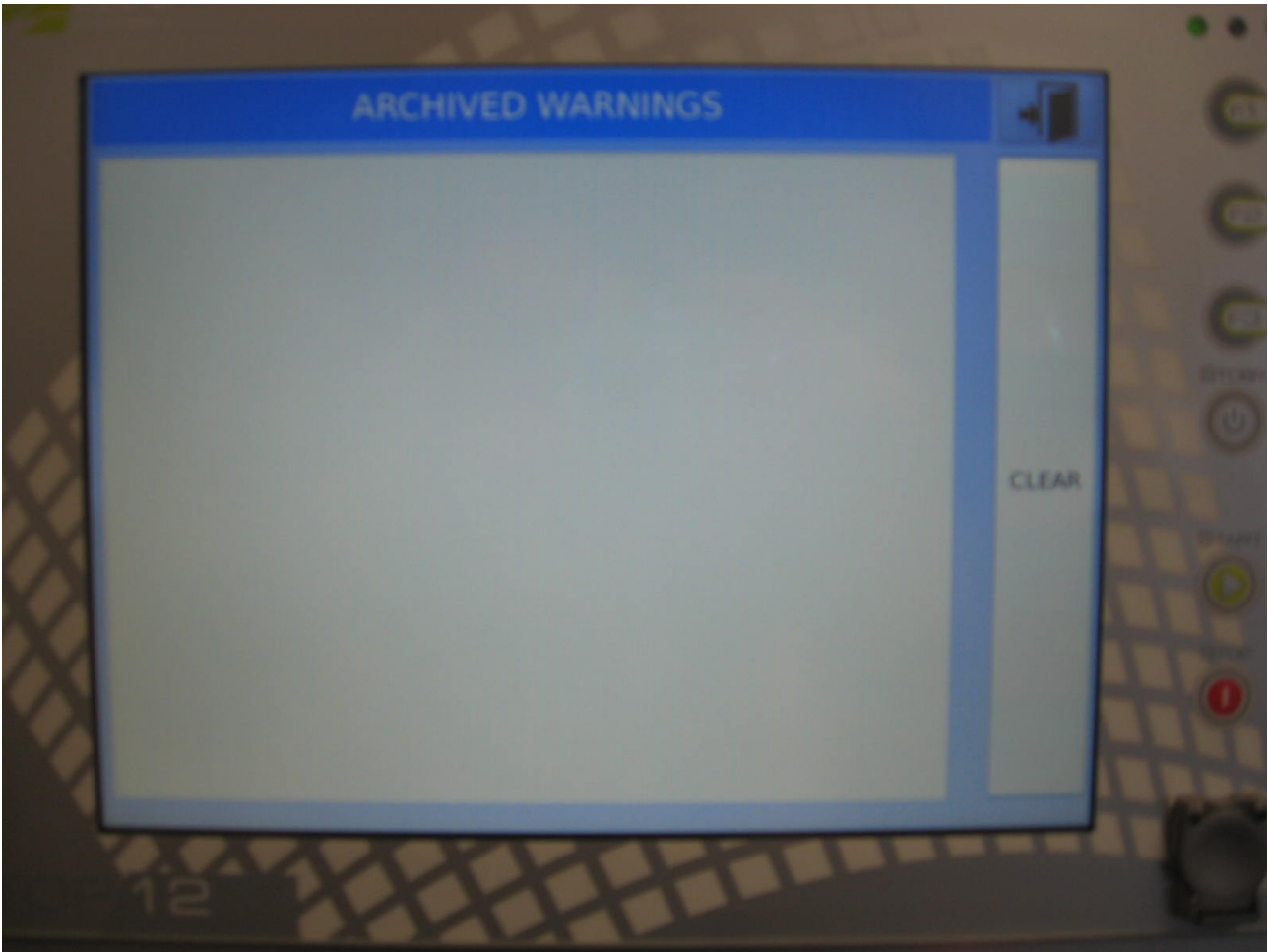

From the main menu press ARCHIVED WARNINGS, the screen above will appear, this screen will show all the emergencies pressed or occurred for the life of the panel, to clear all alarms,press the clear button to the right hand side of the screen, this will clear all historic alarms from the plc.

To set high and low points of the blade



From the main menu screen, press AXIS HOMING button, once you see photo from page 5, press the START and STOP buttons together, the screen above will now appear.

This section is to prevent when changing the blade or changing the fulcrum from middle, cutting into the bed of the machine, ie if the blade on the machine diameter is 320mm and is changed to 370mm the low point will need to be raised to prevent the larger blade going to a lower point.

To carry out this operation, lower the head/blade with the down arrow button, using the decent regulator to control the feed, once you have archived the low point press the LOW POINT button in the memorization section, you will see the value change.

Now raise the head/blade using the up arrow to the desired height and press the HIGH POINT button, this will also change the value in the memorization section.

Remember to set your decent regulator back to 0, as the decent may be too fast for the cutting procedure.

Fulcrum settings

To access the parameters, passwords will be required, due to the importance of these parameters to remain factory set, please contact your MACC representative, who will be happy to assist you with your requirements.

The below screen can be found from the main menu, press MACHINE SETUP, now press HEAD ROTATION enter the password, the screen below will now appear.

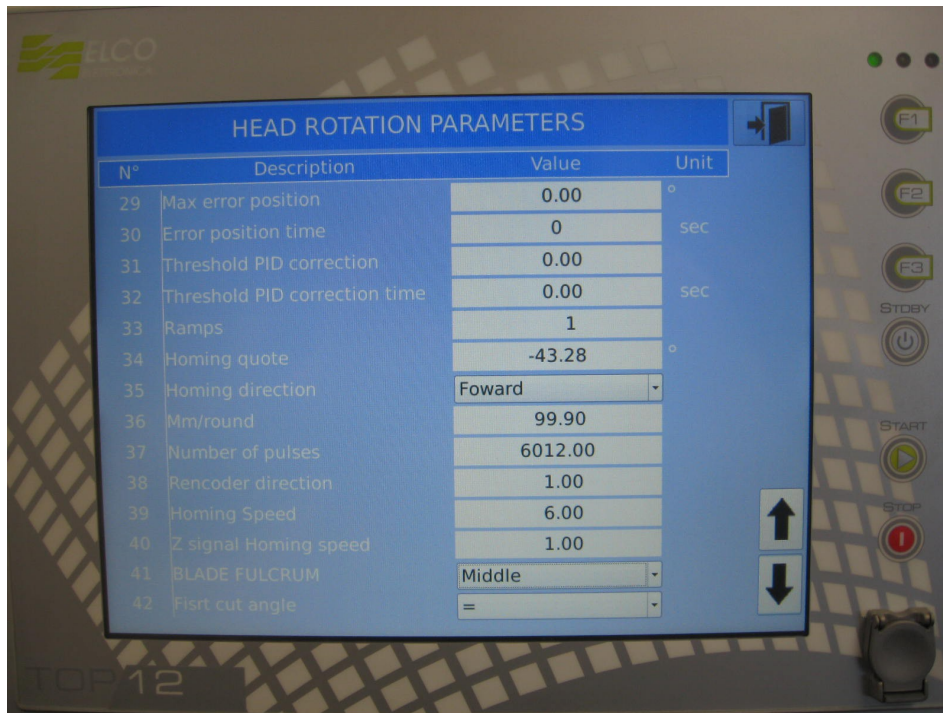

Number 41 will enable the machine to be changed from MIDDLE to EXTERN, if the machine is set to MIDDLE the back vice will need to be changed using handwheel at rear of machine, if the machine is set to EXTERN the handwheel will be required to be set at 0 and remain for all sizes off material , remember that the capacity is reduced using the Extern feature.

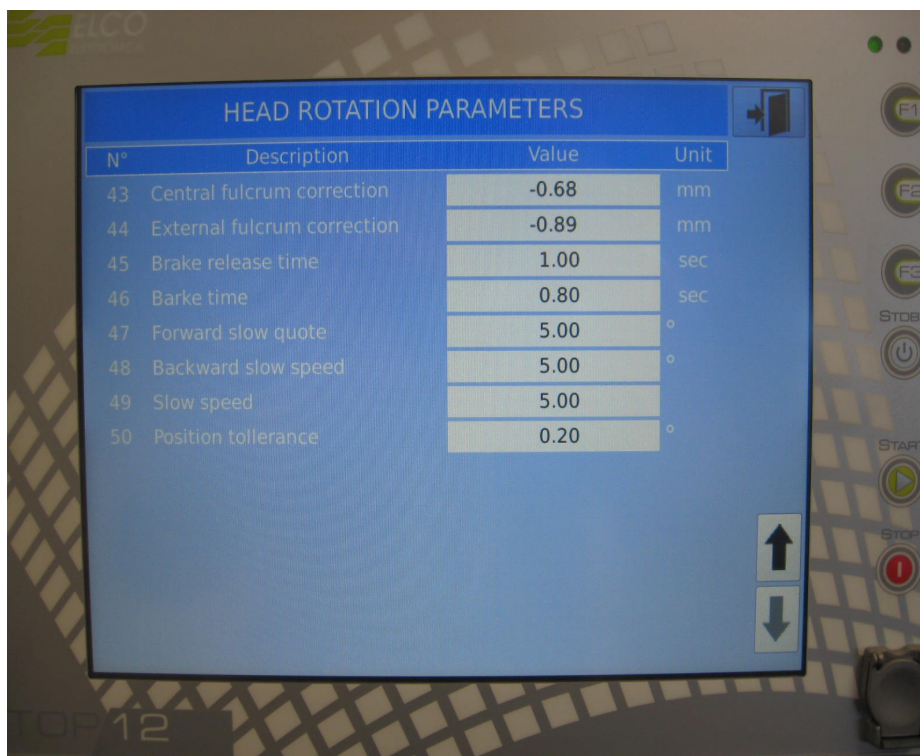

The settings for all parameters are set at factory, Macc advise that these should remain the same at all times apart from the fulcrum number 41 above.

To change the fulcrum setting, when set to MIDDLE



Note: When operating the machine with the fulcrum set to MIDDLE, the width of material must be entered into the bar width highlighted box, as the piece being cut.

Now you will be required to change the dimension of the width of material at the rear of the machine using the handwheel, the number required must be the same value as the number in the bar width box and the material being cut.

At the end of the changes being carried out, make sure that all clamps/vice jaws are clear from the blade and the low point is set, to allow the clear cutting of the material.

On trim cut ie: the first cut in automatic cycle, the 3rd clamp (far right) will not clamp on the 1st cut, make sure that when the clamp is open and the machine is set to 45 degrees + the blade does not hit the clamp/vice jaw on the way down in decent.

Download of software, languages and updates

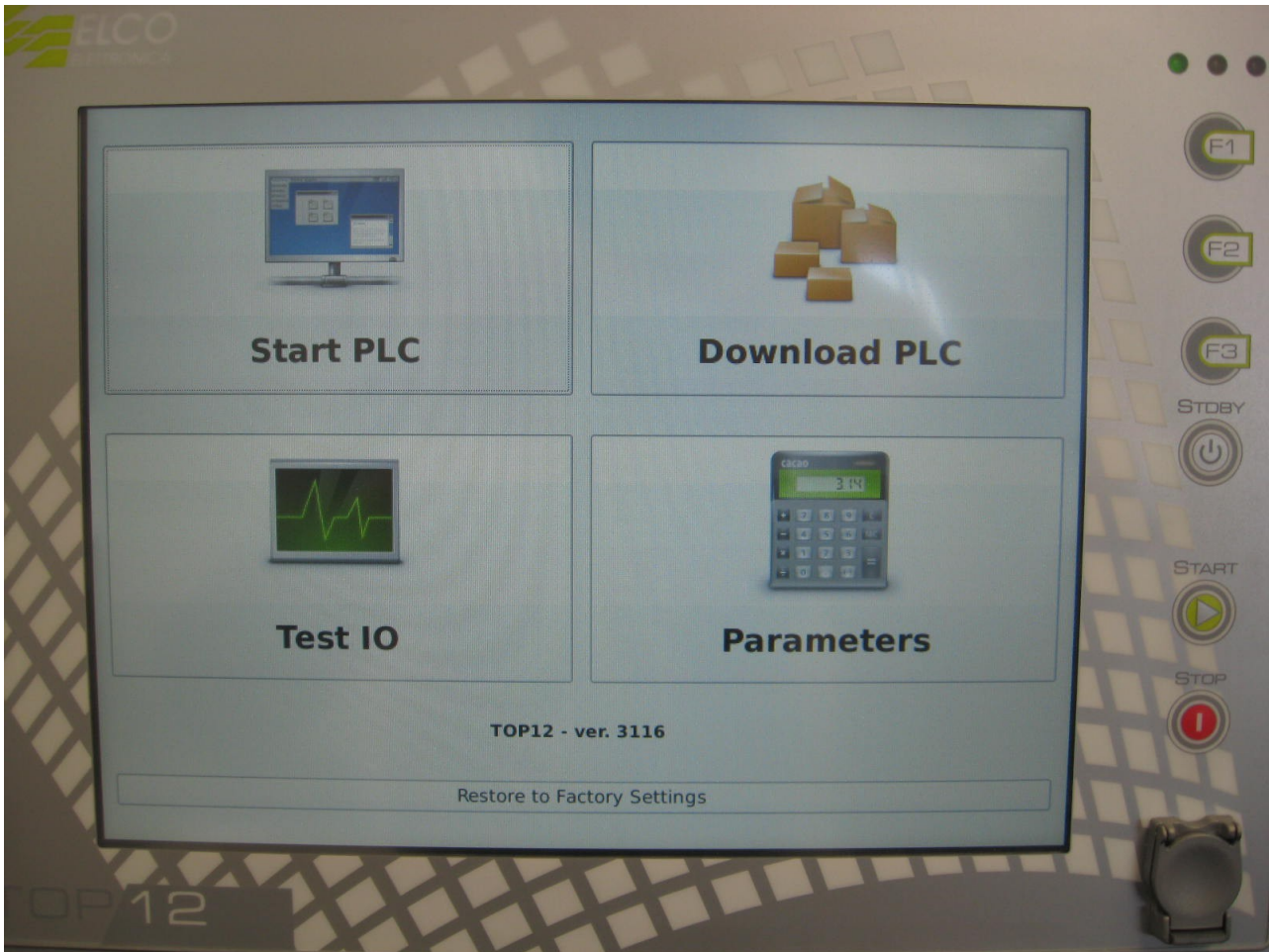

From the main menu press F1 and F2 together, the screen above will show.

Once you have placed the USB key into the slot at the bottom right corner of the TOP 10 panel, proceed by pressing the download plc button, this will allow you to update/upload new software setting and modifications if required.

On completion of any updates, press the start plc button, this will upload and test the panel and revert to the main menu.

Test and connection using Ethernet setting

From the main menu, press the test button after a short time the screen below will show. Please, disconnect to wifi prior to connecting TOP10 to your PC.

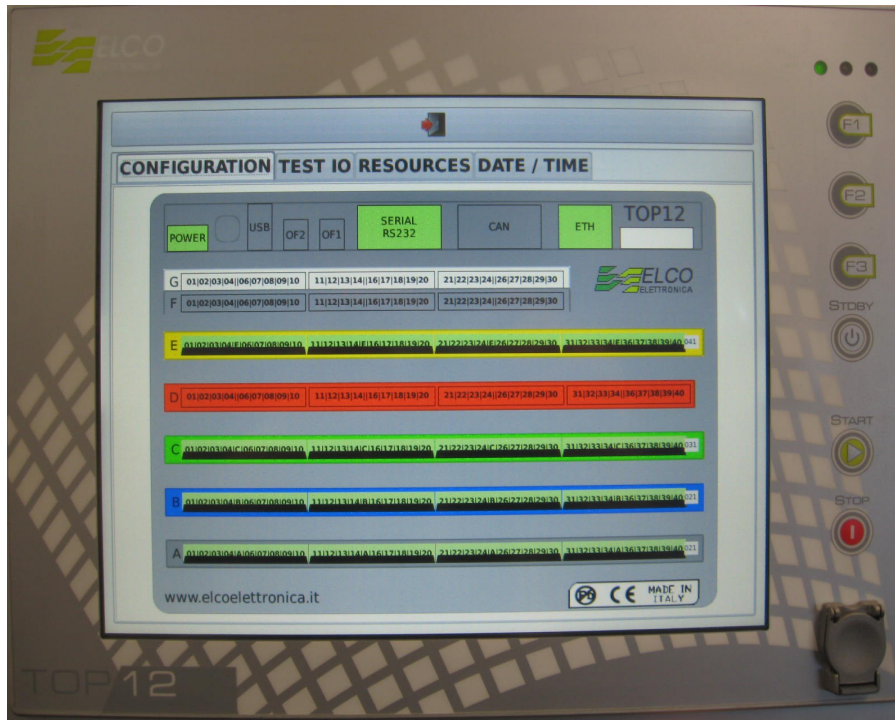

To connect your pc/network, using vnc viewer press resources and the screen below will show.

The first 3 lines of this screen must be the same as your pc ip address, this will allow you to see on your pc what is on the panel of the machine, also allowing for further connections to be made for extra support elsewhere.

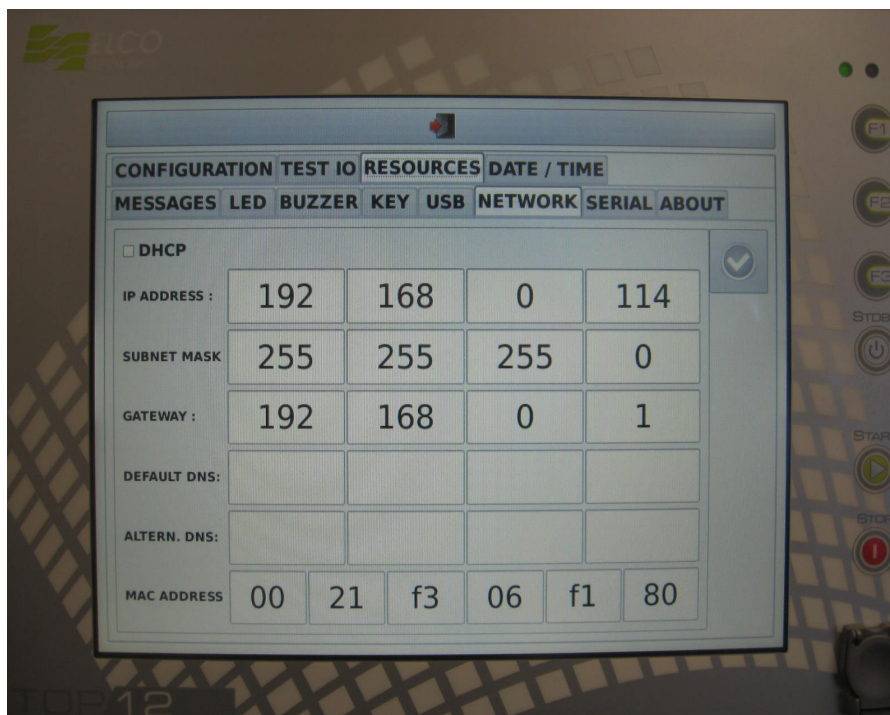

Emergencies

The PLC system will report the following emergencies:

ID	EMERGENCY	CAUSE	MANAGEMENT CONDITION
1	Emergency stop button (NC)	IN 1 = 0	Always. No machine movement is allowed.
2	Blade motor thermal cut-out switch (NC)	IN 2 = 0	Always. No machine movement is allowed.
3	FC blade breakage (NC)	IN 3 = 0	Cutting cycles are not allowed but manual movements of the axes, clamps and the arc are possible.
4	FC guard open (NC)	IN 4 = 0	Cutting cycles are not allowed but manual movements of the axes, clamps and the arc are possible.
5	Carriage drive fault (NC)	IN 5 = 0	Always. No machine movement is allowed.
6	Oil thermal cut-out switch (NC)	IN 6 = 0	Always. No machine movement is allowed.
7	Emergency stop handle (N.C.)	IN 7 = 0	Cutting cycles are not allowed but manual movements of the axes, clamps and the arc are possible.
8	Coolant thermal cut-out switch (N.C.)	IN 8 = 0	Always. No machine movement is allowed.
9	Shavings cleaner thermal cut-out switch (NC)	IN 9 = 0	Always. No machine movement is allowed.
10	Head drive fault (NC)	IN 15 = 0 & angle cutting enabled	Always. No machine movement is allowed. To evaluate only if angle cutting is enabled.
11	Part guide motor thermal cut-out switch (NC)	IN 23 = 0 & loader enabled	Always. No machine movement is allowed. To evaluate only if the Loader is enabled.

I/O List

DIGITAL INPUTS 24V – EC7 DIO_021 – SLOT A		
POLE number	DESCRIPTION	I/O TEST
1	Emergency stop button (NC)	1
2	Blade motor thermal cut-out switch (NC)	2
3	FC blade breakage (NC)	3
4	FC guard open (NC)	4
5	Carriage drive fault (NC)	5
6	Oil thermal cut-out switch (NC)	6
7	Emergency stop handle (N.C.)	7
8	Coolant thermal cut-out switch (N.C.)	8
9	NC	
10	0 Volt - Common inputs	

DIGITAL INPUTS 24V – EC7 DIO_021 – SLOT A		
POLE number	DESCRIPTION	I/O TEST
11	Shavings cleaner thermal cut-out switch (NC)	9
12	FC Lack of Material	10
13	FC Carriage forward + Calibration	11
14	FC blade down	12
15	Feeler	13
16	FC Head Rotation + Calibration	14
17	Head drive fault (NC)	15
18	Blade change selector	16
19	NC	
20	0 Volt - Common inputs	

DIGITAL INPUTS 24V – EC7 DIO_021 – SLOT B

POLE number	DESCRIPTION	I/O TEST
1	End-machining laser	17
2	Fixed clamp pressure switch	18
3	FC cylinder lift up (Loader)	19
4	Part detection (Loader)	20
5	FC part guide forward (Loader)	21
6	FC part guide back (Loader)	22
7	Part guide motor thermal cut-out switch (NC) (Loader)	23
8	Loaded bar pressure switch	24
9	NC	
10	0 Volt - Common inputs	

DIGITAL INPUTS 24V – EC7 DIO_021 – SLOT B

POLE number	DESCRIPTION	I/O TEST
11	<i>Spare</i>	25
12	<i>Spare</i>	26
13	<i>Spare</i>	27
14	<i>Spare</i>	28
15	<i>Spare</i>	29
16	<i>Spare</i>	30
17	<i>Spare</i>	31
18	<i>Spare</i>	32
19	NC	
20	0 Volt - Common inputs	

DIGITAL OUTPUTS 24V – EC7 DIO_021 – SLOT A

POLE number	DESCRIPTION	I/O TEST
21	Enable carriage / Carriage forward	1
22	Carriage back	2
23	Arc down	3
24	Arc down fast	4
25	Arc up	5
26	Blade rotation on	6
27	Oil pump on	7
28	Coolant on	8
29	+24V power supply outputs	
30	0 V	

DIGITAL OUTPUTS 24V – EC7 DIO_021 – SLOT A

POLE number	DESCRIPTION	I/O TEST
31	Shavings suction on	9
32	Nebulizer on	10
33	Mobile clamp opening	11
34	Mobile clamp closing	12
35	Fixed clamp opening	13
36	Fixed clamp closing	14
37	Drive alarm reset	15
38	<i>Spare</i>	16
39	+24V power supply outputs	
40	0 V	

DIGITAL OUTPUTS 24V – EC7 DIO_021 – SLOT B

POLE number	DESCRIPTION	I/O TEST
21	Arc rotation release	17
22	Enable arc rotation / Arc rotation forward	18
23	Arc rotation back	19
24	Lift up (Loader)	20
25	Part guide forward command (Loader)	21
26	Part guide back command (Loader)	22
27	Closing of bar holding clamp (Loader)	23
28	Fixed clamp 2 closing	24
29	+24V power supply outputs	
30	0 V	

DIGITAL OUTPUTS 24V – EC7 DIO_021 – SLOT B

POLE number	DESCRIPTION	I/O TEST
31	Fixed clamp 2 opening	25
32	<i>Spare</i>	26
33	<i>Spare</i>	27
34	<i>Spare</i>	28
35	<i>Spare</i>	29
36	<i>Spare</i>	30
37	<i>Spare</i>	31
38	<i>Spare</i>	32
39	+24V power supply outputs	
40	0 V	

AXES – EC7AS_031 - SLOT C

POLE number	DESCRIPTION
1	Channel A - Encoder X (Carriage advancer)
2	Channel /A - Encoder X (Carriage advancer)
3	Channel B - Encoder X (Carriage advancer)
4	Channel /B - Encoder X (Carriage advancer)
5	Channel Z - Encoder X (Carriage advancer)
6	Channel /Z - Encoder X (Carriage advancer)
7	+5V (power supply encoder)
8	<i>reserved</i>
9	+24V DC (power supply encoder)
10	+0 V

AXES – EC7AS_031 - SLOT C

POLE number	DESCRIPTION
11	Channel A - Encoder Y (Angle cutting)
12	Channel /A - Encoder Y (Angle cutting)
13	Channel B - Encoder Y (Angle cutting)
14	Channel /B - Encoder Y (Angle cutting)
15	Channel Z - Encoder Y (Angle cutting)
16	Channel /Z - Encoder Y (Angle cutting)
17	+5V (power supply encoder)
18	<i>reserved</i>
19	+24V DC (power supply encoder)
20	+0 V

AXES – EC7AS_031 - SLOT C

POLE number	DESCRIPTION
21	Carriage drive speed control +/-10V
22	Cutting angle speed control +/- 10V
23	<i>available</i>
24	<i>available</i>
25	<i>available</i>
26	<i>available</i>
27	<i>available</i>
28	<i>available</i>
29	<i>available</i>
30	+0 V

AXES – EC7AS_031 - SLOT C

POLE number	DESCRIPTION
31	<i>available</i>
32	<i>available</i>
33	<i>available</i>
34	<i>available</i>
35	<i>available</i>
36	<i>available</i>
37	<i>available</i>
38	<i>available</i>
39	<i>available</i>
40	+0 V

AXES – EC7AS_031 - SLOT D

POLE number	DESCRIPTION
1	Channel A - Encoder Z (Loader position)
2	Channel /A - Encoder Z (Loader position)
3	Channel B - Encoder Z (Loader position)
4	Channel /B - Encoder Z (Loader position)
5	Channel Z - Encoder Z (<i>Spare</i>)
6	Channel /Z - Encoder Z (<i>Spare</i>)
7	+5V (power supply encoder)
8	<i>reserved</i>
9	+24V DC (power supply encoder)
10	+0 V

AXES – EC7AS_031 - SLOT D

POLE number	DESCRIPTION
11	<i>Channel A - Encoder W (Spare)</i>
12	<i>Channel /A - Encoder W (Spare)</i>
13	<i>Channel B - Encoder W (Spare)</i>
14	<i>Channel /B - Encoder W (Spare)</i>
15	<i>Channel Z - Encoder W (Spare)</i>
16	<i>Channel Z/ - Encoder W (Spare)</i>
17	+5V (power supply encoder)
18	<i>reserved</i>
19	+24V DC (power supply encoder)
20	+0 V

AXES – EC7AS_031 - SLOT D

POLE number	DESCRIPTION
21	Analogue output Z - <i>Spare</i>
22	Analogue output W - <i>Spare</i>
23	<i>available</i>
24	<i>available</i>
25	<i>available</i>
26	<i>available</i>
27	<i>available</i>
28	<i>available</i>
29	<i>available</i>
30	+0 V

AXES – EC7AS_031 - SLOT D

POLE number	DESCRIPTION
31	<i>available</i>
32	<i>available</i>
33	<i>available</i>
34	<i>available</i>
35	<i>available</i>
36	<i>available</i>
37	<i>available</i>
38	<i>available</i>
39	<i>available</i>
40	+0 V

ANALOGUE I/O BOARD - EC7AI_041 - SLOT E

POLE number	DESCRIPTION
1	ANALOGUE INPUT 1 - Arc height potentiometer
2	<i>Not used</i>
3	<i>Not used</i>
4	<i>Not used</i>
5	ANALOGUE INPUT 2 – Blade deviation sensor
6	<i>Not used</i>
7	<i>Not used</i>
8	<i>Not used</i>
9	+5V (Potentiometer power supply)
10	+0 V

ANALOGUE I/O BOARD - EC7AI_041 - SLOT E

POLE number	DESCRIPTION
11	<i>ANALOGUE INPUT 3 - VOLTAGE 0-10V - (Spare)</i>
12	<i>ANALOGUE INPUT 3 - VOLTAGE 4-20 mA - (Spare)</i>
13	<i>ANALOGUE INPUT 3 - VOLTAGE PT100 - (Spare)</i>
14	<i>ANALOGUE INPUT 3 - VOLTAGE PT100 - (Spare)</i>
15	<i>ANALOGUE INPUT 4 - VOLTAGE 0-10V - (Spare)</i>
16	<i>ANALOGUE INPUT 4 - VOLTAGE 4-20 mA - (Spare)</i>
17	<i>ANALOGUE INPUT 4 - VOLTAGE PT100 - (Spare)</i>
18	<i>ANALOGUE INPUT 4 - VOLTAGE PT100 - (Spare)</i>
19	+5V (Potentiometer power supply)
20	+0 V

ANALOGUE I/O BOARD - EC7AI_041 - SLOT E

POLE number	DESCRIPTION
21	<i>ANALOGUE INPUT 5 - VOLTAGE 0-10V - (Spare)</i>
22	<i>ANALOGUE INPUT 5 - VOLTAGE 4-20 mA - (Spare)</i>
23	<i>ANALOGUE INPUT 5 - VOLTAGE PT100 - (Spare)</i>
24	<i>ANALOGUE INPUT 5 - VOLTAGE PT100 - (Spare)</i>
25	<i>ANALOGUE INPUT 6 - VOLTAGE 0-10V - (Spare)</i>
26	<i>ANALOGUE INPUT 6 - VOLTAGE 4-20 mA - (Spare)</i>
27	<i>ANALOGUE INPUT 6 - VOLTAGE PT100 - (Spare)</i>
28	<i>ANALOGUE INPUT 6 - VOLTAGE PT100 - (Spare)</i>
29	Analogue output A - Blade speed regulation
30	+0 V

ANALOGUE I/O BOARD - EC7AI_041 - SLOT E



POLE number	DESCRIPTION
31	<i>ANALOGUE INPUT 7 - VOLTAGE 0-10V - (Spare)</i>
32	<i>ANALOGUE INPUT 7 - VOLTAGE 4-20 mA - (Spare)</i>
33	<i>ANALOGUE INPUT 7 - VOLTAGE PT100 - (Spare)</i>
34	<i>ANALOGUE INPUT 7 - VOLTAGE PT100 - (Spare)</i>
35	<i>ANALOGUE INPUT 8 - VOLTAGE 0-10V - (Spare)</i>
36	<i>ANALOGUE INPUT 8 - VOLTAGE 4-20 mA - (Spare)</i>
37	<i>ANALOGUE INPUT 8 - VOLTAGE PT100 - (Spare)</i>
38	<i>ANALOGUE INPUT 8 - VOLTAGE PT100 - (Spare)</i>
39	Analogue output B - Proportional arc down EV
40	+0 V

I/O description and operation

OUTPUT	NAME	DESCRIPTION
1		
2		
3		
4		
5		
6		
7		
8		
9		
10		
11		
12		
13		
14		
15		
16		

INPUT	NAME	DESCRIPTION
1		
2		
3		
4		
5		
6		
7		
8		
9		
10		
11		
12		
13		
14		
15		
16		

CAPACITA' DI TAGLIO - Special 411 AG

CAPACITA' DI TAGLIO CUTTING CAPACITY - CAPACITE DE COUPE SCHNITTKAPAZITAET - CAPACIDAD DE CORTE			
90°	290	280	280 x 300
45° Sinistra - left - links - gauche	180	160	110 x 180
45° Destra - right - droite - rechts	240	220	120 x 240

SCELTA DELLA LAMA

SCELTA DELLA LAMA
 SELECTION OF BLADE
 CHOIX DE LA LAME
 WAHL DES SAEGERBLATTS
 SELECCION DE LA HOJA

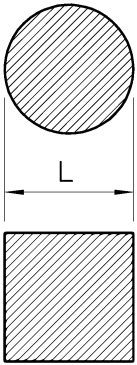
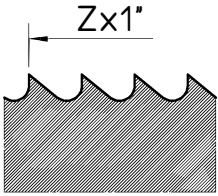
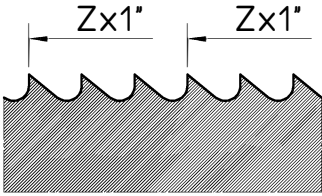
 L mm			
	≤ 40	8	6/10
	$>30 < 80$	6	5/8
	$>60 < 90$	4	4/6
	≤ 100	3	3/4

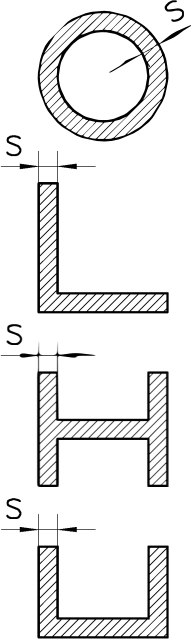
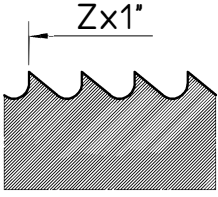
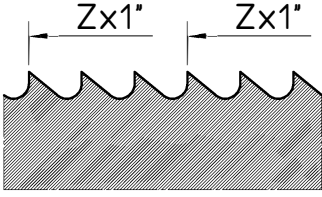
 S mm			
	$\leq 1,5$	14	-
	$>1 < 2$	10	10/14
	$>2 < 4$	8	8/12
	$>4 < 8$	6	6/10
	$>6 < 12$	6	5/8
	≤ 12	4	4/6

Velocità di taglio La macchina è dotata di due velocità di taglio		38-77 m/1'
Cutting machine The machine is equipped with two cutting speeds		38-77 m/1'
Vitesse de coupe La machine est dotée de deux vitesses de coupe		38-77 m/1'
Schnittgeschwindigkeit Die maschine ist mit zwei Schnittgeschwindigkeiten ausgestattet		38-77 m/1'
Velocidad de corte La maquina esta dotada de dos velocidades de corte		38-77 m/1'
Materiale Material Materiel Material Material		Velocità di taglio m/1' Cutting machine m/1' Vitesse de coupe m/1' Schnittgeschwindigkeit m/1' Velocidad de corte m/1'
Acciai da costruzione Structural steel Aciers de construction Baustahl Acero de construccion	Fe37+Fe42 Fe37+Fe42 Fe37+Fe42 Fe37+Fe42 Fe37+Fe42	Pieni Solid Pleins Volles Material Pies 77 Profilati Structural steel Profilés Profile Perfiles 77
Acciai da costruzione Structural steel Aciers de construction Baustahl Acero de construccion	Fe50+Fe70 Fe50+Fe70 Fe50+Fe70 Fe50+Fe70 Fe50+Fe70	77
Acciai al carbonio Carbon steel Aciers au carbone Kohlenstoffstahl Acero de carbono	C40+C60 C40+C60 C40+C60 C40+C60 C40+C60	77
Acciai legati Alloyed steel Aciers allié Legierter Stahl Acero aleado		38
Acciai inox Stainless steel Aciers inoxydables Rostfreier Stahl Acero inoxidable		38
Ghisa grigia Grey cast iron Fonte grise Grauguß Fundición gris		77
Leghe d'alluminio Aluminium alloys Allieges d'aluminium Legierungen aus Aluminium Aleación de Aluminio		77
Bronzi Bronze Bronze Bronze Bronces		77

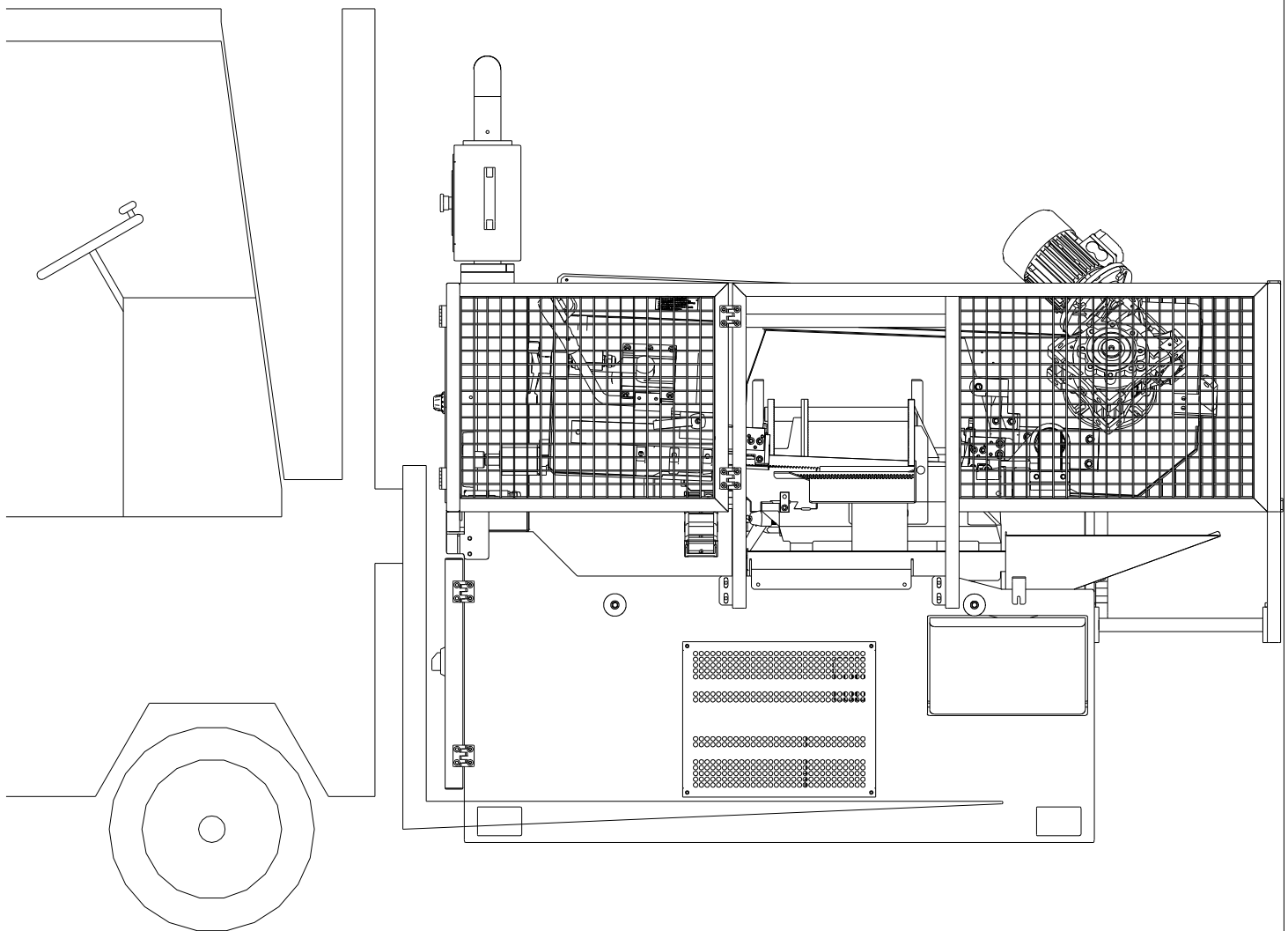

* = ALTEZZA PIANO DI LAVORO
Working table height

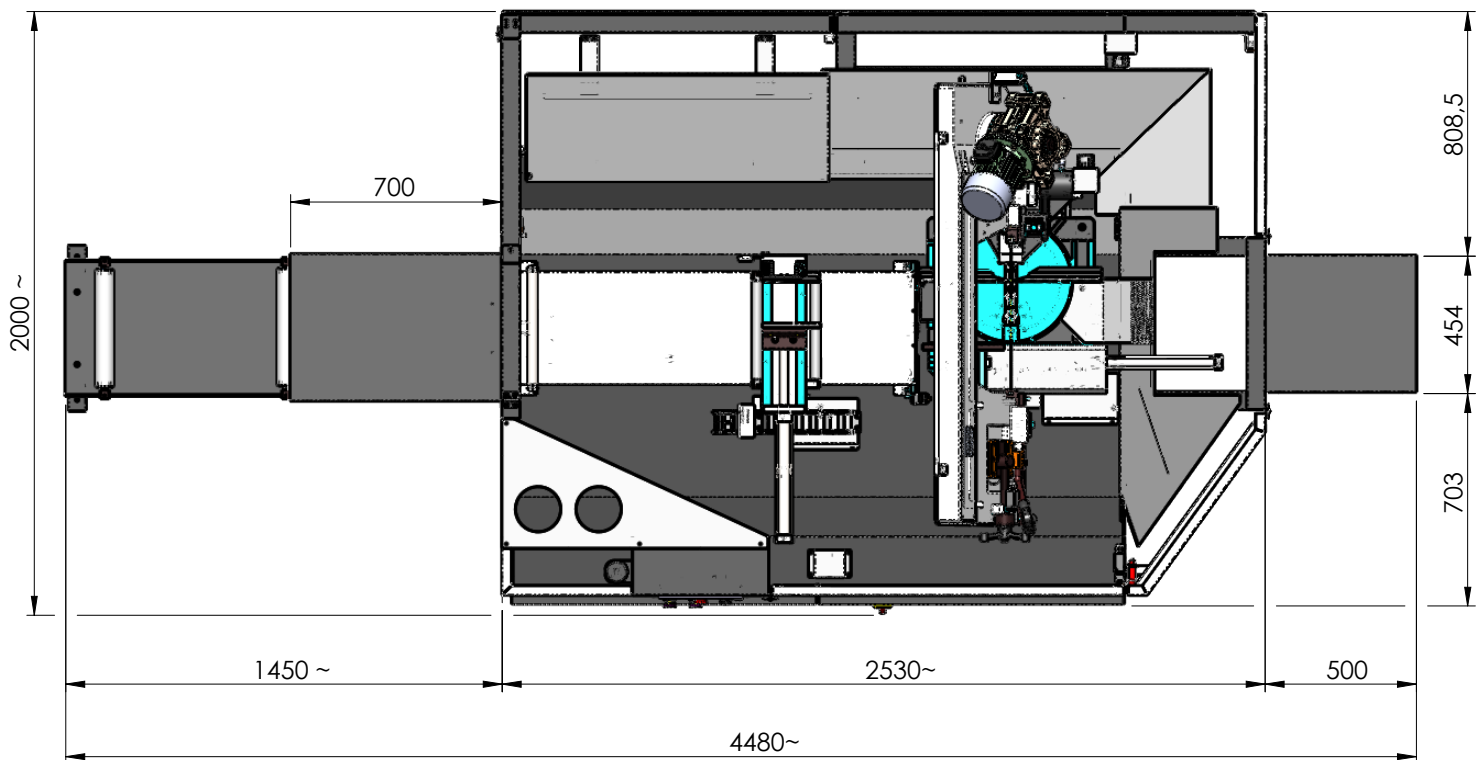
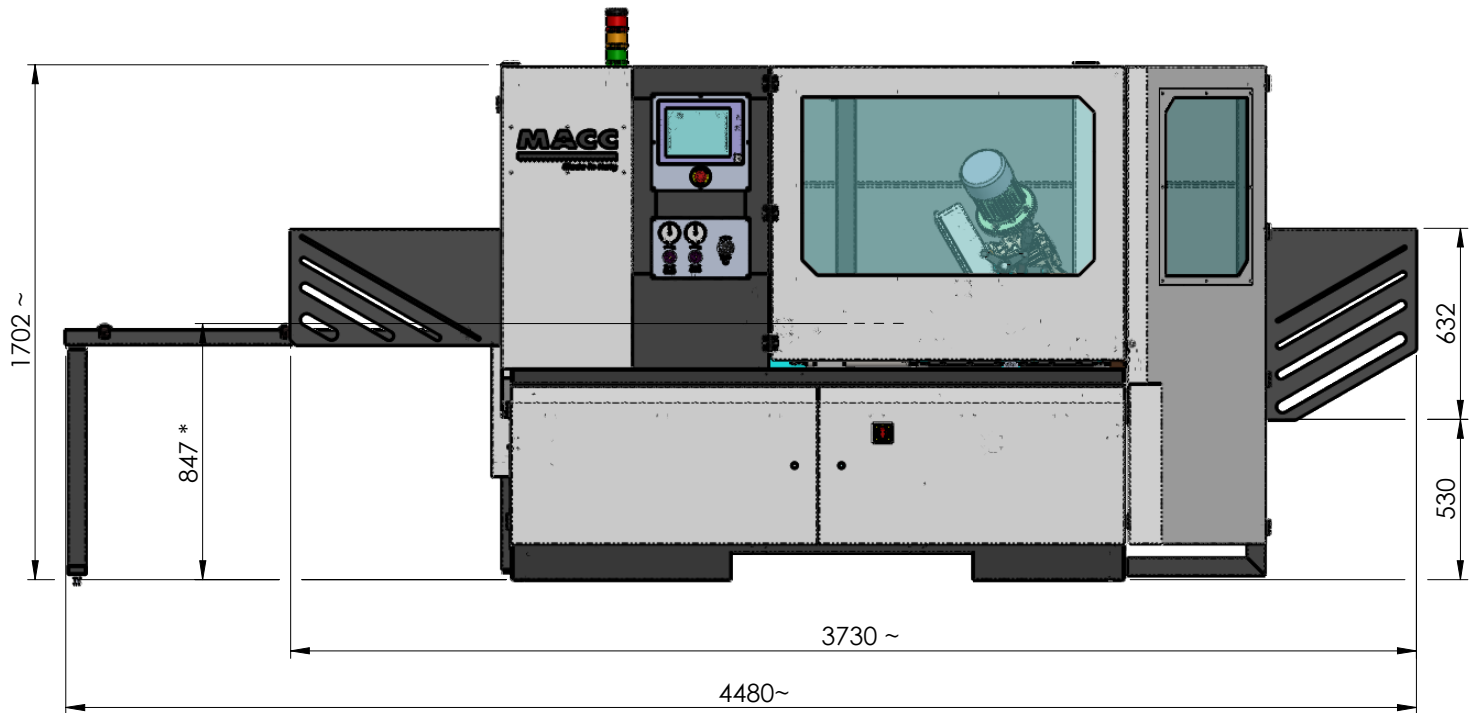

SPECIAL-411-AG

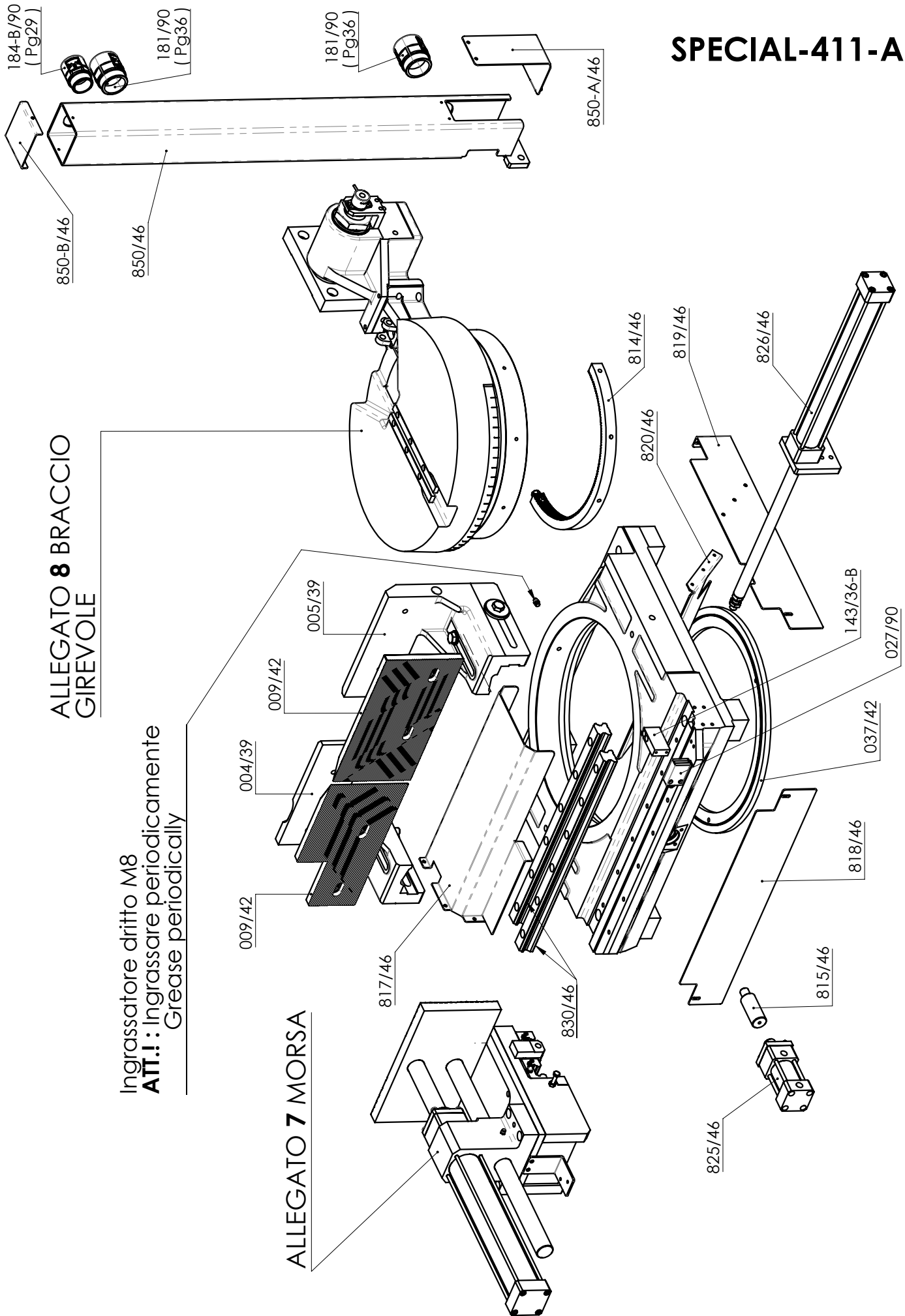

ALLEGATO 8 BRACCIO GIREVOLE

Ingrassatore dritto M8
ATT.! Ingrassare periodicamente
 Grease periodically

ALLEGATO 7 MORSA

SPECIAL-411-AG

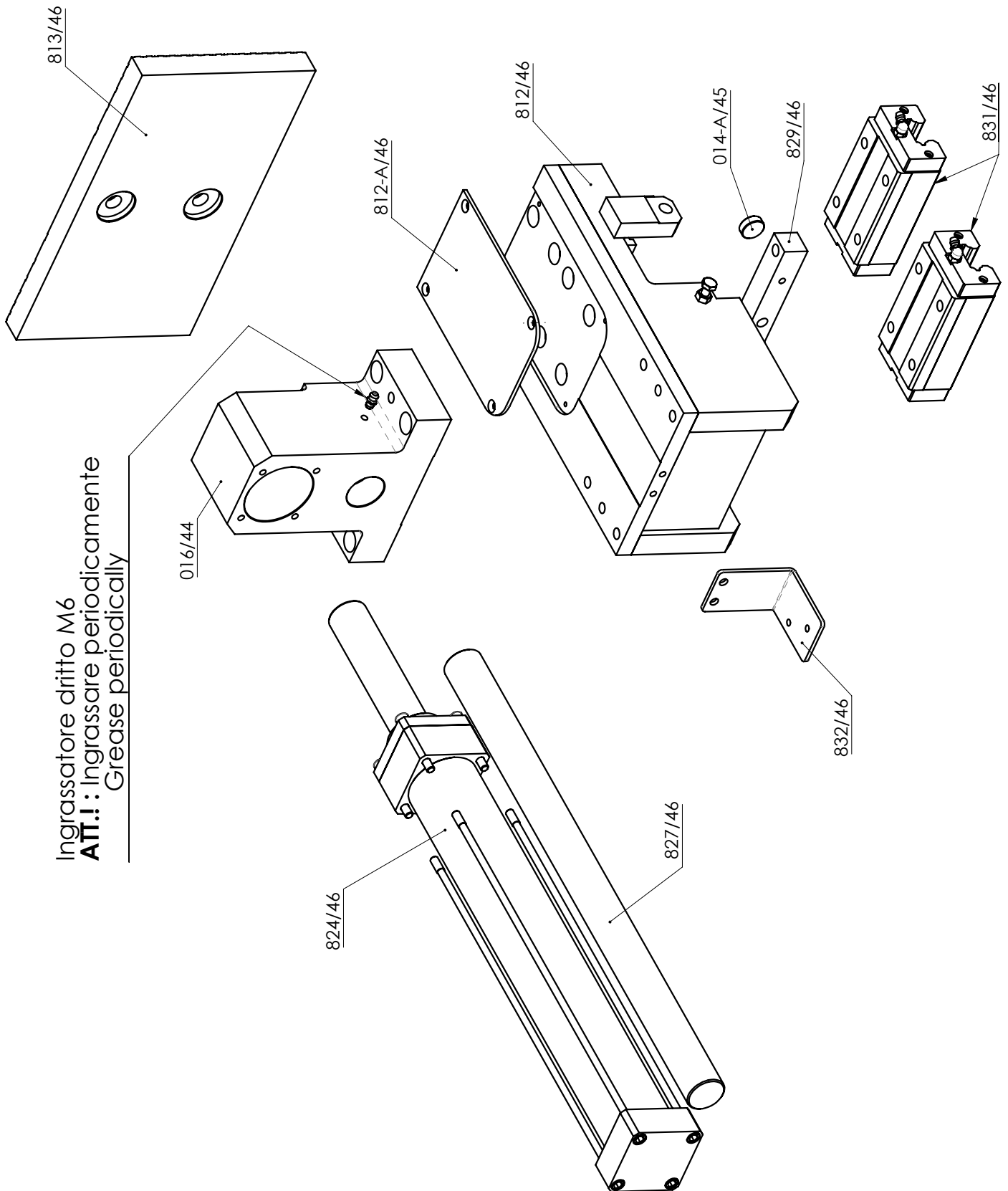

Ingrassatore dritto M6
ATT.! : Ingrassare periodicamente
Grease periodically

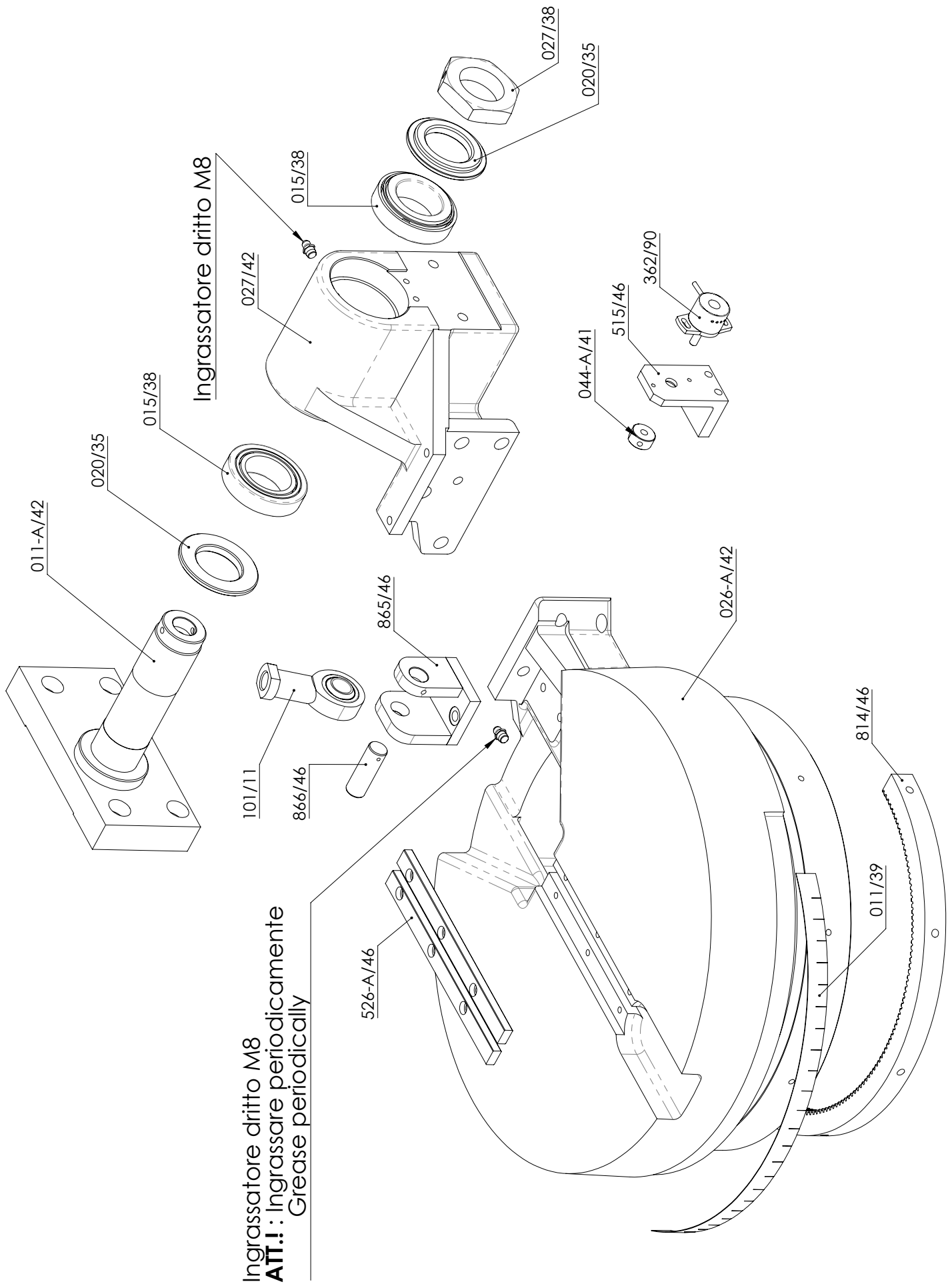

GUIDALAMA
MOBILE

MOBILE BLADE
GUIDE

GUIDE-LAME
MOBILE

BEW.
SÄGEBLATTFÜHRUNG

GUÍA-HOJA
MÓVIL

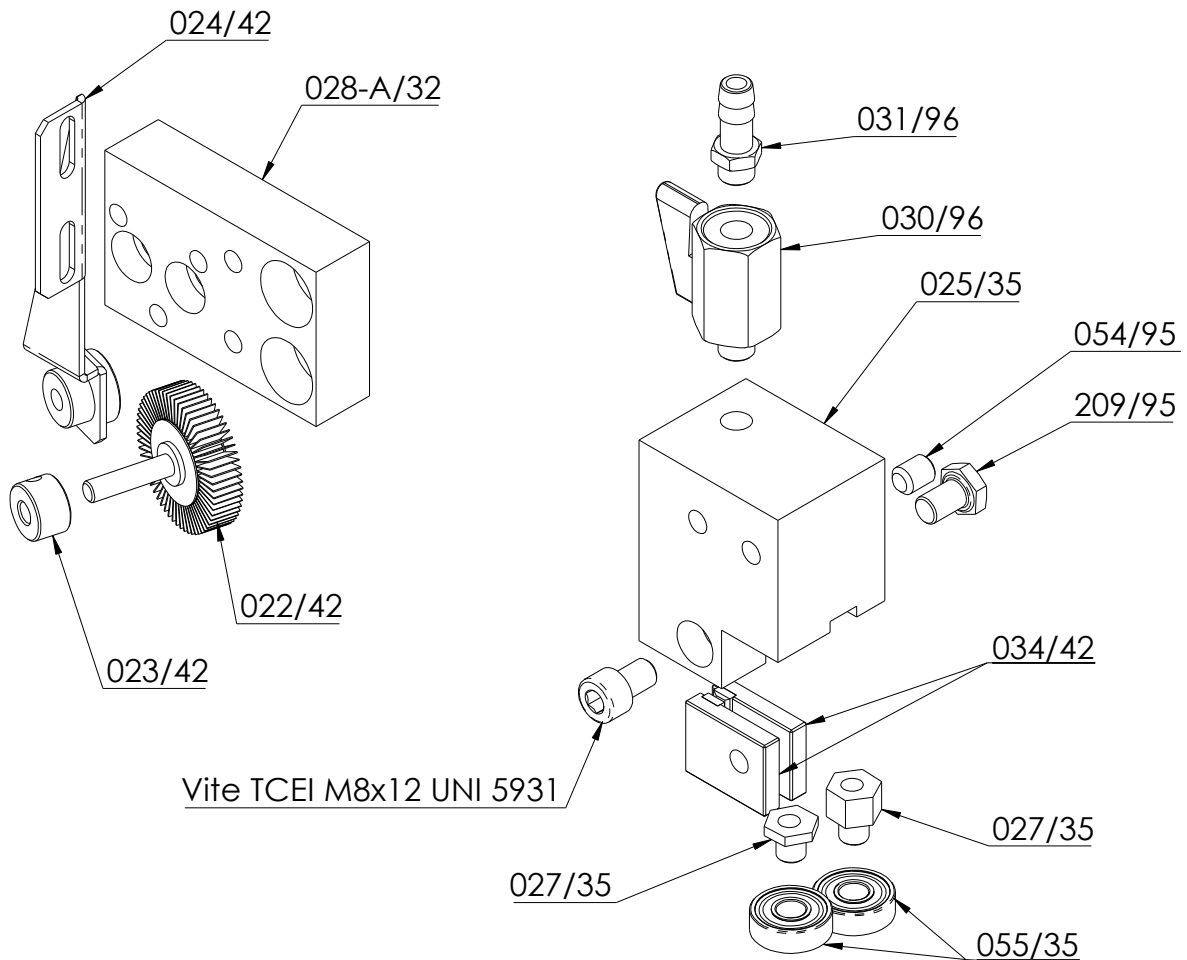
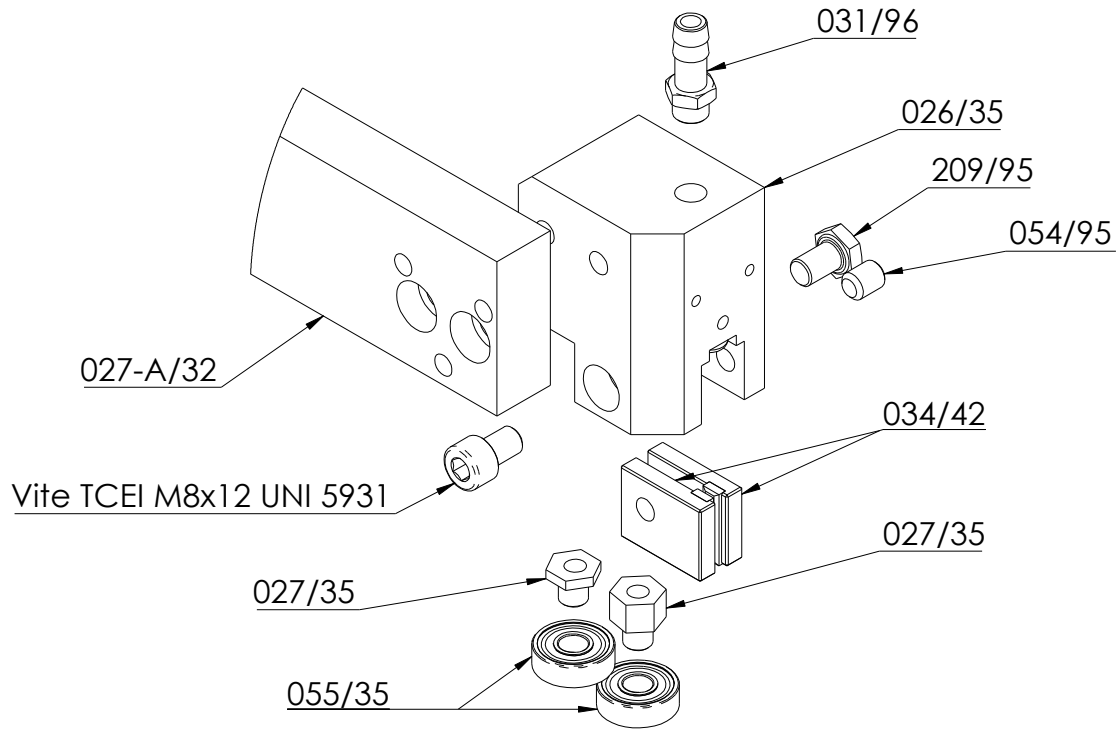

GUIDALAMA
FISSO

FIXED BLADE
GUIDE

GUIDE-LAME
FIXE

FEST.
SÄGEBLATTFÜHRUNG

GUÍA-HOJA
FIJO

SPECIAL-411-AG

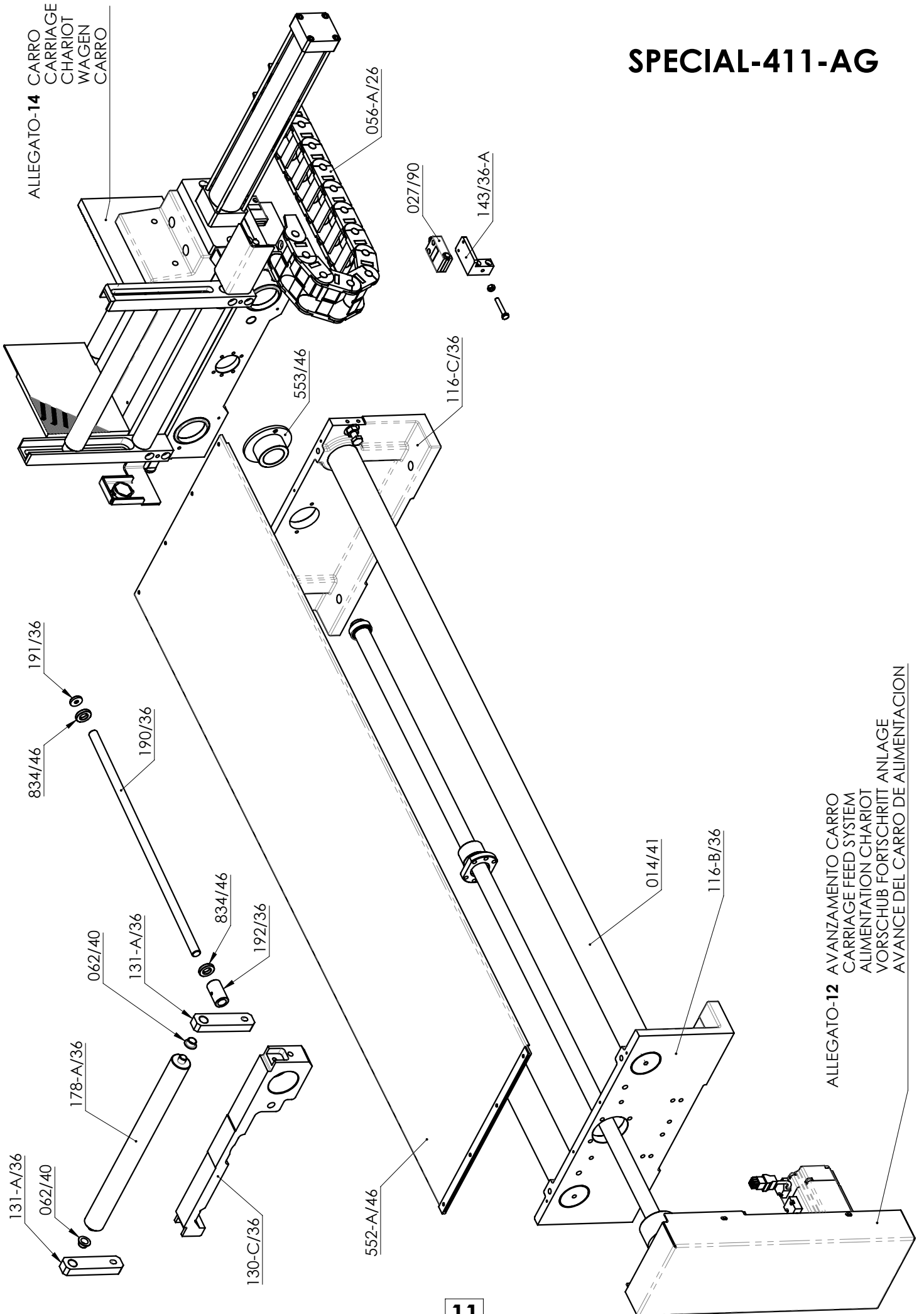

ALLEGATO-14 CARRO
CARRIAGE
CHARIOT
WAGEN
CARRO

ALLEGATO-12 AVANZAMENTO CARRO
CARRIAGE FEED SYSTEM
ALIMENTATION CHARIOT
VORSCHUB FORTSCHRITT ANLAGE
AVANCE DEL CARRO DE ALIMENTACION

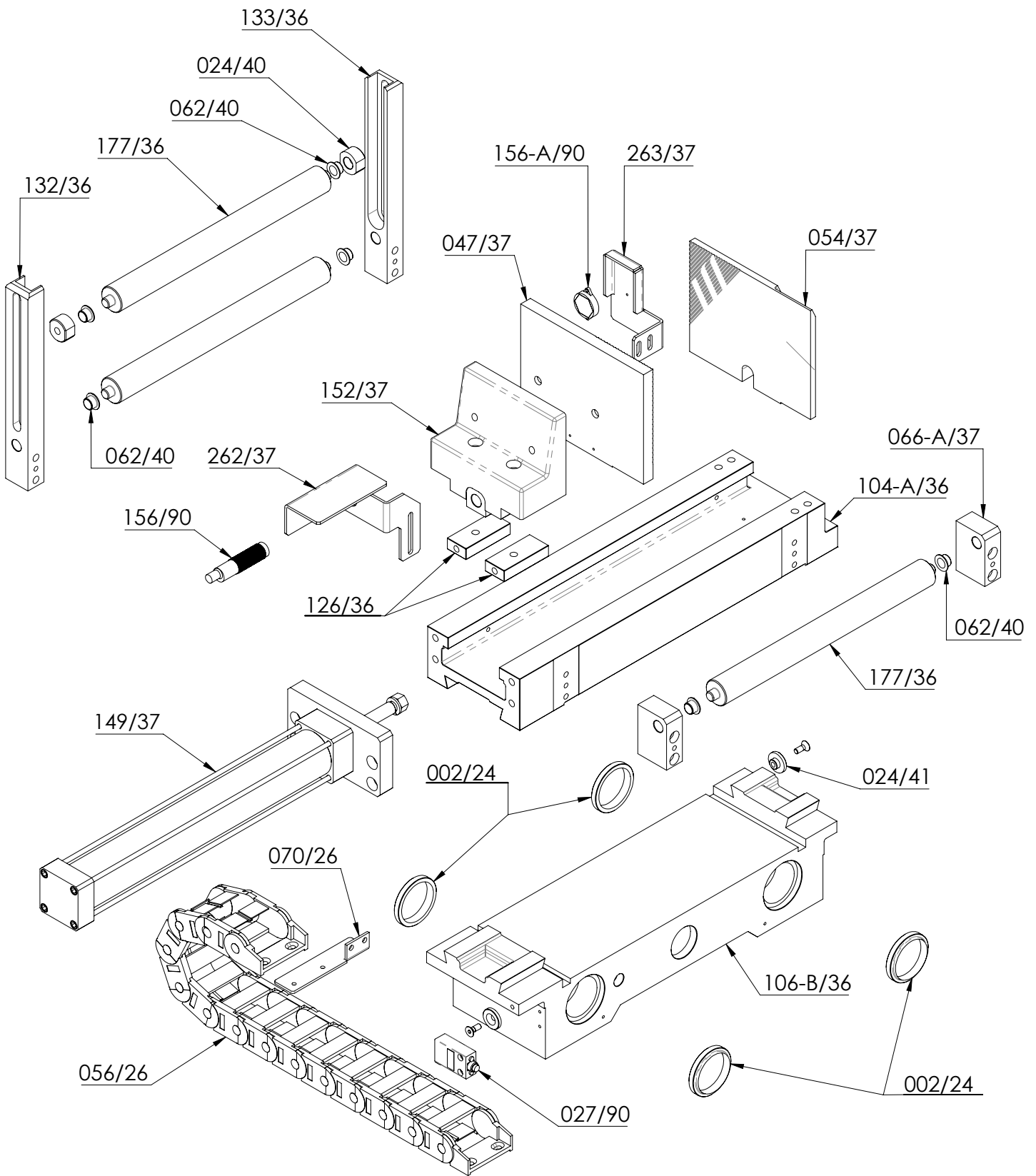

SPECIAL-411-AG

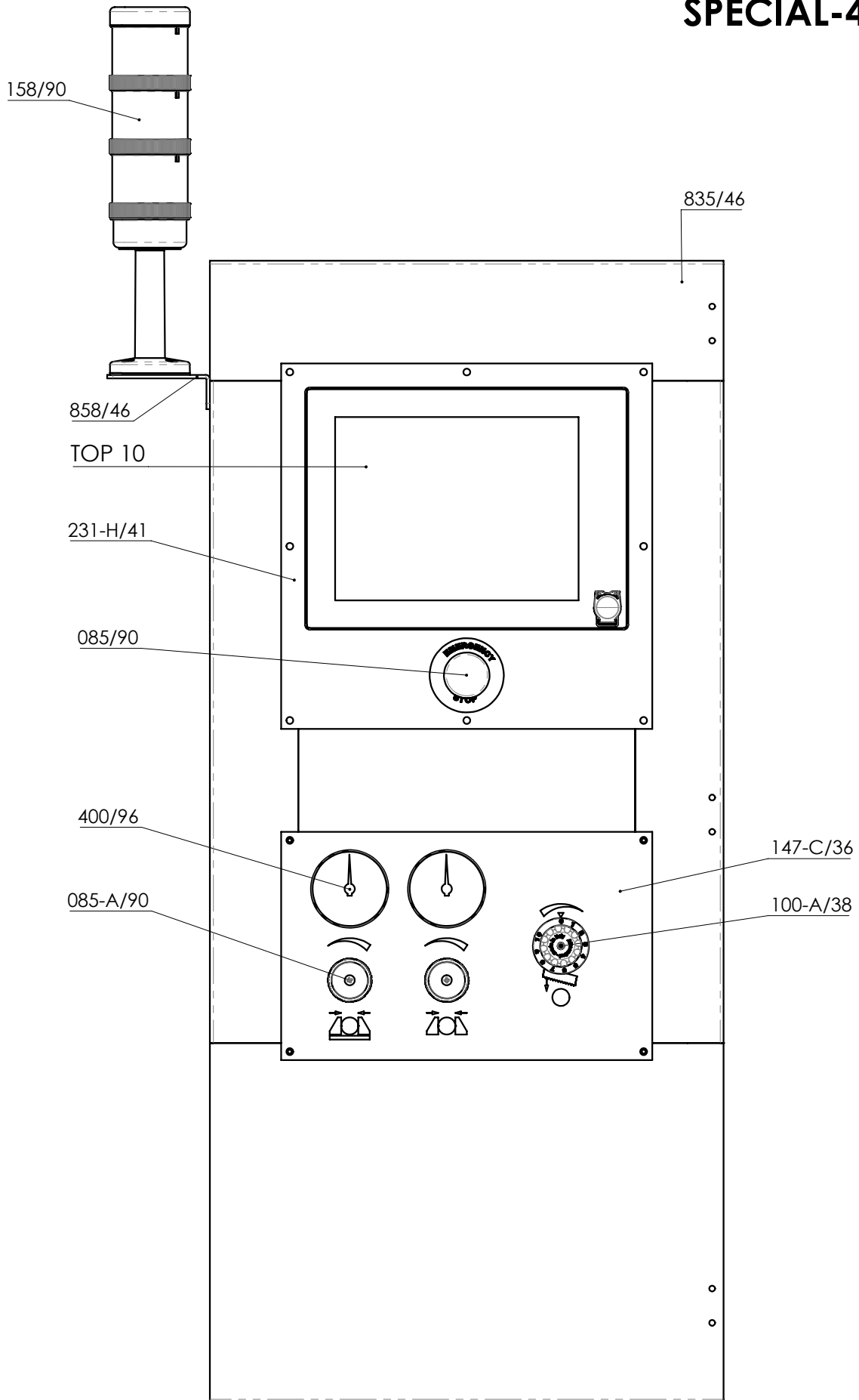

SPECIAL-411-AG

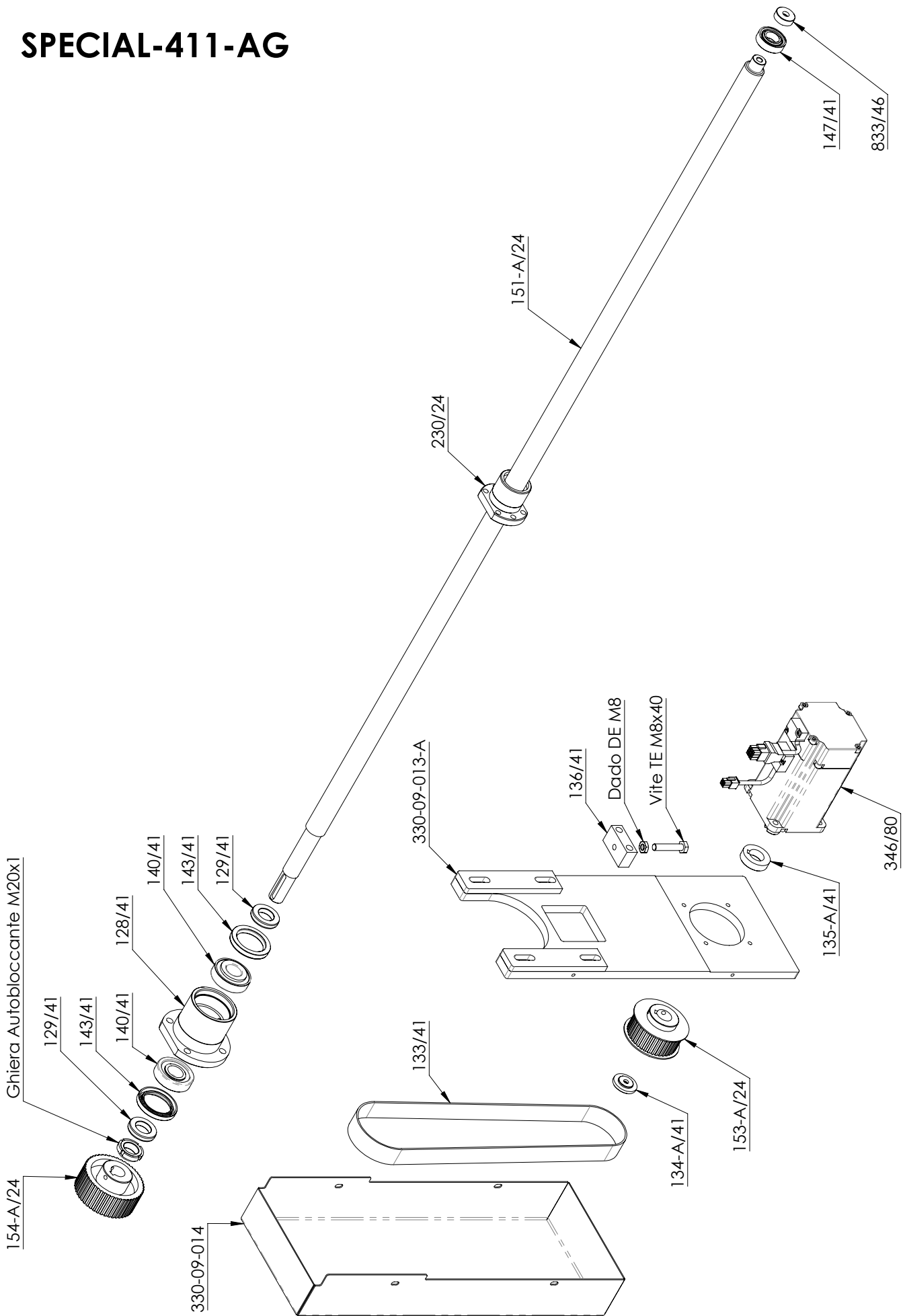

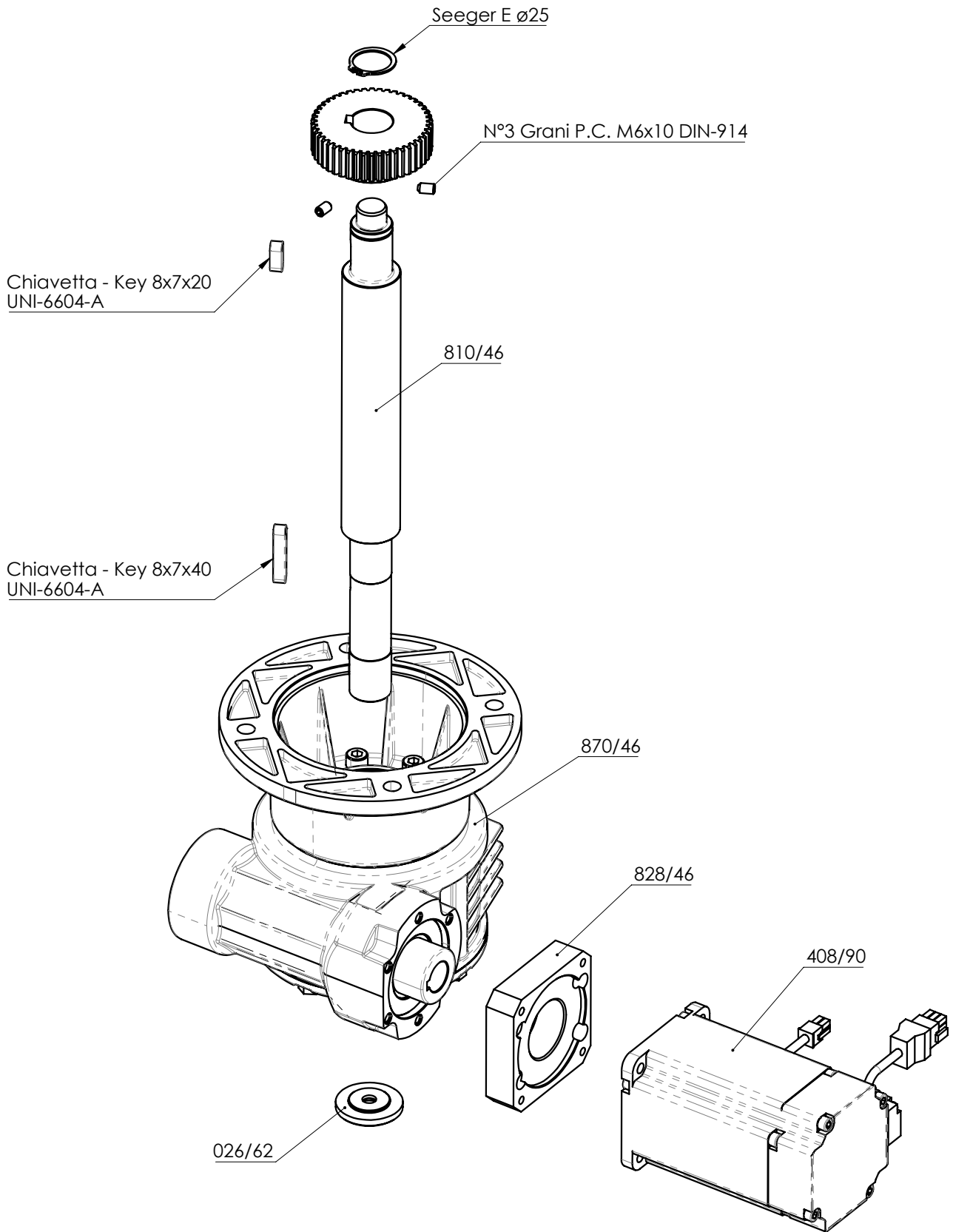

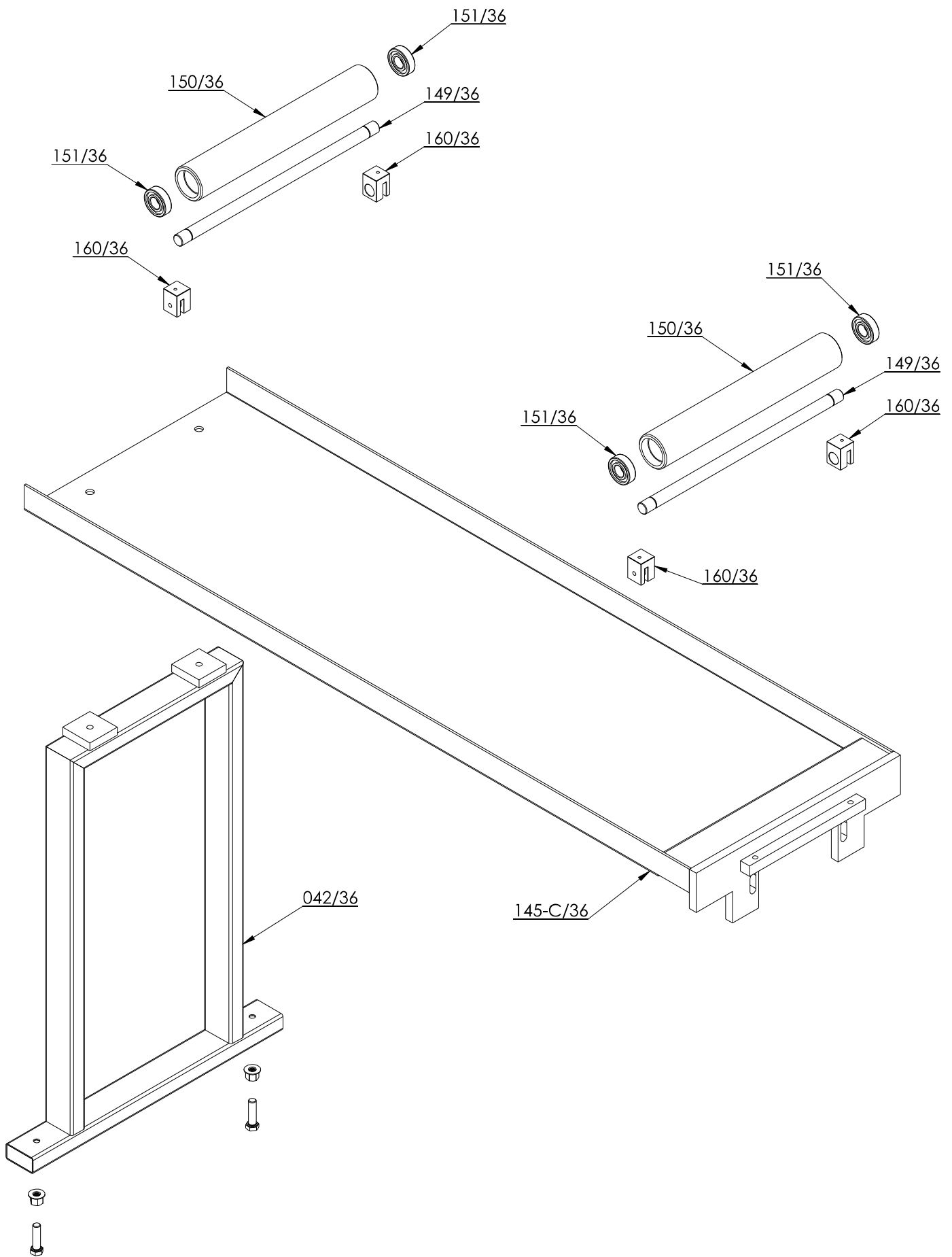

RULLIERA	ROLLER ARM	BRAS PORTE-ROULEAU	ROLLTRAGENARM	BRAZO PORTA-RODILLO
-----------------	-------------------	-------------------------------	----------------------	--------------------------------



	ITALIANO	ENGLISH	DEUTSCH
FR1	RELE' TERMICO MOTORE POMPA OLIO	THERMAL RELAY OIL PUMP MOTOR	THERMISCHES RELAIS OIL PUMPE MOTOR
FR2	RELE' TERMICO MOTORE LAMA	THERMAL RELAY BLADE MOTOR	THERMISCHES RELAIS SÄGEBLATTMOTOR
FR3	RELE' TERMICO MOTORE REFRIGERANTE	THERMAL RELAY COOLANT MOTOR	THERMISCHES RELAIS ÜHLMITTELMOTOR
FR4	RELE' TERMICO MOTORE ESTRATTORE TRUCIOLI	RELAY THERMAL CHIPS EXTRACTOR MOTOR	THERMISCHES RELAIS CHIP EXTRACTORMOTOR
FR5	RELE' TERMICO MOTORE GUIDA PEZZO	THERMAL RELAY GUIDA-PIECE MOTOR	THERMISCHES RELAIS Motor Führungsstück
FTC	FOTOCELLULA PRESENZA MATERIALE	MATERIAL PRESENCE PHOTOELECTRIC CELL	Photozelle Werkstoff Anwesenheit.
FU1	FUSIBILI PROTEZIONE TRASFORMATORE	FUSE TRANSFORMER PROTECTION	SICHERUNG TRAF0 SCHUTZ
FU2	FUSIBILI PROTEZIONE MOTORI	FUSE MOTOR PROTECTION	SICHERUNG MOTOR SCHUTZ
FU3	FUSIBILI PROTEZIONE POMPA REFRIGERANTE	FUSE COOLANT PUMP PROTECTION	SICHERUNG KÜHLMITTELPOMPE SCHUTZ
FU4	FUSIBILI PROTEZIONE ALIMENTATORE	FUSE FEEDER PROTECTION	SICHERUNG ZUFÜHRER SCHUTZ
FU5	FUSIBILI PROTEZIONE 24 V dc	FUSE 24 V dc PROTECTION	SICHERUNG 24 V dc SCHUTZ
FU6	FUSIBILI PROTEZIONE 24 V ac	FUSE 24 V ac PROTECTION	SICHERUNG 24 V ac SCHUTZ
FU7	FUSIBILE PROTEZIONE MOTORE INVERTER	FUSE INVERTER PROTECTION	GESCHWINDIGKEITUMRICHTER SICHERUNGSDRAHT
G	GALLEGGIANTE	FLOAT	SCHWIMMER
H1	SPIA PRESENZA LINEA	SPY LINE PRESENCE	LINE PRÄSENZ LAMPE
H2	SPIA LAMA IN TENSIONE	SPY BLADE IN TENSION	BLATT TENSION LAMPE
H3	SPIA START CICLO	SPY CYCLE START	ZYKLUS START LAMPE
K	TELERUTTORE TERMORESISTENZA	THERMO-RESISTANCE CONTROL SWITCH	KONTAKTGEBER WIDERSTANDSTHERMOMETER
KM0	TELERUTTORE ALIMENT. INVERTER	INVERTER FEEDING CONTROL SWITCH	Fernschalter Frequenzumrichter Versorgung
KM1	TELERUTTORE MOTORE POMPA OLIO	OIL PUMP MOTOR REMOTE CONTROL SWITCH	KONTAKTGEBER ZENTRALHYDRAULIK MOTOR
KM2	TELERUTTORE MOTORE LAMA	BLADE MOTOR REMOTE CONTROL SWITCH	KONTAKTGEBER SÄGEBLATTMOTOR
KM3	TELERUTTORE POMPA REFRIGERANTE	COOLANT PUMP REMOTE CONTROL SWITCH	KONTAKTGEBER KÜHLMITTELPUMPE
KM4	TELERUTTORE ESTRATTORE TRUCIOLI (COCLEA)	CHIP EXTRACTOR CONTROL SWITCH	KONTAKTGEBER SPÄNE AUSZIEHER
KM5	TELERUTTORE MOTORE GUIDA PEZZO	THERMAL RELAY GUIDA-PIECE MOTOR CONTROL SWITCH	KONTAKTGEBER Motor Führungsstück
KM6	TELERUTTORE POMPA RECUPERO REFRIGERANTE	COOLANT RECYCLE PUMP THERMAL RELAY	KONTAKTGEBER KUEHLMITTELPUMPE
M1	MOTORE POMPA OLIO	OIL PUMP MOTOR	ZENTRALHYDRAULIKMOTOR
M2	MOTORE LAMA	BLADE MOTOR	SÄGEBLATTMOTOR
M3	MOTORE POMPA REFRIGERANTE	COOLANT PUMP MOTOR	KÜHLMITTELPUMPE MOTOR
M4	MOTORE ESTRATTORE TRUCIOLI	CHIP EXTRACTOR MOTOR	SPAENEAUSLASSVORRICHTUNG MOTOR
M5	MOTORE ROTAZIONE TESTA	SAWHEAD ROTATION MOTOR	DREHUNGS KOPF MOTOR
M50	MOTORE GUIDA PEZZO	GUIDA-PIECE MOTOR	FÜHRUNGSSTÜCK MOTOR



M6	MOTORE AVANZAMENTO MATERIALE	MATERIAL FEEDING OTOR	VORSCHUBMATERIAL MOTOR
P1	POTENZIOMETRO POSIZIONAMENTO LAMA	BLADE POSITIONING POTENTIOMETER	SÄGEBLATT-STENUNG POTENZIOMETER
P2	POTENZIOMETRO VELOCITA' LAMA	BLADE SPEED POTENTIOMETER	SÄGEBLATT-GESCHWINDIGKEIT POTENZIOMETER
PX1	SENSORE ROTAZIONE LAMA	BLADE ROTATION SENSOR	BLATT UMDREHUNGSSENSOR
QS1	INTERRUPTORE GENERALE	MAIN ON / OFF SWITCH	HAUPTSCHALTER
QS2	INTERRUPTORE / COMMUTATORE DI VELOCITA'	SWITCH / SPEED CHANGE OVERSWITCH	SCHALTER / GESCHWINDIGKEIT UMSCHALTER
QS3	INTERRUPTORE POMPA REFRIGERANTE	COOLANT PUMP SWITCH	KÜHLMITTELpumpe SCHALTER
R	RELE' COMANDO MARCIA ROTAZIONE LAMA	ROTATING BLADE COMMAND RELAY	SÄGEBLATT UMDREHUNG POTENZIOMETER
R1	RELE' COMANDO TELERUTTORE POMPA OLIO	OIL PUMP REMOTE CONTROL SWITCH COMMAND RELAY	RELAIS OIL PUMPE FERNSCHALTER
R10	RELE' PRESSINO ON	VERTICAL VICE RELAY	SENKRECHT SCHRAUBSTOCK RELE
R2	RELE' COMANDO TELERUTTORE LAMA	BLADE REMOTE CONTROL SWITCH COMMAND RELAY	RELAIS BLATT FERNSCHALTER
R5	RELE' COMANDO MICROLUBRIFICAZIONE	MICROLUBRICATION COMMAND RELAY	MIKROSPRÜHEINRICHTUNGSTEUER RELAIS
RT	RELE' TEMPORIZZATORE	TIMER RELAY	ZEITGEBER RELE
RX	RELE' COMANDO TERMOSTATO	THERMOSTAT COMMAND RELAY	THERMOSTATSTEUER RELAIS
RYV5	RELE' DISCESA LAMA	BADE DESCENT RELAY	SAEGEBLATT ABSTIG RELE
S	SELETTORE FUNZIONE	FUNCTION SELECTOR	FUNKTION WÄHLER
S10	SELETTORE PRESSINO ON	VERTICAL VICE ON CHANGEOVER SWITCH	GESCHWINDIGKEITUMRICHTER WAEHLER ON
S4	SELETTORE CAMBIO LAMA	BLADE RELACEMENT CHANGEOVER SWITCH	SAEGEBLATT WAEHLERSCHALTER
SB1	PULSANTE DI ARRESTO EMERGENZA	EMERGENCY PUSH BUTTON	NOT AUS TASTER
SB11	PULSANTE DETENSIONAMENTO LAMA	BLADE DETENSIONING BUTTON	SAEGEBLATT ENSPANNSCHALTER
SB12	PULSANTE TENSIONAMENTO LAMA	BLADE TENSIONING BUTTON	SAEGEBLAT SPANNSCHALTER
SB2	PULSANTE START CICLO	CYCLE START BUTTON	ZYKLUS START TASTER
SB3	PUSANTE DI RESET	RESET BUTTON	RESETTASTER
SB4	PULSANTE CHIUSURA MORSA	LOCK VICE BUTTON	SPANNSOCH SCHLIEß TASTER
SB5	PULSANTE APERTURA MORSA	OPEN VICE BUTTON	SPANNSTOCK ÖFFNUNG TASTER
SB6	PULSANTE DI SALITA	BUTTON UP	OBEN TASTER
SB7	PULSANTE DI DISCESA	BUTTON DOWN	HINTEN TASTER
SB8	PULSANTE REFRIGERANTE "ON"	REFRIGERANTE BUTTON "ON"	KÜHLUNG EIN TASTER
SB9	PULSANTE MEMORY	MEMORY BUTTON	MEMORY TASTER
SB90	PULSANTE DI SBLOCCO	RELEASE BUTTON	AUSLOESER TASTE
SQ02	MICROINTERUTTORE CARTER APERTO SX	COVER OPEN MICROSWITCH	SCHUTZ GEÖFFNET ENDSCHALTER
SQ1	MICROINTERUTTORE ROTTURA LAMA	MICROSWITCH BLADE FAILURE	ENDSCHALTER BLATT GEBROCHEN



SQ10	MICROINTERRUTTORE START A PEDALE	PEDAL MICROSWITCH START	PEDALS MIKROSCHALTER
SQ11	MICROINTERRUTTORE CHIUSURA MORSA A PEDALE	PEDAL VICE CLOSING MICROSWITCH	FußSCHALTER SPENNSTOCK SCHLIEßEN MIKROSCHALTER
SQ15	FINECORSА GUIDA PEZZO AVANTI	MICROSWITCH GUIDE-PIECE FORWARD	ENDSCHALTER FÜHRUNGSSTÜCK NACH VORNE
SQ16	FINECORSА GUIDA PEZZO INDIETRO	MICROSWITCH GUIDE-PIECE BACKWARD	ENDSCHALTER FÜHRUNGSSTÜCK NACH HINTEN
SQ18	FINECORSА SOLLEVATORE ALTO	MICROSWITCH LIFT UP POSITION	HEBEWERK NACH OBEN ENDSCHALTER
SQ2	MICROINTERRUTTORE CARTER APERTO	MICROSWITCH PROTECTION CASE	ENDSCHALTER SCHUTZGEHÄUSE
SQ20	PRESSOSTATO CHIUSURA MORSA	VICE PRESSURE SWITCH	SPANNDRUCK TASTE
SQ3	FINECORSА CARRO AVANTI	MICROSWITCH CARRIAGE FORWARD	ENDSCHALTER WAGEN VORNE
SQ30	FINECORSА ROTAZIONE -45°	MICROSWITCH -45° ROTATION	-45° UMDREHUNG ENDSCHALTER
SQ4	FINECORSА CARRO INDIETRO	MICROSWITCH CARRIAGE BACK	ENDSCHALTER WAGEN ZURÜCK
SQ5	FINECORSА TESTA ALTA	MICROSWITCH HEAD / BOW UP	ENDSCHALTER BÜGEL NACH OBEN
SQ6	FINECORSА TESTA BASSA	MICROSWITCH HEAD / BOW DOWN	ENDSCHALTER BÜGEL NACH UNTEN
SQ7	MICROINTERRUTTORE FINE MATERIALE	MICROSWITCH BAR END	ENDSCHALTER STANGENENDE
SQ70	PROSSIMITI PRESENZA PEZZO	MICROSWITCH PIECE PRESENCE	STÜCKANWESENDEHEIT ENDSCHALTER
SQ8	MICROINTERRUTTORE MANIGLIONE	MICROSWITCH HANDLE	ENDSCHALTER GRIFF
SQ9	MICROINTERRUTTORE START MANUALE	MICROSWITCH MANUAL START	ENDSCHALTER MANUELL START
T	TEMPORIZZATORE	TIMER	ZEITGEBER
TC1	TRASFORMATORE	TRANSFORMER	TRANSFORMATOR
TR	TERMOSTATO	THERMOSTAT	THERMOSTAT
TR	TERMORESISTENZA	THERMO-RESISTANCE	THERMO-WIDERSTAND
YV1	ELETTROVALVOLA CARRO AVANTI LENTO	CARRIAGE SLOW FORWARD MOTION SOLENOID VALVE	ELEKTROVENTIL WAGEN LANGSAM VORNE
YV10	ELETTROVALVOLA SBLOCCAGGIO MANUALE	MANUAL UNLOCKING SOLENOID VALVE	ELEKTROVENTIL MANUELL AUFHEBUNG
YV11	ELETTROVALVOLA DETENSIONAMENTO LAMA	UNTIGHTNING BLADE SOLENOID VALVE	SAEGBLATT ENTSPANNUNG MAGNETVENTIL
YV11	ELETTROVALVOLA DETENSIONAMENTO LAMA	BLADE DETENSIONING SOLENOID VALVE	ELETRISCHESVETIL SAEGBLATT ENSPANNUNG
YV12	ELETTROVALVOLA TENSIONAMENTO LAMA	TIGHTNING BLADE SOLENOID VALVE	SAEGBLATT SPANNUNG MAGNETVENTIL
YV12	ELETTROVALVOLA TENSIONAMENTO LAMA	BLADE TENSIONING SOLENOID VALVE	ELETRISCHESVENTIL SAEGBLATT SPANNUNG
YV15	ELETTROVALVOLA SOLLEVATORE CARICATORE	LOADER LIFT SOLENOID VALVE	LADEMAGAZIN HEBEWERK ELEKTROVENTIL
YV16	ELETTROVALVOLA MORSA CARICATORE	LOADER VICE SOLENOID VALVE	LADEMAGAZINSPANNSTOCK ELEKTROVENTIL
YV18	ELETTROVALVOLA GIUDA PEZZO AVANTI	GUIDE-PIECE FORWARD VALVE	ELEKTROVENTIL ZAUN NACH VORNE
YV19	ELETTROVALVOLA GUIDA PEZZO INDIETRO	GUIDE-PIECE BACKWARD VALVE	ELEKTROVENTIL HINTEREN ZAUN
YV2	ELETTROVALVOLA CARRO INDIETRO LENTO	CARRIAGE SLOW BACK MOTION SOLENOID VALVE	ELEKTROVENTIL WAGEN LANGSAM ZURÜCK
YV20	SBLOCCAGGIO ROTAZIONE	ROTATION UNLOCK	UMDREHUNG LOSMACHEN



YV3	ELETTROVALVOLA MORSA MOBILE	MOVABLE VICE SOLENOID VALVE	ELEKTROVENTIL BEWEGLICHER SPANNSTOCK
YV30	ELETTROVALVOLA MORSA MOBILE CHIUDE	CLOSE MOVABLE VICE VALVE	BEW. SPANNSTOCK SCHLIEß ELEKTROVENTIL
YV30P	ELETTROVALVOLA PRESSINO CARRO	CARRIAGE VICE SOLENOID VALVE	ELETRISCHESVENTIL SCHRAUBSTOCK VORSCHUBWAGEN
YV31	ELETTROVALVOLA RUOTA ARCO LENTO	SLOW BOW ROTATION SOLENOID VALVE	LANGSAM SÄGEARMUMDREHUNG ELEKTROVENTIL
YV37	ELETTROVALVOLA RUOTA DX	ROTATION LEFTWARDS SOLENOID VALVE	UMDREHUNG LINKS ELEKTROVENTIL
YV38	ELETTROVALVOLA RUOTA SX	ROTATION RIGHTWARDS SOLENOID VALVE	UMDREHUNG RECHTS ELEKTROVENTIL
YV4	ELETTROVALVOLA SALITA	UP STROKE SOLENOID VALVE	ELEKTROVENTIL ANSTIEG
YV5	ELETTROVALVOLA DISCESA	DOWN STROKE SOLENOID VALVE	ELEKTROVENTIL ABSTIEG
YV50	ELETTROVALVOLA DISCESA LAMA RAPIDA	QUICK LOWERING SOLENOID VALVE	SCHNELL ELEKTROVENTIL ABSTIEG
YV6	ELETTROVALVOLA APERTURA MORSA FISSA	FIXED VICE OPENING SOLENOID VALVE	ELEKTROVENTIL FESTER SPANNSTOCK ÖFFNUNG
YV60	ELETTROVALVOLA CHIUSURA MORSA FISSA	FIXED VICE CLOSING SOLENOID VALVE	ELEKTROVENTIL FESTER SPANNSTOCK SCHLIESSEN
YV60P	ELETTROVALVOLA PRESSINO FISSO	FIXED VICESOLENOID VALVE	ELETRISCHESVENTIL FESTSCHRAUBSTOCK
YV61	ELETTROVALVOLA SPAZZOLA	BRUSH VALVE	BÜRSTE ELEKTROVENTIL
YV62	ELETTROVALVOLA ATTIVAZIONE 2a POMPA OLIO	SECOND OIL PUMP	ZWEITE ÖLPUMPE EIN ELEKTROVENTIL
YV7	ELETTROVALVOLA CARRO AVANTI	CARRIAGE FORWARD SOLENOID VALVE	ELEKTROVENTIL WAGEN VORNE
YV70	ELETTROVALVOLA SPAZZOLA	BRUSH SOLENOID VALVE	BUERSTE MAGNETVENTIL
YV8	ELETTROVALVOLA CARRO INDIETRO	CARRIAGE BACK SOLENOID VALVE	ELEKTROVENTIL WAGEN ZURÜCK
YV9	ELETTROVALVOLA BLOCCO	MANUAL LOCKING SOLENOID VALVE	ELEKTROVENTIL BLOCK
YV90	ELETTROVALVOLA MICROLUBRIFICAZIONE	MICROLUBRICATION SOLENOID	MIKROSPRÜHEINRICHTUNG ELEKTROVENTIL

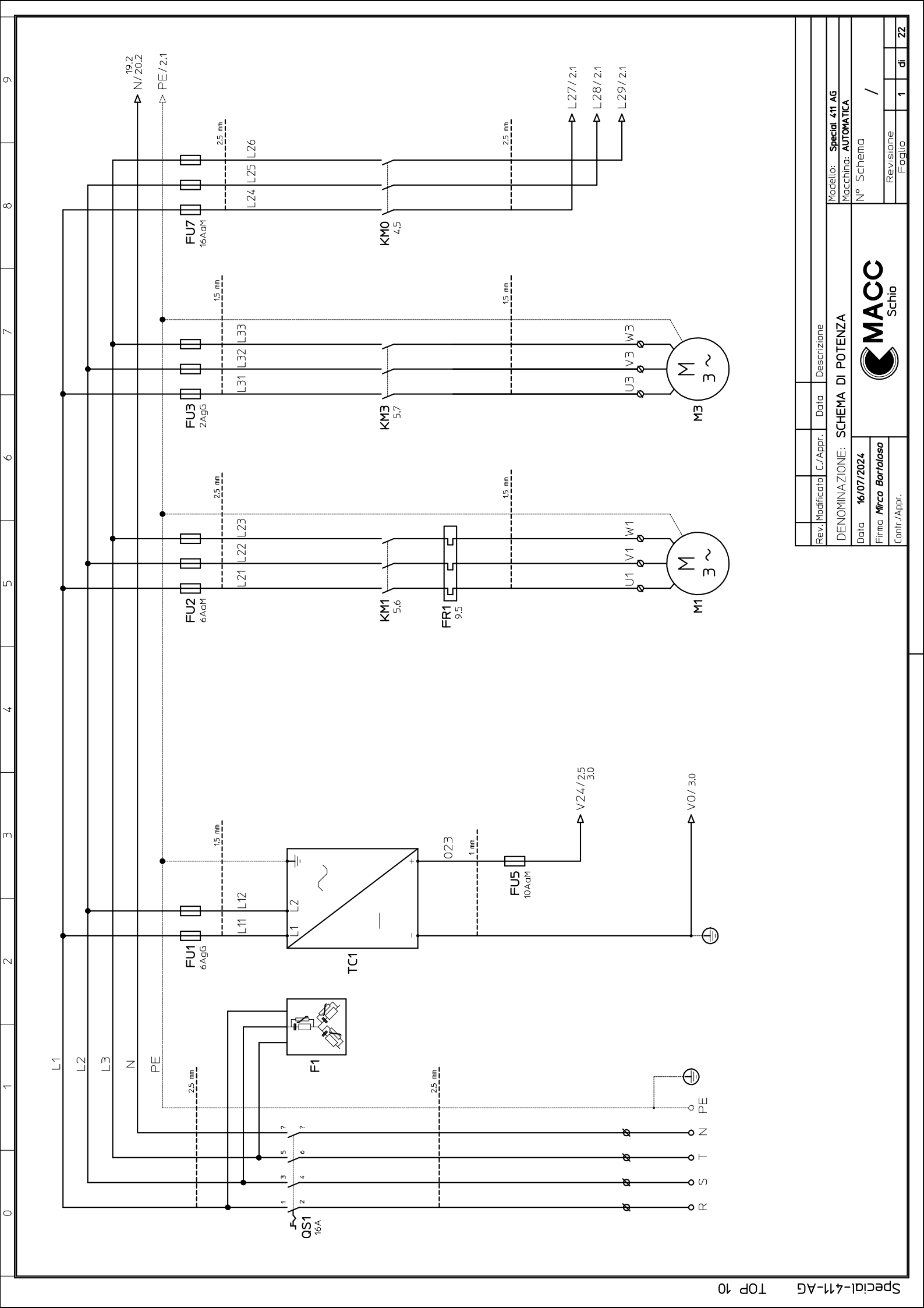

0	1	2	3	4	5	6	7	8	9
---	---	---	---	---	---	---	---	---	---

Rev./Modificato	C./Appr.	Data	Descrizione
DENOMINAZIONE: SCHEMA DI POTENZA			Modello: Special 411 AG
Data 16/07/2024			Macchina: AUTOMATICA
Firma <i>Mirco Bartoloso</i>			N° Schema /
Contr./Appr.			Revisione
			Foglio
			1
			di
			22



0 1 2 3 4 5 6 7 8 9

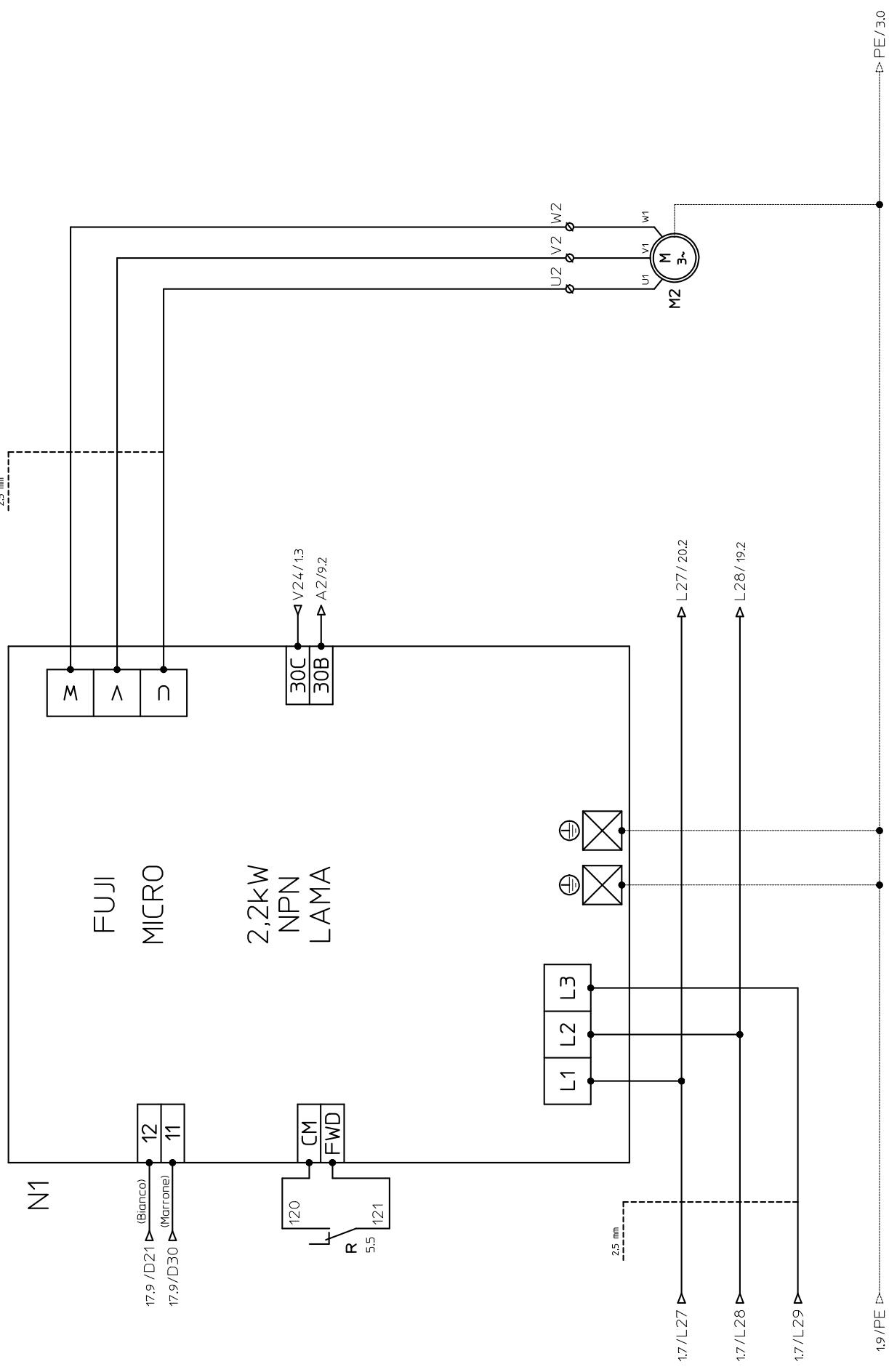

Rev.	Modificato	C./Appr.	Data	Descrizione
				DENOMINAZIONE: SCHEMA INVERTER LAMA
				Modello: Special 411 AG
				Macchina: AUTOMATICA
				N° Schema /
				Revisione
				Foglio
				2
				di
				22



Data 16/07/2024
 Firma *Mirco Bartaloso*
 Contr./Appr.

0 1 2 3 4 5 6 7 8 9

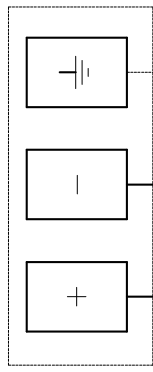

POWER
24 VDC
013

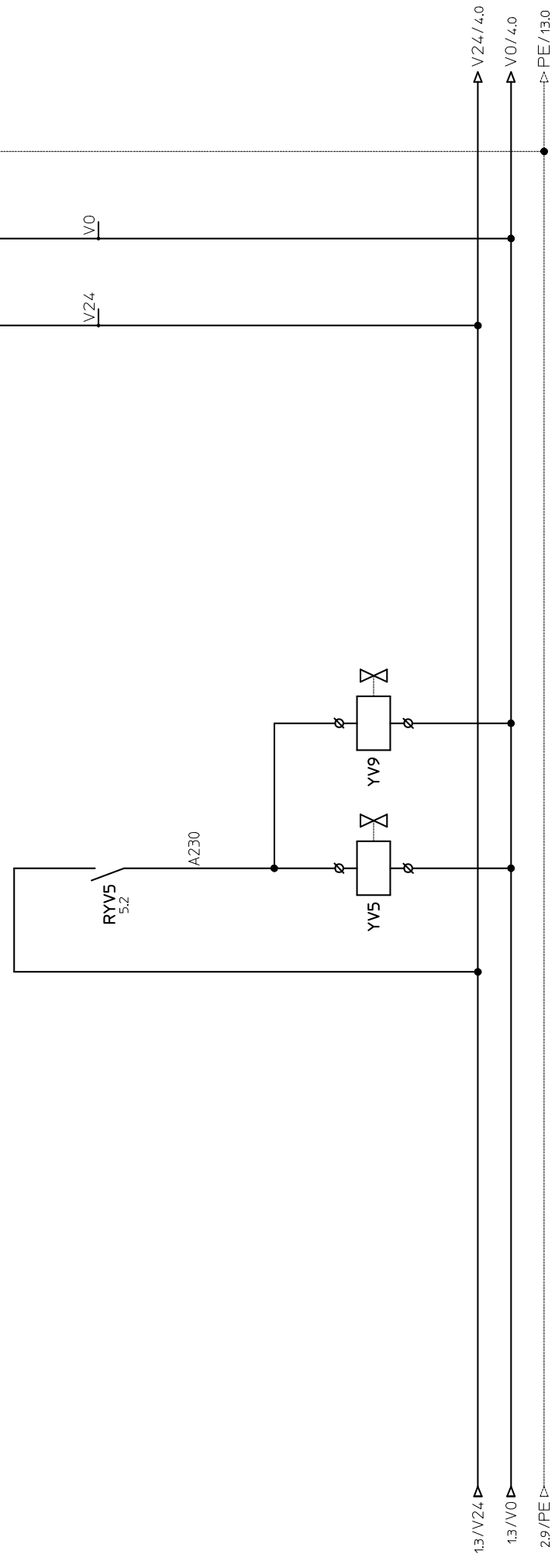

Rev./Modificato	C./Appr.	Data	Descrizione
DENOMINAZIONE: SCHEMA COMANDO			Modello: Special 411 AG
Data 16/07/2024			Macchina: AUTOMATICA
Firma <i>Micro Bartoloso</i>			N° Schema /
Contr./Appr.			Revisione
			Foglio
			3 di
			22



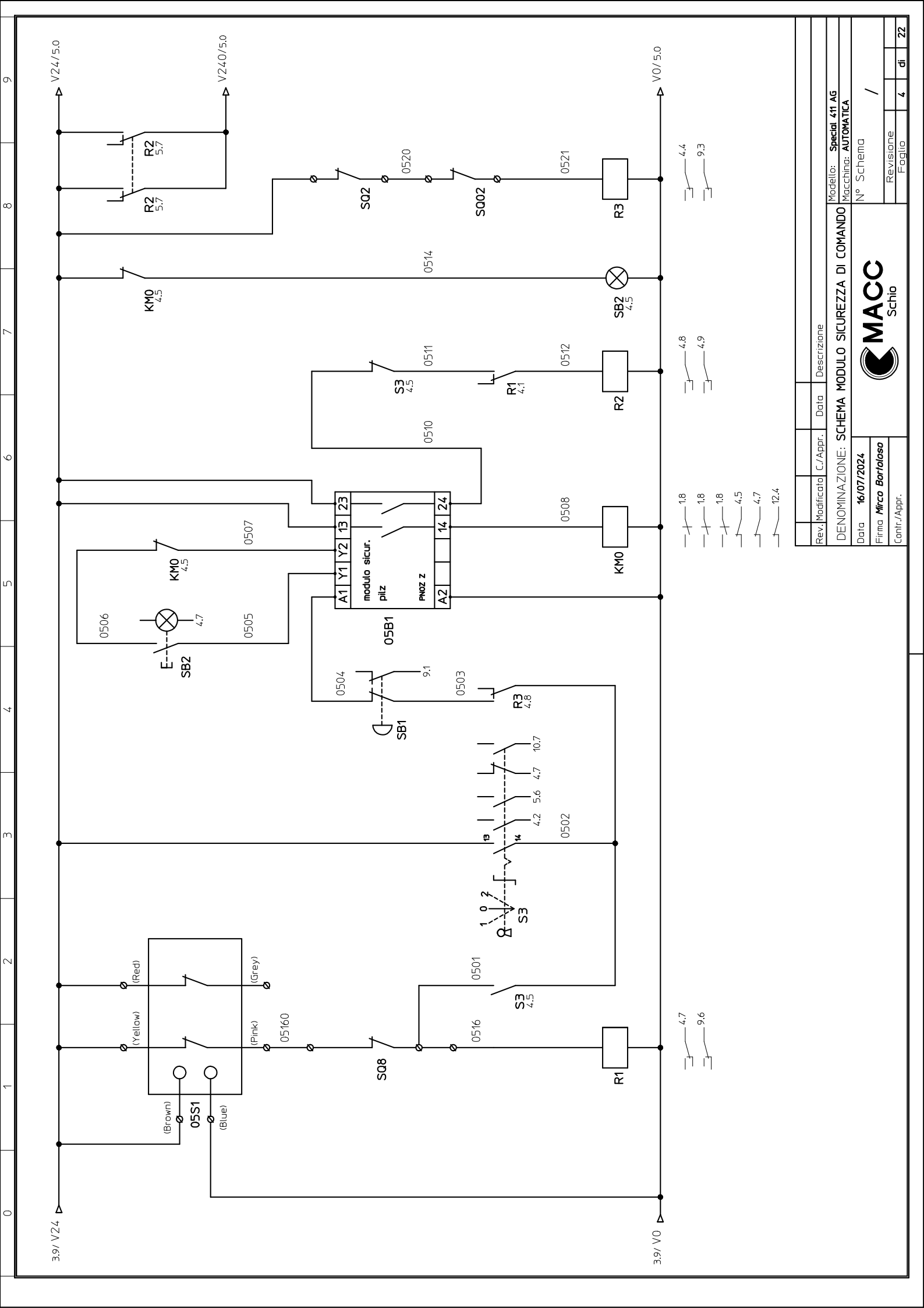

Rev./Modificato	C./Appr.	Data	Descrizione
			Modello: Special 411 AG
			Macchina: AUTOMATICA
DENOMINAZIONE: SCHEMA MODULO SICUREZZA DI COMANDO			
Data 16/07/2024			
Firma <i>Mirco Bartoloso</i>			
Contr./Appr.			
N° Schema /			
Revisione	Foglio	di	22
4	4		



A
022

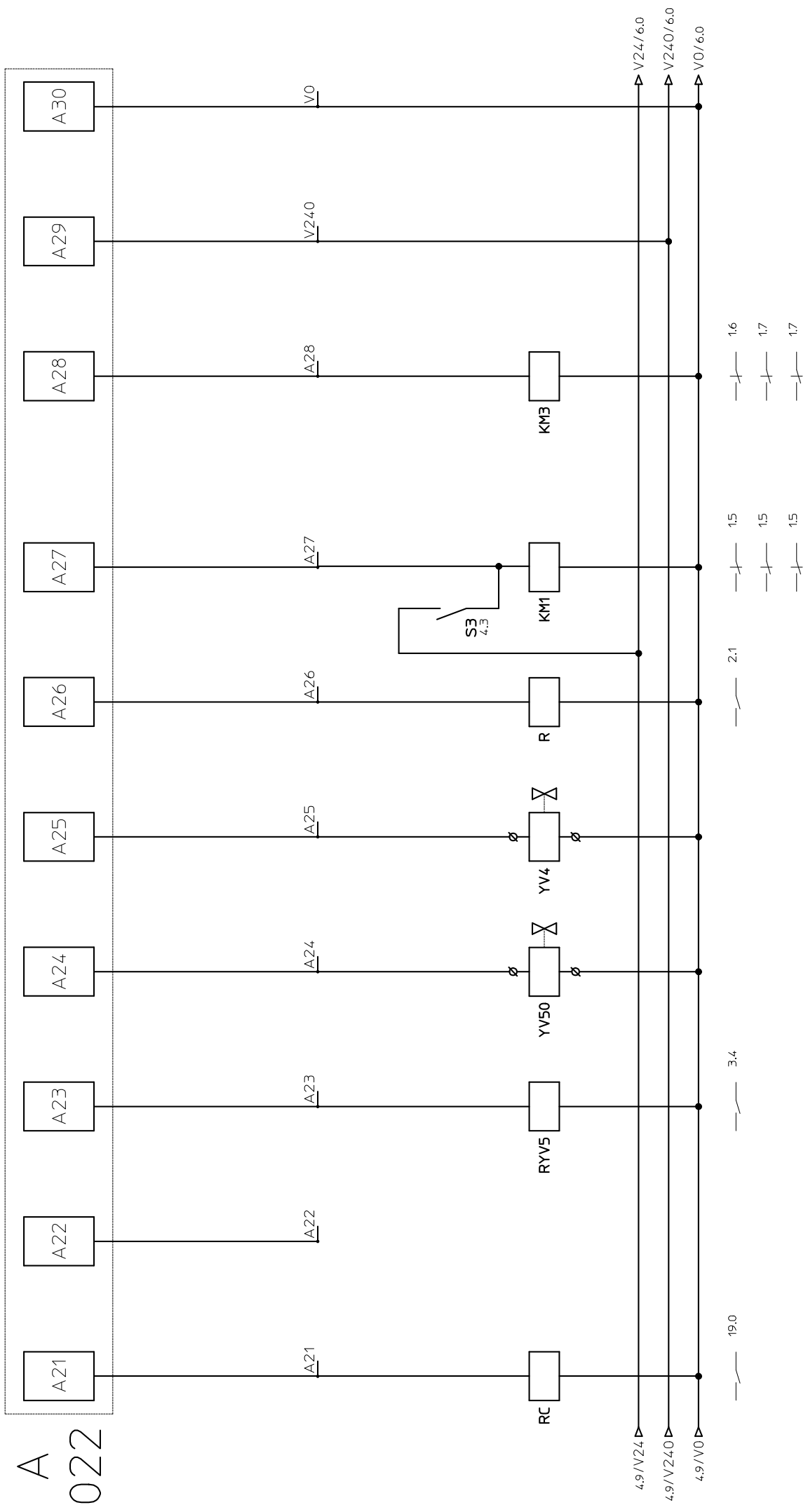

Rev./Modificato	C./Appr.	Data	Descrizione
			Modello: Special 411 AG
			Macchina: AUTOMATICA
			N° Schema /
			Revisione
			Foglio
			5
			di
			22

DENOMINAZIONE: SCHEMA DI COMANDO OUTPUT

Data 16/07/2024

Firma *Micro Bartoloso*

Contr./Appr.



A
022

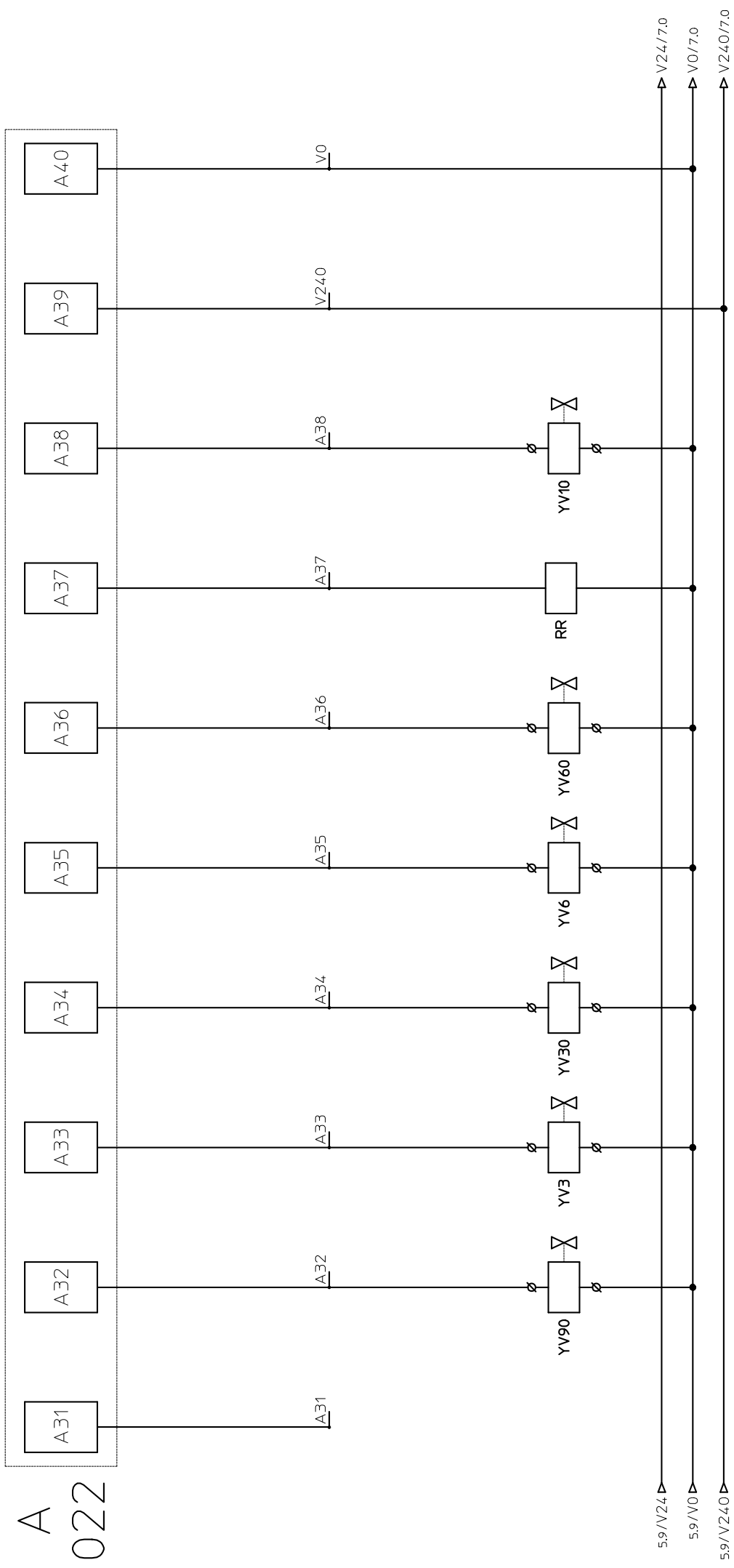

Rev./Modificato	C./Appr.	Data	Descrizione
			Modello: Special 411 AG
			Macchina: AUTOMATICA
			N° Schema /
			Revisione
			Foglio
			6
			di
			22

DENOMINAZIONE: SCHEMA DI COMANDO OUTPUT

Data 16/07/2024

Firma *Micro Bartoloso*

Contr./Appr.



B
022

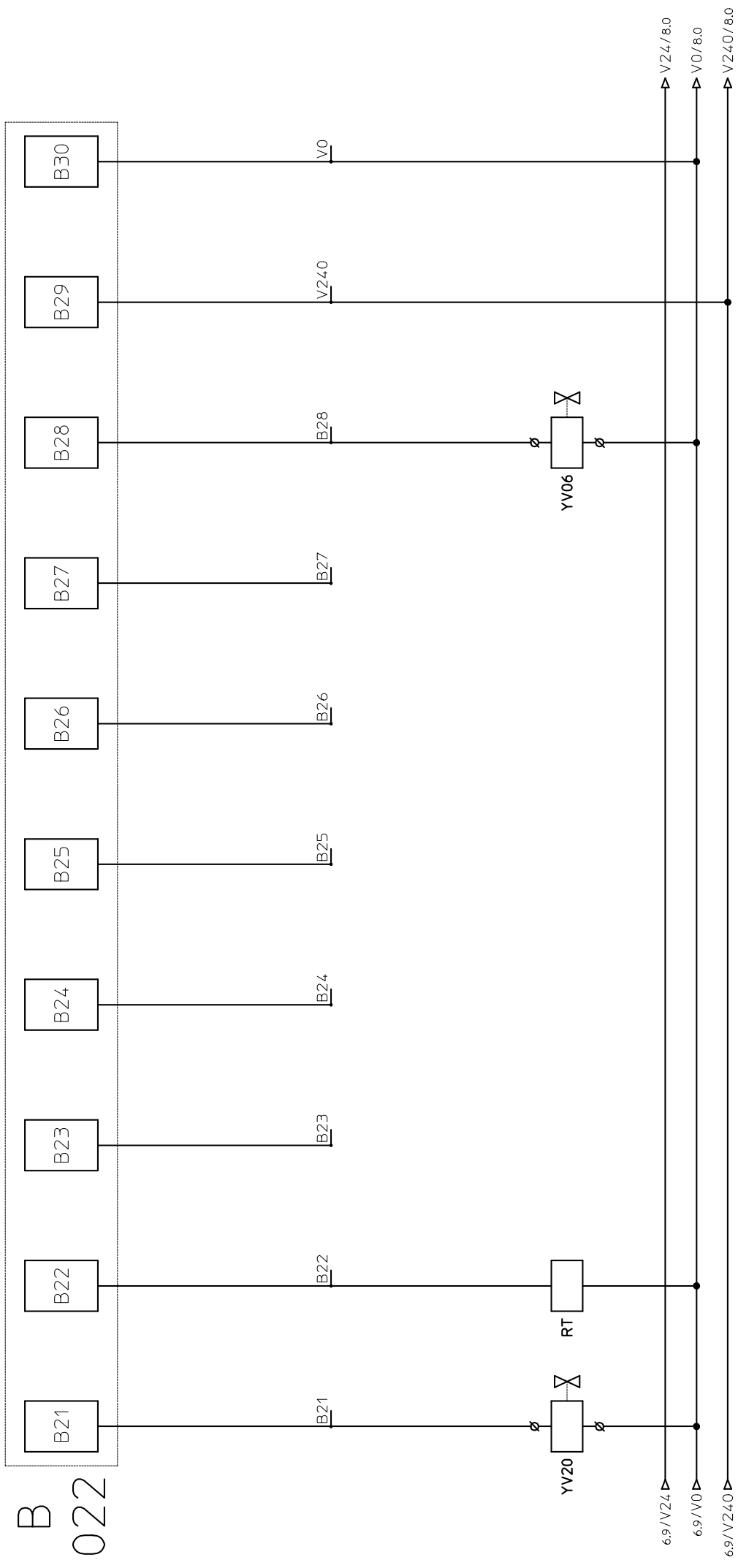

Rev./Modificato	C./Appr.	Data	Descrizione
DENOMINAZIONE: SCHEMA DI COMANDO OUTPUT			
Modello: Special 411 AG			
Macchina: AUTOMATICA			
N° Schema /			
Data 16/07/2024			Revisione
Firma <i>Micro Bartoloso</i>			Foglio
Contr./Appr.			7 di 22



B
022

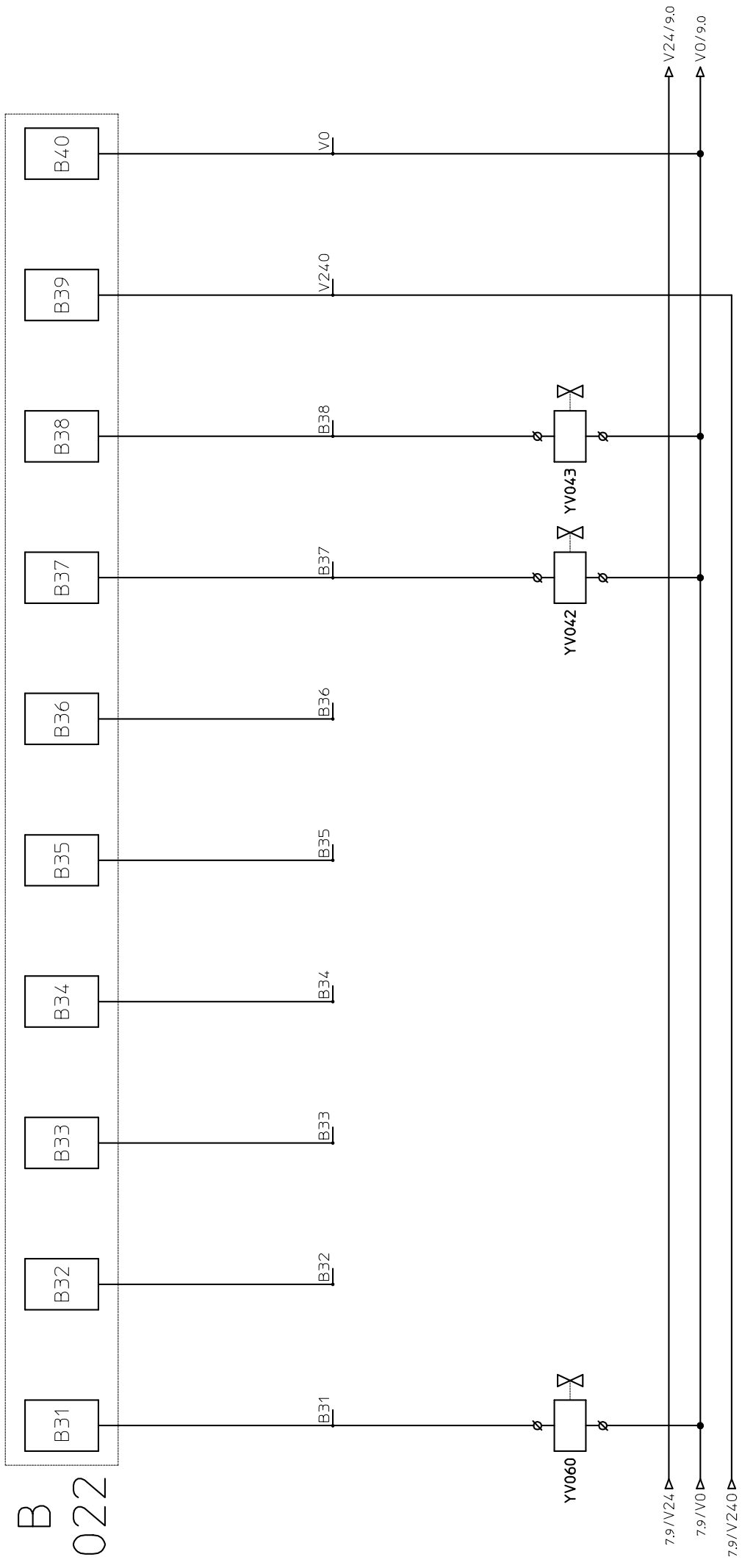

Rev.	Modificato	C./Appr.	Data	Descrizione
				Modello: Special 411 AG
				Macchina: AUTOMATICA
				N° Schema /
				Revisione
				Foglio
				8
				di
				22



Denominazione: SCHEMA DI COMANDO OUTPUT
 Data: 16/07/2024
 Firma: Mirco Bartalosa
 Contr./Appr.:

A
022

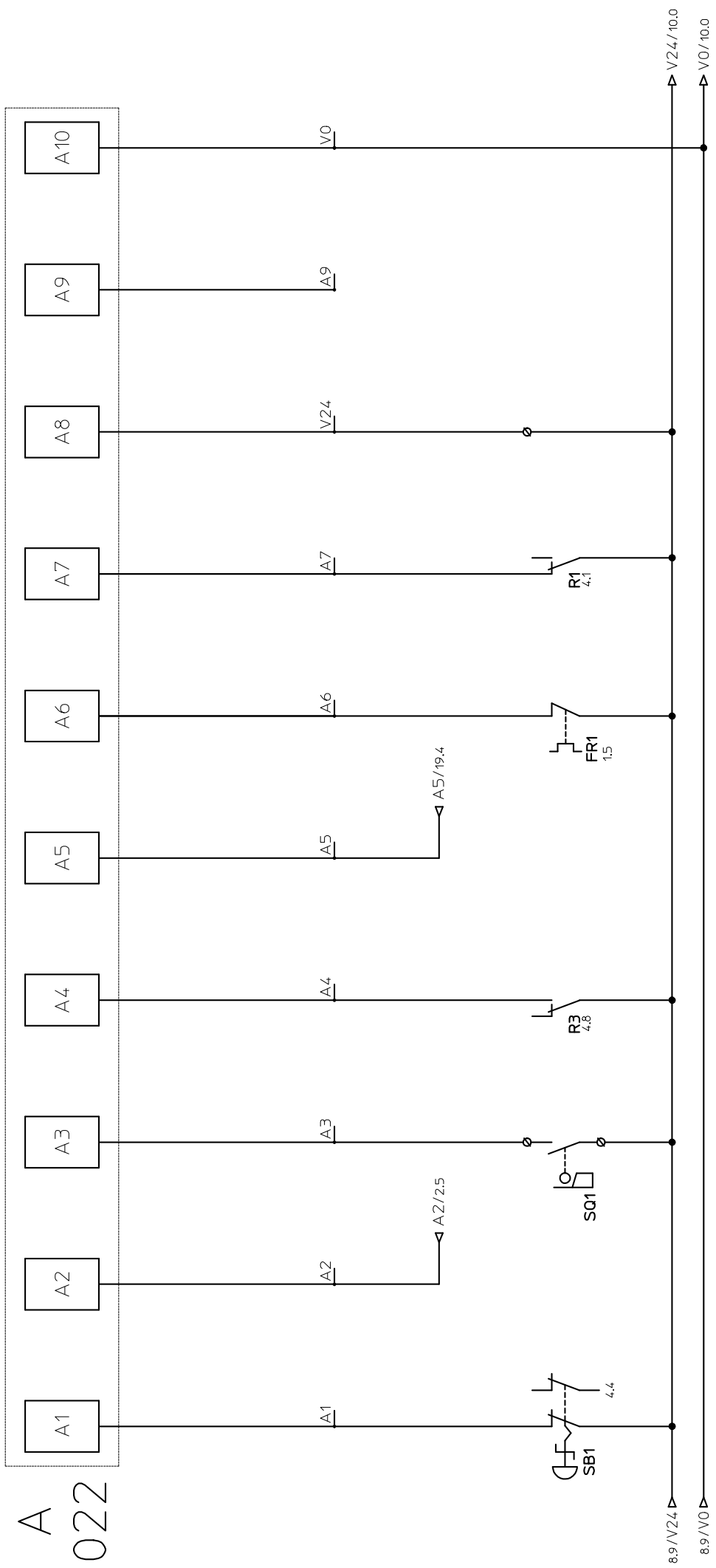

Rev./Modificato	C./Appr.	Data	Descrizione
DENOMINAZIONE: SCHEMA DI COMANDO INPUT			Modello: Special 411 AG
			Macchina: AUTOMATICA
Data 16/07/2024			N° Schema /
Firma <i>Mirco Bartoloso</i>			Revisione
Contr./Appr.			Foglio 9 di 22



0 1 2 3 4 5 6 7 8 9

A
022

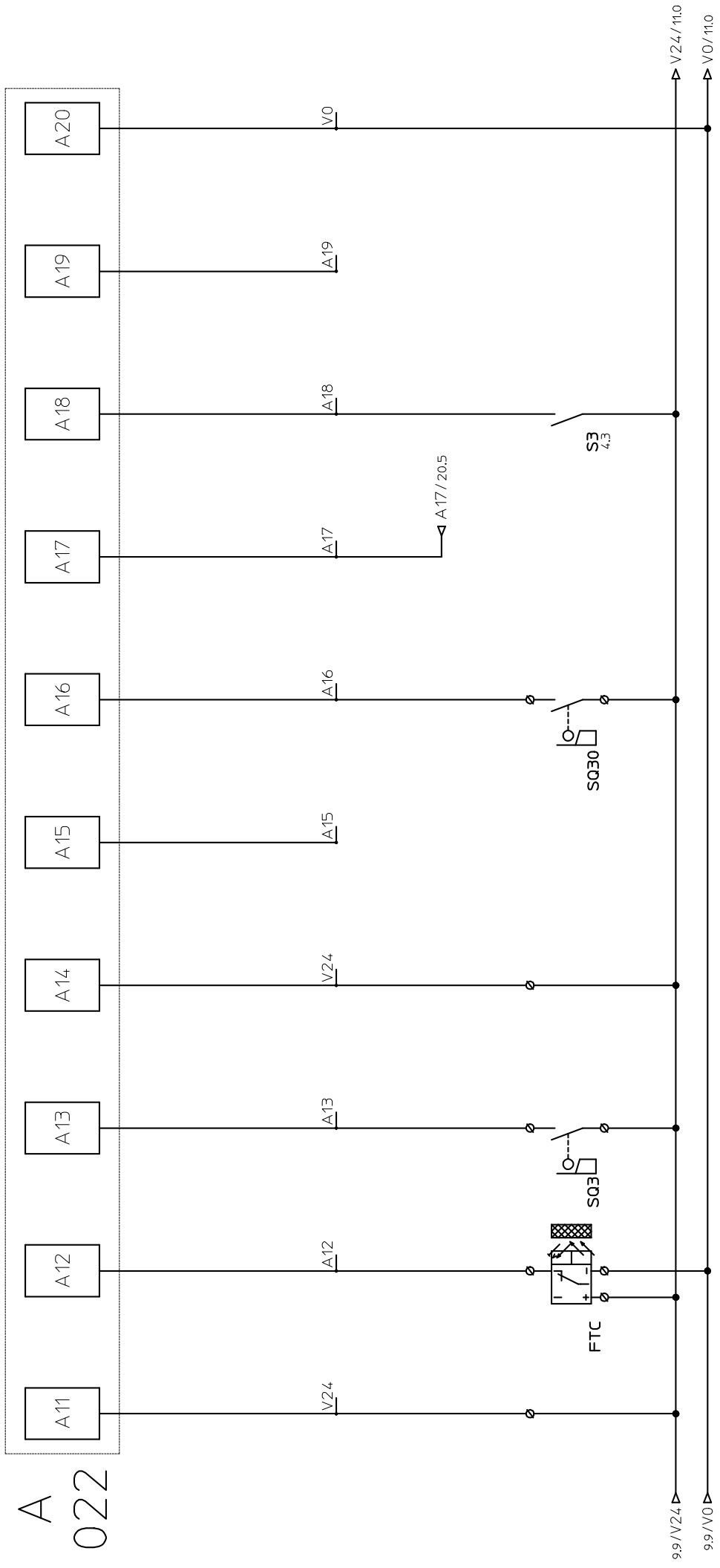

Rev./Modificato	C./Appr.	Data	Descrizione
DENOMINAZIONE: SCHEMA DI COMANDO INPUT			
Modello: Special 411 AG			
Macchina: AUTOMATICA			
N° Schema /			
Data 16/07/2024			Revisione
Firma <i>Micro Bartoloso</i>			Foglio
Contr./Appr.			di 22



B
022

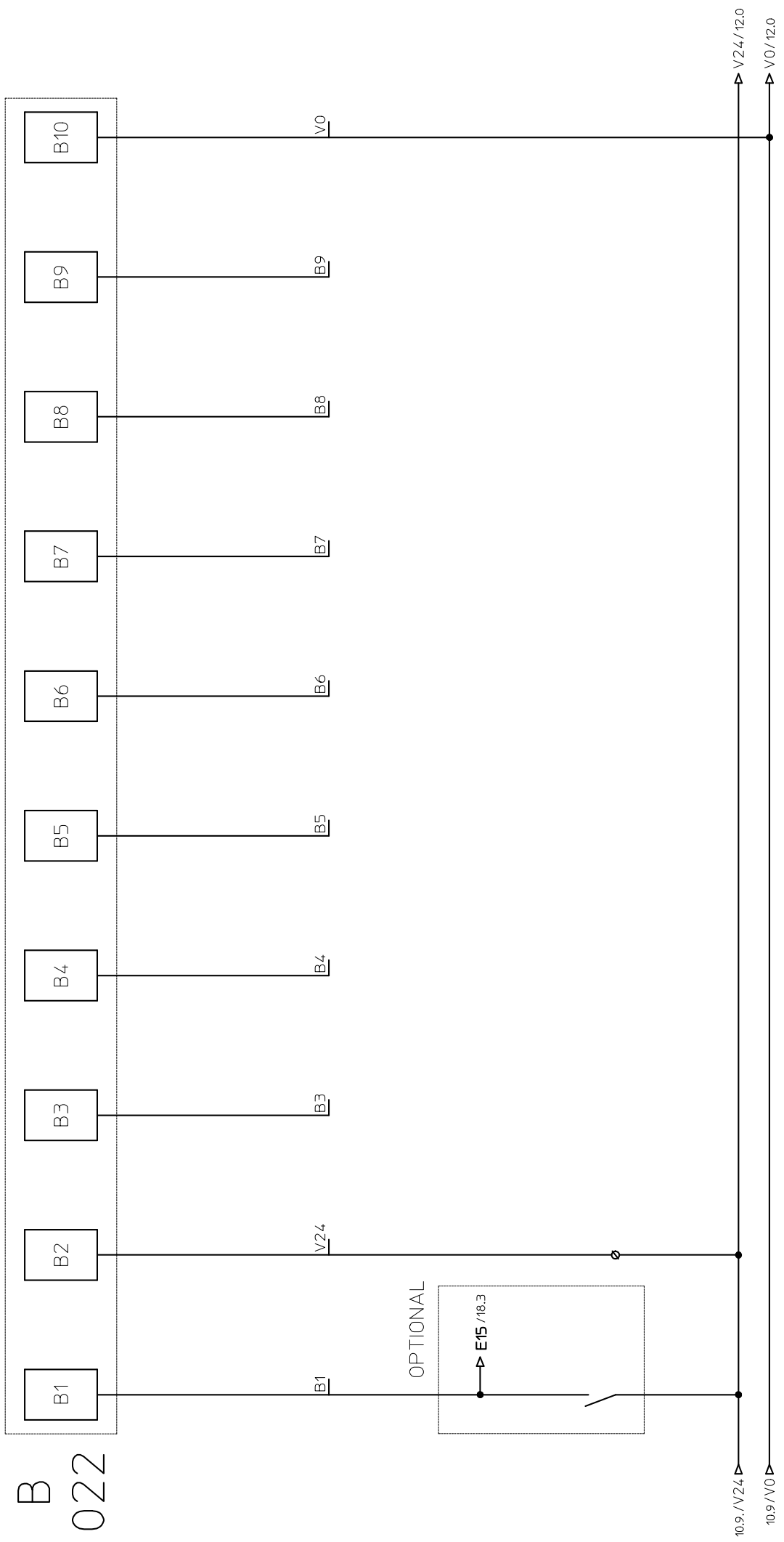

Rev./Modificato	C./Appr.	Data	Descrizione
DENOMINAZIONE: SCHEMA DI COMANDO INPUT			
Modello: Special 411 AG			
Macchina: AUTOMATICA			
N° Schema /			
Data	16/07/2024		
Firma	Micro Bartoloso		
Contr./Appr.		Revisione	Foglio
		11	22



B
022

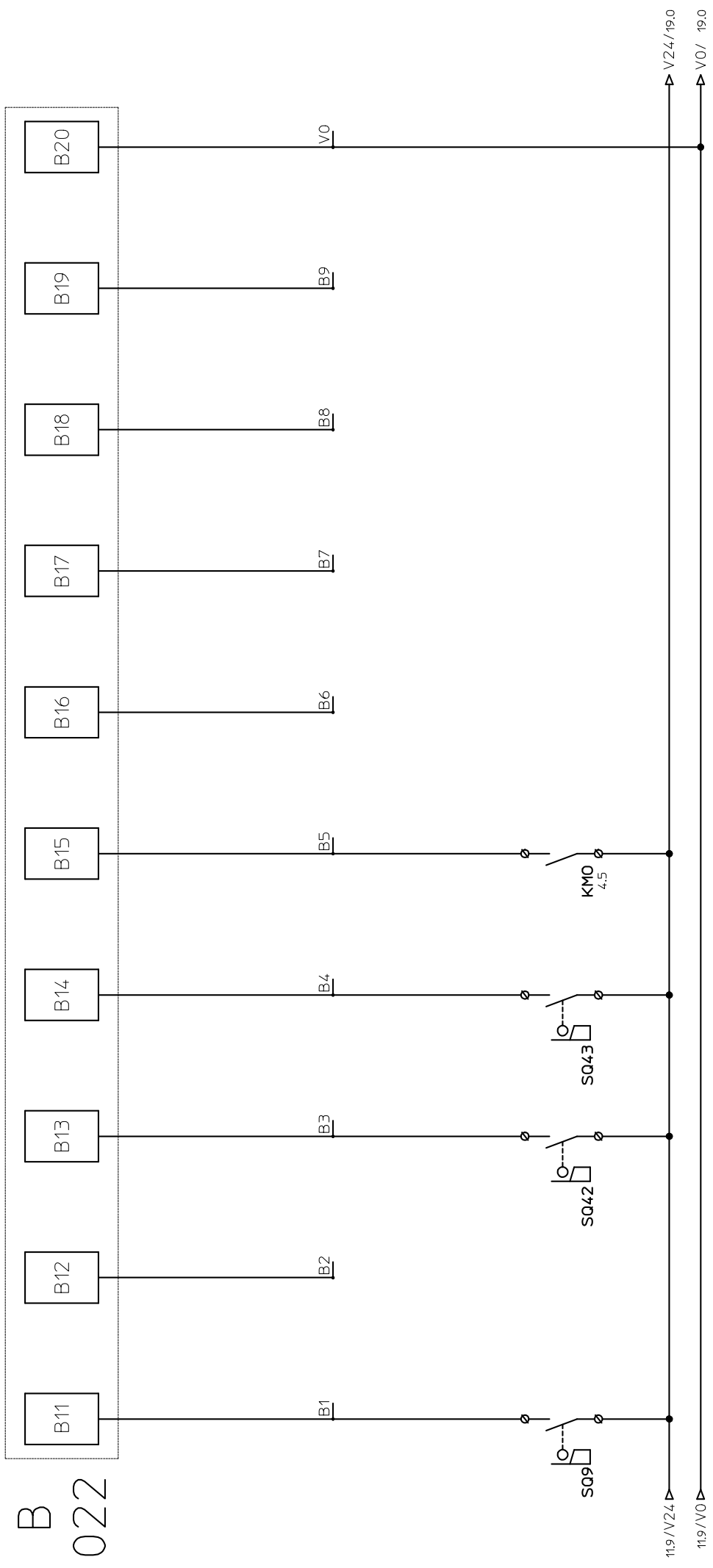

Rev.	Modificato	C./Appr.	Data	Descrizione
				Modello: Special 411 AG
				Macchina: AUTOMATICA
				N° Schema /
				Revisione
				Foglio
				12 di 22

DENOMINAZIONE: SCHEMA DI COMANDO INPUT

Data 16/07/2024

Firma *Micro Bartoloso*

Contr./Appr. Schio



C
031

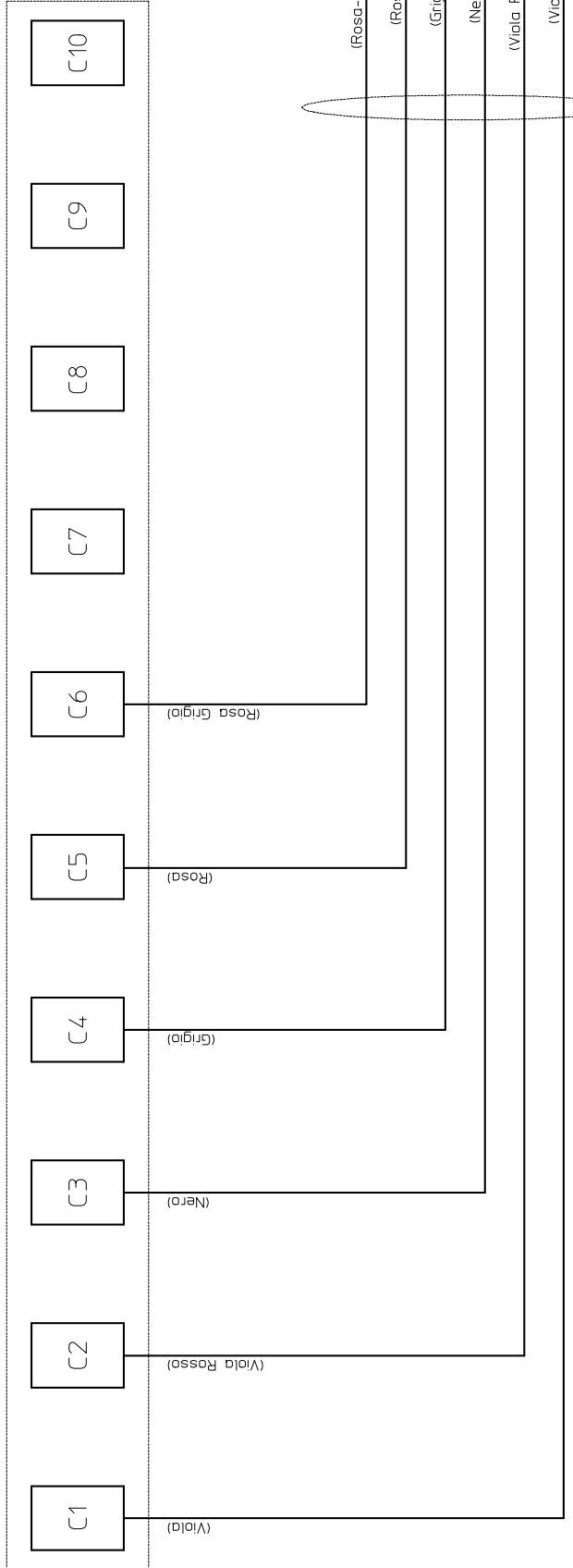

Rev./Modificato	C./Appr.	Data	Descrizione
DENOMINAZIONE: SCHEMA ENCODER CARRO			
Data	16/07/2024	Modello: Special 411 AG	
Firma	Micro Bartaloso	Macchina: AUTOMATICA	
Contr./Appr.		N° Schema /	
		Revisione	Foglio
		13	22



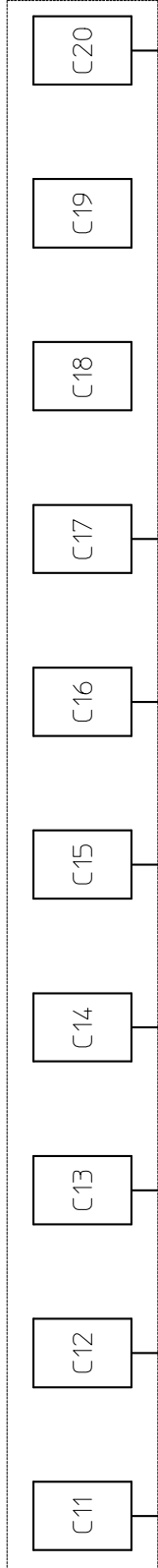

C
031

LETTORE
 ROTAZIONE
 ARCO
 SIKO

- Ø (Nero) V0
- Ø (Marrone) +5V
- Ø (Viola) 0-
- Ø (Blu) 0+
- Ø (Verde) B-
- Ø (Arancione) B+
- Ø (Giallo) A-
- Ø (Rosso) A+

13.8/PE

PE/15.0

Rev./Modificato	C./Appr.	Data	Descrizione
DENOMINAZIONE: SCHEMA ENCODER ROTAZIONE			
Modello: Saecid 411 AG			
Macchina: AUTOMATICA			
Data 16/07/2024			
N° Schema /			
Firma <i>Mirco Bartalosa</i>			Revisione
Contr./Appr.			Foglio
			14 di 22



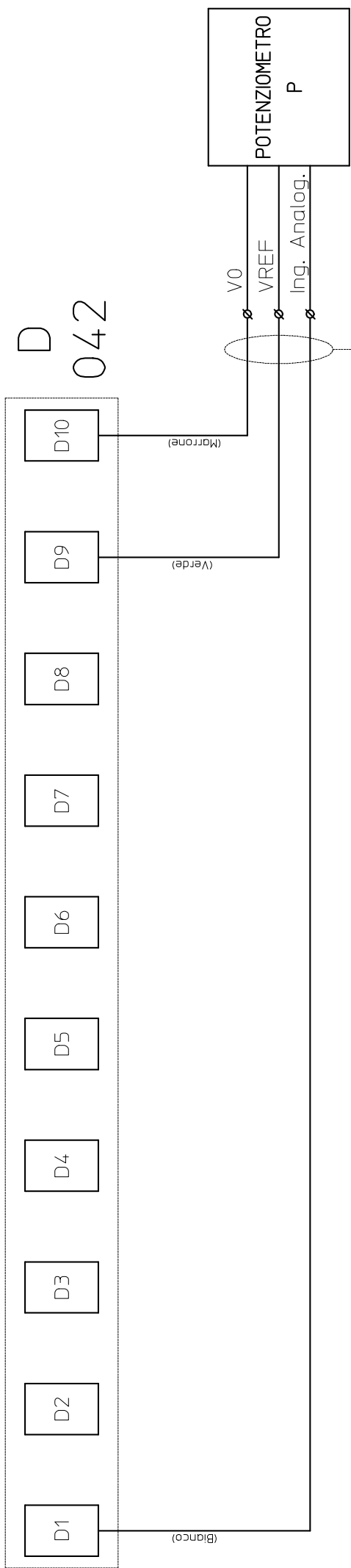

Rev./Modificato	C./Appr.	Data	Descrizione
			DENOMINAZIONE: SCHEMA POTENZIOMETRO
			Modello: Special 411 AG
			Macchina: AUTOMATICA
			N° Schema /
			Revisione Foglio
			15 di 22

Data **16/07/2024**

Firma **Micro Bartoloso**

Contr./Appr.



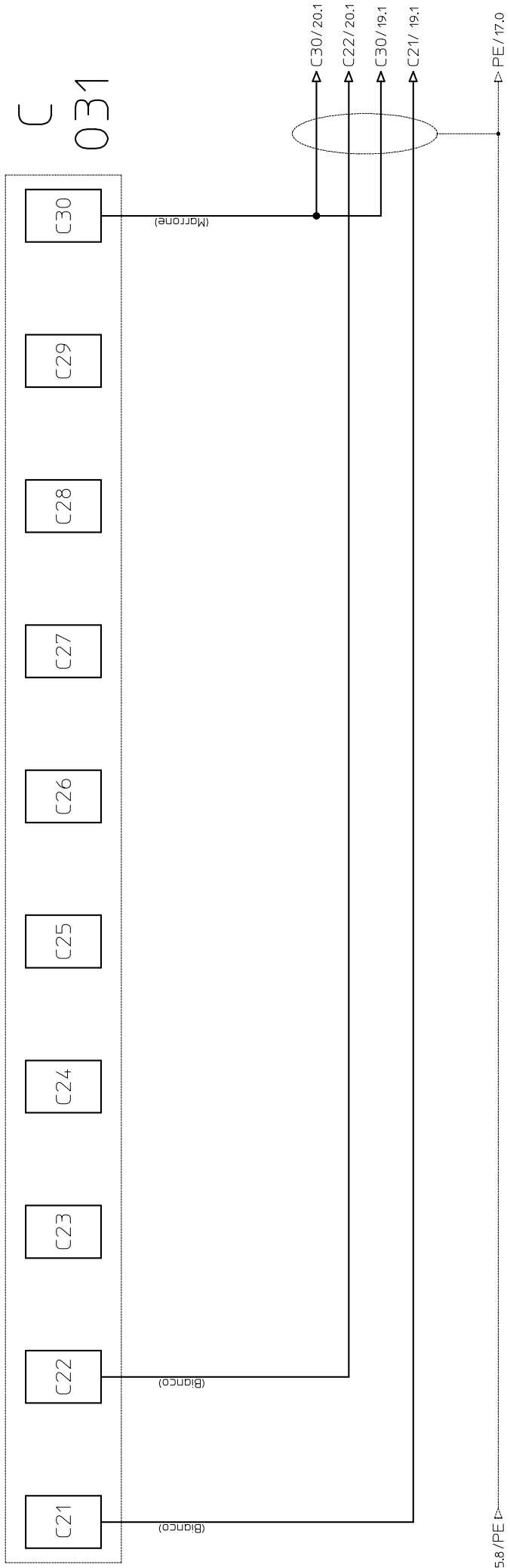

Rev./Modificato	C./Appr.	Data	Descrizione
DENOMINAZIONE: SCHEMA OUTPUT ANALOGICHE			
Modello: Special 411 AG			
Macchina: AUTOMATICA			
N° Schema /			
Data	16/07/2024		
Firma	Micro Bartoloso		
Contr./Appr.			
Revisione		16	di
Foglio			22



15.8/PE

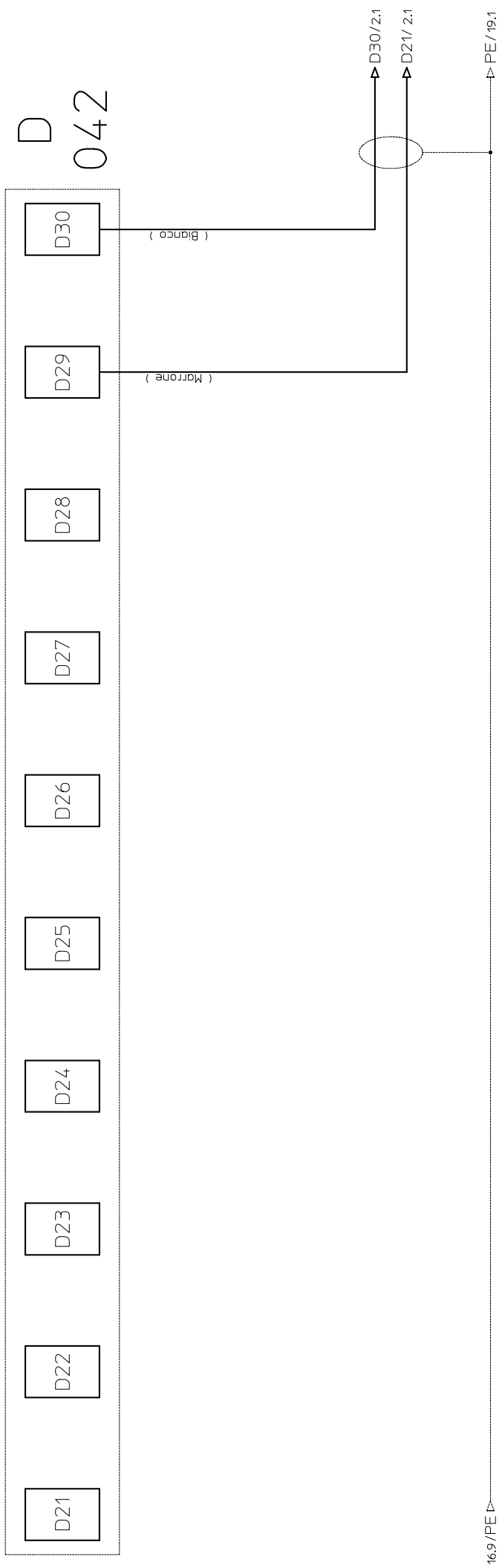

Rev./Modificato	C./Appr.	Data	Descrizione
DENOMINAZIONE: SCHEMA OUTPUT ANALOGICA			
Modello: Special 411 AG			
Macchina: AUTOMATICA			
N° Schema /			
Data	16/07/2024		
Firma	Micro Bartoloso		
Contr./Appr.		Revisione	Foglio
		17	di 22



E 031

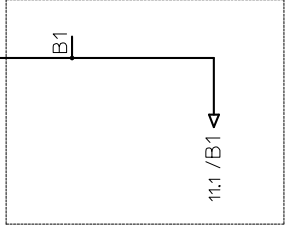
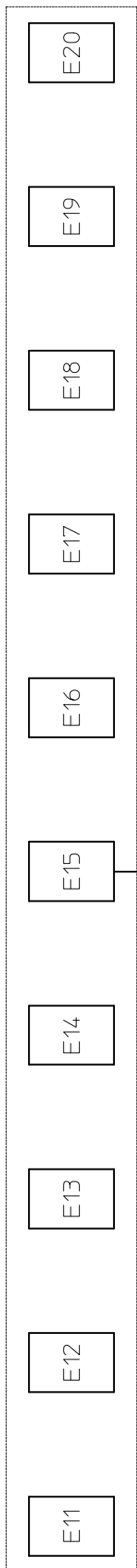

OPTIONAL

Rev./Modificato	C./Appr.	Data	Descrizione
DENOMINAZIONE: SCHEMA DI COMANDO INPUT			
Modello: Special 411 AG			
Macchina: AUTOMATICA			
N° Schema /			
Data	16/07/2024		
Firma	Micro Bartalosa		
Contr./Appr.		Revisione	Foglio
		18	22



0 1 2 3 4 5 6 7 8 9

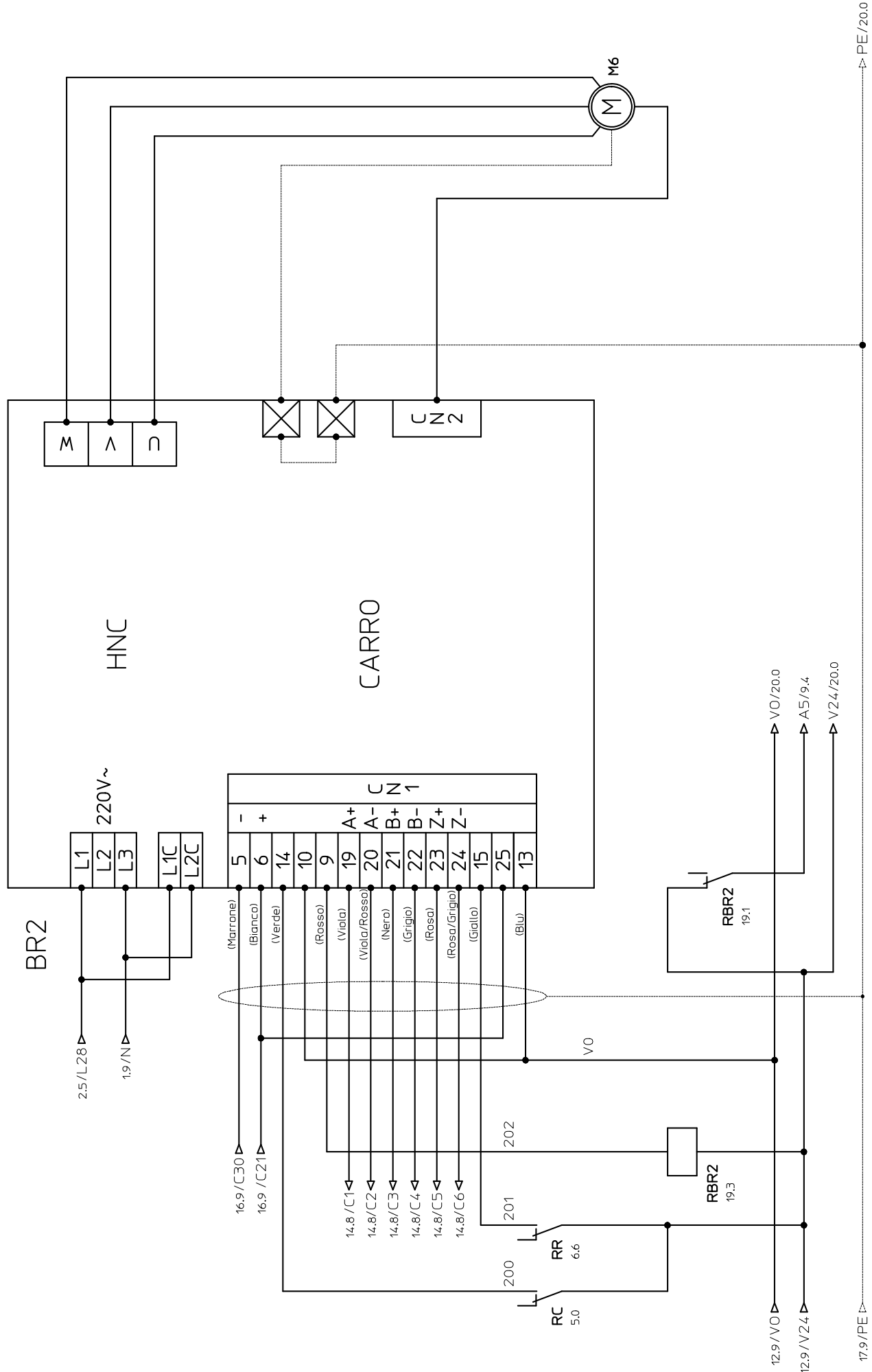

Rev./Modificato	C./Appr.	Data	Descrizione
DENOMINAZIONE: SCHEMA BRUSLESS CARRO			
Modello: Special 411 AG			
Macchina: AUTOMATICA			
N° Schema /			
Data 16/07/2024		Revisione	
Firma <i>Marco Bartoloso</i>		Foglio	
Contr./Appr.		di 22	

Rev./Modificato	C./Appr.	Data	Descrizione
DENOMINAZIONE: SCHEMA BRUSLESS CARRO			
Modello: Special 411 AG			
Macchina: AUTOMATICA			
N° Schema /			
Data 16/07/2024		Revisione	
Firma <i>Marco Bartoloso</i>		Foglio	
Contr./Appr.		di 22	

0 1 2 3 4 5 6 7 8 9

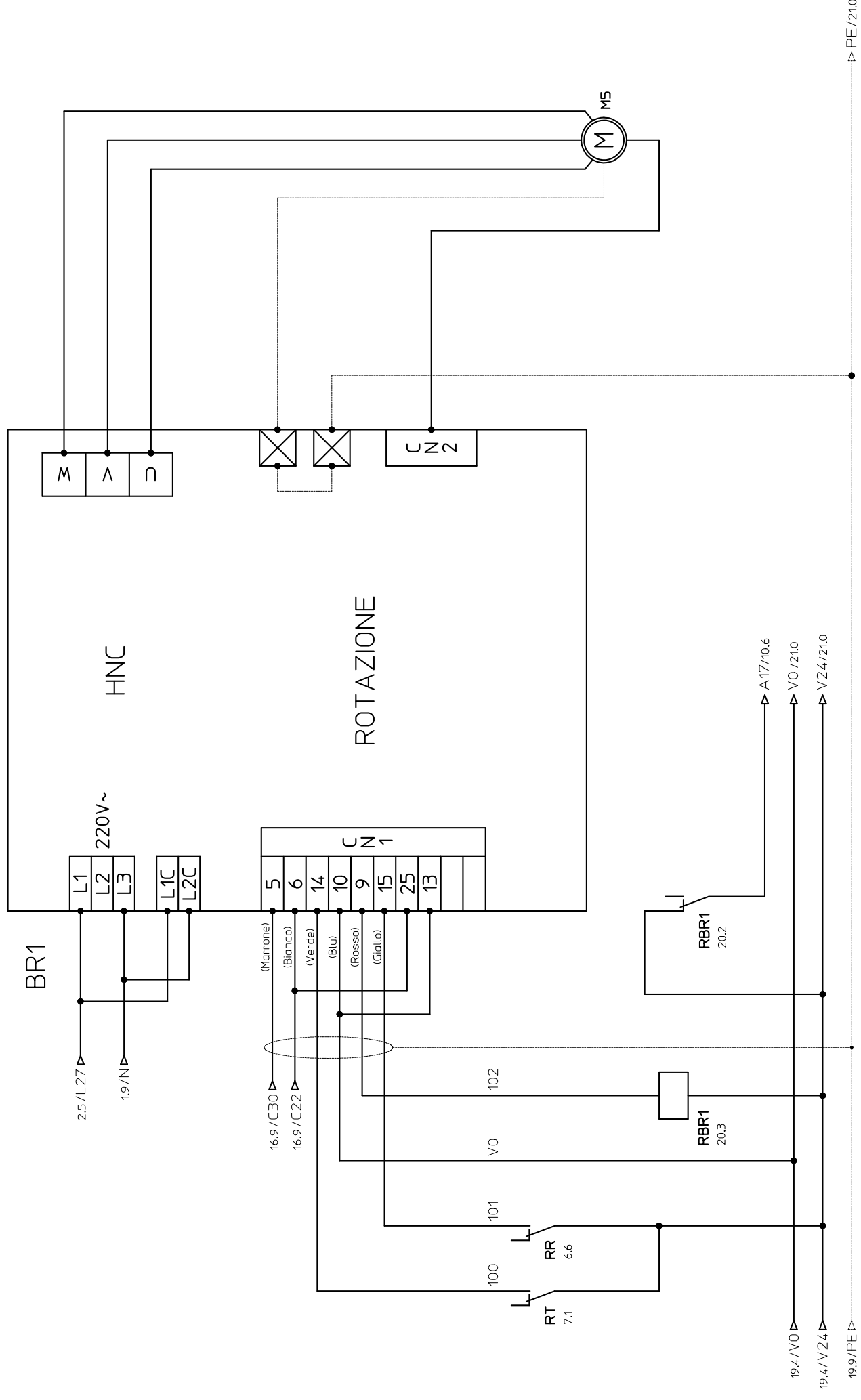

Rev./Modificato	C./Appr.	Data	Descrizione
DENOMINAZIONE: SCHEMA BRUSLESS TESTA			
Modello: Special 411 AG			
Macchina: AUTOMATICA			
N° Schema /			
Firma <i>Micro Bartoloso</i>			Revisione
Contr./Appr.			Foglio
			20
			di
			22



20.3

PE/210

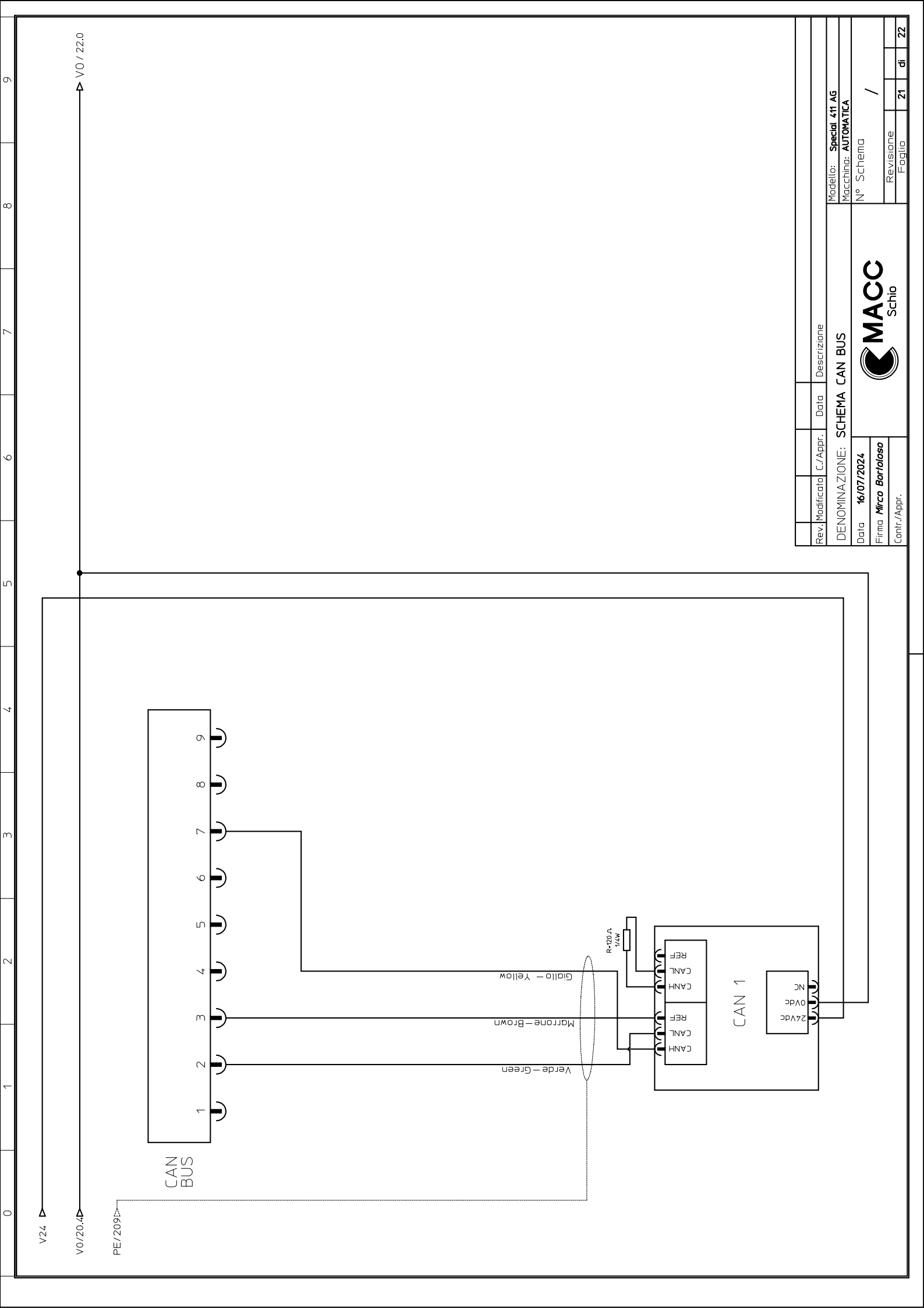

V24

V0/20.4

PE/209

CAN
BUS

CAN 1

24Vdc
0Vdc
NC

R-120 Ω
1/4W

Verde - Green

Marrone - Brown

Giallo - Yellow

V0 / 22.0

Rev./Modificato	C./Appr.	Data	Descrizione
DENOMINAZIONE: SCHEMA CAN BUS			
Data	16/07/2024	N° Schema /	
Firma	Micro Bartoloso	Revisione	
Contr./Appr.	Schio	Foglio	21
		di	22



Modello: **Special 411 AG**

Macchina: **AUTOMATICA**

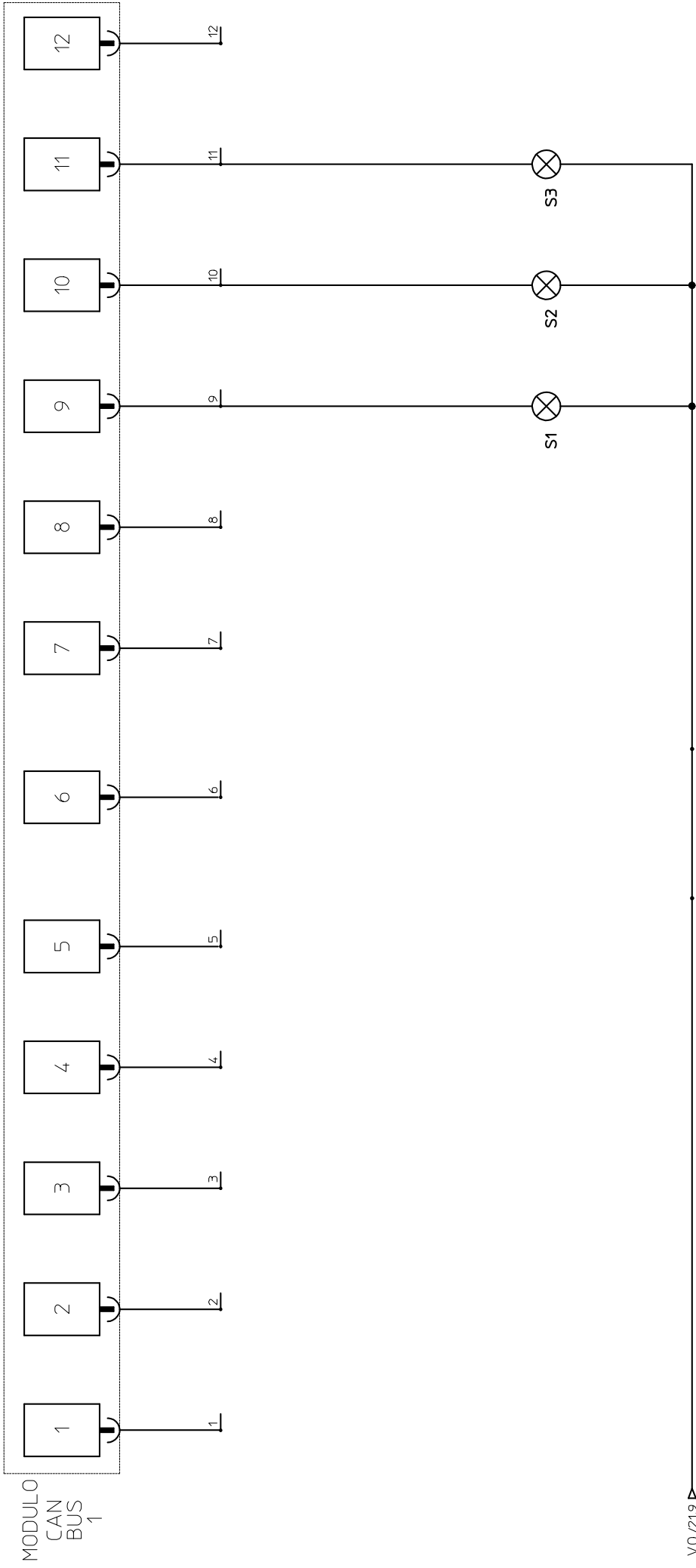

Rev./Modificato	C./Appr.	Data	Descrizione
DENOMINAZIONE: SCHEMA CAN BUS I / 0			
Modello: Special 411 AG			
Macchina: AUTOMATICA			
N° Schema /			
Data	16/07/2024		
Firma	Micro Bartoloso		
Contr./Appr.		Revisione	Foglio
		22	22
		di	22



CONTROLLATO IL:	18/11/2024
DA:	
REV.:	0