

*Powering Business Worldwide*

# Table of Contents

## M Series Variable Displacement Piston Pumps

<b>Introduction</b> .....	3
<b>Hydraulic System Design Calculations</b> .....	4
<b>Model Code Selection</b> .....	5
<b>Model Code Options</b> .....	6
<b>Specifications and Performance</b> .....	8
<b>Control Options</b> .....	11
<b>Performance – Industrial</b>	
PVM018 .....	15
PVM020 .....	20
PVM045 .....	25
PVM050 .....	30
PVM057 .....	35
PVM063 .....	40
PVM074 .....	45
PVM081 .....	50
PVM098 .....	55
PVM106 .....	60
PVM131 .....	65
PVM141 .....	70
<b>Dimensions</b>	
PVM018/020 .....	75
PVM045/050 .....	82
PVM057/063 .....	89
PVM074/081 .....	94
PVM098/106 .....	98
PVM131/141 .....	102
<b>Mounting Flange Options</b> .....	107
<b>Shaft Options</b> .....	108
<b>Input Shaft Selection Data</b> .....	111
<b>Port Options</b> .....	112
<b>Operating Requirements and Recommendations</b> .....	114
<b>Installation and Start-up</b> .....	115

# Introduction

Eaton M Series pumps are open circuit, axial piston designs. A variety of control options allows the pumps to perform most efficiently in a specific application. Efficiency of the pump controls allows down-sizing of system cooling needs, saving up front cost in the machine. Alternatively, cooling capacity could be kept the same and the flow capability of the system increased, thus improving performance and customer satisfaction.

The M Series also contains a strong proven rotating group allowing the pumps to handle pressures to 280 bar (4000 psi) continuous and 320 bar (4600 psi) intermittent – with less maintenance cost. High-load bearings and a stiff drive shaft help provide a pump life of 8000 hours at rated industrial conditions, reducing operating costs and extending operating life.

M Series pumps feature a saddle-type yoke with steel-backed polymer bearings. The stiff yoke reduces deflection and allows even loading of bearings, improving life. A single control piston reduces loading on the yoke, resulting in reduced pump size which allows installation in tighter locations.

M Series pumps operate at a level of quietness that exceeds the requirements of today's demanding work conditions. The pumps feature a unique three-piece envelope (flange, housing and valve block) specifically created for low fluid-borne and structure-borne noise levels. Another pump feature – a bimetal timing plate – improves pump filling characteristics which, in turn, reduce fluid-borne noise and extend pump life.

M Series pumps reduce, or in some cases remove, the need for damping barriers between the noise source and the operator. This saves money on the installed cost of the system while improving customer comfort.

An adjustable maximum stop provides a means of tuning flow to your system, while gauge ports allow monitoring of inlet and outlet conditions. These standard features reduce system complexity and cost.

Mounting flanges are offered in SAE and ISO configurations, and ports are offered in SAE, ISO, and

BSPP in both tube and flange versions. This provides a wide variety of installation opportunities for global machine design.

Side- or end-ported models are available to facilitate plumbing and help fit the pump to your machine space needs. Multiple drain ports allow many mounting orientations, reducing installed costs.

M Series pumps are capable of operating with many types of hydraulic fluids used in industrial systems. High-water-content and phosphate ester fluids can be accommodated, in addition to the typical petroleum based and synthetic fluids.

## Typical Applications

- Mining machinery
- Injection molding machines
- Metal forming machines
- Oil and Gas Equipment
- Conveyor lines
- Primary metals
- Metal cutting equipment

## Features and Benefits

- Long pump life
- Quiet pump operation
- Inlet and outlet gauge ports and adjustable maximum displacement stops – standards
- Astonishingly low 4% pressure ripple
- Low installed and operating costs
- Reduced maintenance
- Flexibility in machine design
- Design promotes leak-free system

# Hydraulic System Design Calculations

## Basic Formulas

### Output Flow (Q)

$$\text{lpm} = \frac{\text{cm}^3/\text{r} \times \text{rpm}}{1000} \quad \text{gpm} = \frac{\text{in}^3/\text{r} \times \text{rpm}}{231}$$

### Input Power (P)

$$\text{kW} = \frac{\text{l/min} \times \text{bar}}{600} \quad \text{hp} = \frac{\text{gpm} \times \text{psi}}{1714}$$

### Shaft Torque (M)

$$\text{N-m} = \frac{\text{bar} \times \text{cm}^3/\text{r}}{62.8} \quad \text{lb-in} = \frac{\text{psi} \times \text{in}^3/\text{r}}{6.28}$$

### Shaft Speed (n)

$$\text{rpm} = \frac{1000 \times \text{l/min}}{\text{cm}^3/\text{r}} \quad \text{RPM} = \frac{231 \times \text{gpm}}{\text{in}^3/\text{r}}$$

### Output Power (P)

$$\text{kW} = \frac{\text{N-m} \times \text{RPM}}{9549} \quad \text{hp} = \frac{\text{lb-in} \times \text{rpm}}{63,025}$$

### Volumetric Displacement

$$\text{cm}^3/\text{r} = \frac{\text{lpm} \times 1000}{\text{rpm}} \quad \frac{\text{gpm} \times 231}{\text{rpm}}$$

## Basic Formulas

bar = 10 Newtons/cm<sup>2</sup>

gpm = gallons per minute

hp = horsepower

lb-in = pound inch

lb-ft = pound feet

kW = kilowatt

kgf = kilograms force

l/min = liters per minute

N-m = Newton meters

psi = pounds per square inch

rpm = revolutions per minute

## Efficiencies

$$\text{Volumetric } N_v = \frac{\text{gpm actual}}{\text{gpm theoretical}}$$

$$\text{Mechanical } N_m = \frac{\text{lb-in actual}}{\text{lb-in theoretical}}$$

$$\text{Total } N_t = N_v \times N_m$$

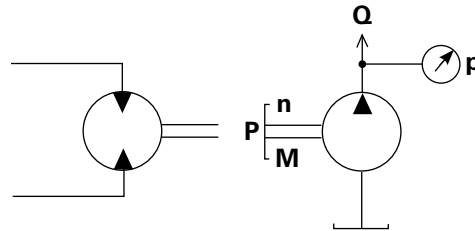

## Commonly Used Conversions

To Convert	Into	Multiply by
bar	psi	14.5
cm <sup>3</sup>	in <sup>3</sup>	0.06102
°C	°F	(°C x 1.8) + 32
gallons (US)	liters	3.785
kg	lbs	2.205
kgf/cm <sup>2</sup>	psi	14.2
kW	hp	1.341
liters	US Gallons	0.2642
mm	inches	0.03937
N-m	lb-in	8.85
N-m	lb-ft	0.7375
°F	°C	(°F-32)/1.8
hp	kW	0.7457
inch	mm	2.54
in <sup>3</sup>	cm <sup>3</sup>	16.39
lb-in	N-m	0.113
lb-ft	N-m	1.356
lbs	kg	0.4535
psi	bar	0.06896
psi	kgf/cm <sup>2</sup>	.070307

**Note:** Performance charts can be found on subsequent pages.

# Model Code Selection

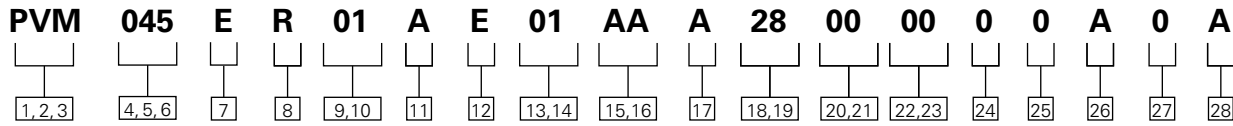

**1,2,3 Product Series**  
**PVM** – M Series Variable Piston Pump

**4,5,6 Displacement**  
 Twelve displacements available 230 bar and 280 bar continuous ratings

**7 Valve Plate**  
**E** – Industrial Equipment Speeds

**8 Input Rotation**  
**R** – Clockwise (Righthand)  
**L\*** – Counter-clockwise (Lefthand)

**9,10 Input Shaft**  
 Standard SAE and ISO splined versions (Other configurations optional)

**11 Mounting Flange**  
 Thirteen options in SAE and ISO mounts

**12 Main Port Location**  
**E\*\*** – End Ported  
**S\*\*\*\*** – Side Ported

**13,14 Main Port Type**  
 SAE & ISO tube ports and 4-bolt flange (Other configurations optional)

**15,16 Pump Special Features**  
**00** – None  
**AA** – Adjustable Maximum Displacement Stop and single shaft (standard)  
**AB** – Double Shaft Seal, Two Way

**17 Control**  
**0** – None  
**A** – Pressure Compensator  
**B** – Pressure and Flow Compensator with Bleed Orifice  
**C** – Pressure and Flow Compensator with Plugged Orifice  
**E** – Industrial Control (57cc through 141 cc only)

**18,19 Pressure Compensator Setting**  
**00** – None  
**07** – 70 bar (Adjustable between 40 bar and 130 bar)  
**23** – 230 bar (Adjustable between 130 bar and 320 bar)  
**28** – 280 bar (Adjustable between 130 bar and 320 bar)

**20,21 Flow Compensator Setting**  
**00** – None  
**11** – 11 bar setting  
**20** – 20-20 bar setting  
**24** – 24-24 bar setting

**22,23 Torque Limiter Setting**  
**00** – None (Not available on M Series)

**24 Compensator Special Features**  
**0** – None

**25 Auxiliary Mounting Pad**  
**0\*\*\*** – None  
 (Auxiliary mounting available on all frame sizes)

**26 Paint**  
**0** – No Paint  
**A** – Standard Blue Paint

**27 Customer Identification**  
**0** – None (Contact Eaton for Options)

**28 Design Code**  
**A** – A (Initial Release)

\* Not available on 074, 081, 098 and 106 End Port

\*\* Not available on 074, 081, 098 and 106 LH

\*\*\* Through drive not available on the LH

\*\*\*\* Not available on 018

# Model Code Options

## 4,5,6 Maximum Geometric Displacement

Displacement Code	018	020	045	050	057	063	074	081	098	106	131	141
cm <sup>3</sup> /r	18,0	21,1	45,1	50,0	57,4	63,1	73,7	81,0	98,3	106,5	131,1	141,0
in <sup>3</sup> /r	1.1	1.29	2.75	3.05	3.50	3.85	4.50	4.94	6.00	6.50	8.00	8.60

## 9,10 Shaft-End Type at Electric Motor End

Description	Shaft Code					
	PVM018/020	PVM045/050	PVM057/063	PVM074/081	PVM098/106	PVM131/141
SAE, SAE A, Straight Keyed	01	–	–	–	–	–
SAE, SAE 19-1, Straight Keyed	02	–	–	–	–	–
SAE, SAE A, 9T Spline	03	–	–	–	–	–
SAE, SAE A, 11T Spline	04	–	–	–	–	–
SAE, SAE B, Straight Keyed	05	05	–	–	–	–
SAE, SAE B-B, Straight Keyed	06	06	06	–	–	–
SAE, SAE B, 13T Spline	07	07	07	–	–	–
SAE, SAE B-B, 15T Spline	08	08	08	–	–	–
SAE, SAE C, Straight Keyed	–	–	09	09	09	09
SAE, SAE C-C, Straight Keyed	–	–	–	10	10	10
SAE, SAE C, 14T Spline	–	–	11	11	11	11
SAE, SAE C-C, 17T Spline	–	–	–	12	12	12
SAE, SAE D, Straight Keyed	–	–	–	–	–	13
SAE, SAE D, 13T Spline	–	–	–	–	–	14
ISO E20N, Straight Keyed	15	–	–	–	–	–
ISO E25N, Straight Keyed, Short Spigot	16	–	–	–	–	–
ISO E25N, Straight Keyed	17	17	17	–	–	–
ISO E32N, Straight Keyed, Short Spigot	–	–	18	18	18	18
ISO E40N, Straight Keyed, Short Spigot	–	–	–	19	19	19

## 11 Mounting Flange Specifications

Code	Description	PVM018/020	PVM045/050	PVM057/063	PVM074/081	PVM098/106	PVM131/141
A	SAE A, 2-bolt	•	◦	◦	◦	◦	◦
B	ISO 80A2HW	•	◦	◦	◦	◦	◦
C	SAE B, 2-bolt	•	•	•	◦	◦	◦
D	ISO 100A2HW	•	•	•	◦	◦	◦
E	SAE C, 2-bolt	◦	◦	•	•	•	•
F	ISO 125-A2HW	◦	◦	•	•	•	•
G	SAE C, 4-bolt	◦	◦	•	•	•	•
H	ISO 125B4HW	◦	◦	•	•	•	•
J	SAE D, 4-bolt	◦	◦	◦	◦	◦	•
K	ISO 160B4HW	◦	◦	◦	◦	◦	•

• = Available  
◦ = Not Available

# Model Code Options

## 13,14 Main Port Options

Code	Description	Inlet		PVM018/020	PVM045/050	PVM057/063	PVM074/081	PVM098/106	PVM131/141
		Outlet							
01	SAE J1926 Tube Ports	Inlet		-20	-24	-24 (End ports only)	-	-	-
		Outlet		-12	-16	-16 (End ports only)	-	-	-
02	SAE J518 Flange Ports	Inlet		1.25 inch	2.0 inch	2.0 inch	2.0 inch	2.5 inch	2.5 inch
		Outlet		0.75 inch	1.0 inch	1.0 inch	1.0 inch	1.0 inch	1.25 inch*
03	ISO 6149-1 Tube Ports	Inlet		M42	M48	M48 (End ports only)	-	-	-
		Outlet		M27	M33	M33 (End ports only)	-	-	-
04	ISO 6162 Flange Ports	Inlet		32mm	51mm	51mm	51mm	64mm	64mm
		Outlet		19mm	25mm	25mm	25mm	25mm	32mm*
05	British Standard Parallel Pipe – Tube Ports	Inlet		G 1-1/4	G 1-1/2	-	-	-	-
		Outlet		G 3/4	G 1	-	-	-	-

\*SAE Code 62, high pressure series, or ISO 400 bar. Other flange ports are SAE Code 61, standard pressure series, or ISO 25-350 bar.

## 25 Thru-Drive Options

Code	Description	PVM018/020	PVM045/050	PVM057/063	PVM074/081*	PVM098/106	PVM131/141
O	Single pump, non-thru-drive	•	•	•	•	•	•
A	SAE A, 2-bolt, 9T spline	•	•	•	•	•	•
B	SAE A, 2-bolt, 11T spline	•	•	◦	•	•	•
C	SAE B, 2-1/4-bolt, 13T spline	◦	•	•	•	•	•
D	SAE B-B, 2-1/4-bolt, 15T spline	◦	•	•	•	•	•
E	SAE C, 2-1/4-bolt, 14T spline	◦	◦	•	•	•	•
F	SAE C-C, 2-1/4-bolt, 17T spline	◦	◦	◦	•	•	•
G	ISO 80-A2HW, 9T SAE spline	•	•	•	•	•	•
H	ISO 80-A2HW, 11T SAE spline	•	•	◦	•	•	•
J	ISO 100-A2/B4HW, 13T SAE spline	◦	•	•	•	•	•
K	ISO 100-A2/B4HW, 15T SAE spline	◦	◦	•	•	•	•
L	ISO 125-A2/B4HW, 14T SAE spline	◦	◦	•	•	•	•
M	ISO 125-A2/B4HW, 17T SAE spline	◦	◦	◦	•	•	•

• = Available

◦ = Not Available

\* Not available on the 074/081 LH

# Specifications and Performance

## Industrial

**Displacement, Pressure and Flow Ratings** At 50°C (120°F), SAE 10W oil, 1 bar absolute (0 psig) inlet

Model Series	Maximum Geometric Displacement cm <sup>3</sup> /r (in <sup>3</sup> /r)	Maximum Pressure bar (psi)			Maximum Flow at 280 bar (4000 psi)* l/min (USgpm) – Average measured flow rate			
		Continuous	Intermittent*	Peak**	@1800 r/min	@1500 r/min	@1200 r/min	@1000 r/min
PVM018	18 (1.1)	280 (4000)	320 (4600)	350 (5000)	31 (8.2)	26 (7)	21 (5.5)	17 (4.5)
PVM020	21,1 (1.29)	230 (3300)	250 (3600)	280 (4000)	35 (9)	29 (8)	23 (6)	19 (5)
PVM045	45,1 (2.75)	280 (4000)	320 (4600)	350 (5000)	76 (20)	65 (17)	49 (13)	42 (11)
PVM050	50,0 (3.05)	230 (3300)	250 (3600)	280 (4000)	87 (23)	75 (20)	62 (16)	49 (13)
PVM057	57,4 (3.50)	280 (4000)	320 (4600)	350 (5000)	102 (27)	85 (22.4)	66 (17.4)	54 (14.3)
PVM063	63,1 (3.85)	230 (3300)	250 (3600)	280 (4000)	111 (29)	93 (24)	74 (19)	60 (16)
PVM074	73,7 (4.50)	280 (4000)	320 (4600)	350 (5000)	127 (33.5)	106 (28)	86 (22.7)	70 (18.5)
PVM081	81,0 (4.94)	230 (3300)	250 (3600)	280 (4000)	139 (37)	116 (31)	93 (25)	76 (20)
PVM098	98,3 (6.00)	280 (4000)	320 (4600)	350 (5000)	170 (45)	141 (37)	112 (29.6)	92 (24.3)
PVM106	106,5 (6.50)	230 (3300)	250 (3600)	280 (4000)	187 (49)	155 (41)	123 (32)	102 (27)
PVM131	131,1 (8.00)	280 (4000)	320 (4600)	350 (5000)	215 (57)	178 (47)	141 (37)	118 (31)
PVM141	141,0 (8.60)	230 (3300)	250 (3600)	280 (4000)	238 (63)	199 (53)	158 (42)	131 (35)

\*Less than 10% of duty cycle.

\*\*Momentary system pressure spikes only.

**Speed, Input Power and Torque Ratings** At 50°C (120°F), SAE 10W oil, 1 bar absolute (0 psig) inlet

Model Series	Maximum Operating Speed r/min	Maximum Input Power at 280 bar (4000 psi) kw (hp)*@88% M.E.				Maximum Torque at 280 bar (4000 psi)* Nm (lb-ft)	Approximate Weight kg (lb)
		@1800 r/min	@1500 r/min	@1200 r/min	@1000 r/min		
PVM018	1800	16 (22)	13 (18)	11 (15)	9 (12)	84 (62)	15 (33)
PVM020	1800	14 (18)	11 (15)	9 (12)	8 (10)	73 (54)	15 (33)
PVM045	1800	41 (55)	34 (46)	27 (37)	23 (31)	221 (163)	24 (52)
PVM050	1800	35 (47)	30 (40)	28 (38)	23 (31)	190 (140)	24 (52)
PVM057	1800	52 (70)	44 (59)	36 (49)	29 (39)	272 (201)	36 (79)
PVM063	1800	42 (57)	36 (48)	29 (39)	24 (32)	228 (168)	36 (79)
PVM074	1800	63 (84)	52 (70)	42 (56)	35 (47)	334 (246)	45 (99)
PVM081	1800	56 (75)	46 (62)	35 (47)	28 (37)	286 (211)	45 (99)
PVM098	1800	88 (118)	72 (97)	58 (78)	48 (64)	464 (342)	55 (121)
PVM106	1800	72 (97)	60 (80)	48 (64)	40 (54)	383 (282)	55 (121)
PVM131	1800	113 (152)	94 (126)	75 (101)	63 (85)	596 (440)	66 (145)
PVM141	1800	94 (126)	79 (106)	63 (85)	53 (71)	497 (367)	66 (145)

### Standard Response Times\*

Model Series	On Stroke (msec)	Off Stroke (msec)
PVM018	30	25
PVM020	39	26
PVM045	140	40
PVM050	140	40
PVM057	65	20
PVM063	85	20

\* 3300 psi on overbore pumps

### Standard Response Times\*

Model Series	On Stroke (msec)	Off Stroke (msec)
PVM074	85	30
PVM081	85	30
PVM098	65	25
PVM106	72	29
PVM131	135	30
PVM141	100	30

\*Values with pressure compensator control.



# Specifications and Performance

## Mobile

**Displacement, Pressure and Flow Ratings** At 93°C (200°F), SAE 10W oil, 1 bar absolute (0 psig) inlet

Model Series	Geometric Displacement cm <sup>3</sup> /r (in <sup>3</sup> /r)	Maximum Pressure bar (psi)			Maximum Flow at 280 bar (4000 psi)	
		Continuous	Intermittent*	Peak**	Flange Ports l/min (USgpm) @ 1 bar inlet	Tube Ports l/min (USgpm) @ 1 bar inlet
PVM018	18,0 (1.10)	280 (4000)	320 (4600)	350 (5000)	46 (12) @ 2800 r/min	46 (12) @ 2800 r/min
PVM020	20,1 (1.22)	230 (3300)	250 (3600)	280 (4000)	53 (14) @ 2800 r/min	53 (14) @ 2800 r/min
PVM045	45,1 (2.75)	280 (4000)	320 (4600)	350 (5000)	115 (30) @ 2600 r/min	106 (28) @ 2400 r/min
PVM050	50,0 (3.05)	230 (3300)	250 (3600)	280 (4000)	125 (33) @ 2600 r/min	116 (31) @ 2400 r/min
PVM057	57,4 (3.50)	280 (4000)	320 (4600)	350 (5000)	140 (37) @ 2500 r/min	128 (34) @ 2300 r/min
PVM063	63,1 (3.85)	230 (3300)	250 (3600)	280 (4000)	150 (40) @ 2500 r/min	140 (37) @ 2400 r/min
PVM074	73,7 (4.50)	280 (4000)	320 (4600)	350 (5000)	163 (43) @ 2400 r/min	–
PVM081	81,0 (4.94)	230 (3300)	250 (3600)	280 (4000)	181 (48) @ 2400 r/min	–
PVM098	98,3 (6.00)	280 (4000)	320 (4600)	350 (5000)	200 (53) @ 2200 r/min	–
PVM106	106,5 (6.50)	230 (3300)	250 (3600)	280 (4000)	222 (59) @ 2200 r/min	–
PVM131	131,1 (8.00)	280 (4000)	320 (4600)	350 (5000)	233 (62) @ 2000 r/min	–
PVM141	141,0 (8.60)	230 (3300)	250 (3600)	280 (4000)	258 (68) @ 2000 r/min	–

\*Less than 10% of duty cycle.

\*\*Less than 0.5 second.

### Standard Response Times\*

Model Series	On Stroke (msec)	Off Stroke (msec)
PVM018	50	20
PVM020	57	22
PVM045	140	40
PVM050	140	23
PVM057	65	20
PVM063	94	20

### Standard Response Times\*

Model Series	On Stroke (msec)	Off Stroke (msec)
PVM074	95	30
PVM081	135	30
PVM098	85	24
PVM106	90	25
PVM131	100	30
PVM141	128	28

\*Values with pressure compensator control.

# Specifications and Performance

## Mobile

**Speed, Input Power and Torque Ratings** At 93°C (200°F), SAE 10W oil, 1 bar absolute (0 psig) inlet

Approximate Model Series	Operating Speed and Pressure r/min			Max. Input Power at	Max. Torque at	Weight (dry) kg (lbs)
	1 bar Inlet Flange Ports	Tube Ports	0,85 bar Inlet Flange Ports	Max. Speed and 280 bar (4000 psi) kW (hp)	280 bar (4000 psi) Nm (lb-ft)	
PVM018	2800 r/min			24 (32)	82 (60)	15 (33)
		2800 r/min		24 (32)		
			2600 r/min	22 (30)		
PVM020	2800 r/min			21 (28)	72 (53)	15 (33)
		2800 r/min		21 (28)		
			2600 r/min	20 (27)		
PVM045	2600 r/min			56 (75)	198 (46)	24 (52)
		2400 r/min		53 (71)		
			2200 r/min	48 (64)		
PVM050	2600 r/min			51 (68)	204 (150)	24 (52)
		2400 r/min		48 (64)		
			2200 r/min	44 (59)		
PVM057	2500 r/min			68 (91)	262 (193)	36 (79)
		2300 r/min		62 (83)		
			2100 r/min	56 (75)		
PVM063	2500 r/min			59 (79)	225 (166)	36 (79)
		2400 r/min		57 (76)		
			2200 r/min	52 (69)		
PVM074	2400 r/min			84 (113)	334 (246)	45 (99)
			1900 r/min	69 (93)		
PVM081	2400 r/min			69 (93)	276 (204)	45 (99)
			1900 r/min	55 (74)		
PVM098	2200 r/min			105 (141)	457 (337)	55 (121)
			1800 r/min	86 (115)		
PVM106	2200 r/min			87 (117)	377 (278)	55 (121)
			1800 r/min	70 (94)		
PVM131	2000 r/min			122 (164)	581 (429)	66 (145)
			1600 r/min	98 (131)		
PVM141	2000 r/min			102 (137)	483 (356)	66 (145)
			1600 r/min	81 (109)		

# Control Options

## Pressure Compensator Control – Code A

The pump will provide a continuously modulated flow to meet changing load demands at a pre-adjusted compensator pressure. At pressures below the compensator setting, the pump will operate at maximum displacement. See model code on page 4 for compensator pressure ranges.

**Warning:** The pressure compensator may be adjusted beyond the rated pressure of the pump. When adjusting the pressure limiter, install a 0-350 bar (0-5000 psi) gage in the outlet gage port and limit the pressure setting to the continuous rated pressure for the pump displacement shown on page 7.

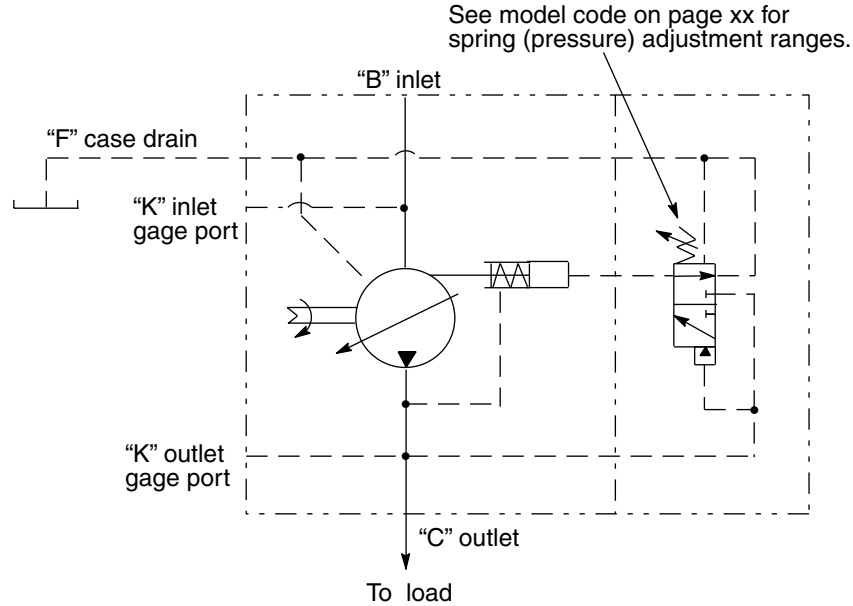

**Industrial Pressure Cut-off Characteristics of Code A Pressure Compensator Control** at 50°C (120°F), static conditions.

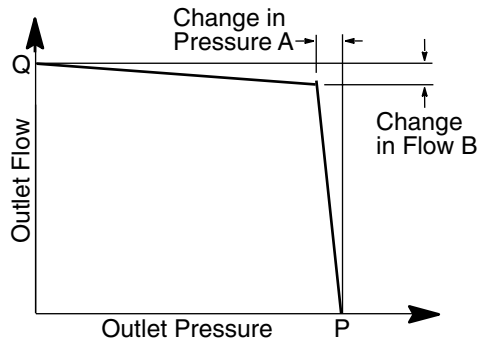

**Pressure Cut-off Characteristics of Pressure Compensator Control @ 50°C (120°F), Static Conditions**

Model Series	Max. Speed r/min	"Q" Outlet Flow l/min (USgpm)	"P" Outlet Pressure	
			bar (psi)	A bar (psi)      B L/min (USgpm)
PVM018	1800	32 (8.5)	280 (4000)	2,8 (40)      4,5 (1.2)
PVM020	1800	35 (9.25)	230 (3300)	2,8 (40)      4,5 (1.2)
PVM045	1800	76 (20)	280 (4000)	10 (150)      4,5 (1.2)
PVM050	1800	87 (23)	230 (3300)	10 (150)      4,5 (1.2)
PVM057	1800	102 (27)	280 (4000)	3,5 (51)      14 (3.7)
PVM063	1800	113 (29)	230 (3300)	7,4 (107)      7,6 (2.00)
PVM074	1800	127 (33.5)	280 (4000)	1,5 (22)      37 (9.8)
PVM081	1800	141 (37)	230 (3300)	1,5 (22)      37 (9.8)
PVM098	1800	179 (47)	280 (4000)	1,5 (22)      25 (6.6)
PVM106	1800	195 (51.5)	230 (3300)	1,5 (22)      20 (5.3)
PVM131	1800	229 (60.5)	280 (4000)	3,5 (51)      19 (5.0)
PVM141	1800	238 (63)	230 (3300)	3,5 (51)      14 (3.70)

# Control Options

**Mobil Pressure Cut-off Characteristics of Pressure Compensator Control** at 93°C (200°F), static conditions.

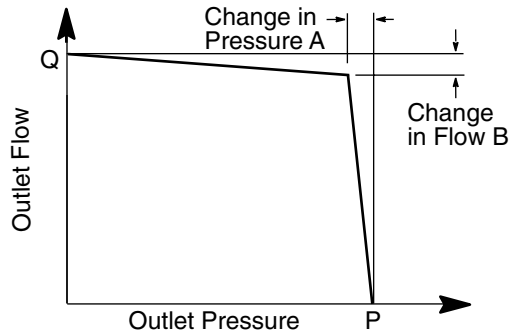

**Pressure Cut-off Characteristics of Pressure Compensator Control @ 93°C (200°F), Static Conditions**

Model Series	Rated Speed r/min	"Q" Outlet Flow l/min (USgpm)	"P" Outlet		
			Pressure bar (psi)	A bar (psi)	B L/min (USgpm)
PVM018	2800	42 (11)	280 (4000)	2,8 (40)	4,5 (1.2)
PVM020	2800	52 (14)	230 (3300)	2,8 (41)	4,5 (1.2)
PVM045	2600	115 (30)	280 (4000)	10 (150)	4,5 (1.2)
PVM050	2600	125 (33)	230 (3300)	10 (150)	4,5 (1.2)
PVM057	2500	140 (37)	280 (4000)	3,5 (50)	14 (3.7)
PVM063	2500	159 (42)	230 (3300)	7,4 (107)	11,4 (3.00)
PVM074	2400	174 (46)	280 (4000)	1,5 (20)	37 (9.8)
PVM081	2400	185 (49)	230 (3300)	1,5 (22)	37 (9.8)
PVM098	2200	217 (57)	280 (4000)	1,5 (20)	32 (8.4)
PVM106	2200	234 (62)	230 (3300)	1,5 (22)	24 (6.33)
PVM131	2000	253 (67)	280 (4000)	1,0 (15)	23 (6.0)
PVM141	2000	258 (68)	230 (3300)	7,0 (100)	14 (3.70)

# Control Options

## Load Sensing and Pressure Compensator Control – Code B or C

The pump will provide power matching of pump output to system load demand, maximizing efficiency and improving load metering characteristics of any directional control valve installed between the pump and the load.

Load sensing ensures that the pump always provides only the amount of flow needed by the load. At the same time, the pump operating pressure adjusts to the actual load pressure plus a pressure differential required for the control action. When the system is not demanding power, the load sense control will operate in an energy-saving stand-by mode.

Typically, the differential pressure is that between the pressure inlet and service port of a proportionally controlled directional valve, or a load sensing directional control valve. See the model code on page 4 for differential pressure settings for load sensing.

If the load pressure exceeds the system pressure setting, the pressure compensator de-strokes the pump. The load sensing line must be as short as possible and can also be used for remote control or unloading of the pump pressure. For remote control purposes, it is recommended that you contact your Eaton representative for the correct configuration of the control.

**Warning:** The pressure compensator may be adjusted beyond the rated pressure of the pump. When adjusting the pressure limiter, install a 0-350 bar (0-5000 psi) gage in the outlet gage port and limit the pressure setting to the continuous rated pressure for the pump displacement shown on page 7.

Optional bleed-down orifice in Code B control. 0,4 mm (.016 in.) Orifice is plugged for no bleed down in control Code C.

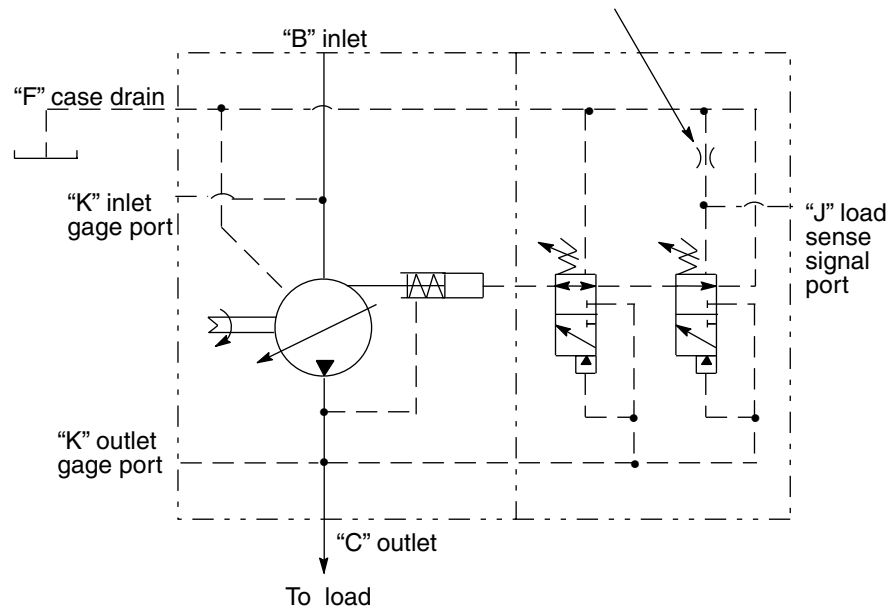

# Control Options

## Industrial Control Compensator – Code E & F (Model 057-141 only)

This pump is intended for use when multiple, remote, or electronically controlled compensating settings, with or without load sensing, are desired.

Pressure compensation is obtained when an internal plug is removed, the load-sense signal port is kept plugged, and internal pilot pressure is applied to the spring chamber of the control spool. For pressure compensation with load sensing, the internal plug stays, the load-sense signal port is unplugged, and pilot pressure is externally applied.

An external relief valve (not supplied) controls spring chamber pressure. The externally adjustable spring determines the differential pressure setting of the control. Outlet pressure is limited to the valve of the spring chamber (pressure port) pressure, plus control differential pressure.

Spring chamber (pilot) pressure is separated from outlet pressure by an internal orifice. Outlet pressure shifts the spool when pressure drop across the orifice reaches the differential pressure setting, and the pump de-strokes.

The relief valve can be mounted to an NFPA-D03/ISO 4401-03 pad on the pump control, or remotely located via tapping and blanking plates installed on the pad. See "Ordering Procedure", page 27, for more on valves and plates.

The standard factory-set differential pressure setting of the pump control is 20 bar (290 psi) and is not specified in the pump model number. Any other ordered differential pressure, within the control's adjustable pressure range of 17-35 bar (247-508 psi), will be specified in the model number.

### With Pressure & Flow Compensator (E)

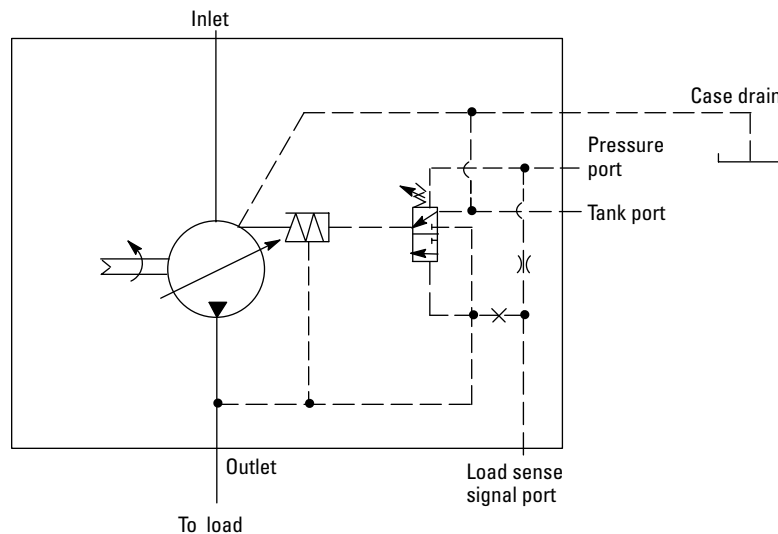

### Pressure Compensating Without Load Sensing (F)

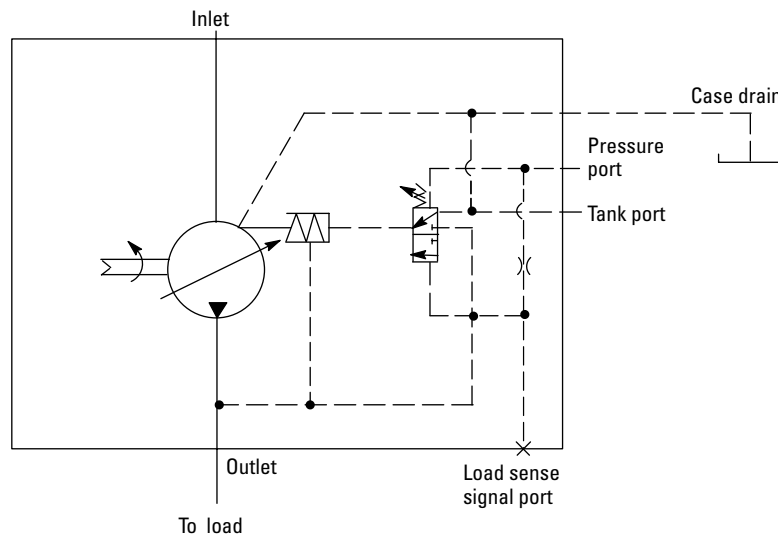

# Performance

Industrial PVM018

**Typical Noise Levels at 1800 and 1200 r/min with Petroleum Oil (10W) at 50°C (120°F) and 1.0 bar absolute (0 psi gauge) Inlet**

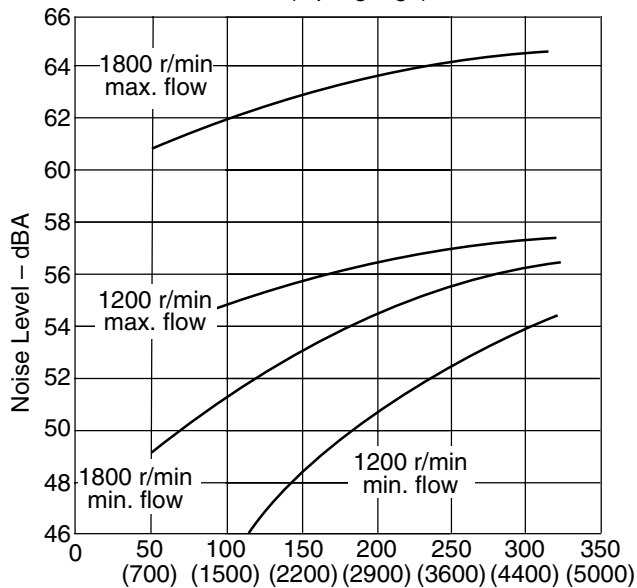

Sound pressure data equivalent to NFPA. Outlet Pressure – bar (psi)

**Delivery and Efficiency at 1800 r/min 50°C (120°F) and 1.0 bar absolute (0 psi gauge) Inlet**

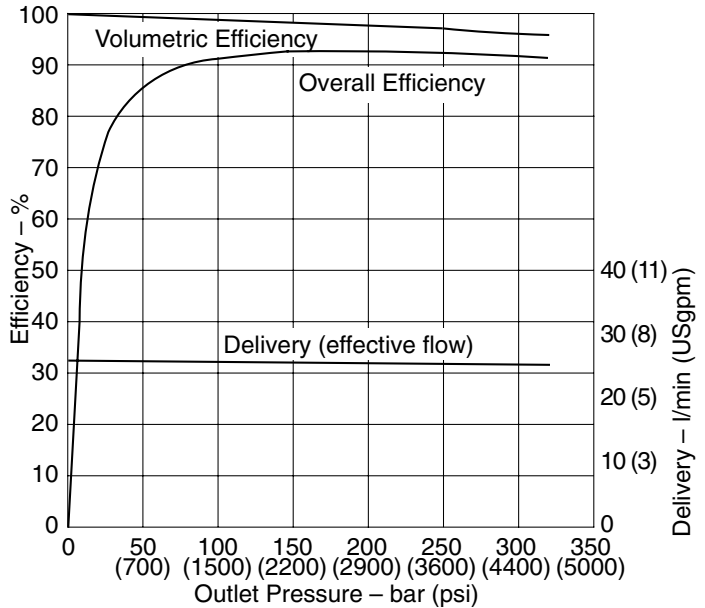

**Typical Noise Levels at 1500 and 1000 r/min with Petroleum Oil (10W) at 50°C (120°F) and 1.0 bar absolute (0 psi gauge) Inlet**

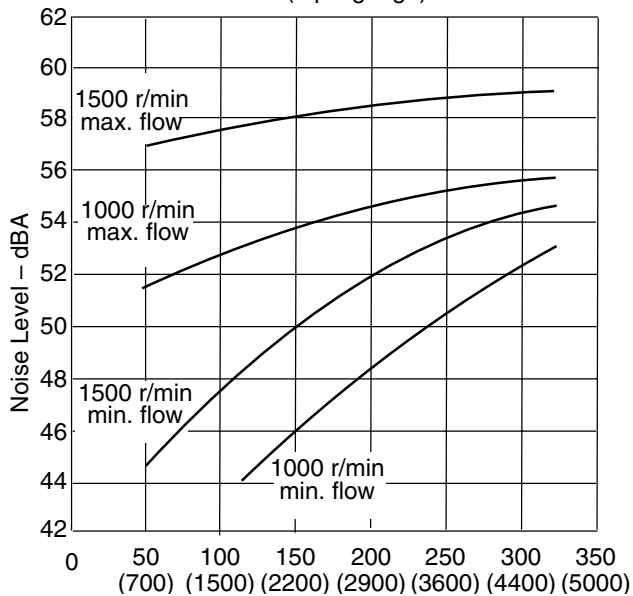

**Input Torque and Power at 1800 r/min 50°C (120°F) and 1.0 bar absolute (0 psi gauge) Inlet**

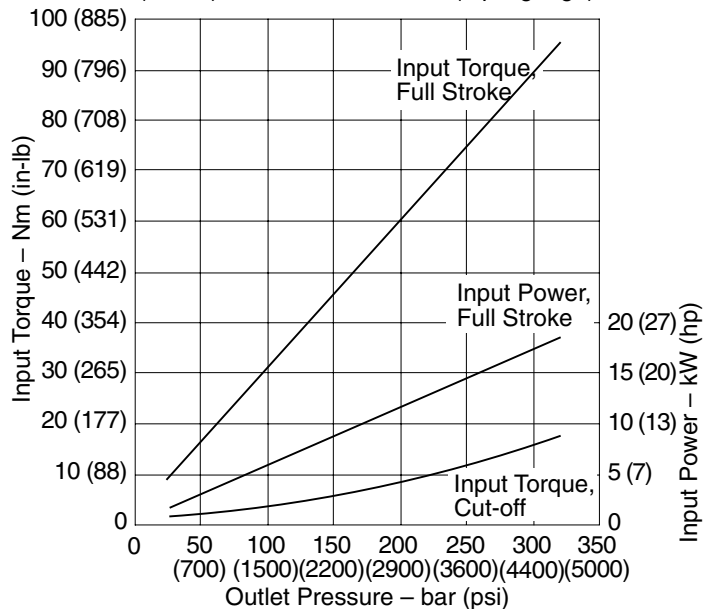

# Performance

Industrial PVM018

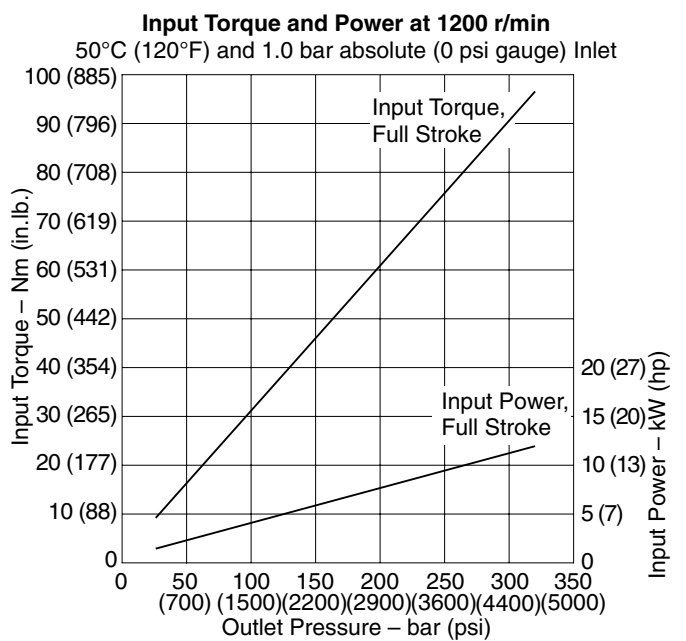
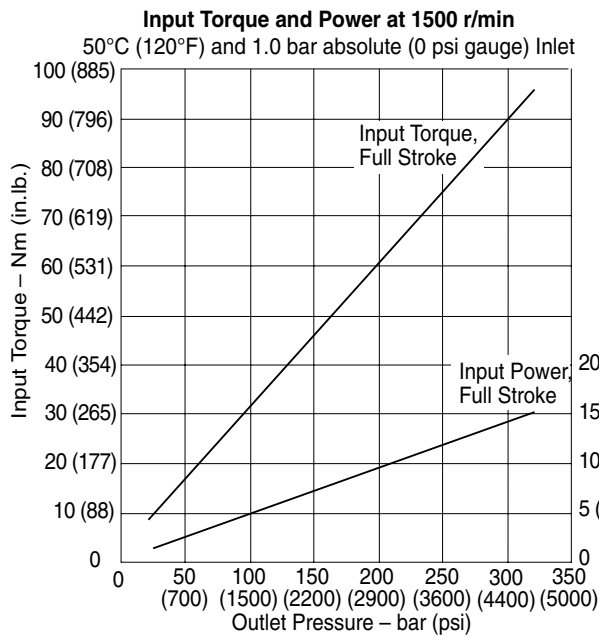
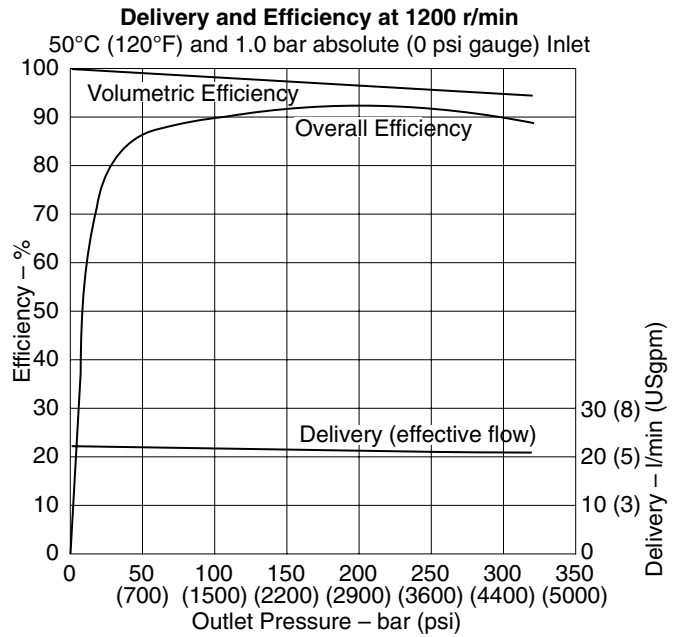
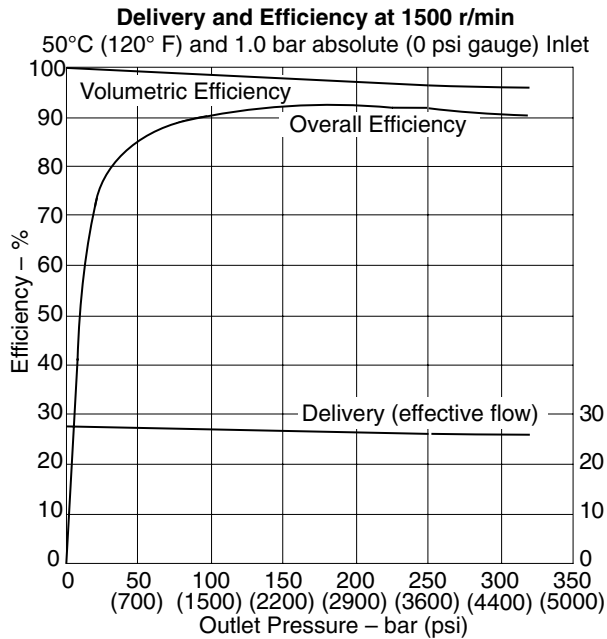



# Performance

Industrial PVM018

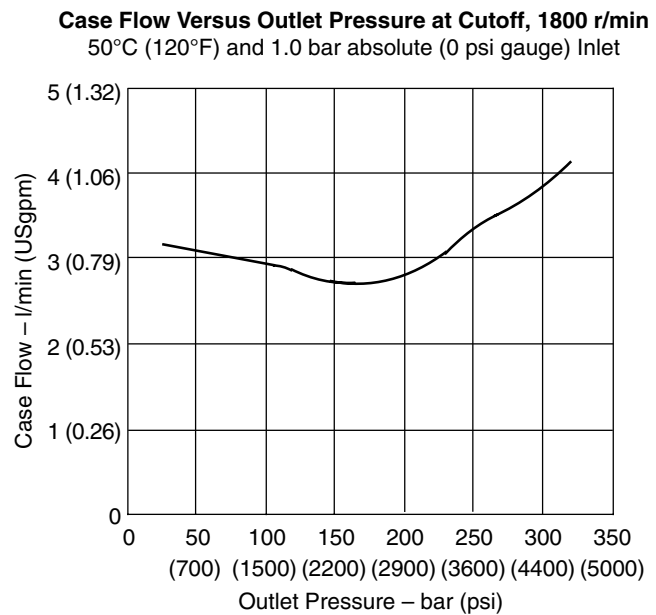
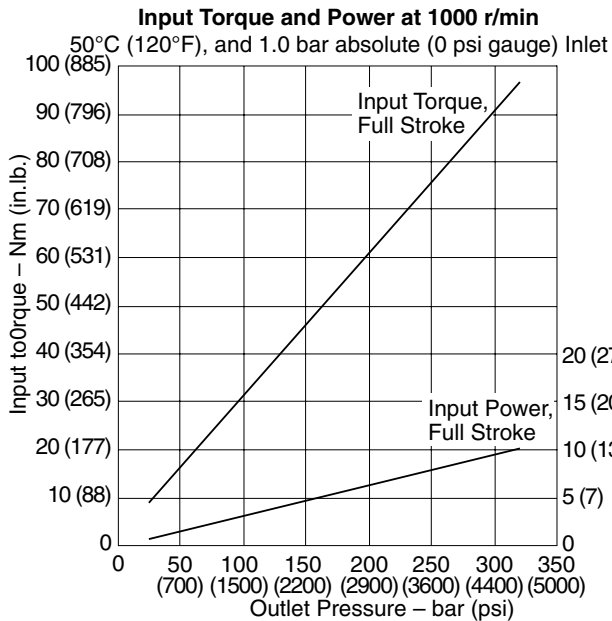
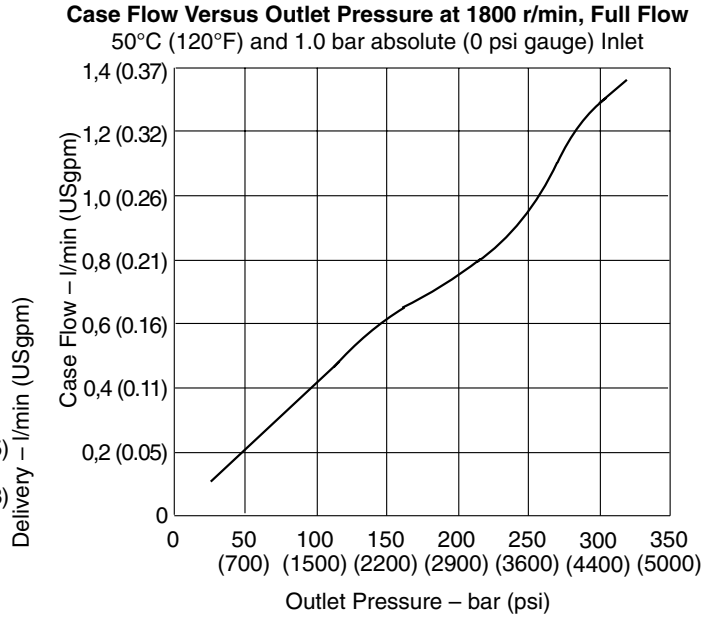
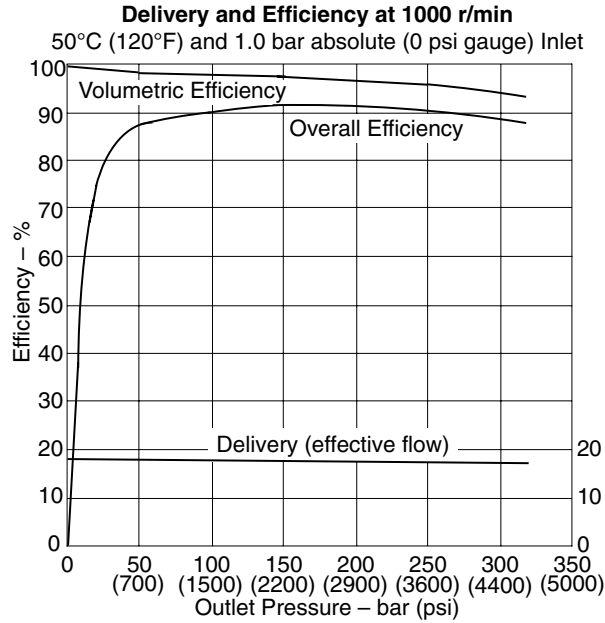

# Performance

Mobile PVM018

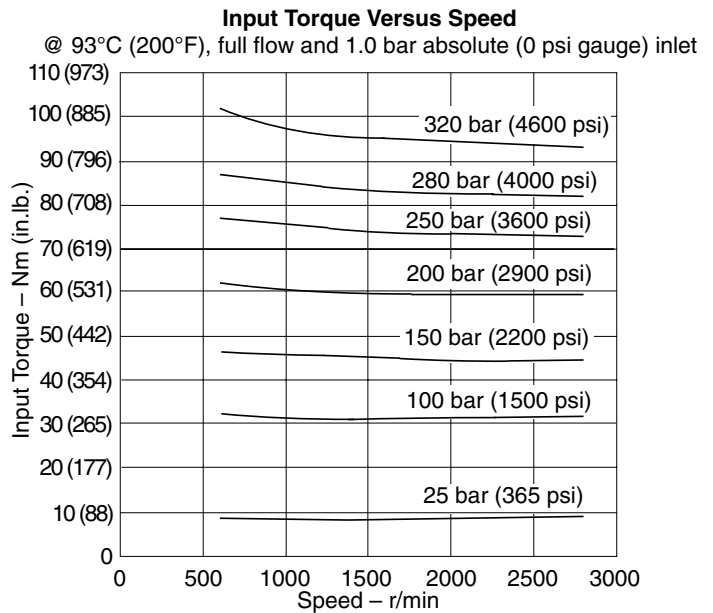
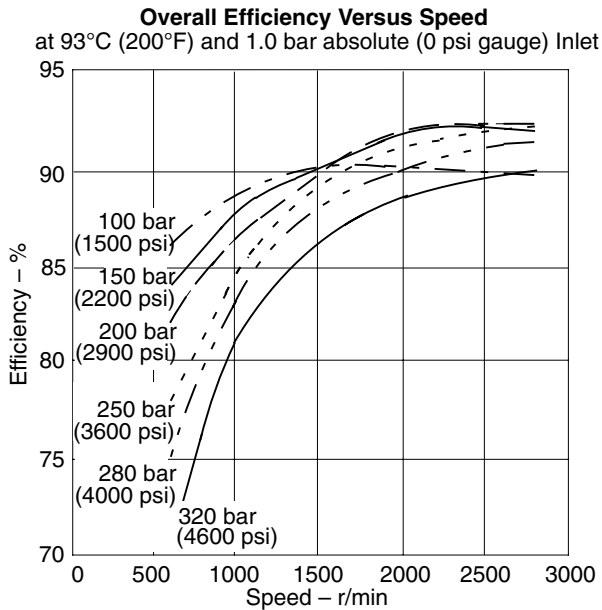
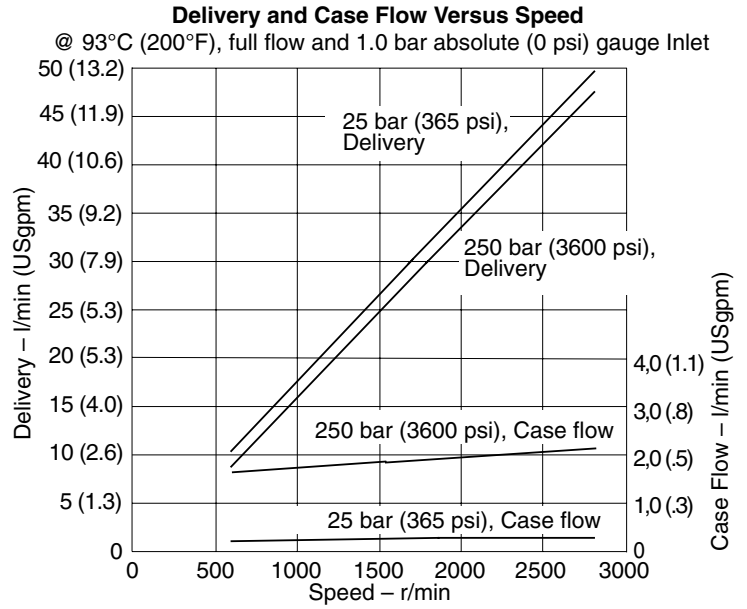
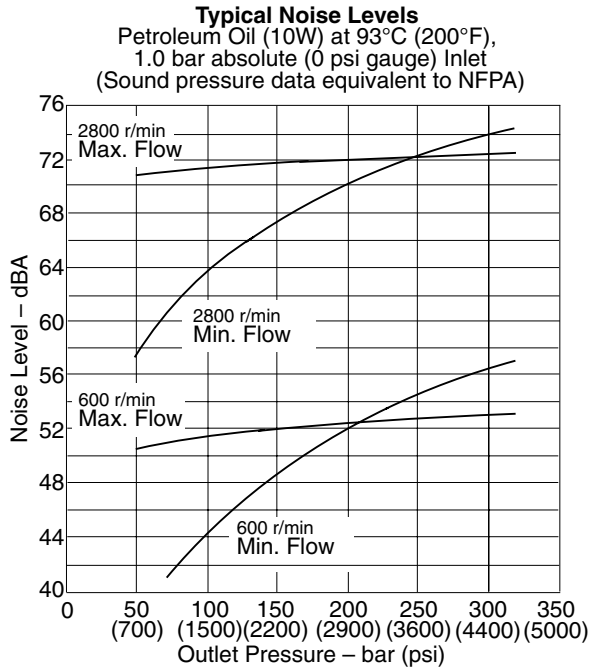

# Performance

Mobile PVM018

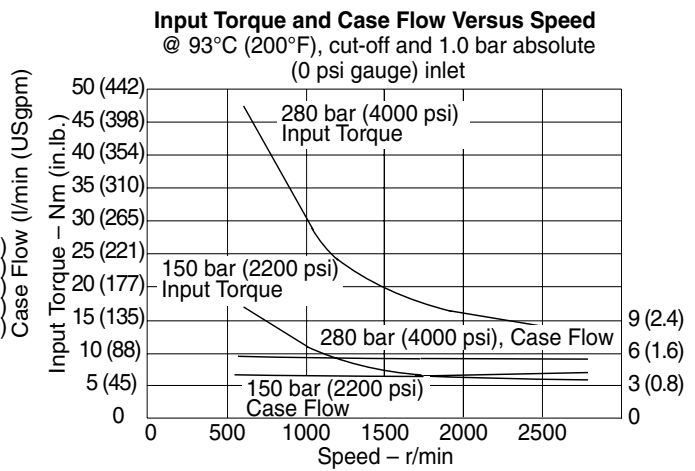
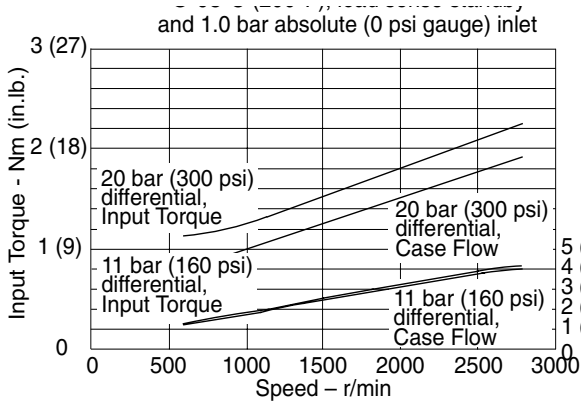
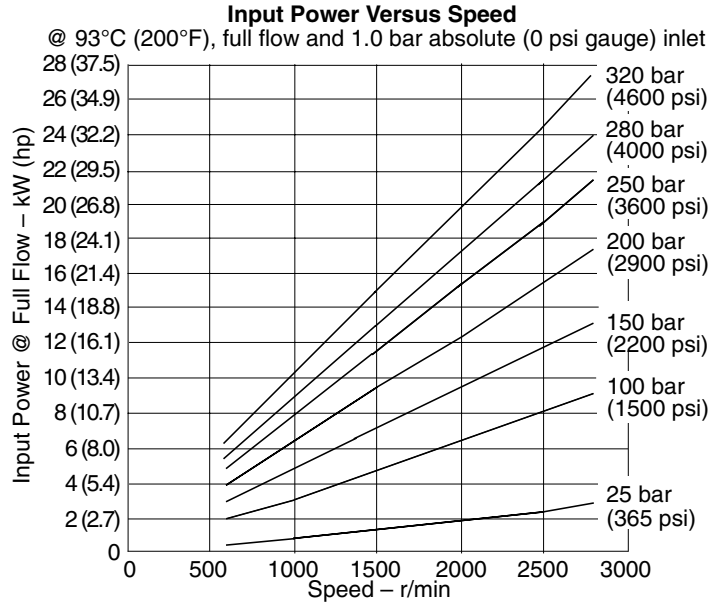

# Performance

Industrial PVM020

**Typical Noise Levels at 1800 and 1200 r/min**  
with Petroleum Oil (10W) at 50°C (120°F)  
and 1.0 bar absolute (0 psi gauge) Inlet

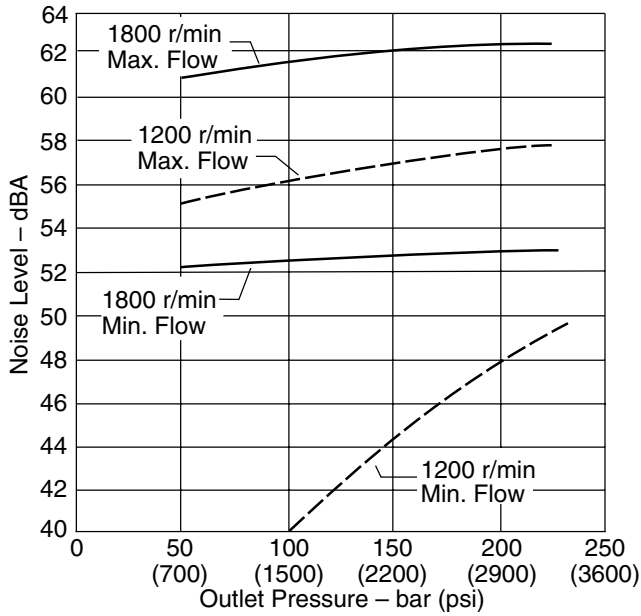

**Delivery and Efficiency at 1800 r/min, 50°C (120°F),  
and 1.0 bar absolute (0 psi gauge) Inlet**

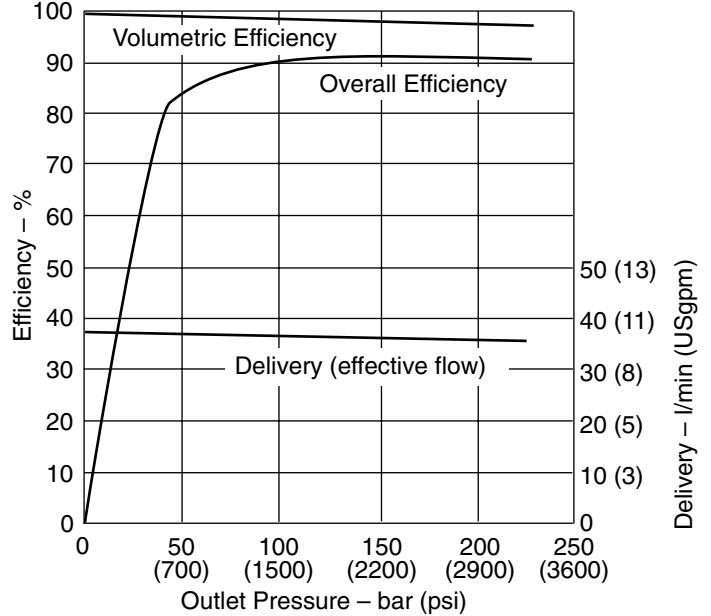

**Typical Noise Levels at 1500 and 1000 r/min**  
with Petroleum Oil (10W) at 50°C (120°F)  
and 1.0 bar absolute (0 psi gauge) Inlet

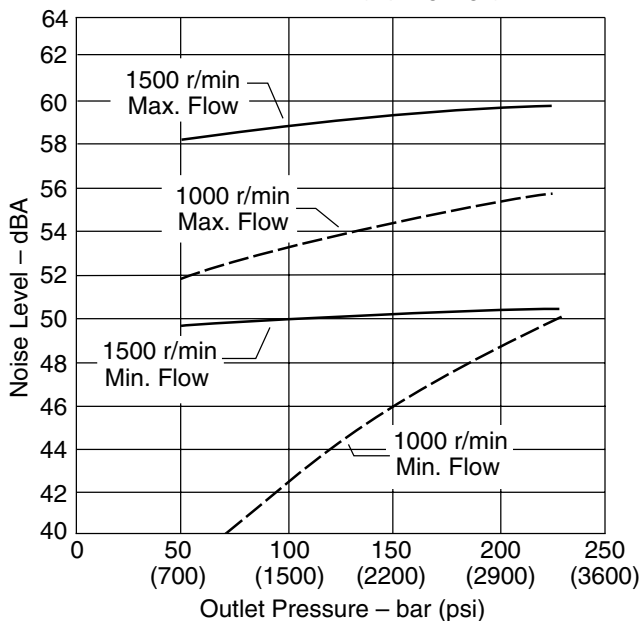

**Input Torque and Power at 1800 r/min, 50°C (120°F),  
and 1.0 bar absolute (0 psi gauge) Inlet**

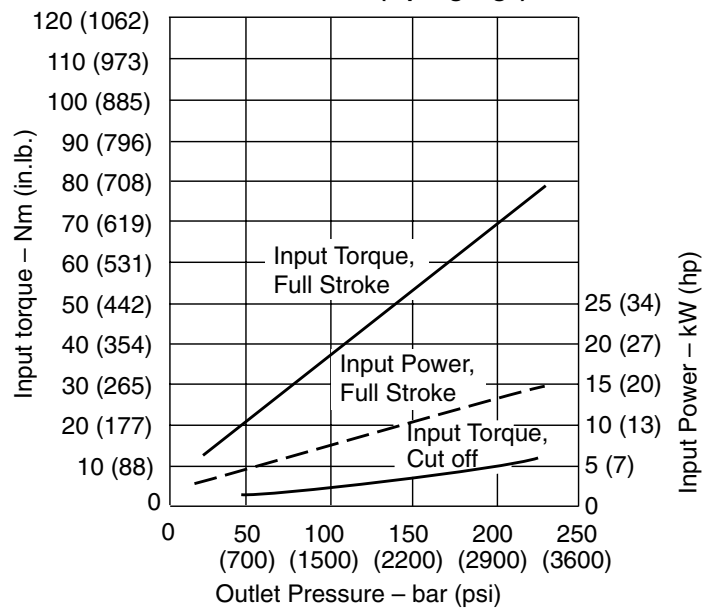

Sound pressure data  
equivalent to NFPA

# Performance

Industrial PVM020

**Delivery and Efficiency at 1500 r/min, 50°C (120°F), and 1.0 bar absolute (0 psi gauge) Inlet**

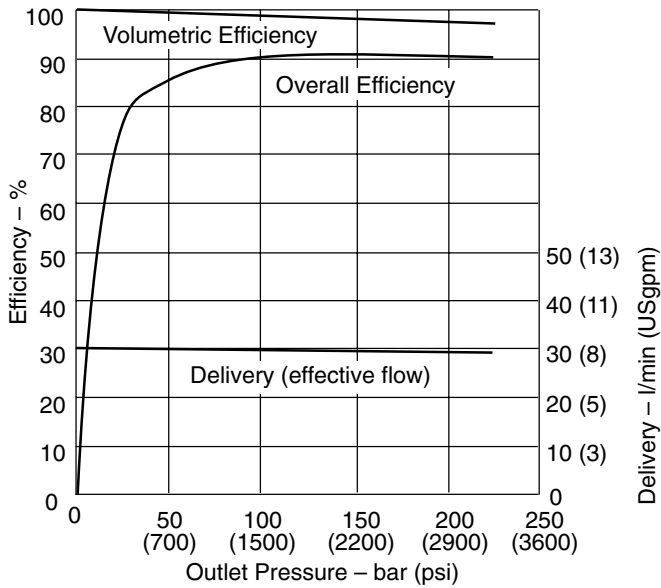

**Delivery and Efficiency at 1200 r/min, 50°C (120°F), and 1.0 bar absolute (0 psi gauge) Inlet**

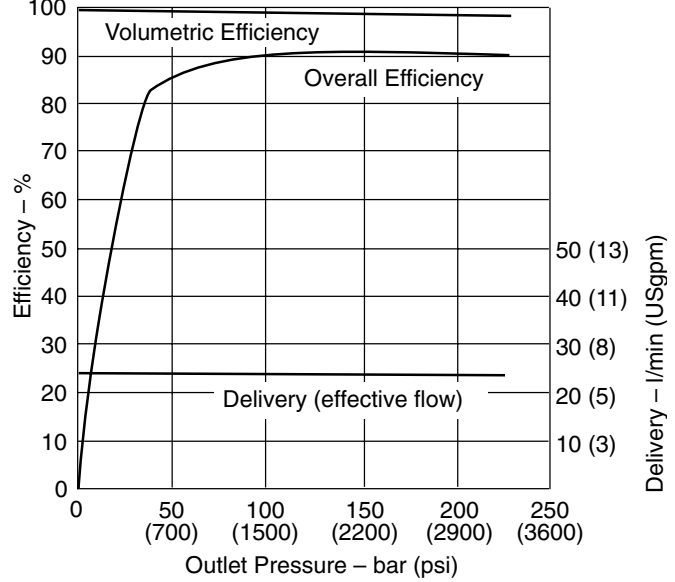

**Input Torque and Power at 1500 r/min, 50°C (120°F), and 1.0 bar absolute (0 psi gauge) Inlet**

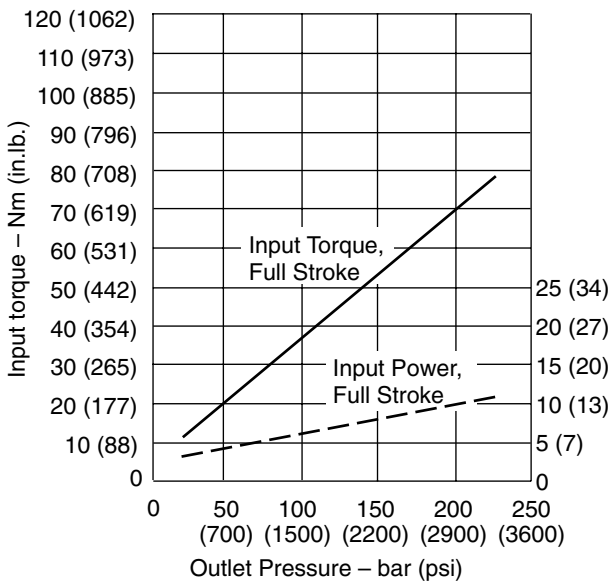

**Input Torque and Power at 1200 r/min, 50°C (120°F), and 1.0 bar absolute (0 psi gauge) Inlet**

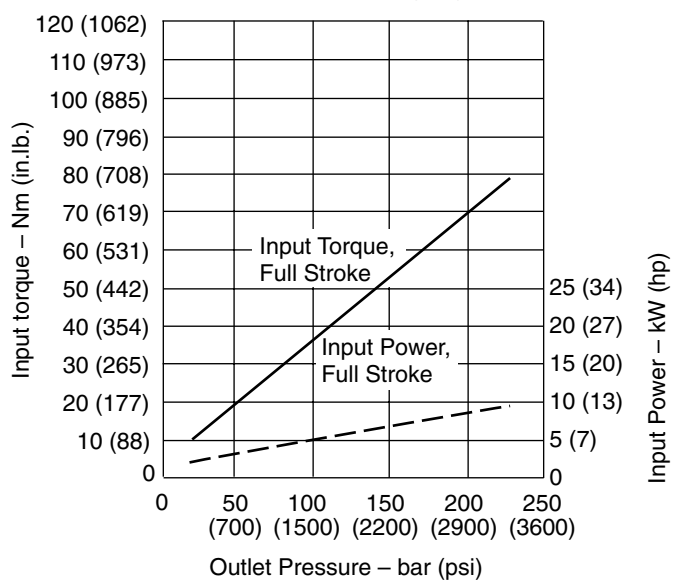

# Performance

Industrial PVM020

**Delivery and Efficiency at 1000 r/min, 50°C (120°F), and 1.0 bar absolute (0 psi gauge) Inlet**

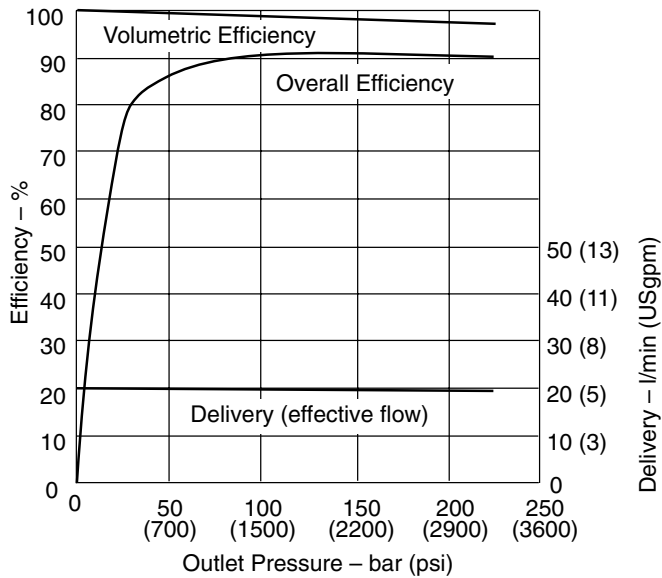

**Case Flow versus Outlet Pressure at 1800 r/min, Full Flow, 50°C (120°F), and 1.0 bar absolute (0 psi gauge) Inlet**

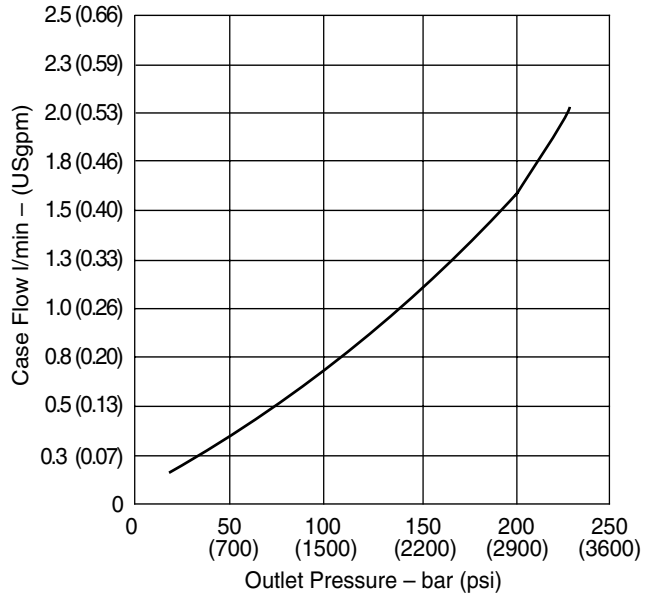

**Input Torque and Power at 1000 r/min, 50°C (120°F), and 1.0 bar absolute (0 psi gauge) Inlet**

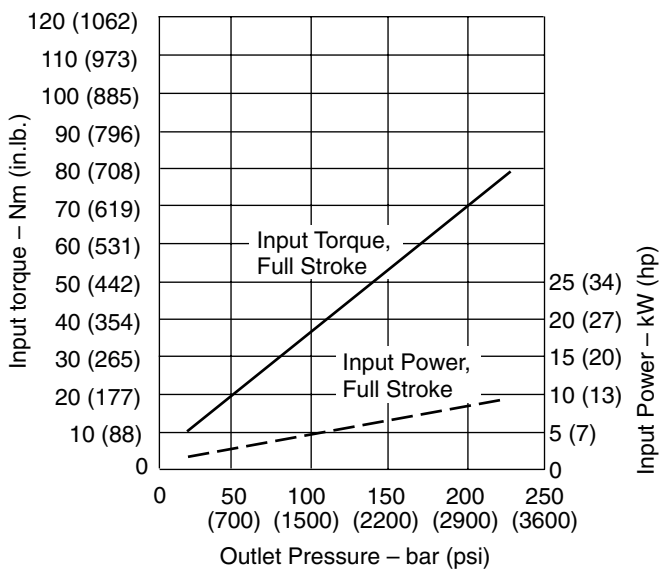

**Case Flow versus Outlet Pressure at Cutoff, 1800 r/min, 50°C (120°F), and 1.0 bar absolute (0 psi gauge) Inlet**

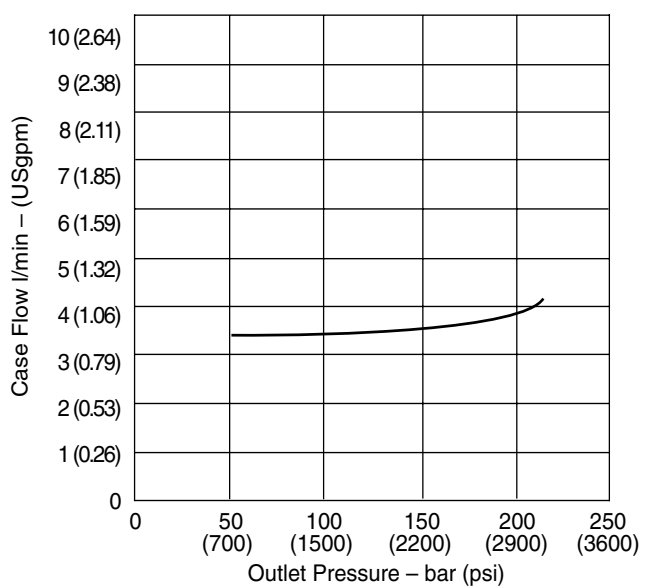

# Performance

Mobile PVM020

**Typical Noise Levels at 2800 & 600 r/min with Petroleum Oil (10W) at 93°C (200°F) and 1.0 bar absolute (0 psi gauge) Inlet**

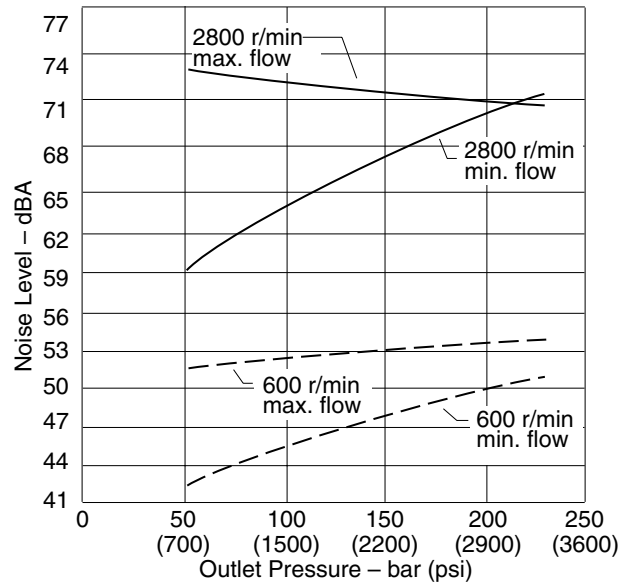

Sound pressure data equivalent to NFPA.

**Overall Efficiency versus Speed at 93°C (200°F) and 1.0 bar absolute (0 psi gauge) inlet**

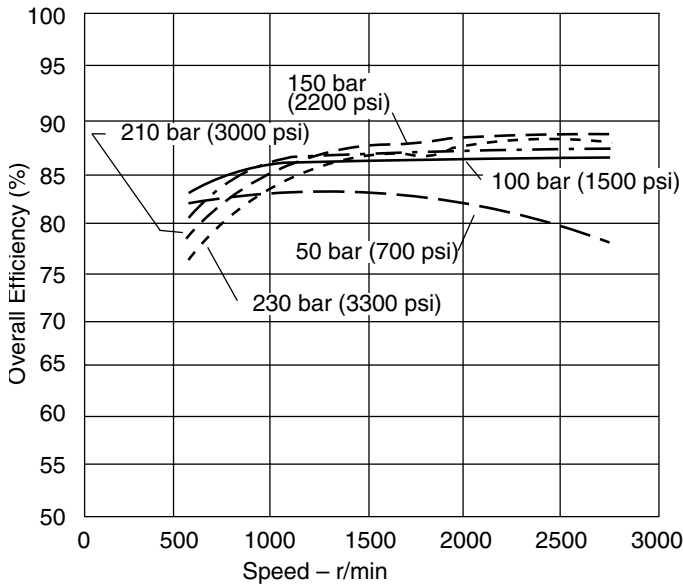

**Delivery and Case Flow versus Speed at 93°C (200°F), Full Flow 1.0 bar absolute (0 psi gauge) inlet**

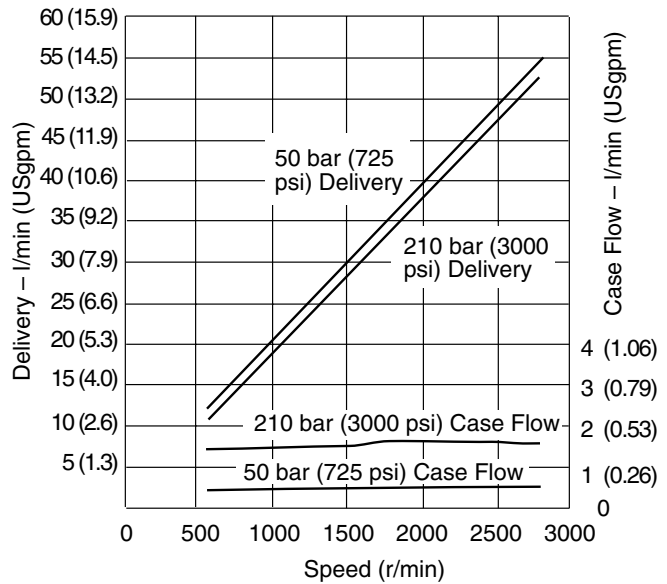

# Performance

Mobile PVM020

**Input Torque versus Speed at 93°C (200°F), Full Flow and 1.0 bar absolute (0 psi gauge) Inlet**

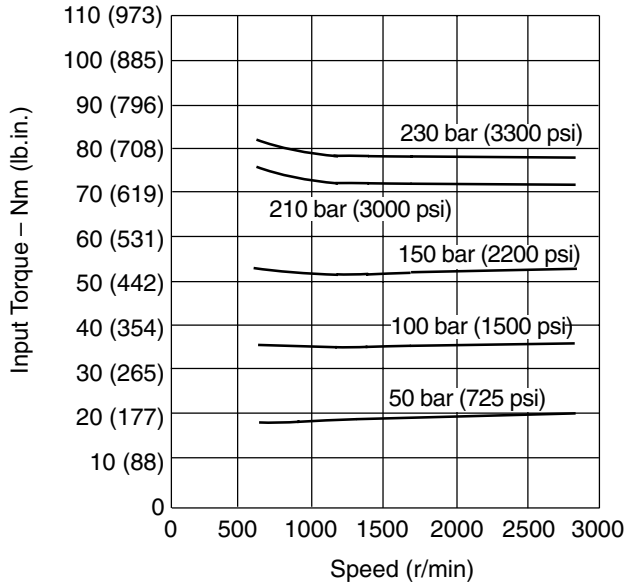

**Input Power versus Speed at 93°C (200°F), Full Flow and 1.0 bar absolute (0 psi gauge) Inlet**

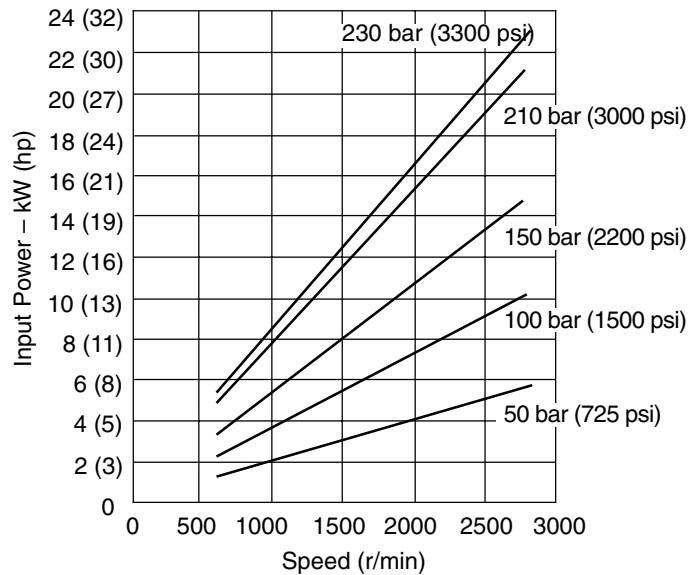

**Input Torque and Case Flow versus Speed at 93°C (200°F), Load Sense Standby and 1.0 bar absolute (0 psi gauge) Inlet**

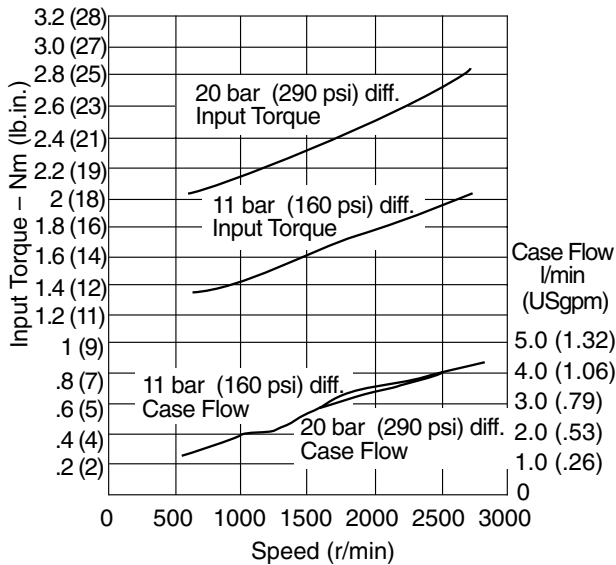

**Input Torque and Case Flow versus Speed at 93°C (200°F), Pressure Limit Cut-off and 1.0 bar absolute (0 psi gauge) Inlet**

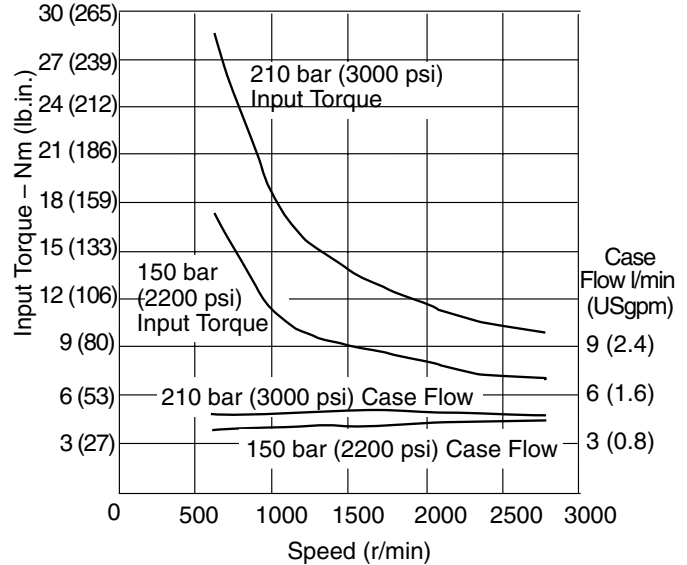



# Performance

Industrial PVM045

**Typical Noise Levels at 1800 and 1200 r/min**  
with Petroleum Oil (10W) at 50°C (120°F)  
and 1.0 bar absolute (0 psi gauge) Inlet

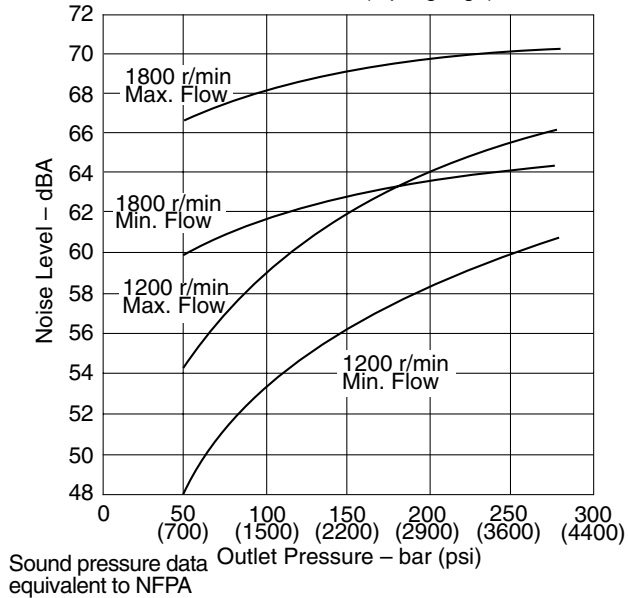

**Delivery and Efficiency at 1800 r/min**  
50°C (120°F) and 1.0 bar absolute (0 psi gauge) Inlet

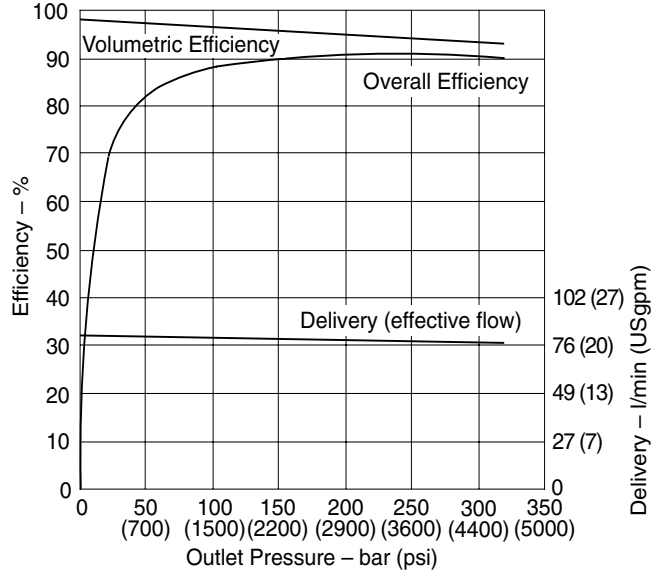

**Typical Noise Levels at 1500 and 1000 r/min**  
with Petroleum Oil (10W) at 50°C (120°F)  
and 1.0 bar absolute (0 psi gauge) Inlet

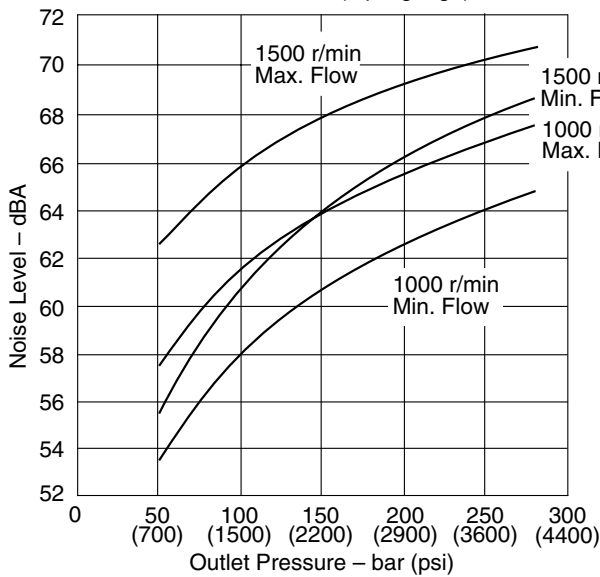

**Input Torque and Power at 1800 r/min**  
50°C (120°F) and 1.0 bar absolute (0 psi gauge) Inlet

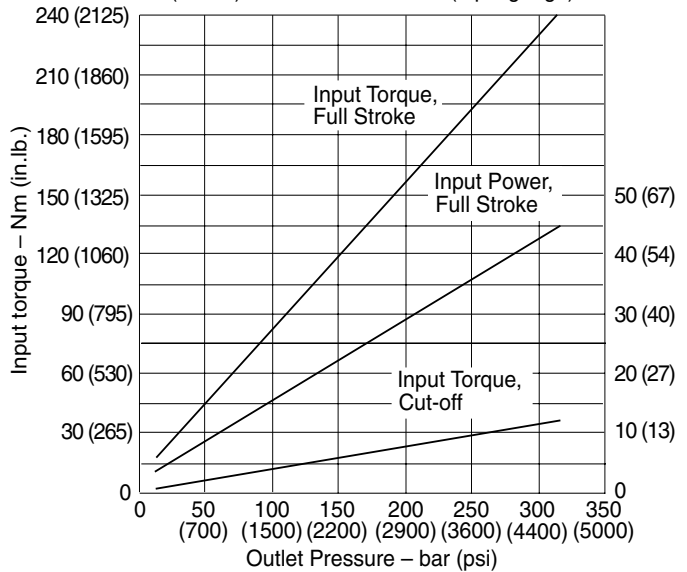

# Performance

Industrial PVM045

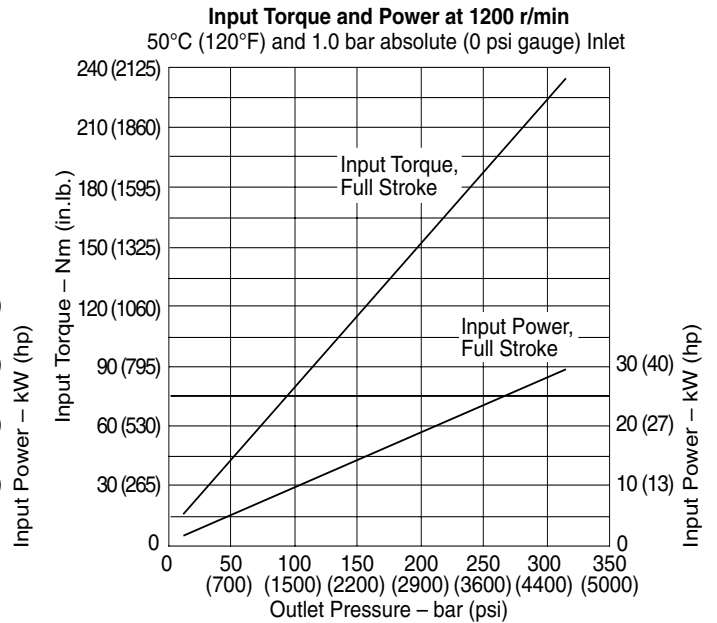
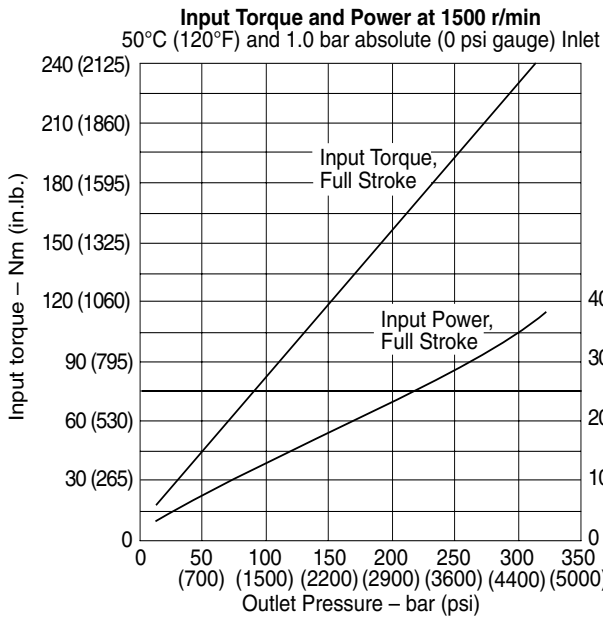
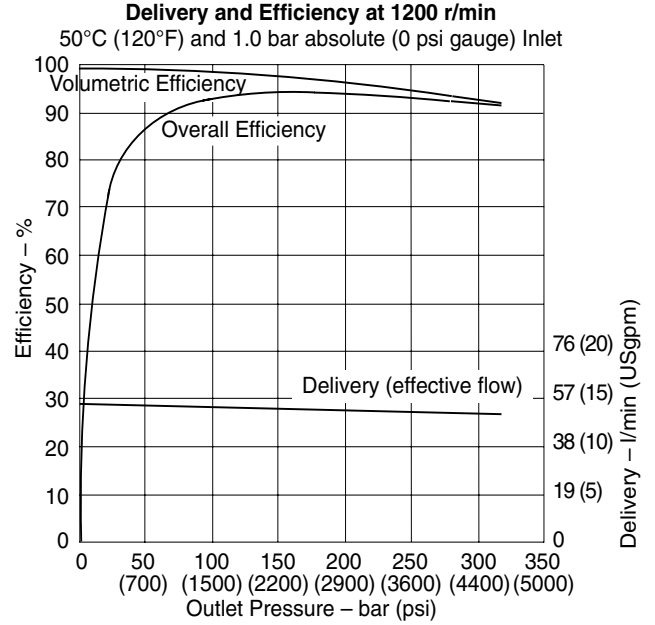
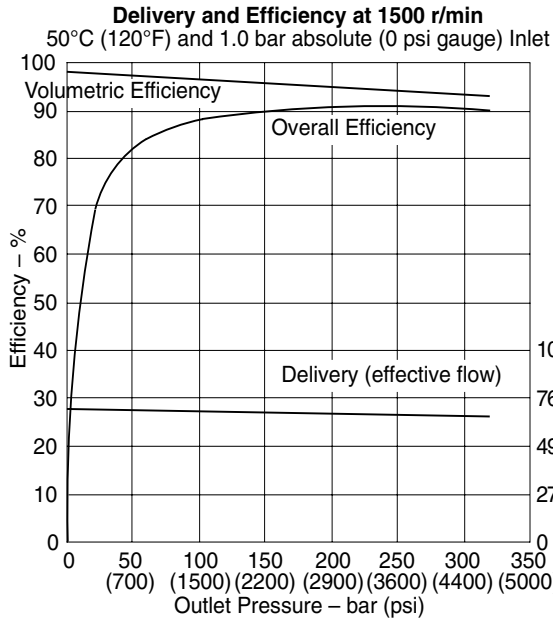

# Performance

Industrial PVM045

**Delivery and Efficiency at 1000 r/min**

50°C (120°F) and 1.0 bar absolute (0 psi gauge) Inlet

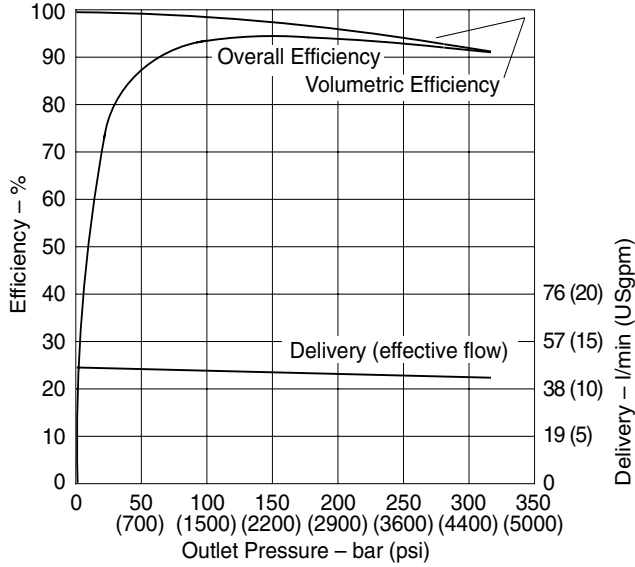

**Case Flow Versus Outlet Pressure at 1800 r/min, Full Flow**

50°C (120°F) and 1.0 bar absolute (0 psi gauge) Inlet

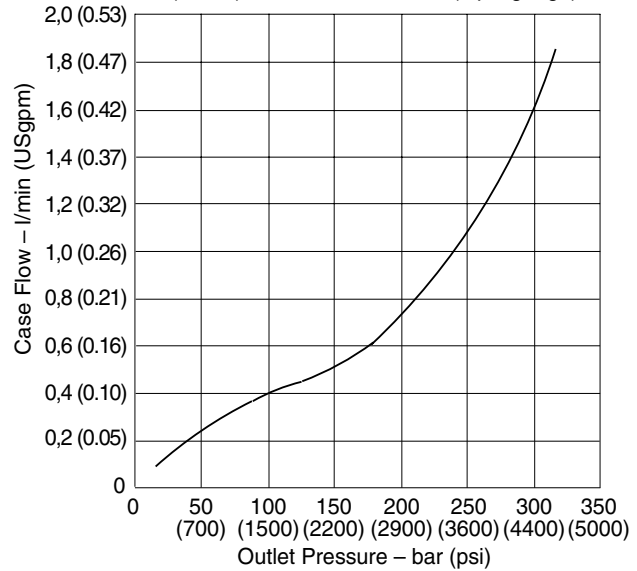

**Input Torque and Power at 1000 r/min**

50°C (120°F), and 1.0 bar absolute (0 psi gauge) Inlet

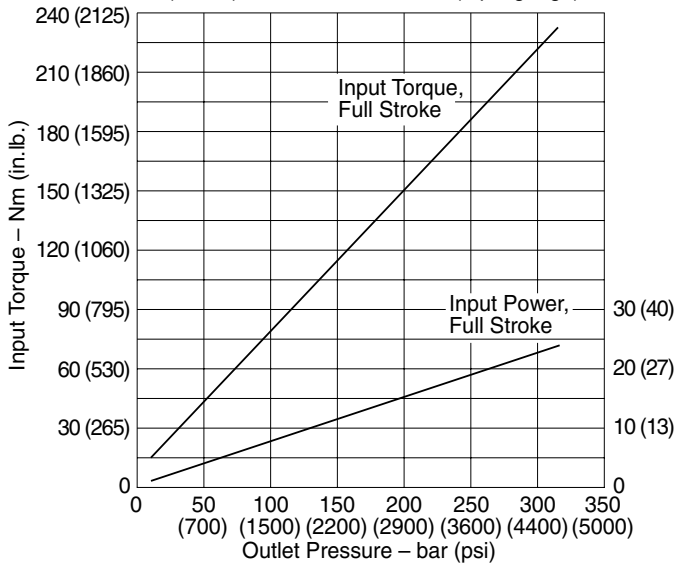

**Case Flow Versus Outlet Pressure at Cutoff, 1800 r/min**

50°C (120°F) and 1.0 bar absolute (0 psi gauge) Inlet

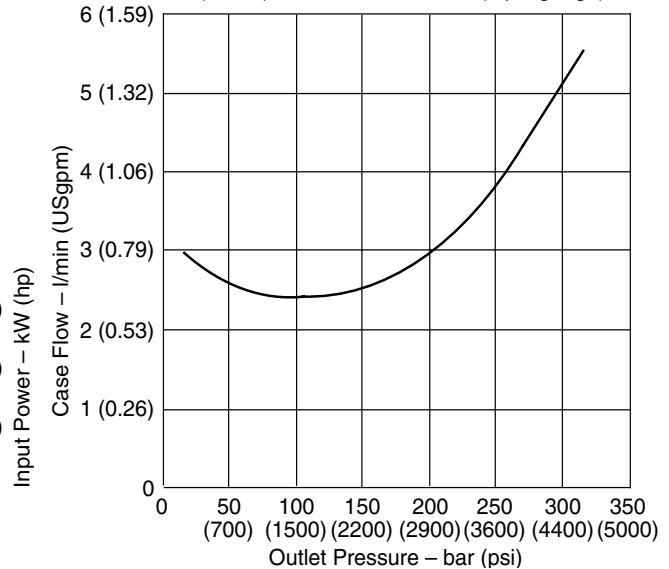

# Performance

Mobile PVM045

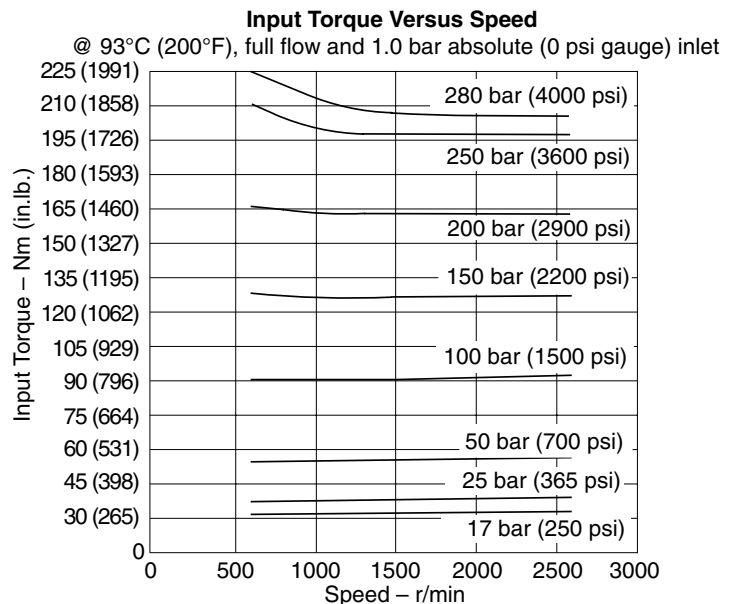
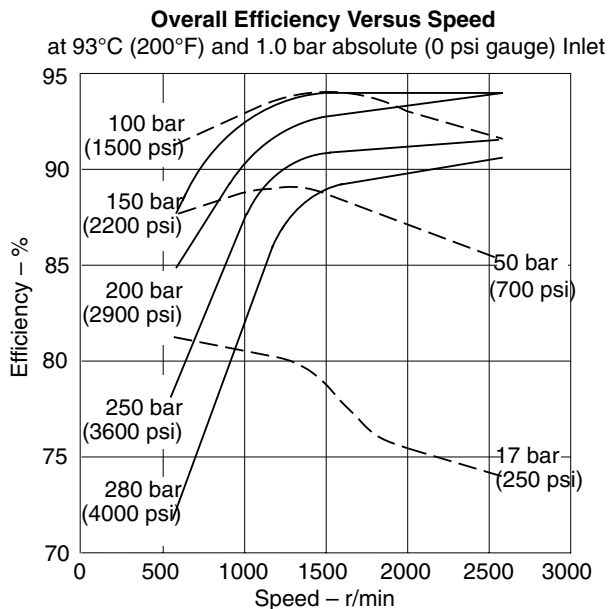
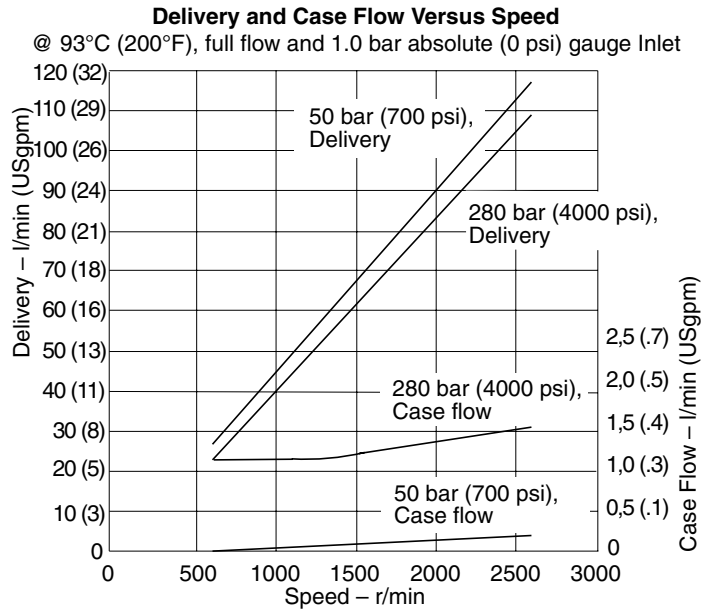
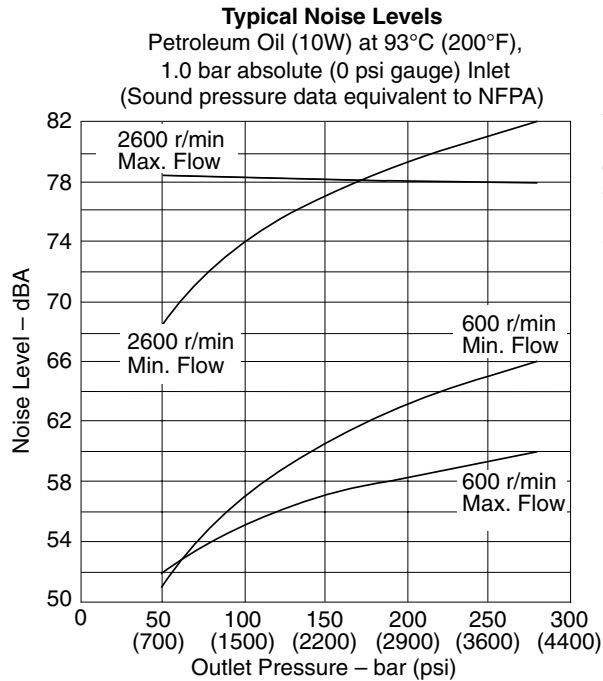

# Performance

Mobile PVM045

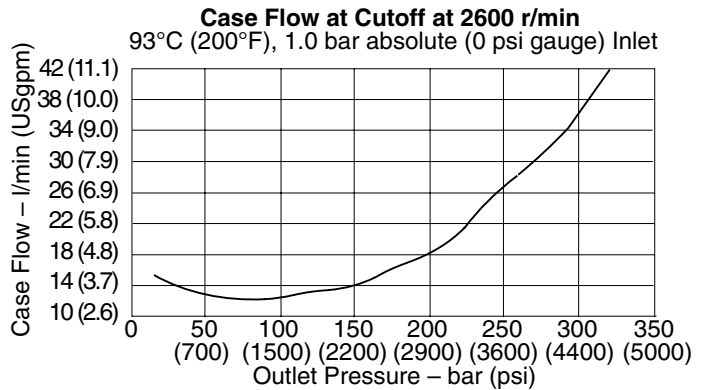
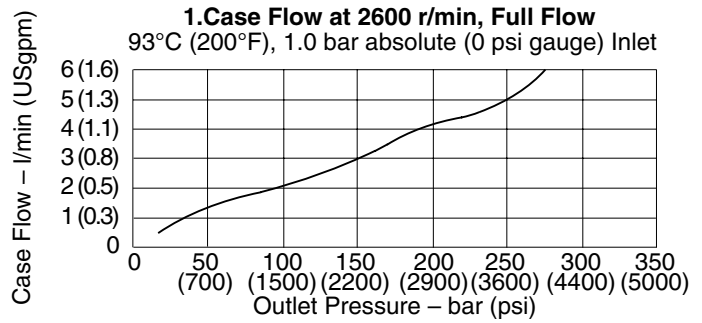
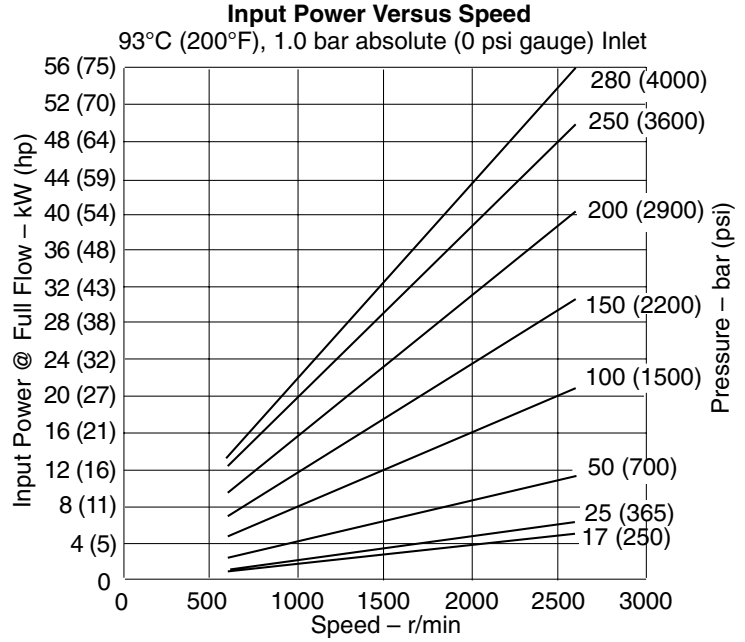

# Performance

Industrial PVM050

**Typical Noise Levels at 1800 and 1200 r/min with Petroleum Oil (10W) at 50°C (120°F) and 1.0 bar absolute (0 psi gauge) Inlet**

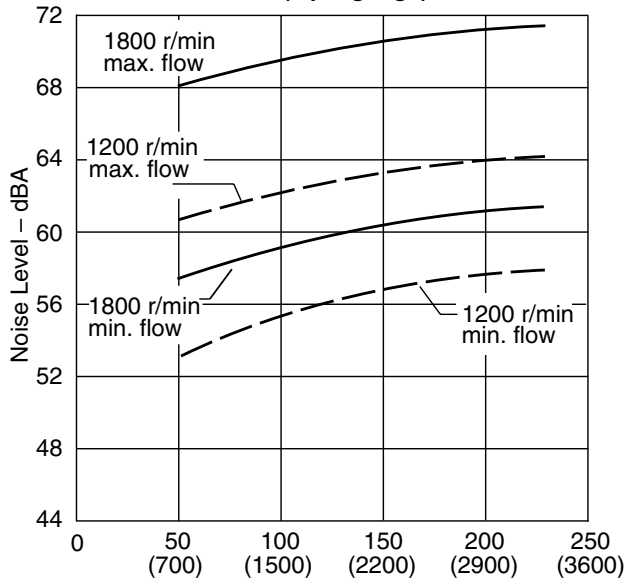

**Delivery and Efficiency at 1800 r/min, 50°C (120°F), and 1.0 bar absolute (0 psi gauge) Inlet**

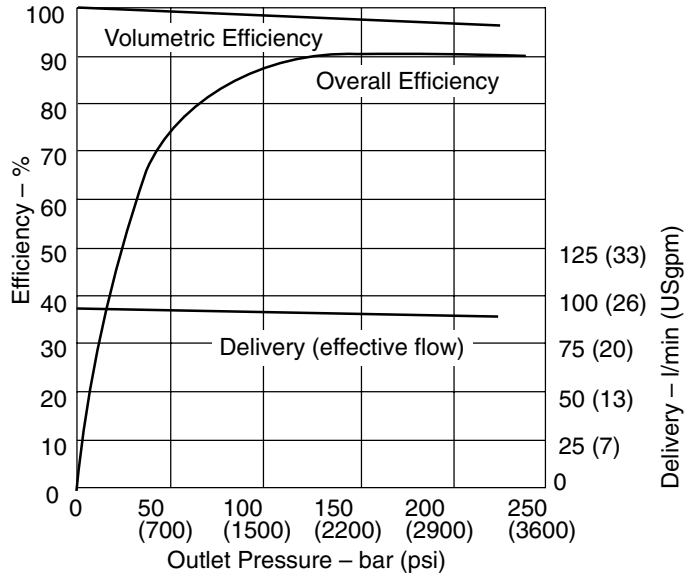

**Typical Noise Levels at 1500 and 1000 r/min with Petroleum Oil (10W) at 50°C (120°F) and 1.0 bar absolute (0 psi gauge) Inlet**

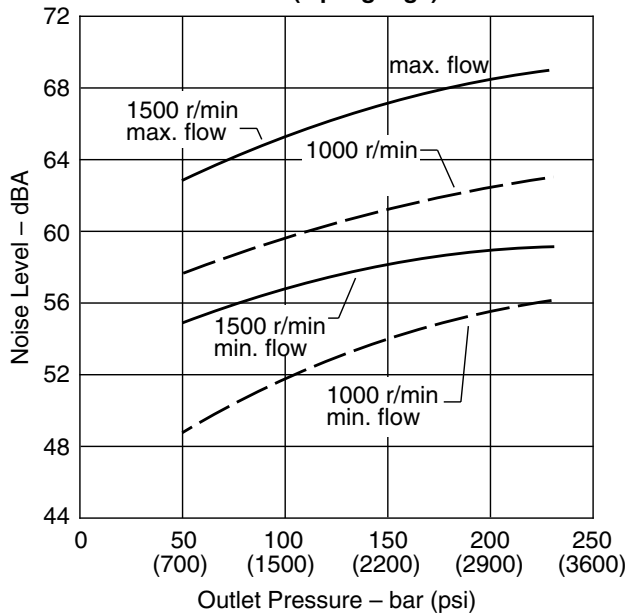

**Input Torque and Power at 1800 r/min, 50°C (120°F), and 1.0 bar absolute (0 psi gauge) Inlet**

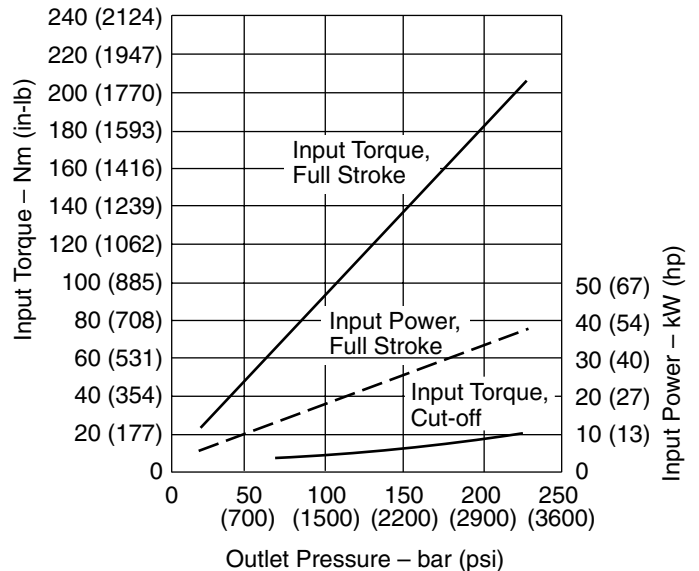

Sound pressure data

# Performance

Industrial PVM050

**Delivery and Efficiency at 1500 r/min, 50°C (120°F), and 1.0 bar absolute (0 psi gauge) Inlet**

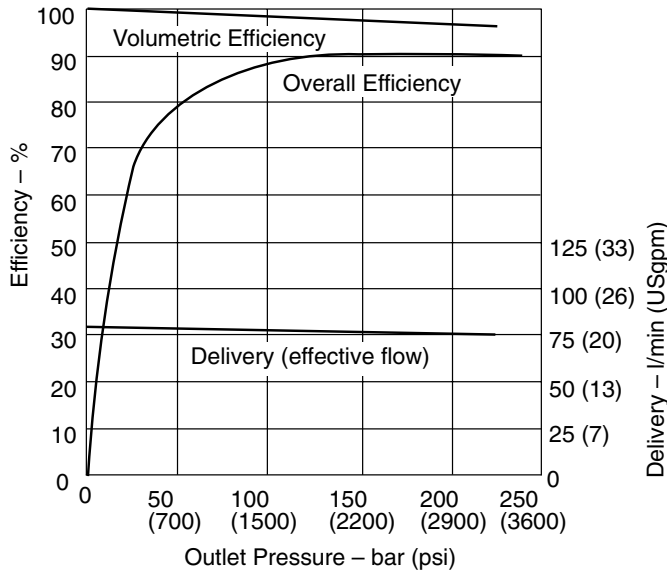

**Delivery and Efficiency at 1200 r/min, 50°C (120°F), and 1.0 bar absolute (0 psi gauge) Inlet**

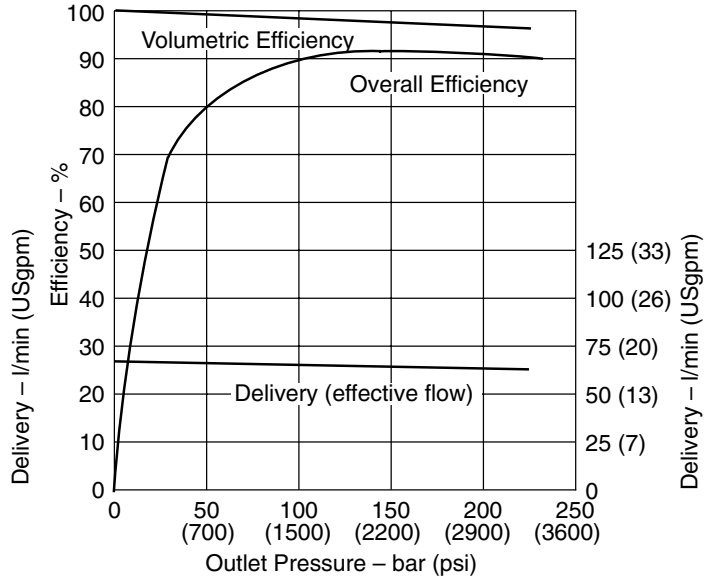

**Input Torque and Power at 1500 r/min, 50°C (120°F), and 1.0 bar absolute (0 psi gauge) Inlet**

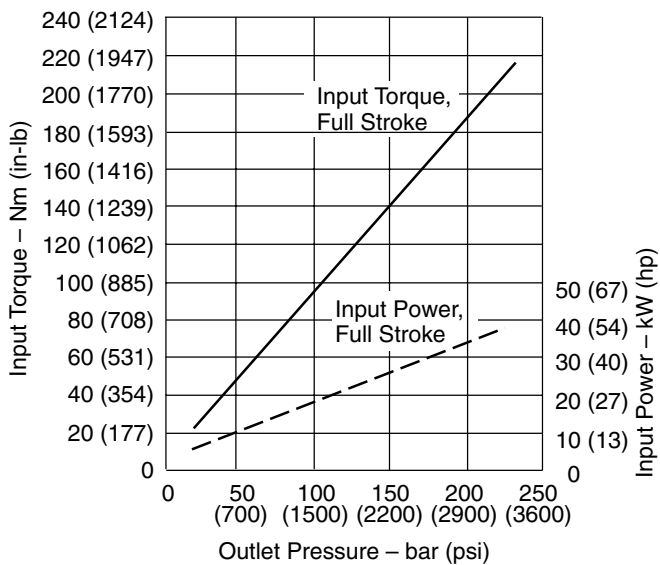

**Input Torque and Power at 1200 r/min, 50°C (120°F), and 1.0 bar absolute (0 psi gauge) Inlet**

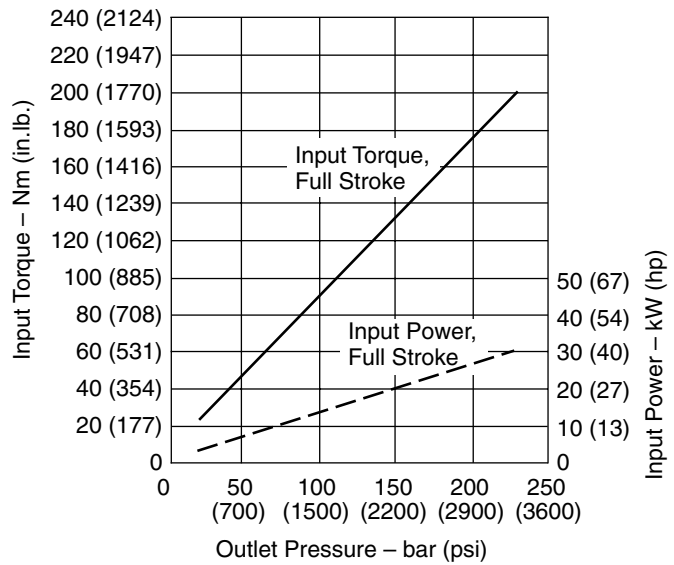

# Performance

Industrial PVM050

**Delivery and Efficiency at 1000 r/min, 50°C (120°F), and 1.0 bar absolute (0 psi gauge) Inlet**

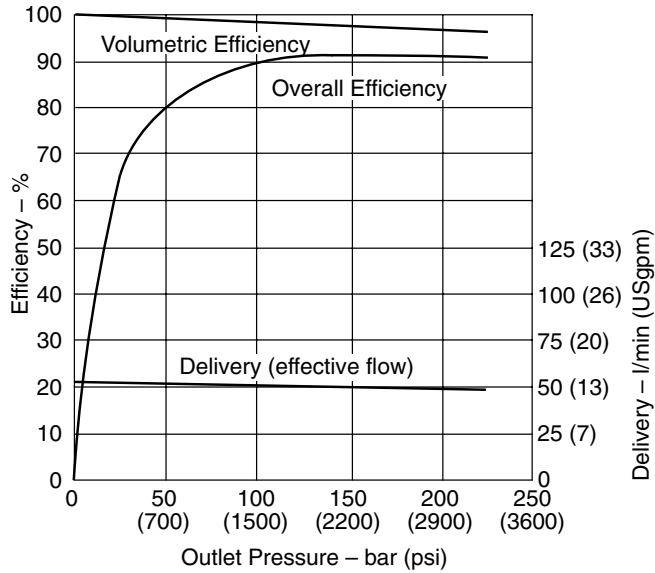

**Case Flow versus Outlet Pressure at 1800 r/min, Full Flow, 50°C (120°F), and 1.0 bar absolute (0 psi gauge) Inlet**

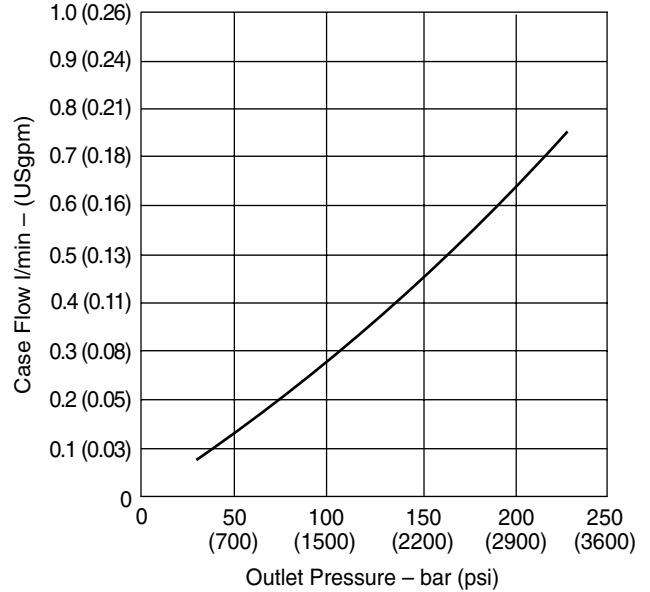

**Input Torque and Power at 1000 r/min, 50°C (120°F), and 1.0 bar absolute (0 psi gauge) Inlet**

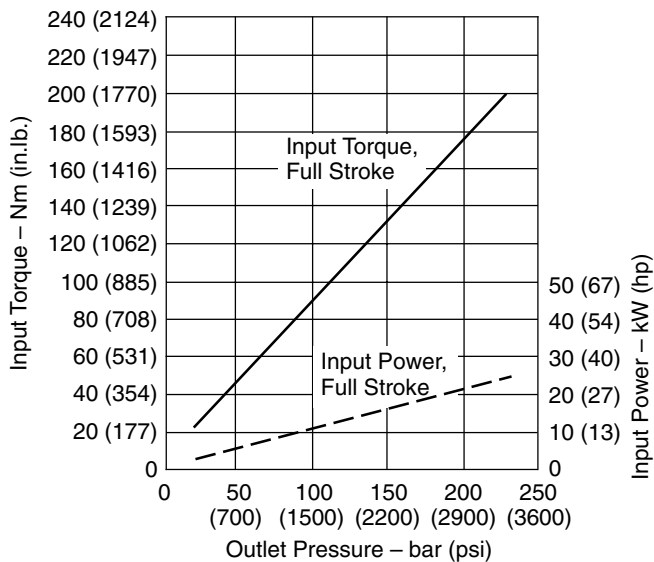

**Case Flow versus Outlet Pressure at Cutoff, 1800 r/min, 50°C (120°F), and 1.0 bar absolute (0 psi gauge) Inlet**

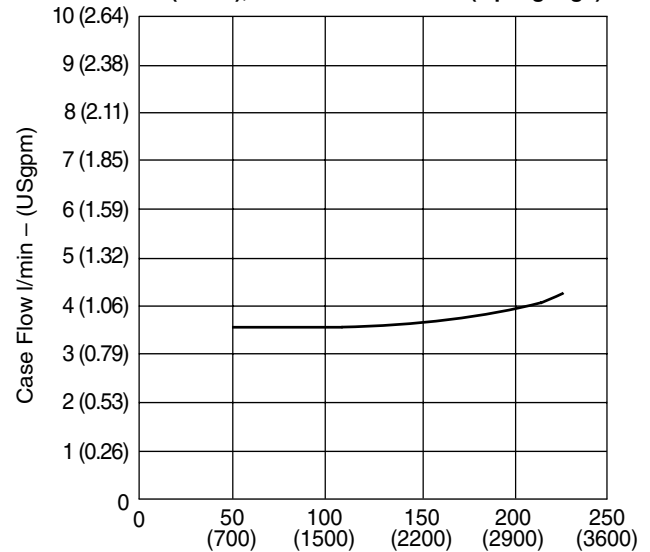



# Performance

Mobile PVM050

**Typical Noise Levels at 2600 & 600 r/min with Petroleum Oil (10W) at 93°C (200°F) and 1.0 bar absolute (0 psi gauge) inlet**

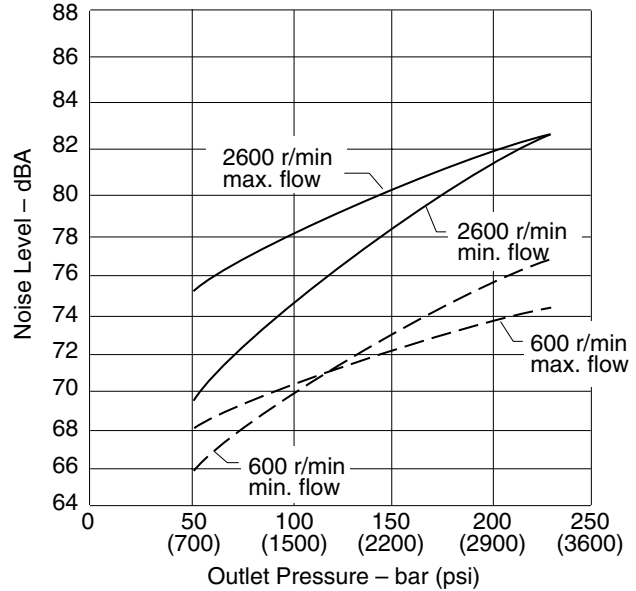

Sound pressure data equivalent to NFPA.

**Overall Efficiency versus Speed at 93°C (200°F) and 1.0 bar absolute (0 psi gauge) inlet**

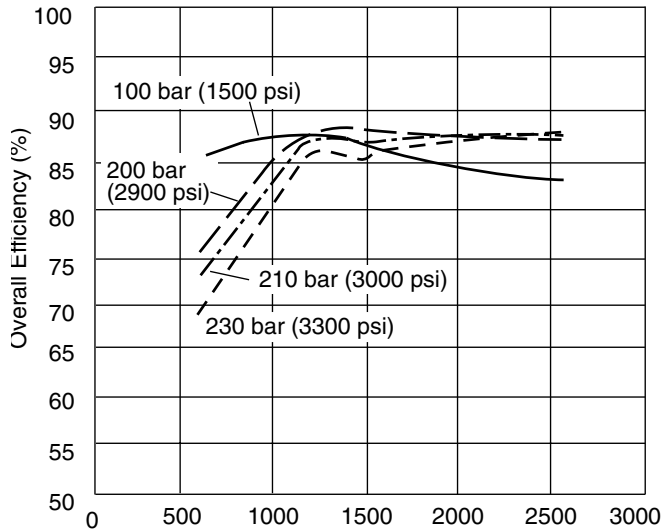

**Delivery and Case Flow versus Speed at 93°C (200°F), Full Flow and 1.0 bar absolute (0 psi gauge) inlet**

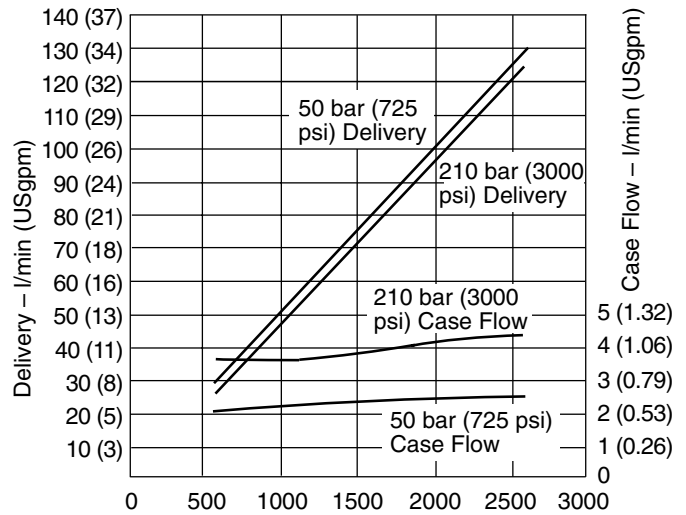

# Performance

Mobile PVM050

**Input Torque versus Speed at 93°C (200°F), Full Flow and 1.0 bar absolute (0 psi gauge) Inlet**

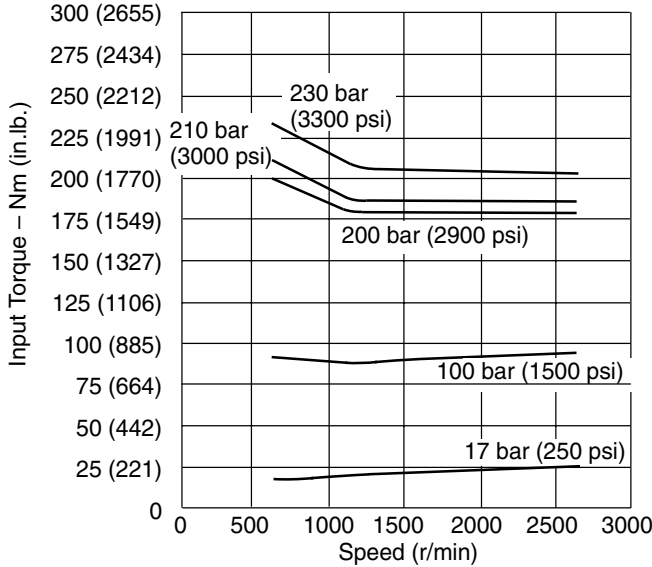

**Input Power versus Speed at 93°C (200°F), Full Flow and 1.0 bar absolute (0 psi gauge) Inlet**

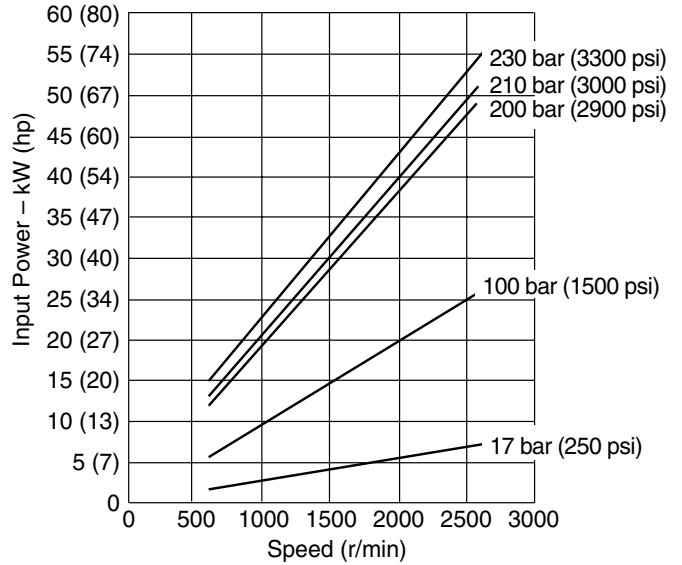

**Input Torque and Case Flow versus Speed at 93°C (200°F), Load Sense Standby and 1.0 bar absolute (0 psi gauge) Inlet**

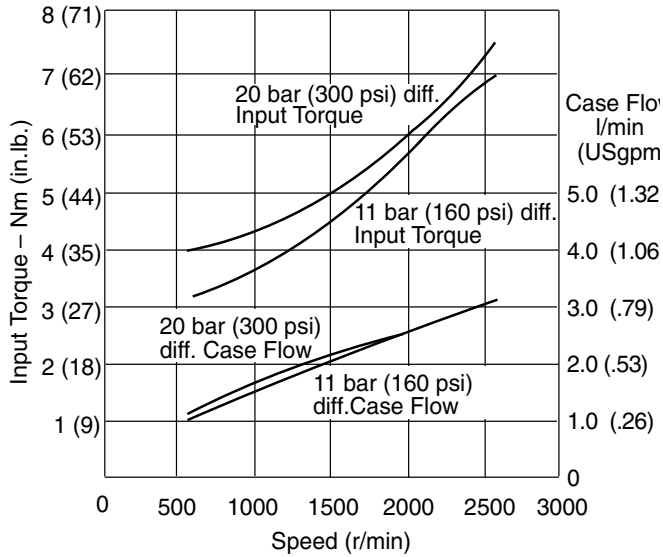

**Input Torque and Case Flow versus Speed at 93°C (200°F), Pressure Limit Cut-off and 1.0 bar absolute (0 psi gauge) Inlet**

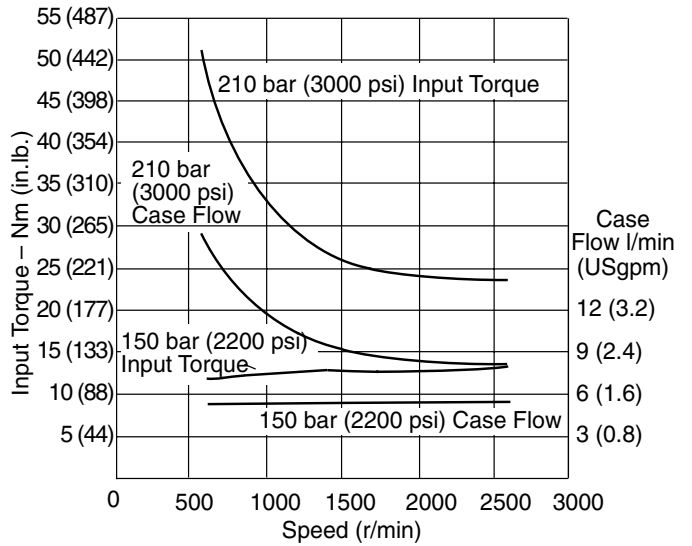

# Performance

Industrial PVM057

**Typical Noise Levels at 1800 and 1200 r/min**  
with Petroleum Oil (10W) at 50°C (120°F)  
and 1.0 bar absolute (0 psi gauge) Inlet

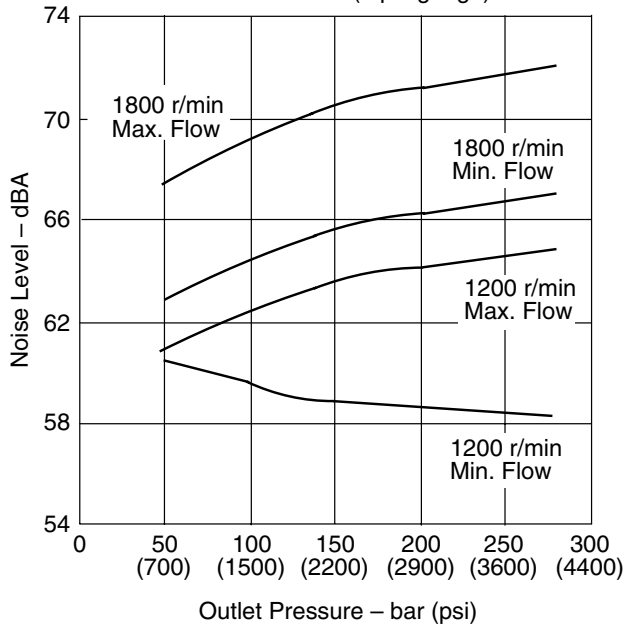

(Sound pressure data equivalent to NFPA)

**Delivery and Efficiency at 1800 r/min**

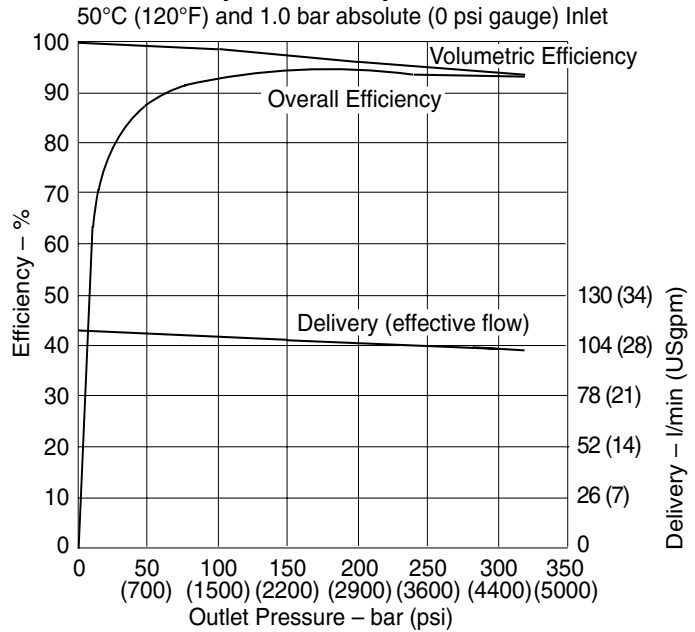

**Typical Noise Levels at 1500 and 1000 r/min**  
with Petroleum Oil (10W) at 50°C (120°F)  
and 1.0 bar absolute (0 psi gauge) Inlet

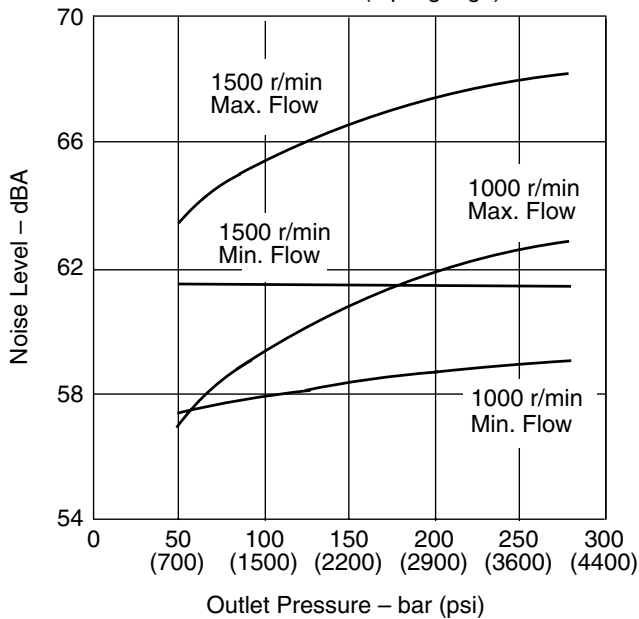

**Input Torque and Power at 1800 r/min**  
50°C (120°F) and 1.0 bar absolute (0 psi gauge) Inlet

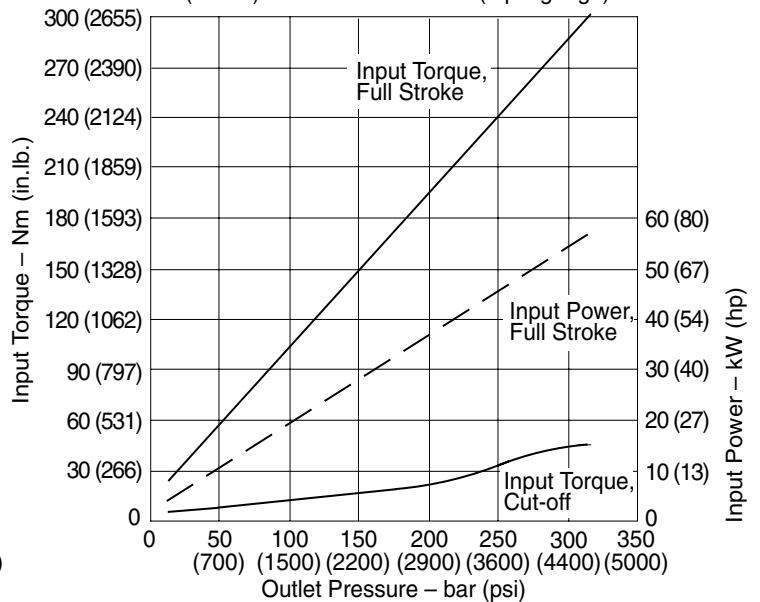

# Performance

Industrial PVM057

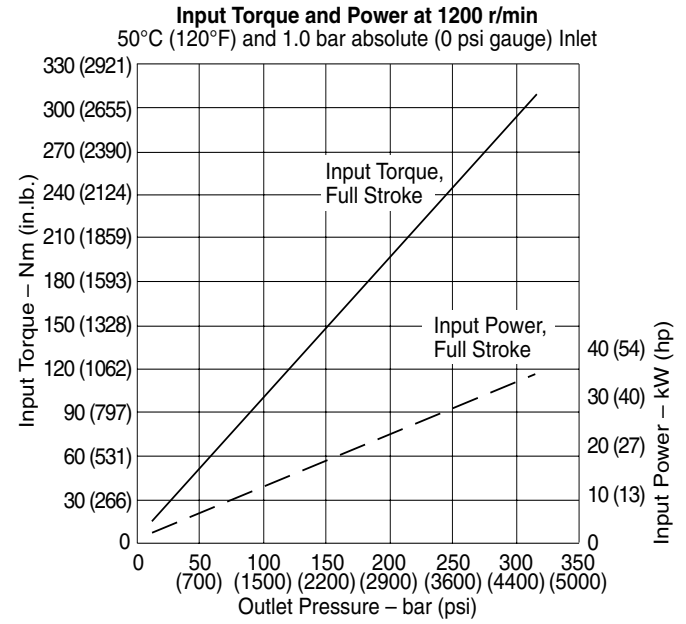
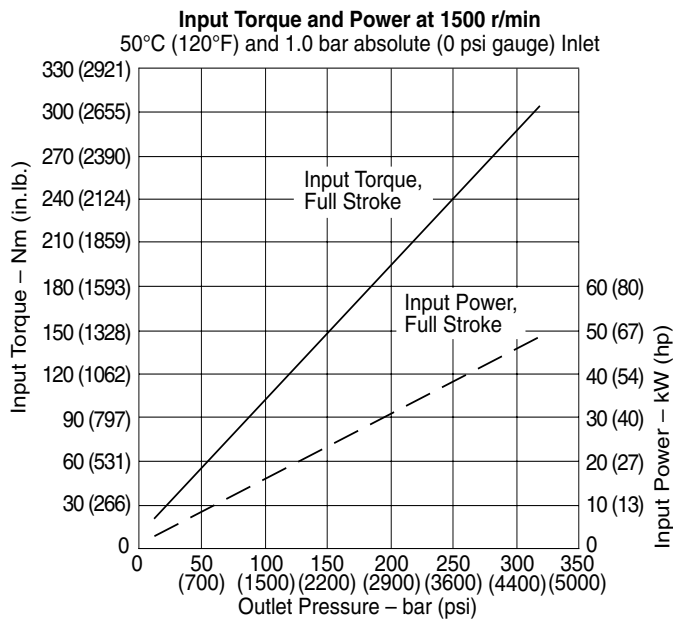
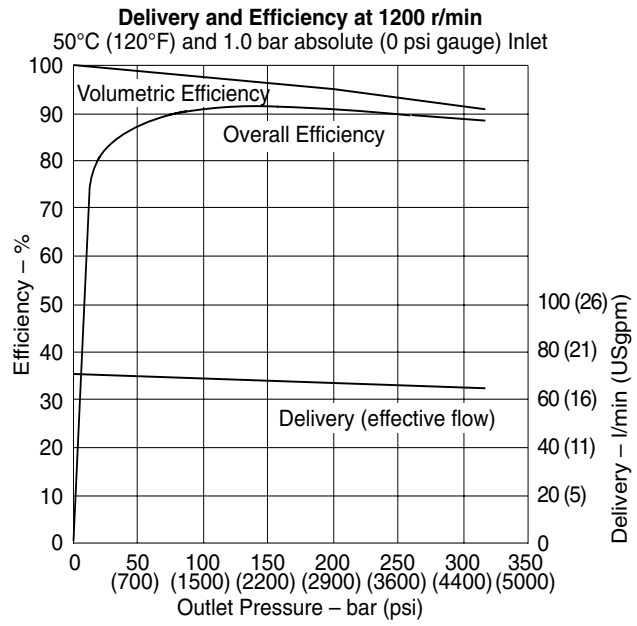
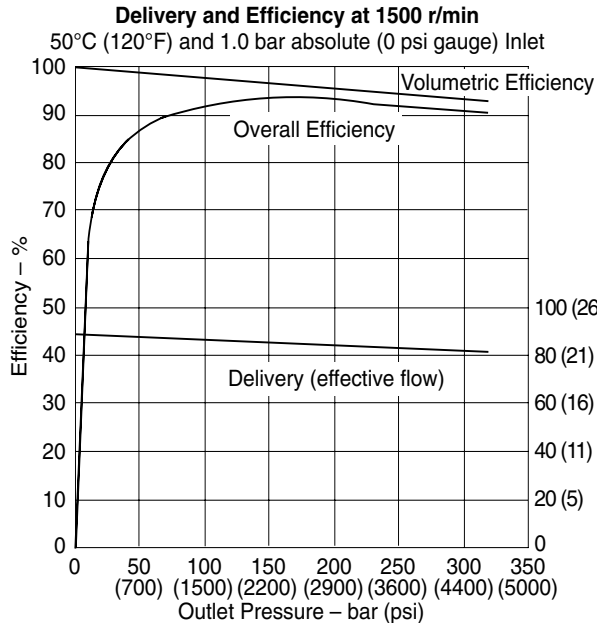

# Performance

Industrial PVM057

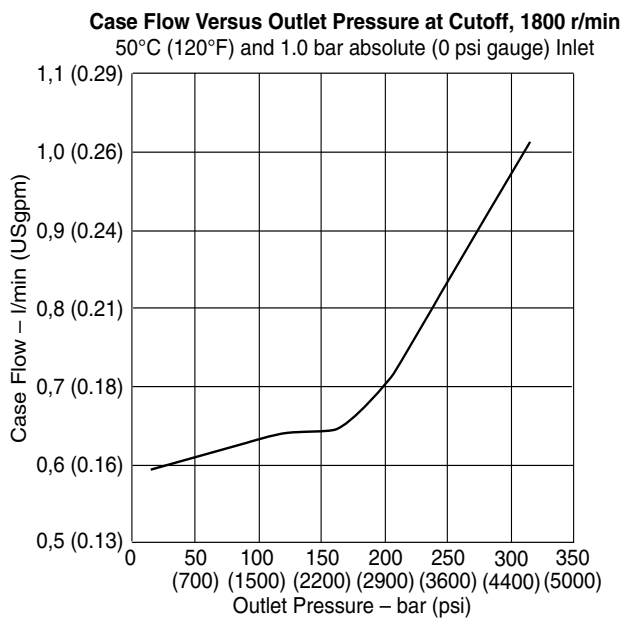
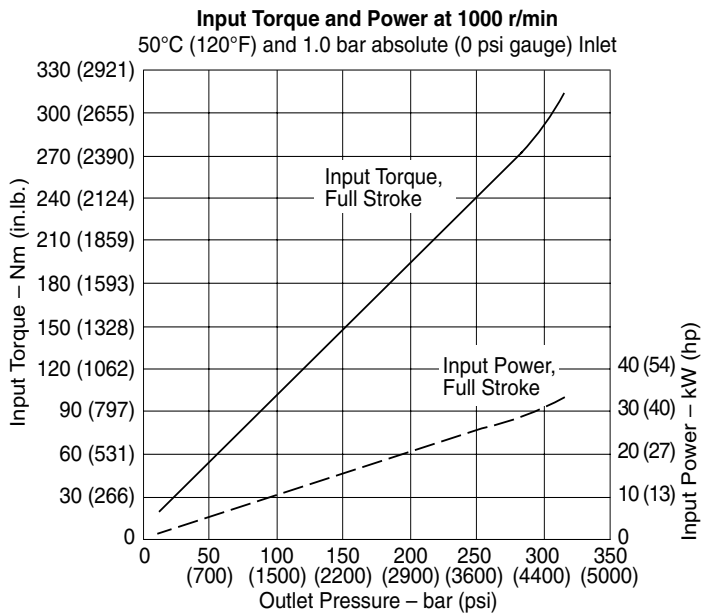
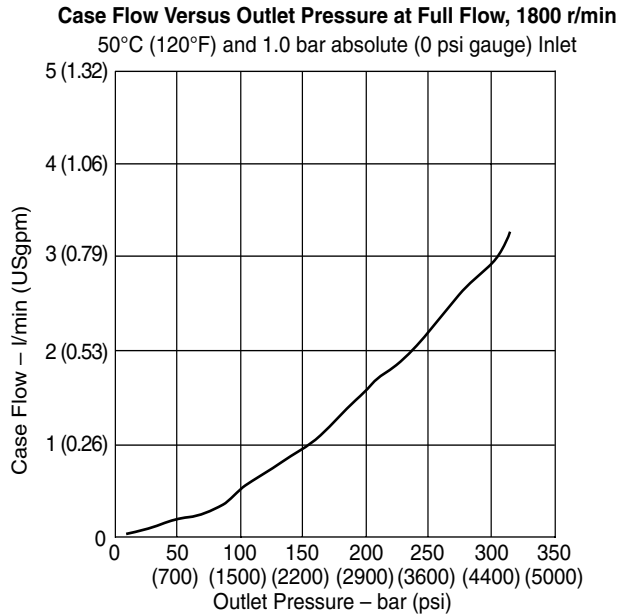
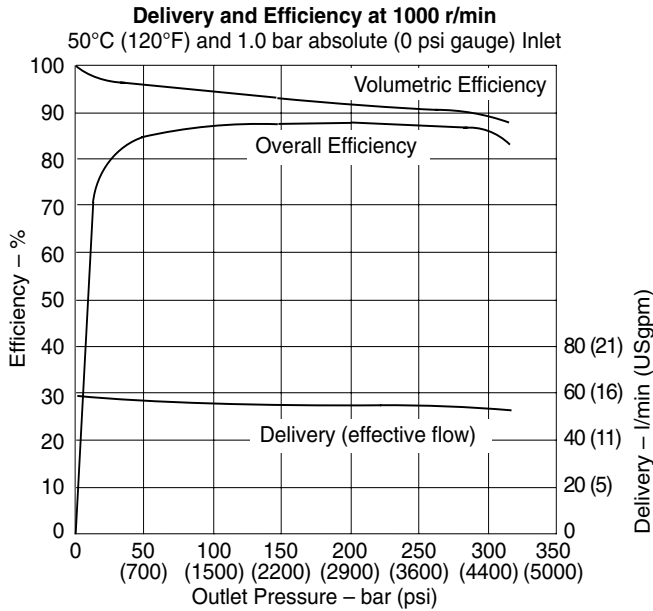

# Performance

Mobile PVM057

## Typical Noise Levels

Petroleum Oil (10W) at 93°C (200°F),  
1.0 bar absolute (0 psi gauge) Inlet

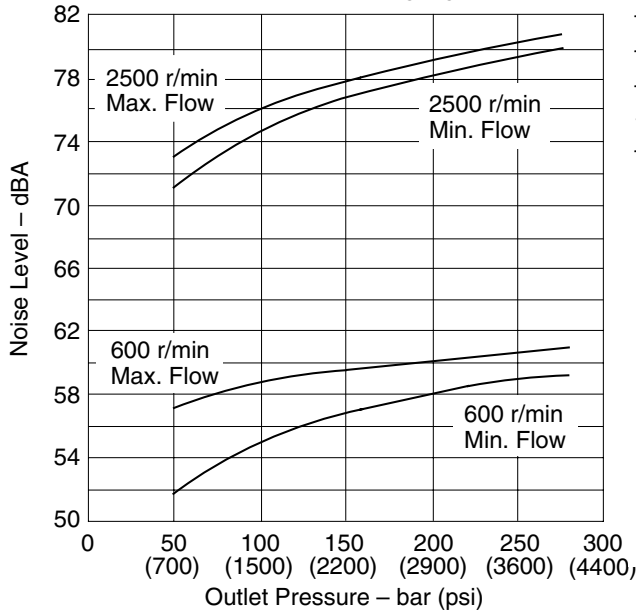

(Sound pressure data equivalent to NFPA)

## Delivery and Case Flow Versus Speed

@ 93°C (200°F), full flow and 1.0 bar absolute (0 psi) gauge Inlet

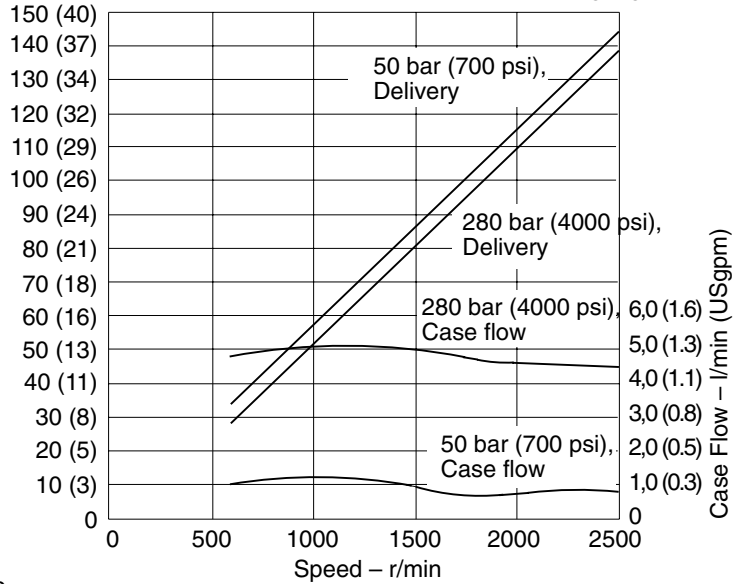

## Overall Efficiency Versus Speed

at 93°C (200°F) and 1.0 bar absolute (0 psi) gauge Inlet

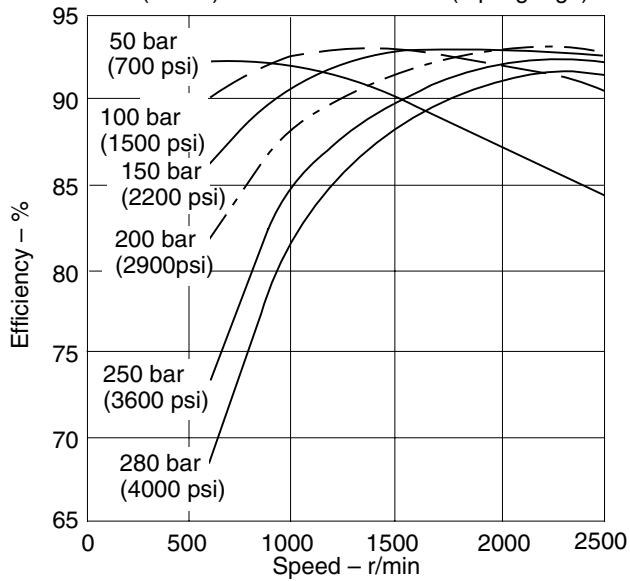

## Input Torque Versus Speed

@ 93°C (200°F), full flow and 1.0 bar absolute (0 psi) gauge inlet

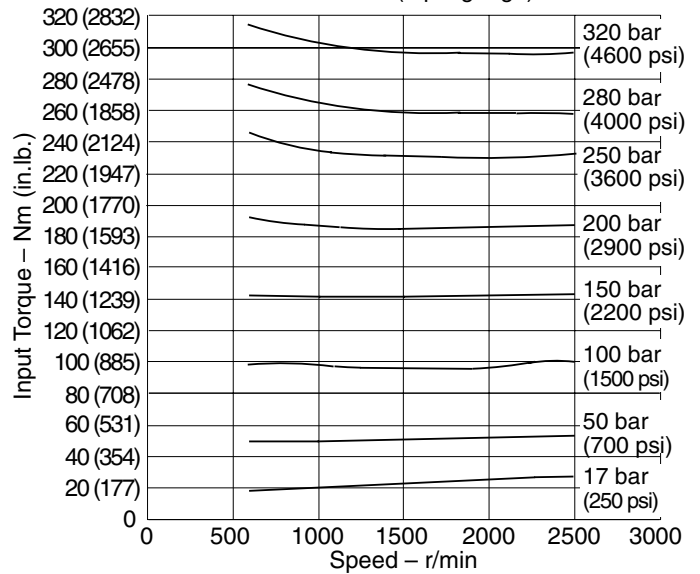

# Performance

Mobile PVM057

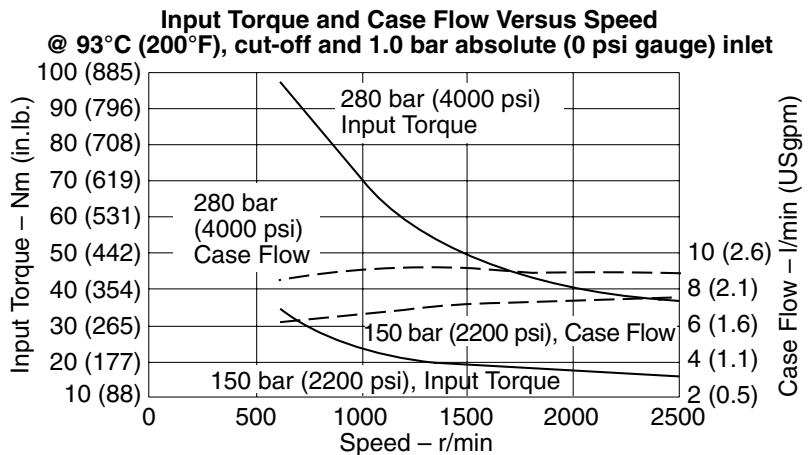
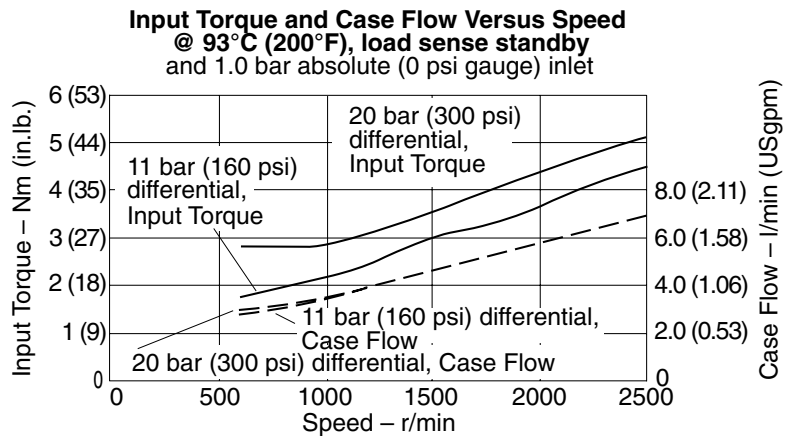
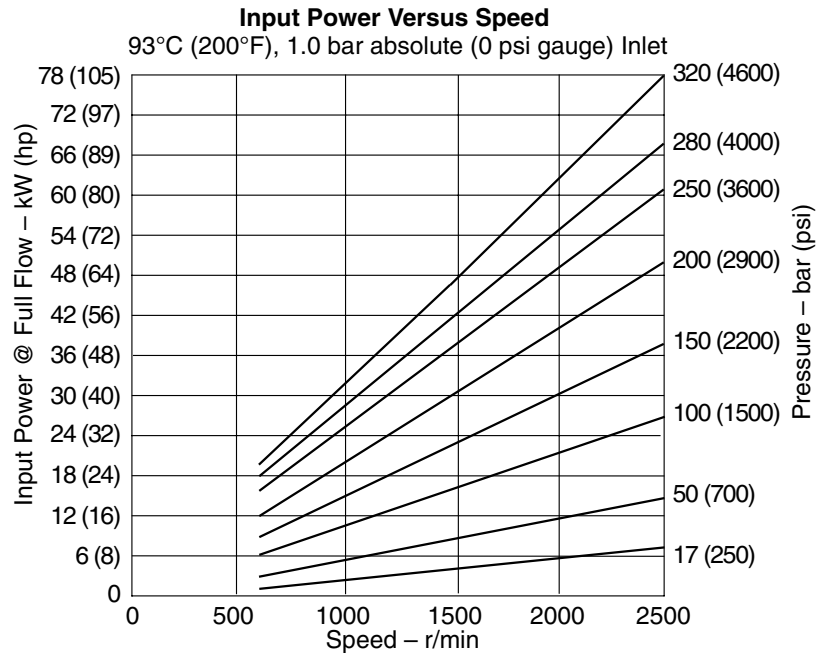

# Performance

Industrial PVM063

**Typical Noise Levels at 1800 and 1200 r/min. with Petroleum Oil (10W) at 50°C (120°F) and 1.0 bar absolute (0 psi gauge) Inlet**

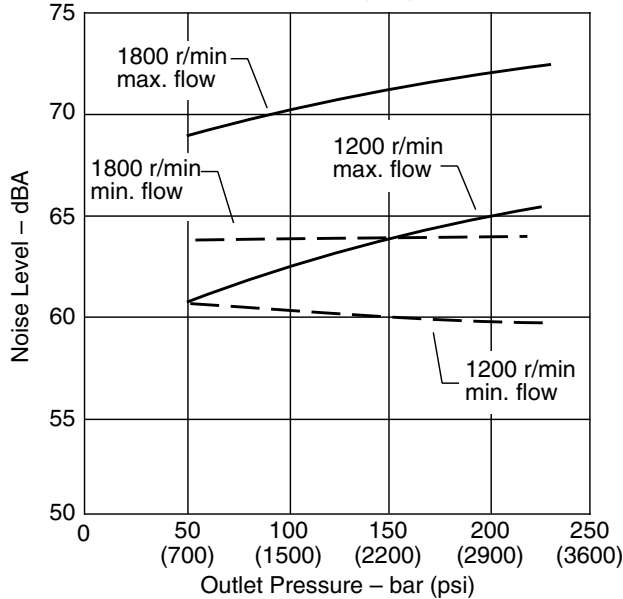

**Delivery and Efficiency at 1800 r/min, 50°C (120°F), and 1.0 bar absolute (0 psi gauge) Inlet**

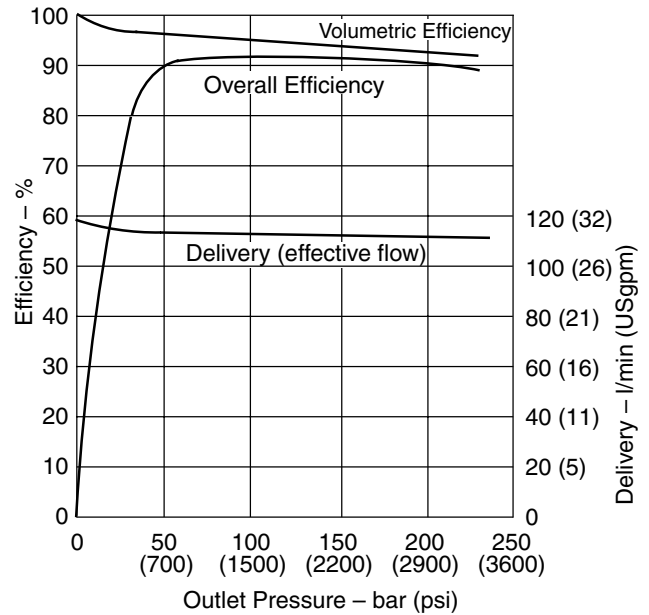

**Typical Noise Levels at 1500 and 1000 r/min. with Petroleum Oil (10W) at 50°C (120°F) and 1.0 bar absolute (0 psi gauge) Inlet**

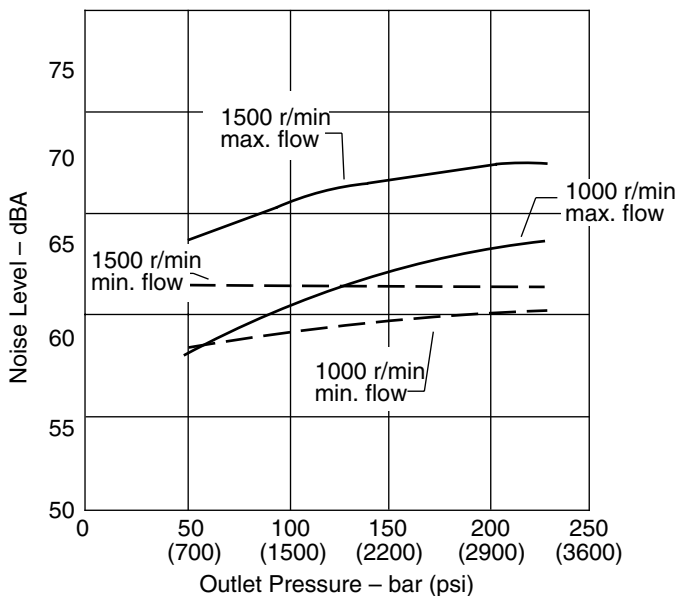

**Input Torque and Power at 1800 r/min, 50°C (120°F), and 1.0 bar absolute (0 psi gauge) Inlet**

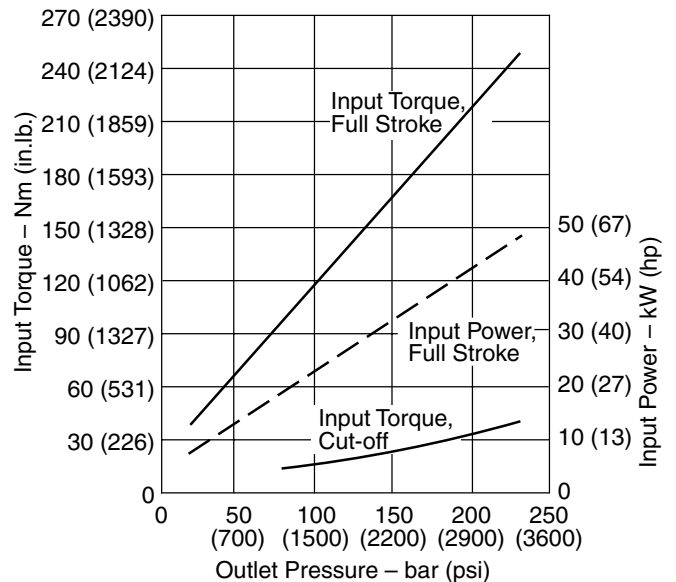

Sound pressure data equivalent to NFPA.



# Performance

Industrial PVM063

**Delivery and Efficiency at 1500 r/min, 50 °C (120 °F), and 1.0 bar absolute (0 psi gauge) Inlet**

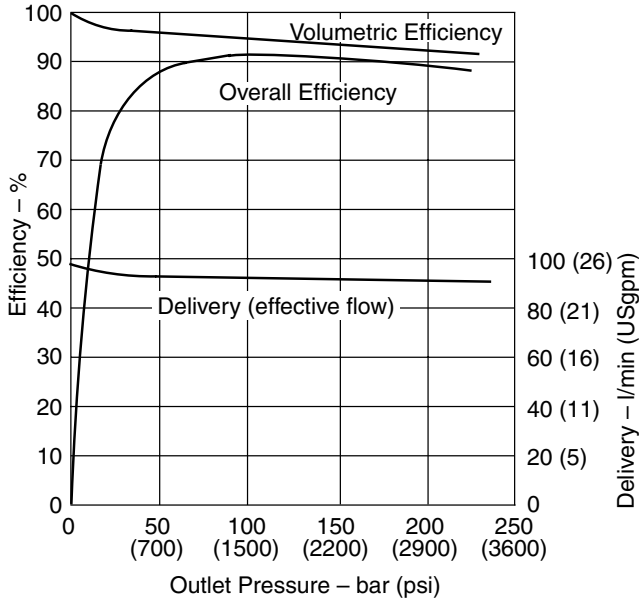

**Delivery and Efficiency at 1200 r/min, 50 °C (120 °F), and 1.0 bar absolute (0 psi gauge) Inlet**

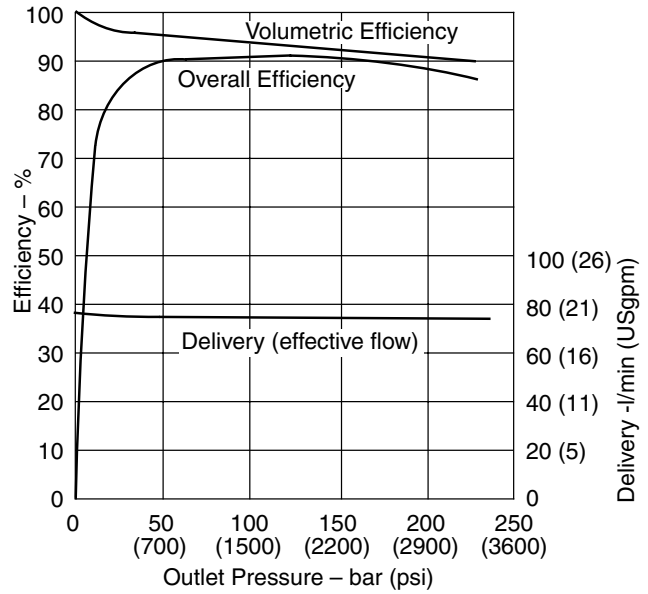

**Input Torque and Power at 1500 r/min, 50 °C (120 °F), and 1.0 bar absolute (0 psi gauge) Inlet**

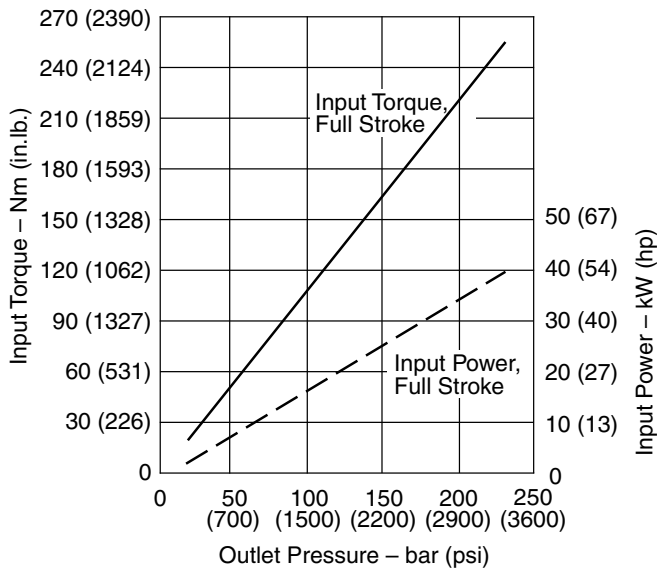

**Input Torque and Power at 1200 r/min, 50 °C (120 °F), and 1.0 bar absolute (0 psi gauge) Inlet**

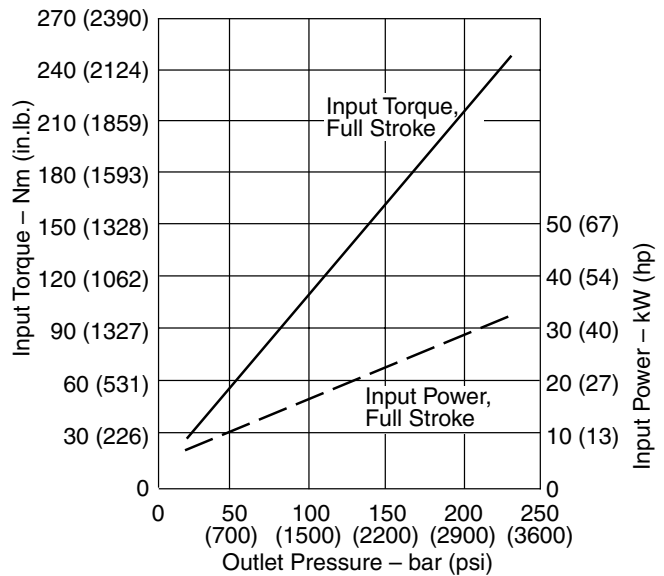

# Performance

Industrial PVM063

**Delivery and Efficiency at 1000 r/min, 50°C (120°F), and 1.0 bar absolute (0 psi gauge) Inlet**

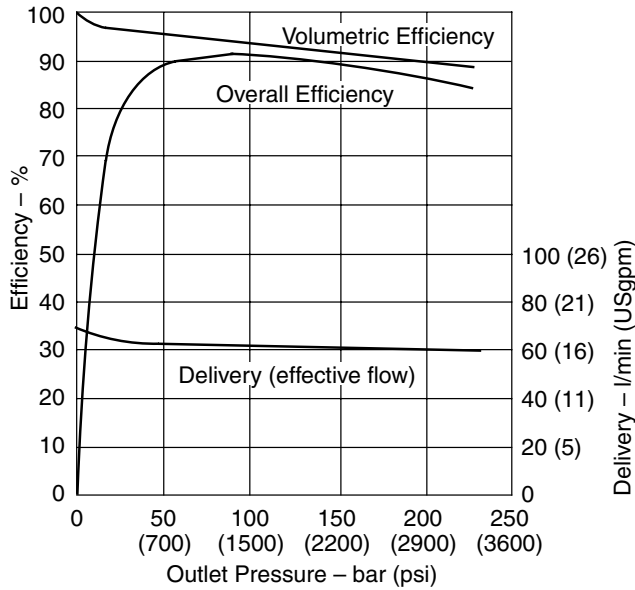

**Case Flow versus Outlet Pressure at 1800 r/min, Full Flow, 50°C (120°F), and 1.0 bar absolute (0 psi gauge) Inlet**

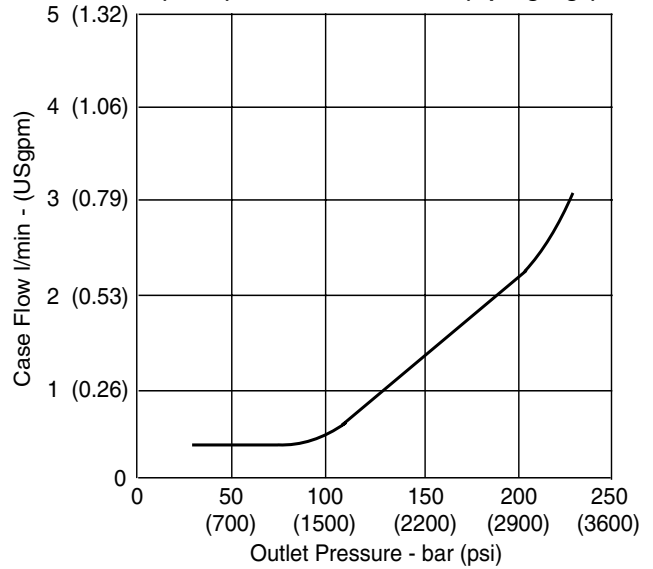

**Input Torque and Power at 1000 r/min, 50°C (120°F), and 1.0 bar absolute (0 psi gauge) Inlet**

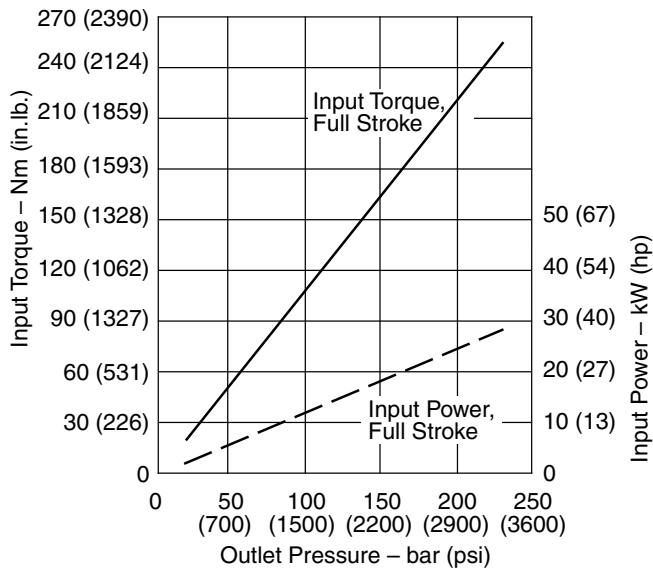

**Case Flow versus Outlet Pressure at Cutoff, 1800 r/min, 50°C (120°F), and 1.0 bar absolute (0 psi gauge) Inlet**

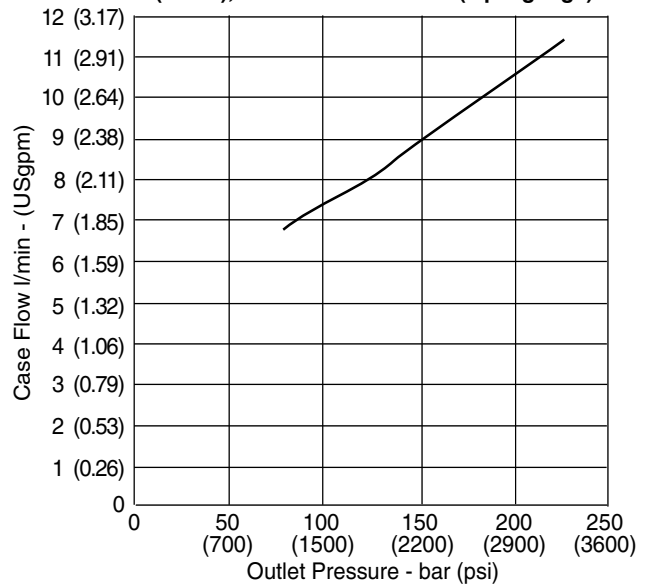

# Performance

Mobile PVM063

**Typical Noise Levels at 2500 & 600 r/min with Petroleum Oil (10W) at 93°C (200°F) and 1.0 bar absolute (0 psi gauge) Inlet**

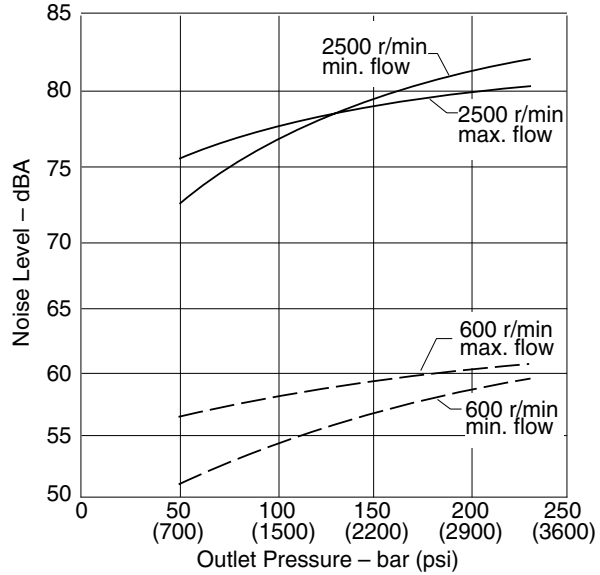

Sound pressure data equivalent to NFPA.

**Overall Efficiency versus Speed at 93°C (200°F) and 1.0 bar absolute (0 psi gauge) inlet**

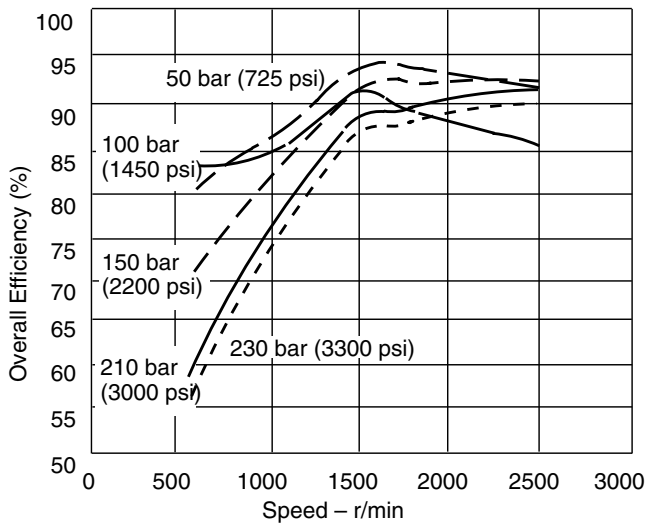

**Delivery and Case Flow versus Speed at 93°C (200°F), Full Flow 1.0 bar absolute (0 psi gauge) Inlet**

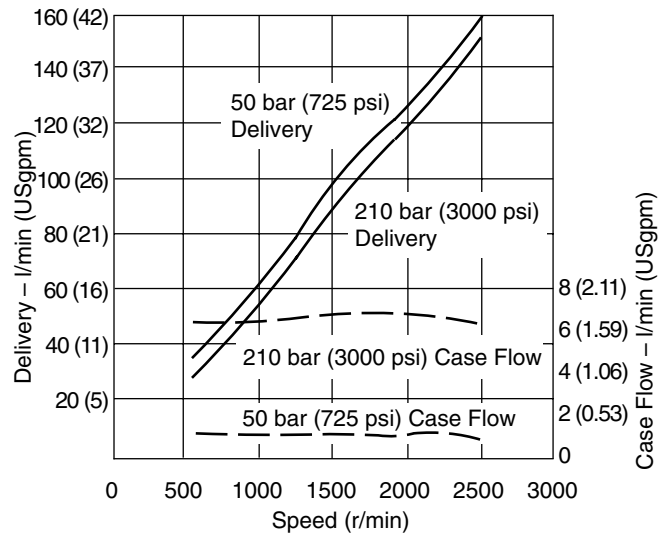

# Performance

Mobile PVM063

**Input Torque versus Speed at 93°C (200°F), Full Flow and 1.0 bar absolute (0 psi gauge) Inlet**

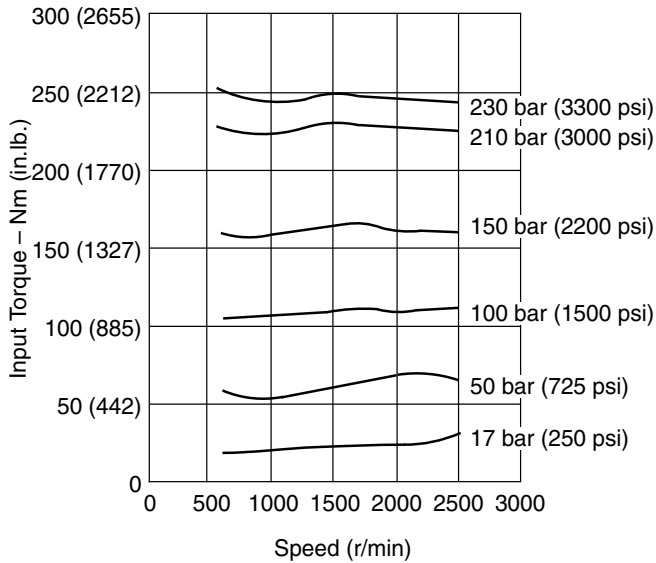

**Input Power versus Speed at 93°C (200°F), Full Flow and 1.0 bar absolute (0 psi gauge) Inlet**

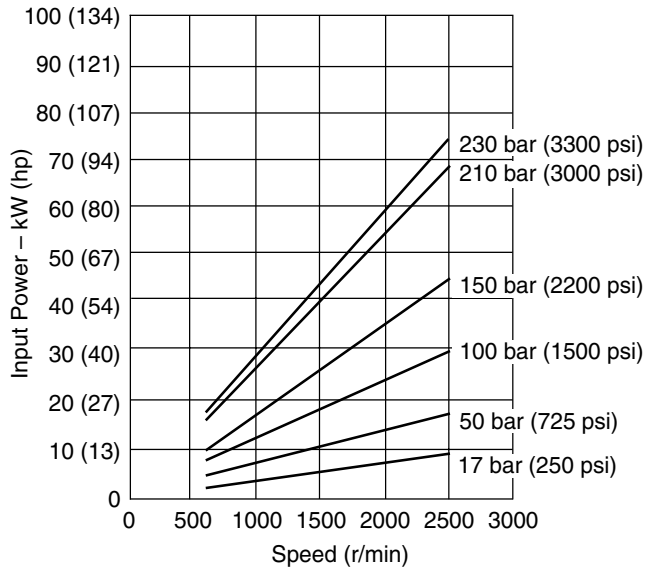

**Input Torque and Case Flow versus Speed at 93°C (200°F), Load Sense Standby and 1.0 bar absolute (0 psi gauge) Inlet**

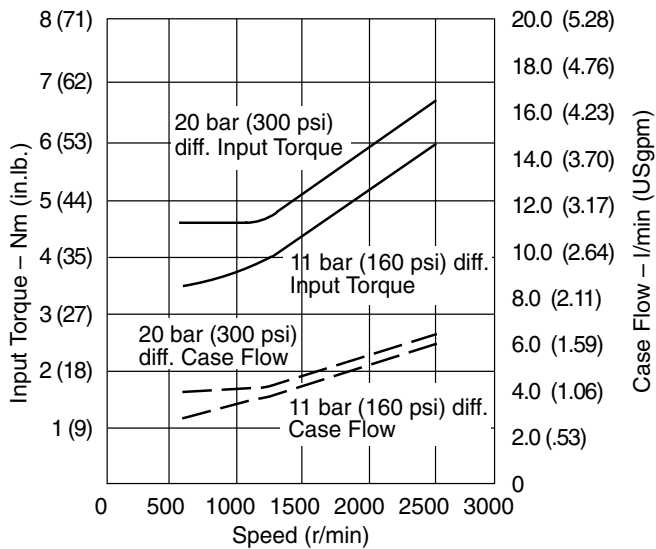

**Input Torque and Case Flow versus Speed at 93°C (200°F), Pressure Limit Cut-off and 1.0 bar absolute (0 psi gauge) Inlet**

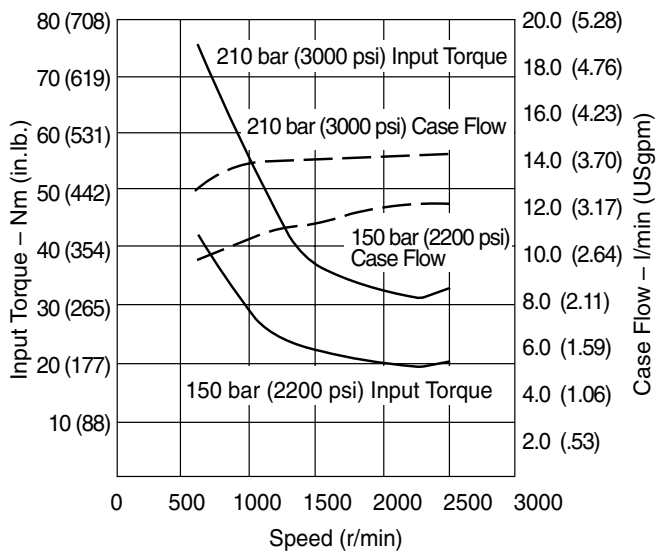

# Performance

Industrial PVM074

**Typical Noise Levels at 1800 and 1200 r/min**  
with Petroleum Oil (10W) at 50°C (120°F)  
and 1.0 bar absolute (0 psi gauge) Inlet

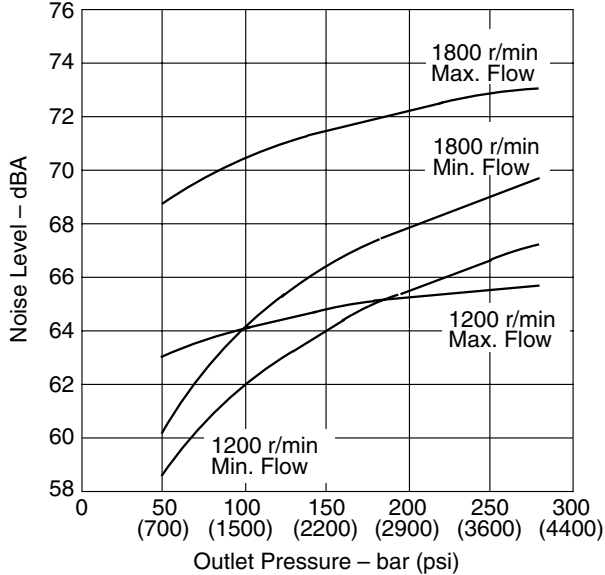

Sound pressure data  
equivalent to NFPA.

**Delivery and Efficiency at 1800 r/min**  
50°C (120°F) and 1.0 bar absolute (0 psi gauge) Inlet

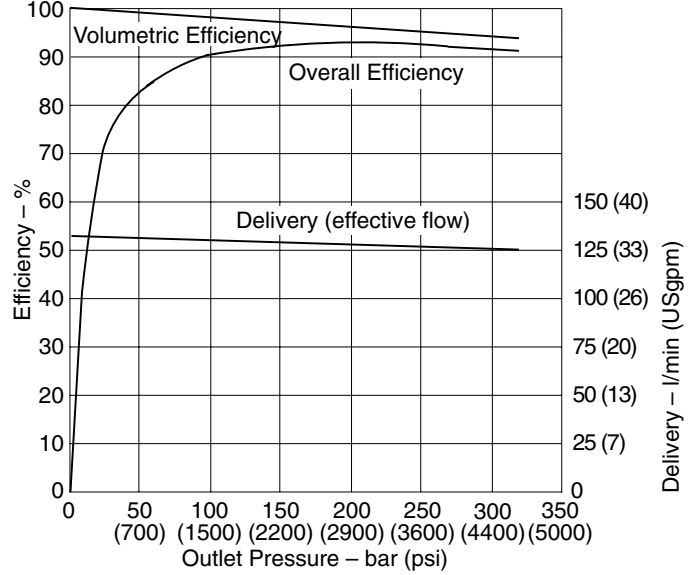

**Typical Noise Levels at 1500 and 1000 r/min**  
with Petroleum Oil (10W) at 50°C (120°F)  
and 1.0 bar absolute (0 psi gauge) Inlet

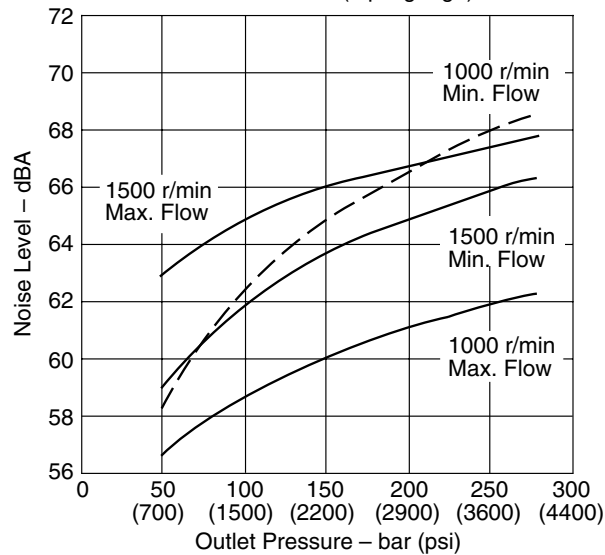

**Input Torque and Power at 1800 r/min**  
50°C (120°F) and 1.0 bar absolute (0 psi gauge) Inlet

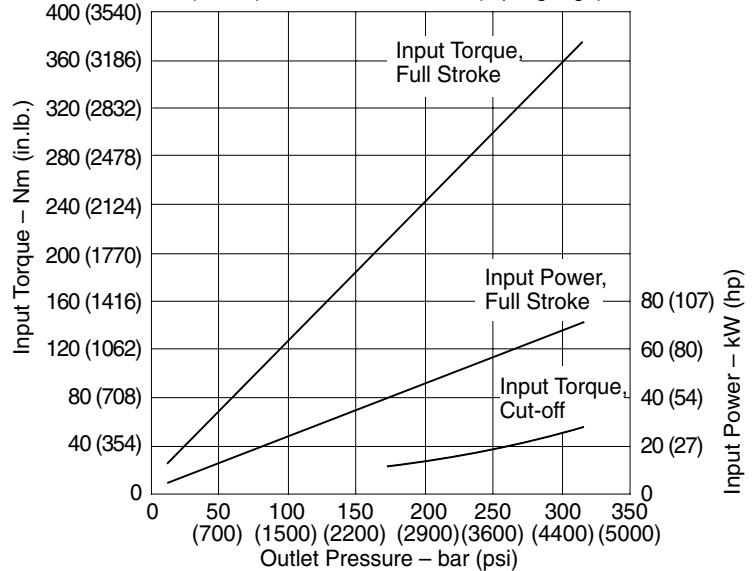

# Performance

Industrial PVM074

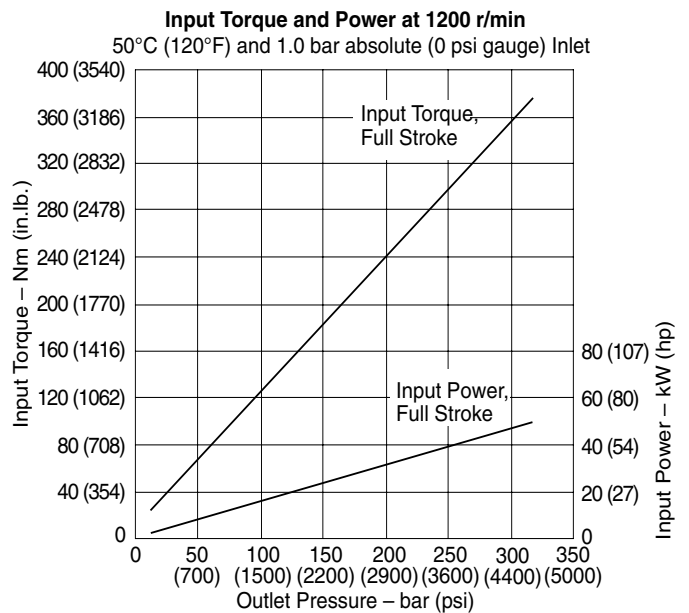
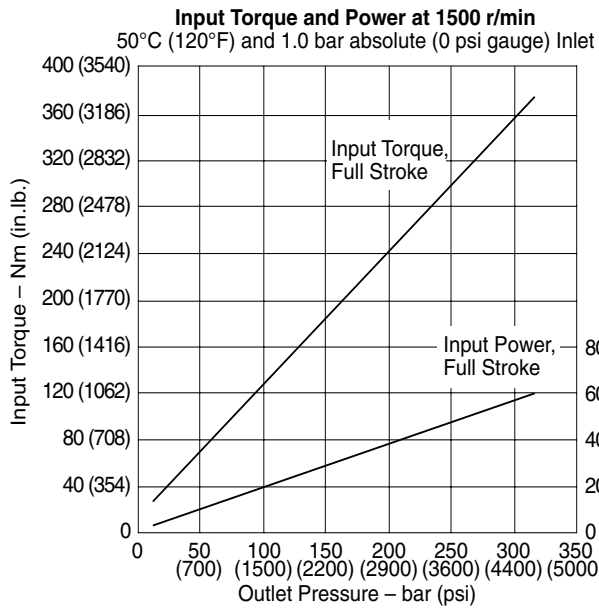
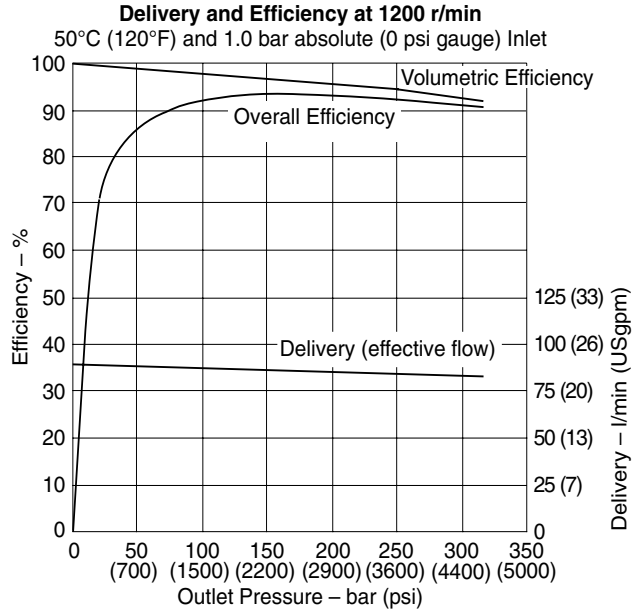
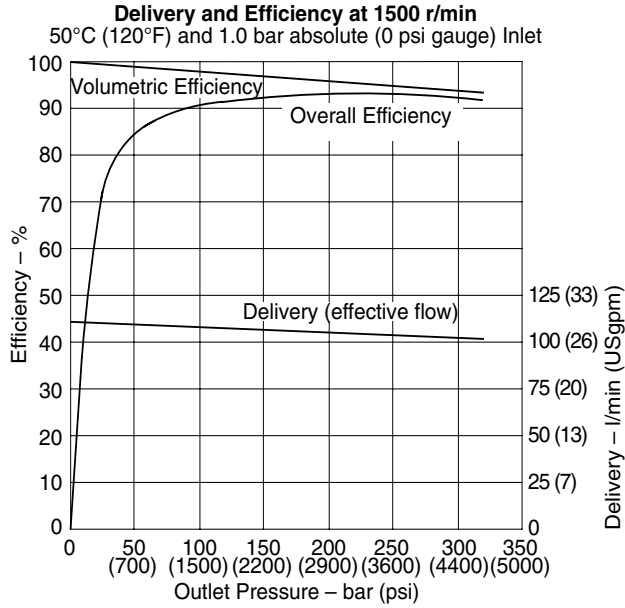

# Performance

Industrial PVM074

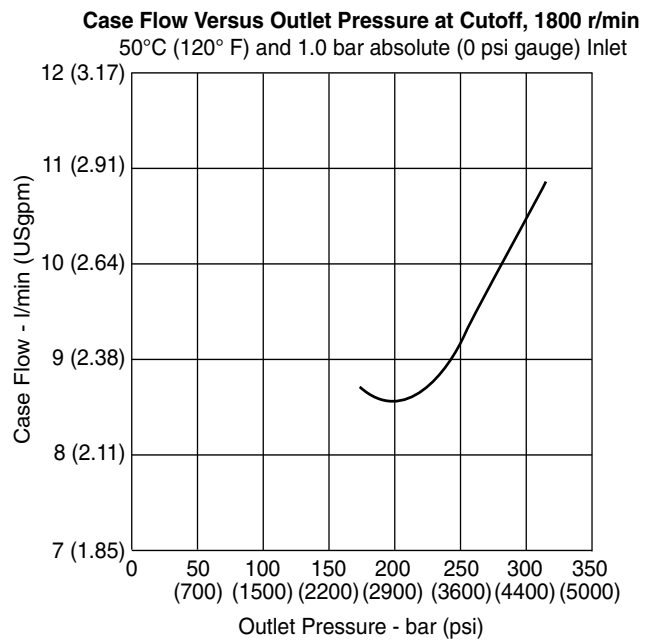
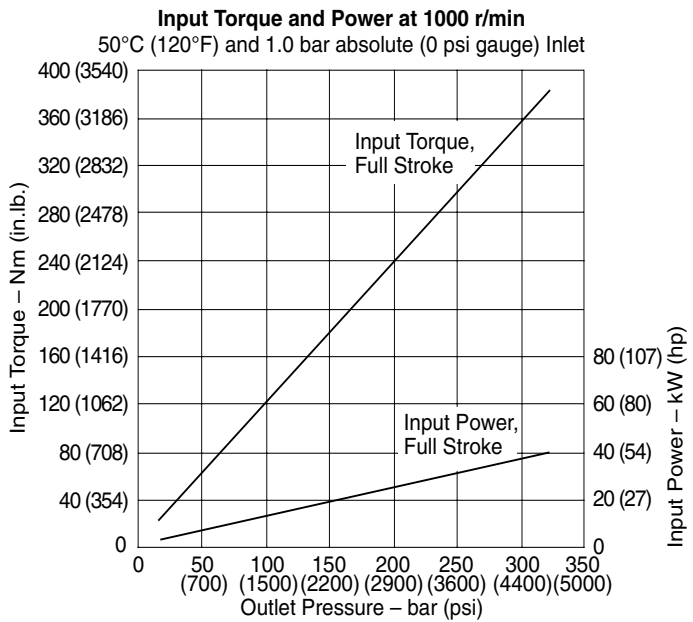
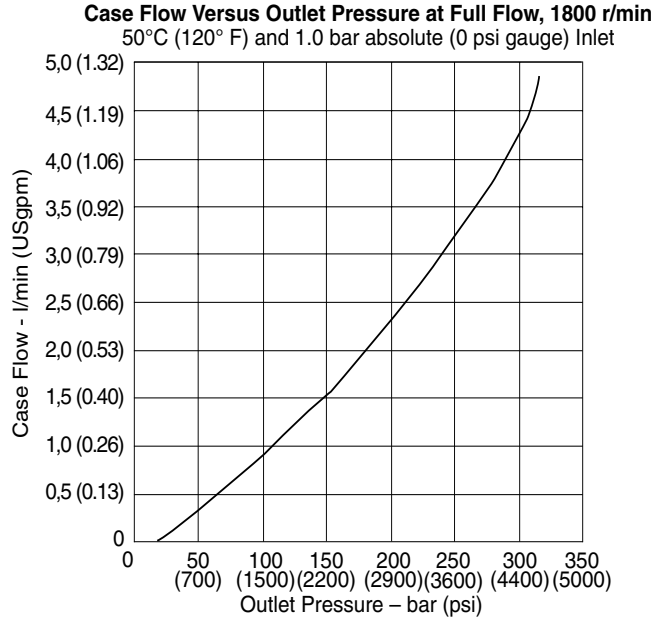
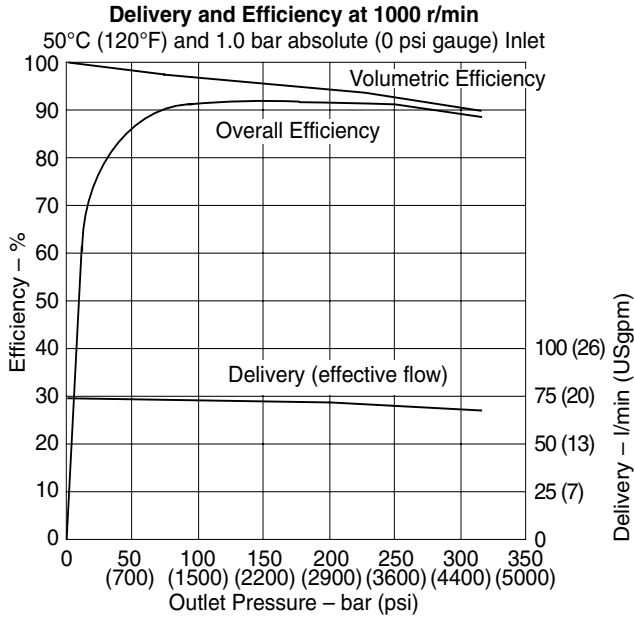

# Performance

Mobile PVM074

**Typical Noise Levels**  
 Petroleum Oil (10W) at 93°C (200°F),  
 1.0 bar absolute (0 psi gauge) Inlet  
 (Sound pressure data equivalent to NFPA)

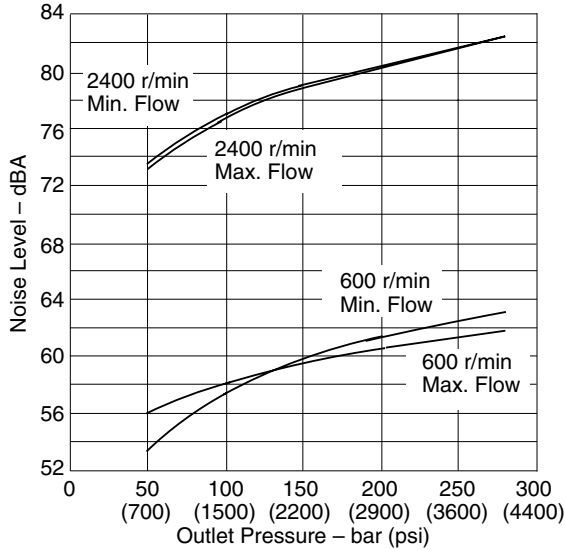

**Delivery and Case Flow Versus Speed**

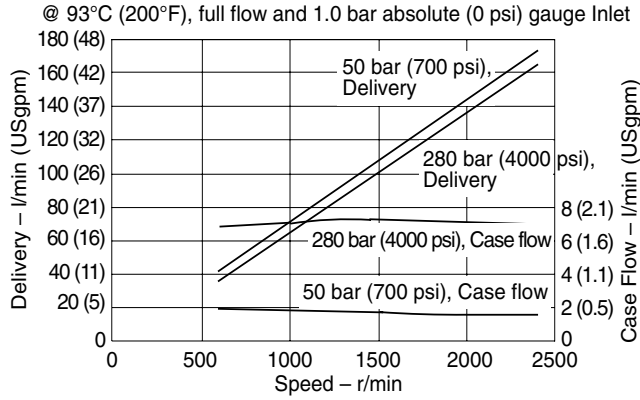

**Input Torque Versus Speed**

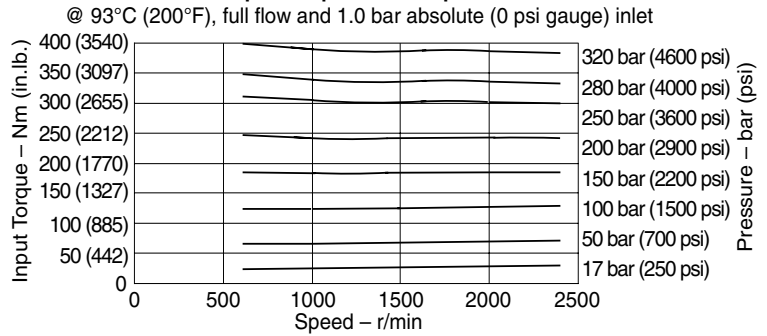

**Overall Efficiency Versus Speed**

at 93°C (200°F) and 1.0 bar absolute (0 psi gauge) Inlet

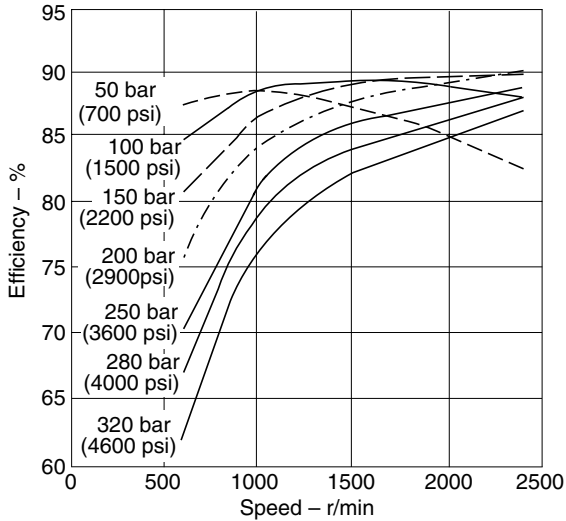

**Input Power Versus Speed**

93°C (200°F), 1.0 bar absolute (0 psi gauge) Inlet

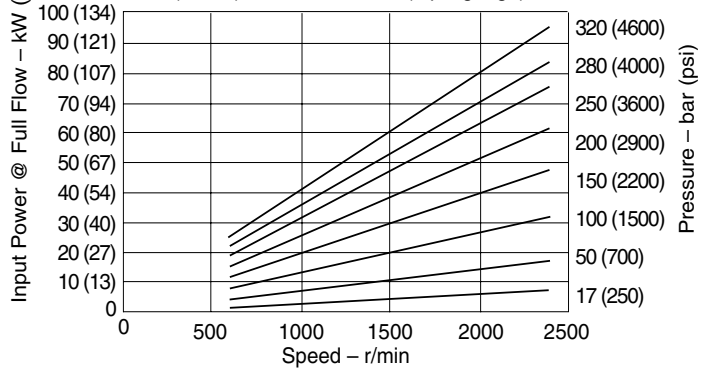



# Performance

Mobile PVM074

## Input Torque and Case Flow Versus Speed

@ 93°C (200°F), load sense standby and  
1.0 bar absolute (0 psi gauge) inlet

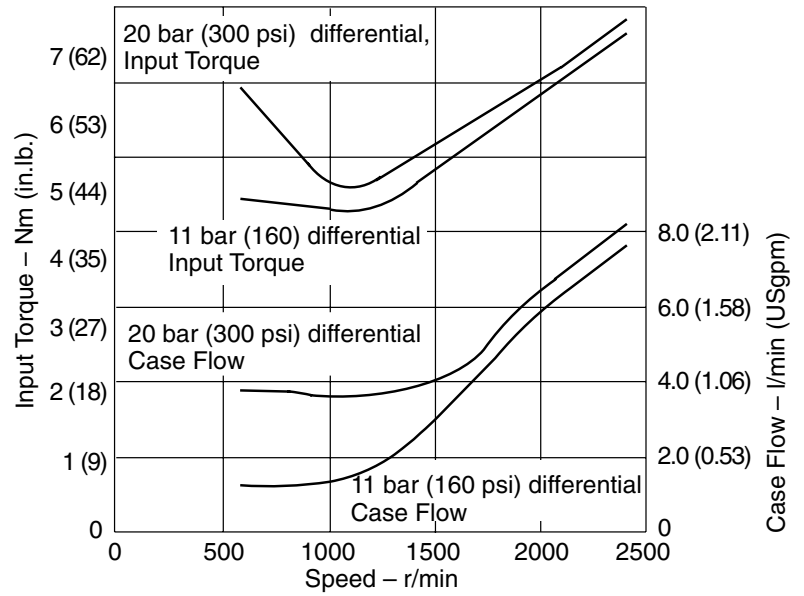

## Input Torque and Case Flow Versus Speed

@ 93°C (200°F), cut-off and  
1.0 bar absolute (0 psi gauge) inlet

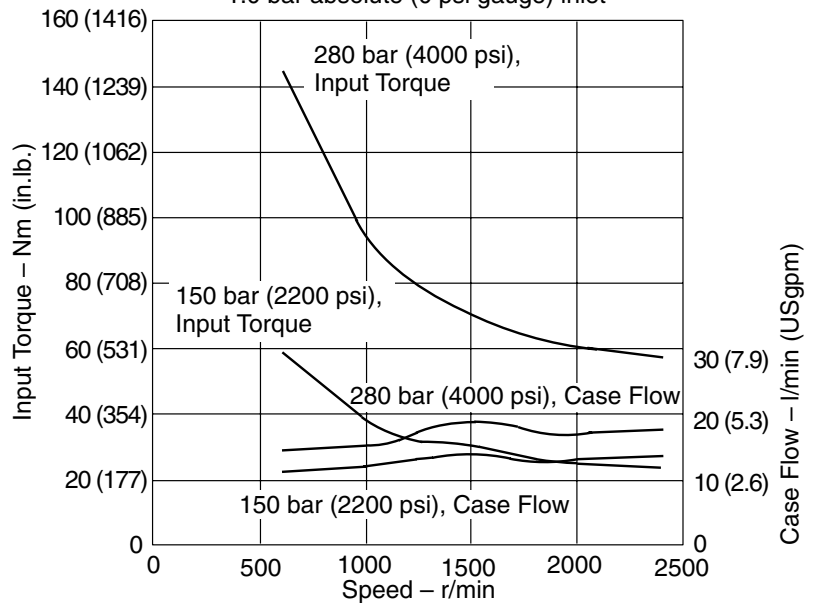

# Performance

Industrial PVM081

**Typical Noise Levels at 1800 and 1200 r/min. with Petroleum Oil (10W) at 50°C (120°F) and 1.0 bar absolute (0 psi gauge) Inlet**

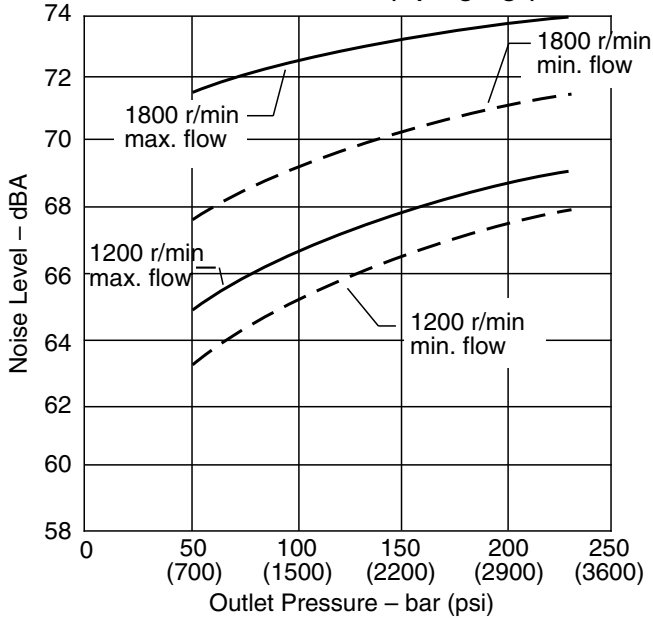

**Delivery and Efficiency at 1800 r/min, 50°C (120°F), and 1.0 bar absolute (0 psi gauge) Inlet**

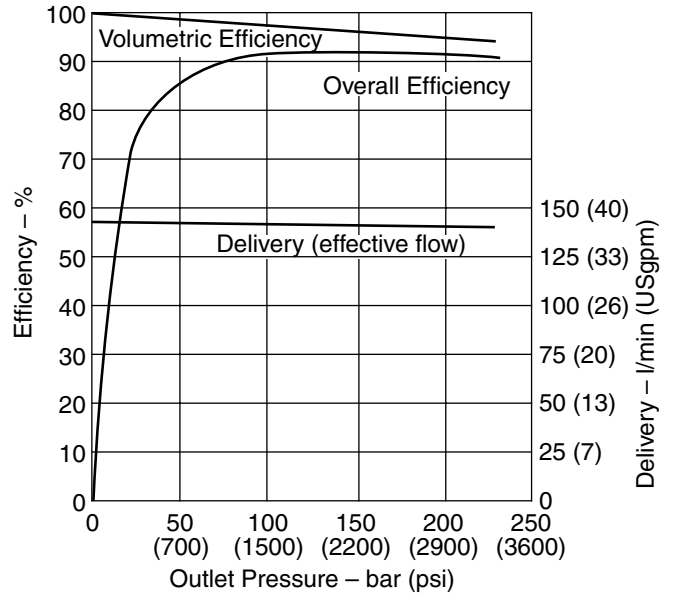

**Typical Noise Levels at 1500 and 1000 r/min. with Petroleum Oil (10W) at 50°C (120°F) and 1.0 bar absolute (0 psi gauge) Inlet**

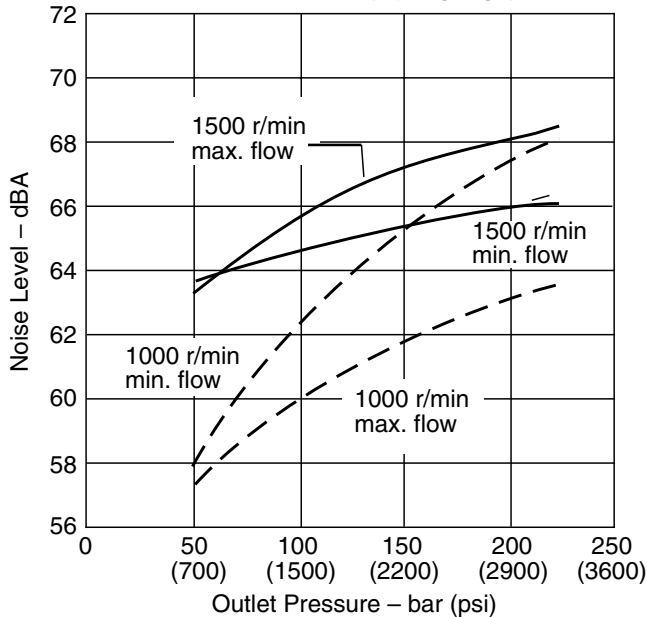

**Input Torque and Power at 1800 r/min, 50°C (120°F), and 1.0 bar absolute (0 psi gauge) Inlet**

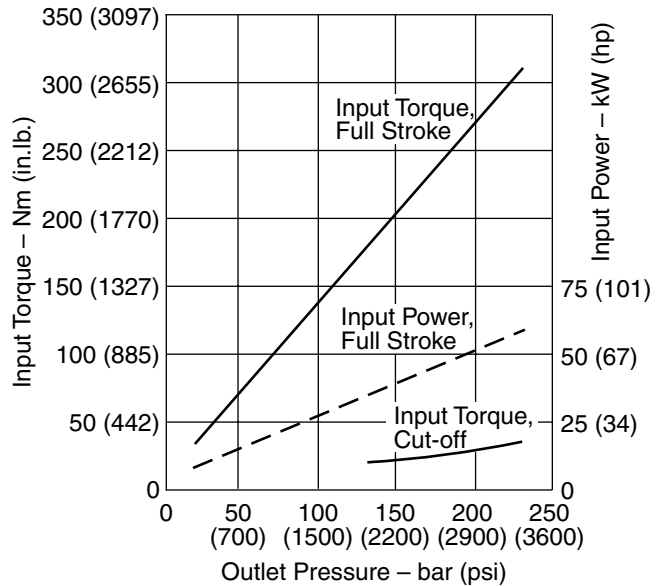

Sound pressure data equivalent to NFPA.

# Performance

Industrial PVM081

**Delivery and Efficiency at 1500 r/min, 50 °C (120 °F), and 1.0 bar absolute (0 psi gauge) Inlet**

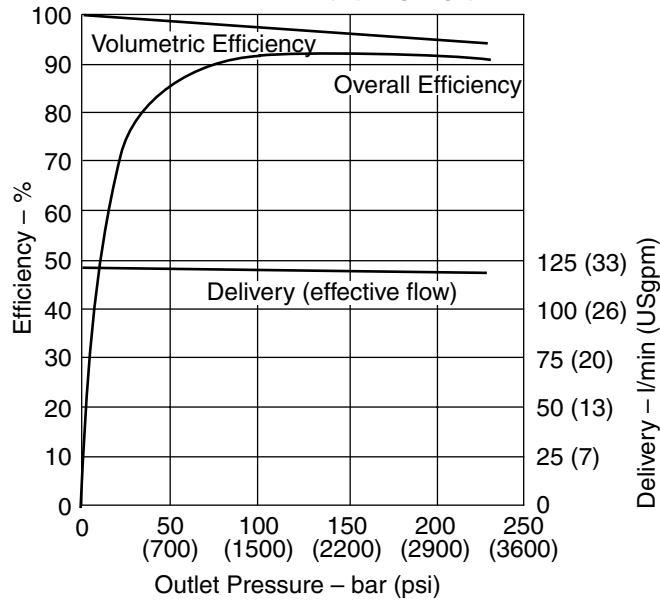

**Delivery and Efficiency at 1200 r/min, 50 °C (120 °F), and 1.0 bar absolute (0 psi gauge) Inlet**

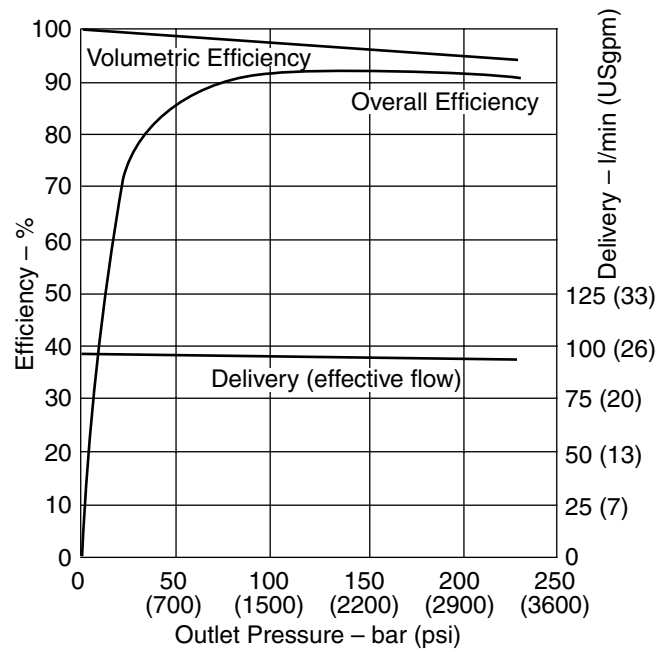

**Input Torque and Power at 1500 r/min, 50 °C (120 °F), and 1.0 bar absolute (0 psi gauge) Inlet**

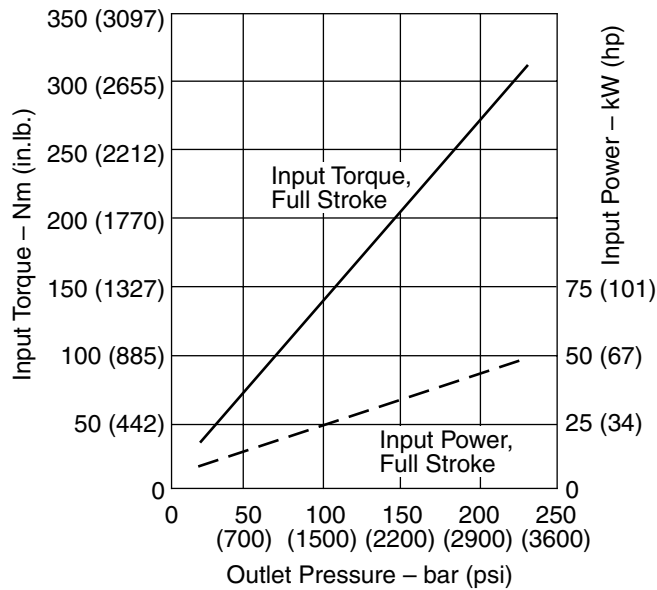

**Input Torque and Power at 1200 r/min, 50 °C (120 °F), and 1.0 bar absolute (0 psi gauge) Inlet**

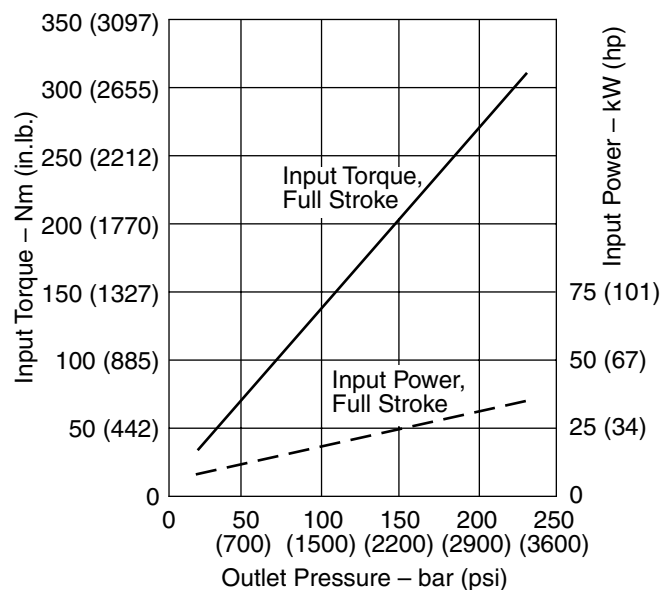

# Performance

Industrial PVM081

**Delivery and Efficiency at 1000 r/min, 50°C (120°F), and 1.0 bar absolute (0 psi gauge) Inlet**

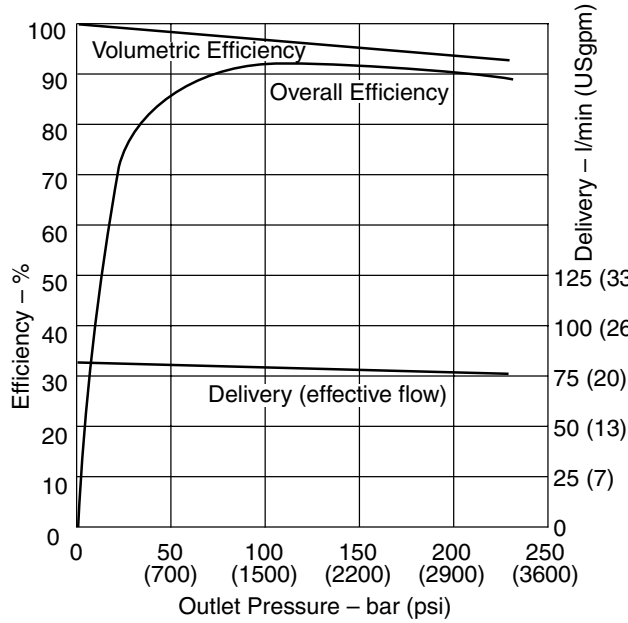

**Case Flow versus Outlet Pressure at 1800 r/min, Full Flow, 50°C (120°F), and 1.0 bar absolute (0 psi gauge) Inlet**

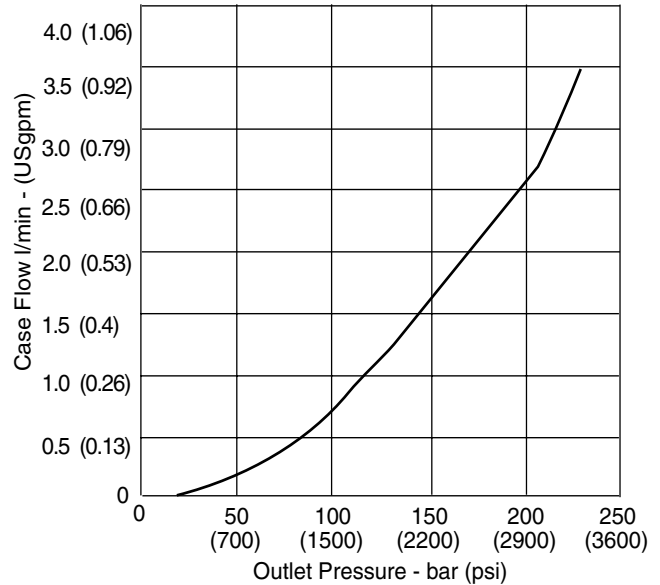

**Input Torque and Power at 1000 r/min, 50°C (120°F), and 1.0 bar absolute (0 psi gauge) Inlet**

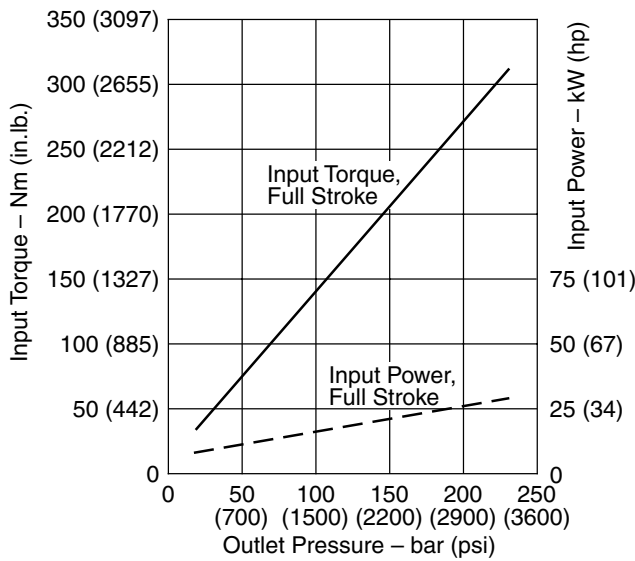

**Case Flow versus Outlet Pressure at Cutoff, 1800 r/min, 50°C (120°F), and 1.0 bar absolute (0 psi gauge) Inlet**

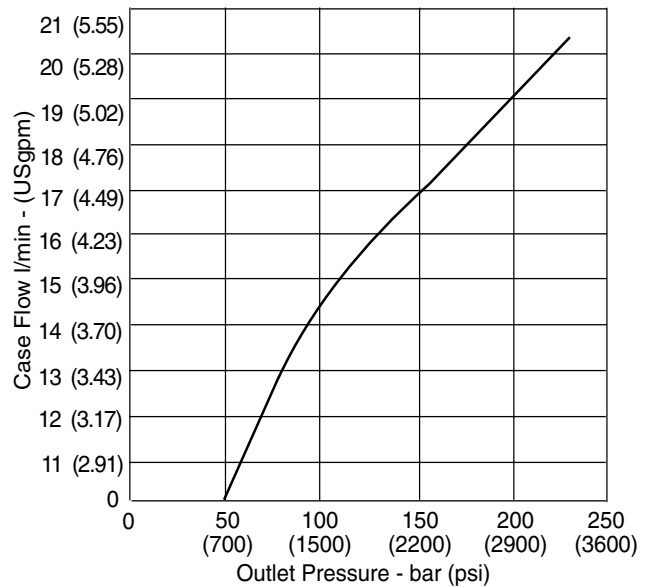

# Performance

Mobile PVM081

**Typical Noise Levels at 2400 & 600 r/min with Petroleum Oil (10W) at 93°C (200°F) and 1.0 bar absolute (0 psi gauge) Inlet**

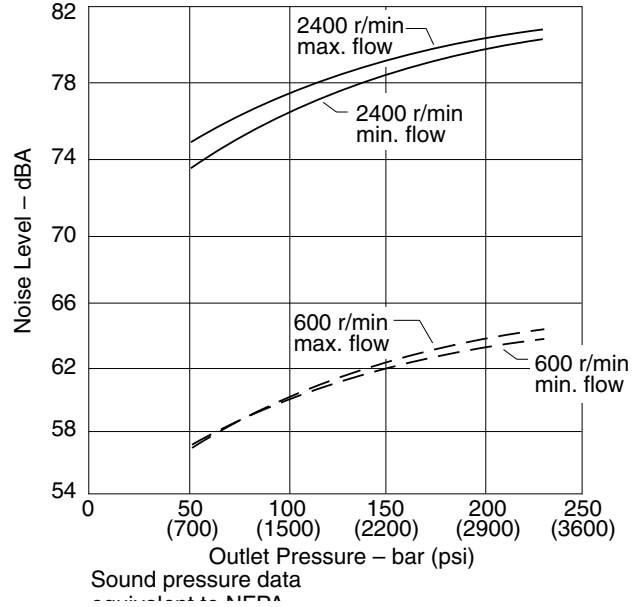

**Overall Efficiency versus Speed at 93°C (200°F) and 1.0 bar absolute (0 psi gauge) inlet**

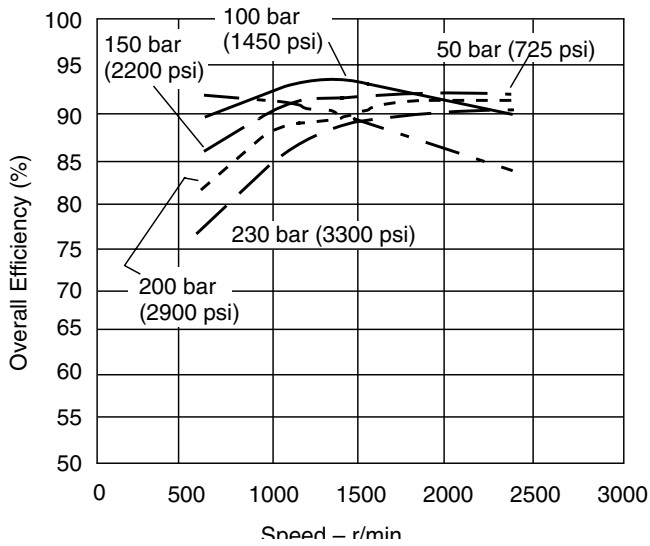

**Delivery and Case Flow versus Speed at 93°C (200°F), Full Flow 1.0 bar absolute (0 psi gauge) Inlet**

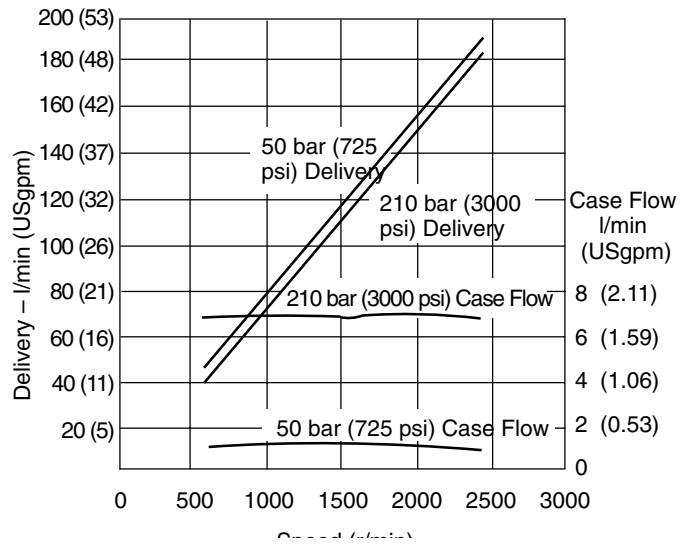

# Performance

Mobile PVM081

**Input Torque versus Speed at 93°C (200°F), Full Flow and 1.0 bar absolute (0 psi gauge) Inlet**

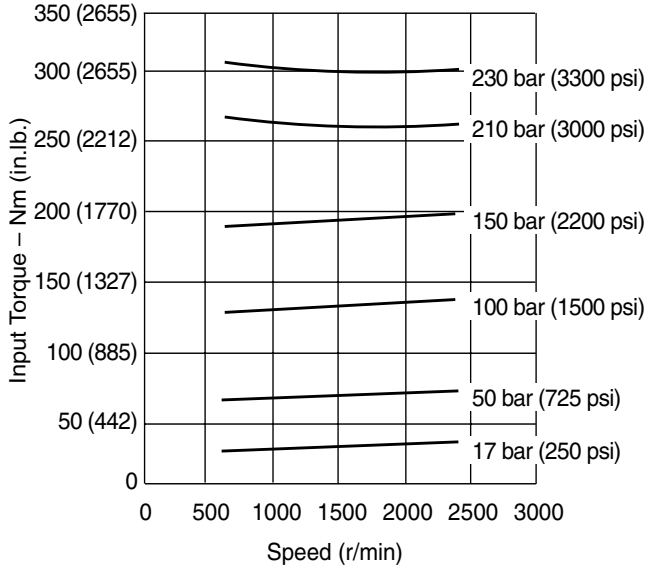

**Input Power versus Speed at 93°C (200°F), Full Flow and 1.0 bar absolute (0 psi gauge) Inlet**

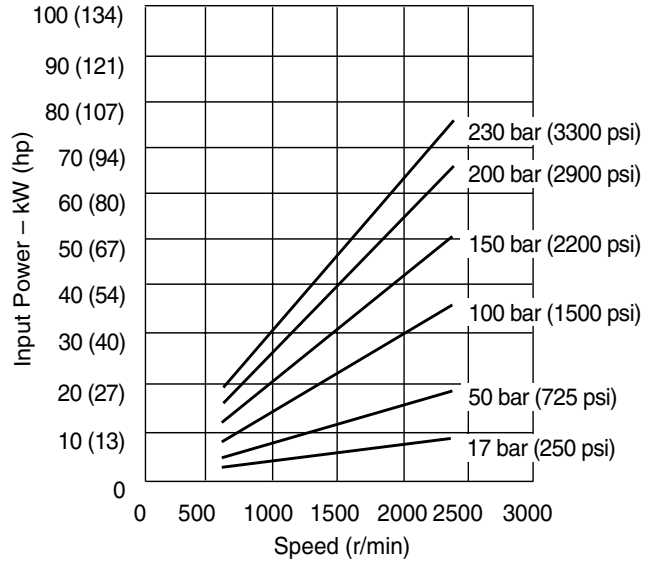

**Input Torque and Case Flow versus Speed at 93°C (200°F), Load Sense Standby and 1.0 bar absolute (0 psi gauge) Inlet**

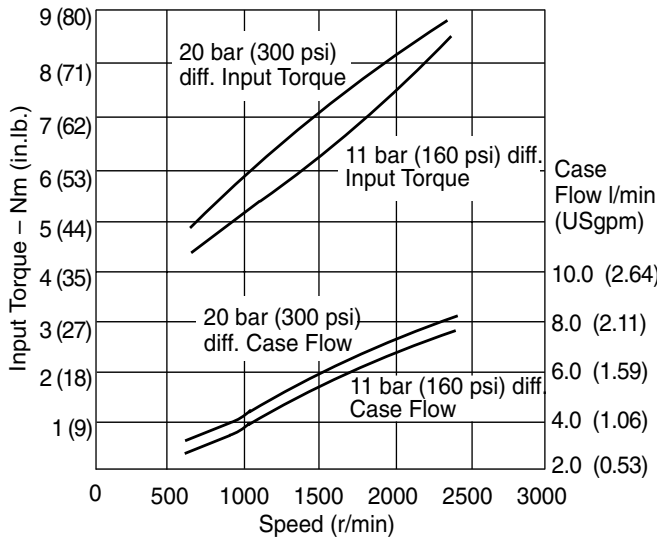

**Input Torque and Case Flow versus Speed at 93°C (200°F), Pressure Limit Cut-off and 1.0 bar absolute (0 psi gauge) Inlet**

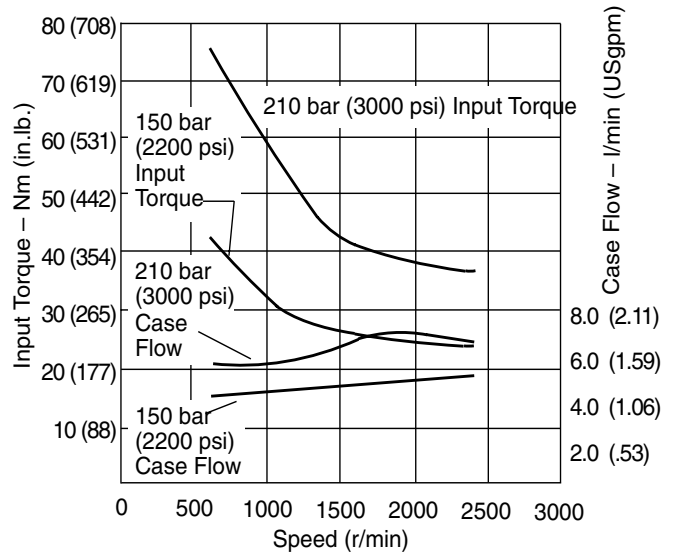

# Performance

Industrial PVM098

**Typical Noise Levels at 1800 and 1200 r/min**  
with Petroleum Oil (10W) at 50°C (120°F)  
and 1.0 bar absolute (0 psi gauge) Inlet

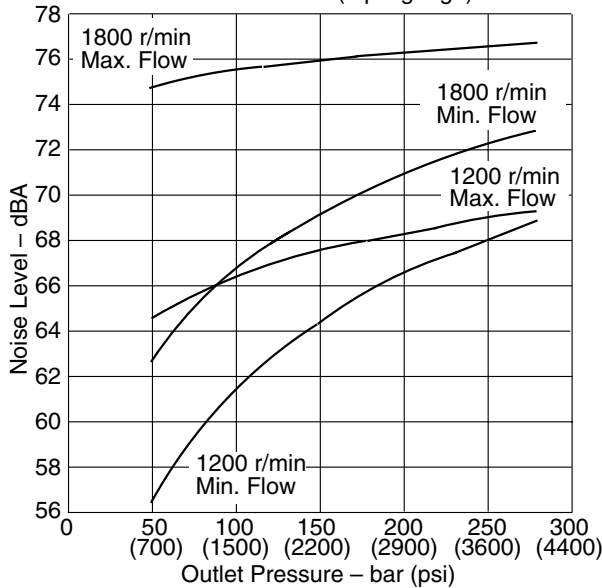

Sound pressure data  
equivalent to NFPA)

**Delivery and Efficiency at 1800 r/min**  
50°C (120°F) and 1.0 bar absolute (0 psi gauge) Inlet

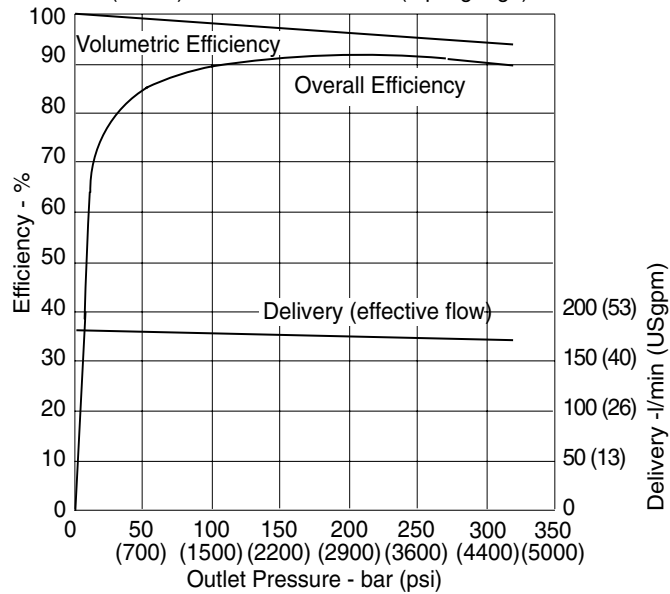

**Typical Noise Levels at 1500 and 1000 r/min**  
with Petroleum Oil (10W) at 50°C (120°F)  
and 1.0 bar absolute (0 psi gauge) Inlet

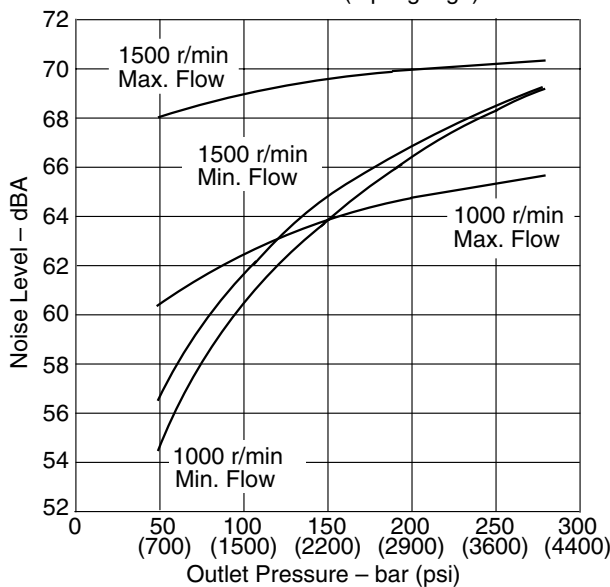

**Input Torque and Power at 1800 r/min**  
50°C (120°F) and 1.0 bar absolute (0 psi gauge) Inlet

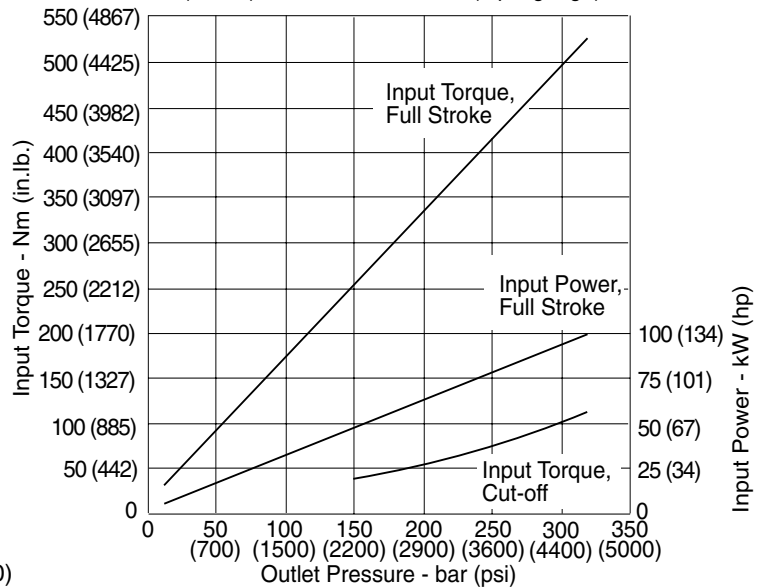

# Performance

Industrial PVM098

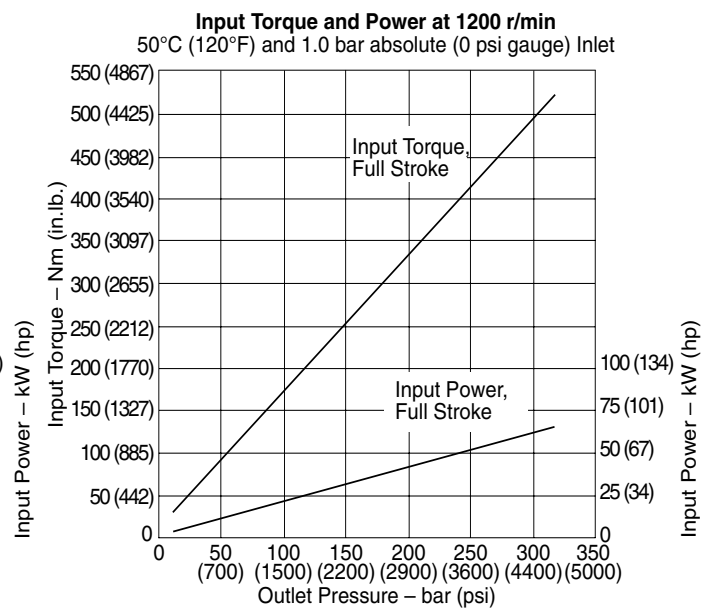
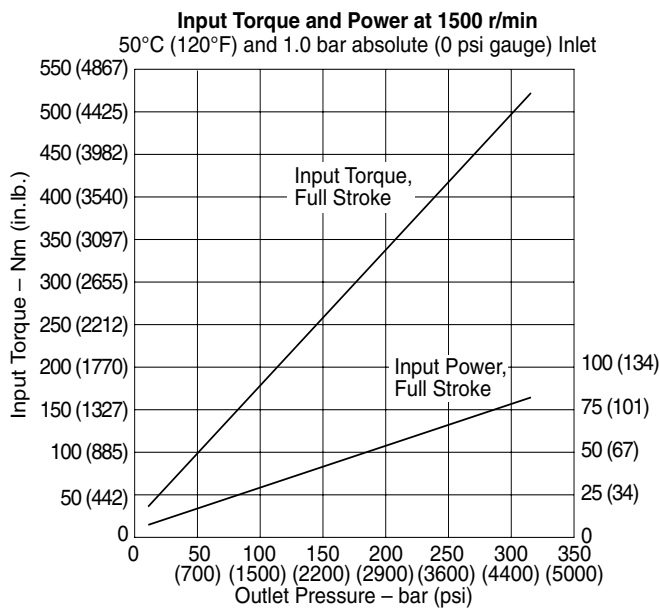
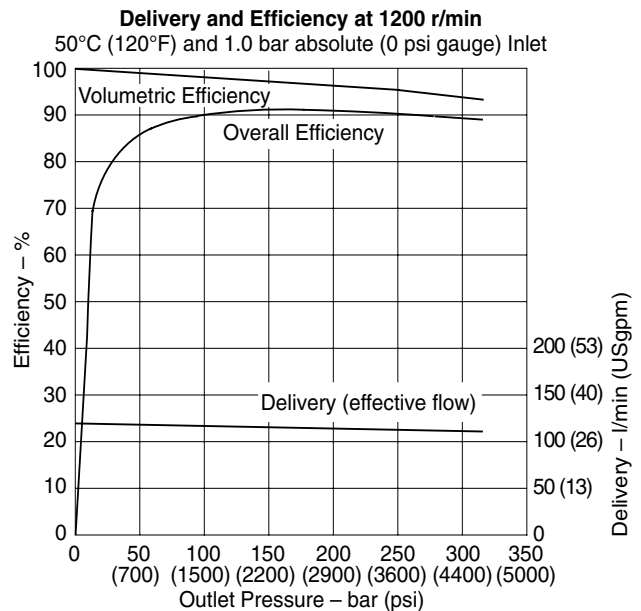
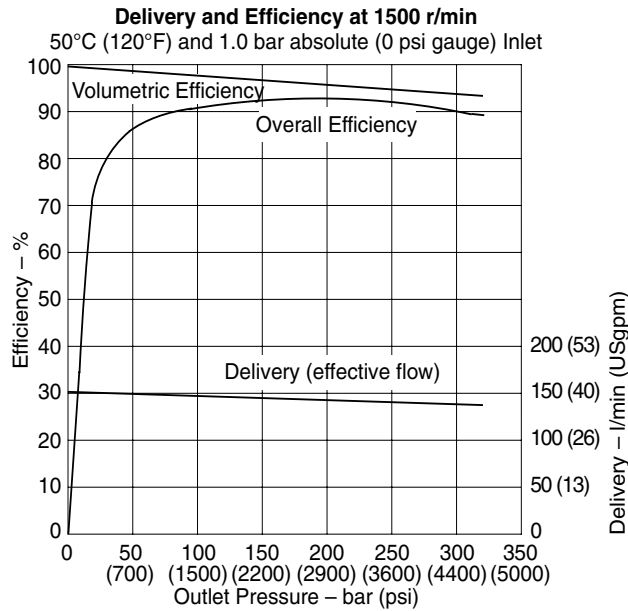



# Performance

Industrial PVM098

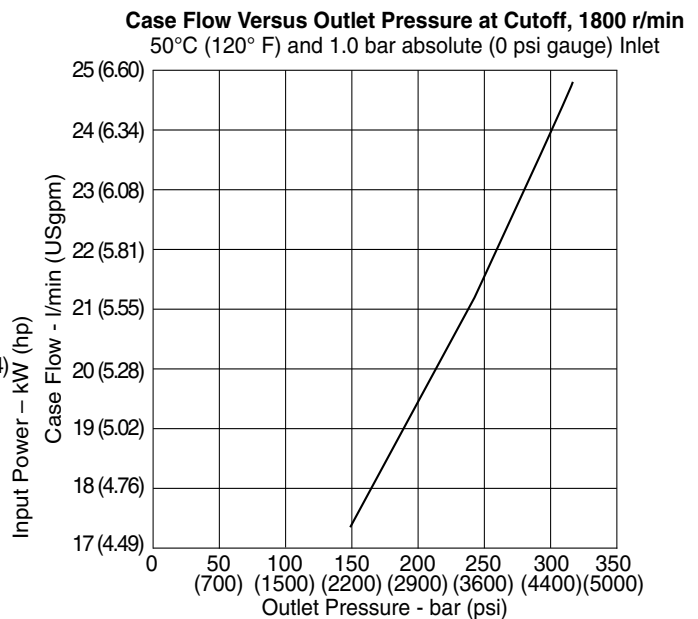
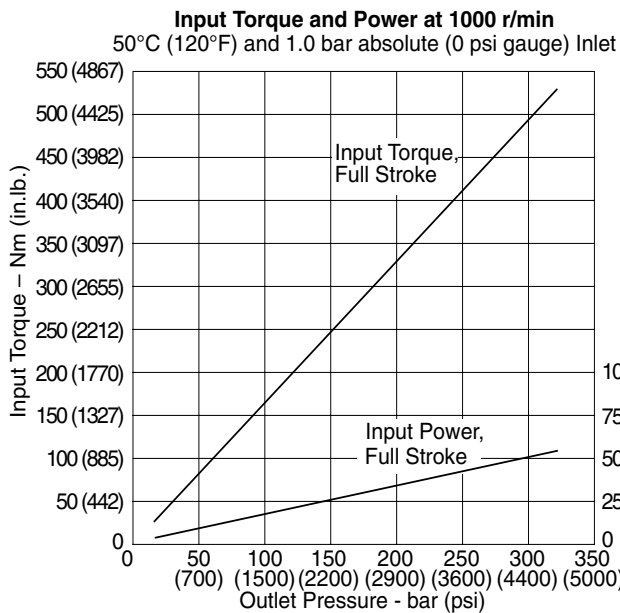
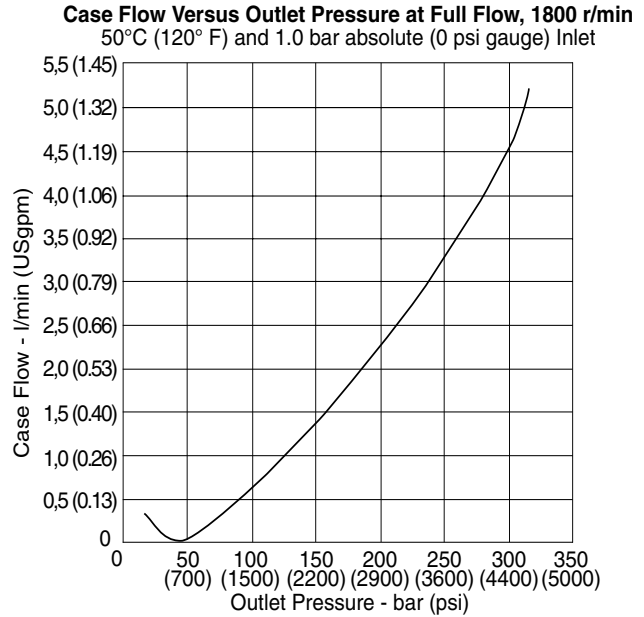
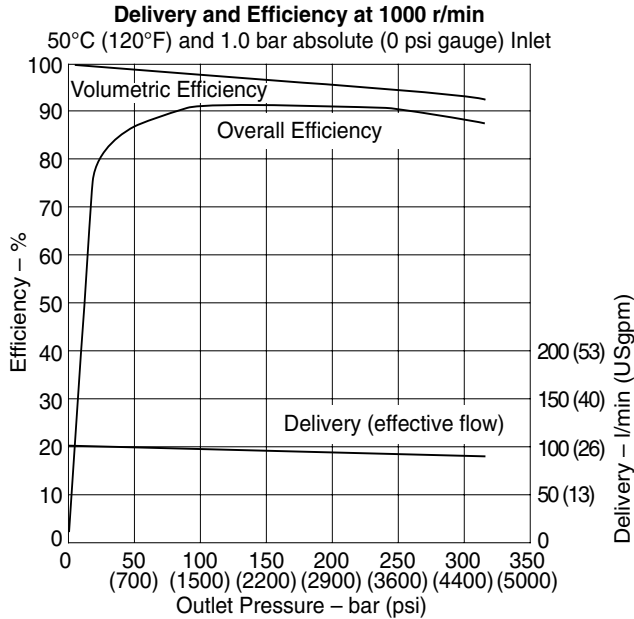

# Performance

Mobile PVM098

**Typical Noise Levels at 2000 and 600 r/min**  
with petroleum oil (10 W) @ 93°C (200°F)  
and 1.0 bar absolute (0 psi gauge) inlet

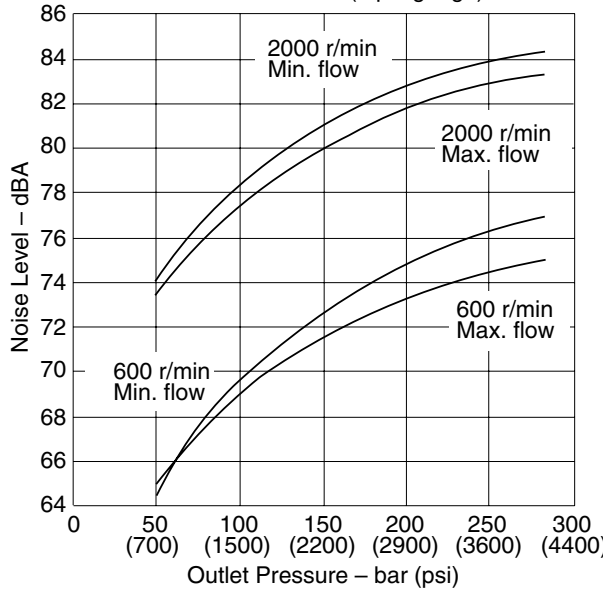

Sound pressure data equivalent to NFP

**Delivery and Case Flow Versus Speed**  
@ 93°C (200°F), full flow and  
1.0 bar absolute (0 psi) gauge Inlet

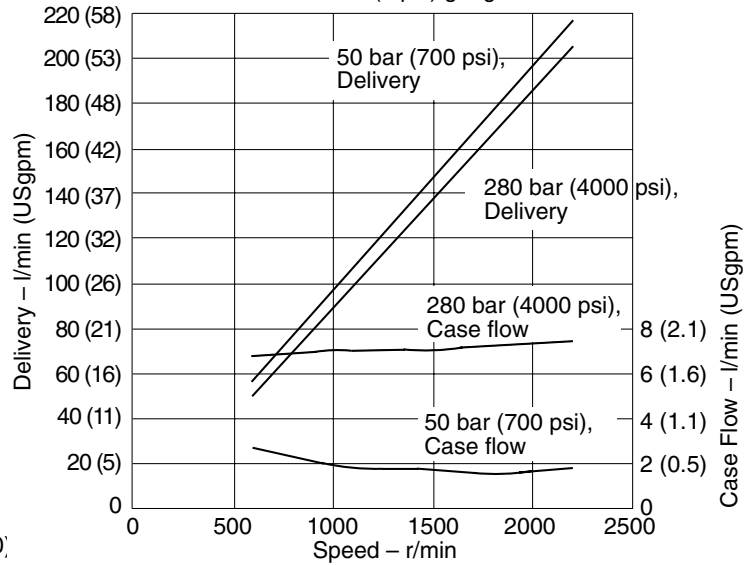

**Overall Efficiency Versus Speed**  
@ 93°C (200°F) and 1.0 bar absolute  
(0 psi gauge) inlet

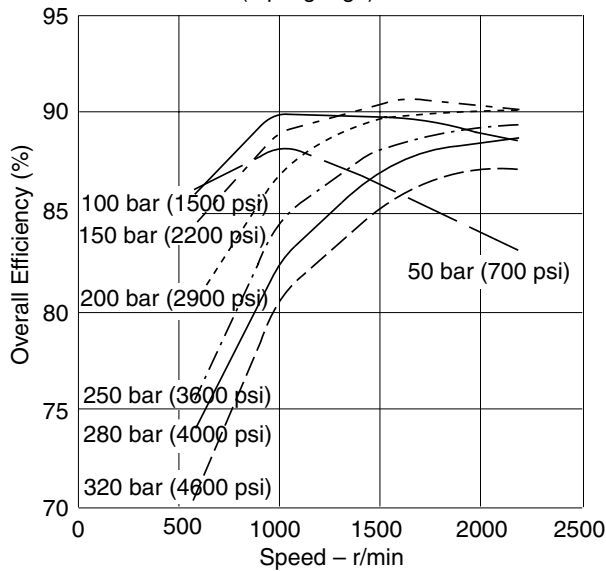

**Input Torque Versus Speed**  
@ 93°C (200°F), full flow and  
1.0 bar absolute (0 psi) gauge inlet

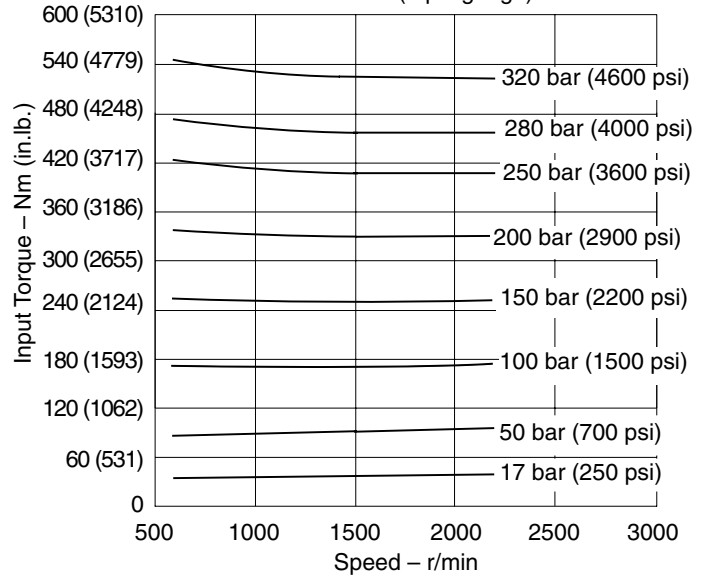

# Performance

Mobile PVM098

**Input Power Versus Speed**  
@ 93°C (200°F), full flow and  
1.0 bar absolute (0 psi gauge) inlet

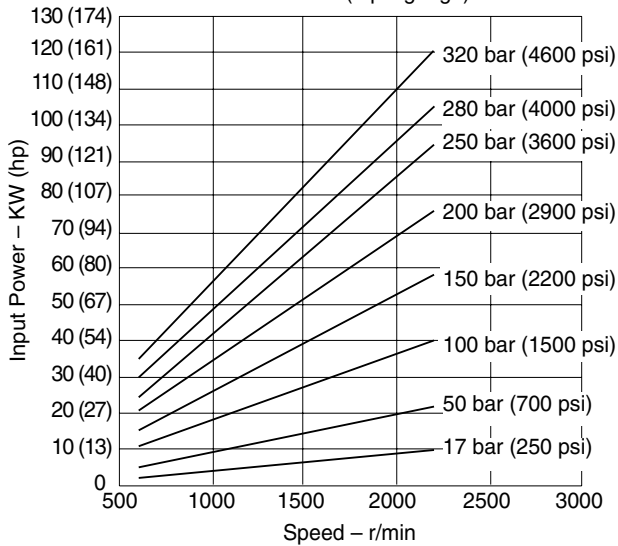

**Input Torque and Case Flow Versus Speed**  
@ 93°C (200°F), cut-off and  
1.0 bar absolute (0 psi gauge) inlet

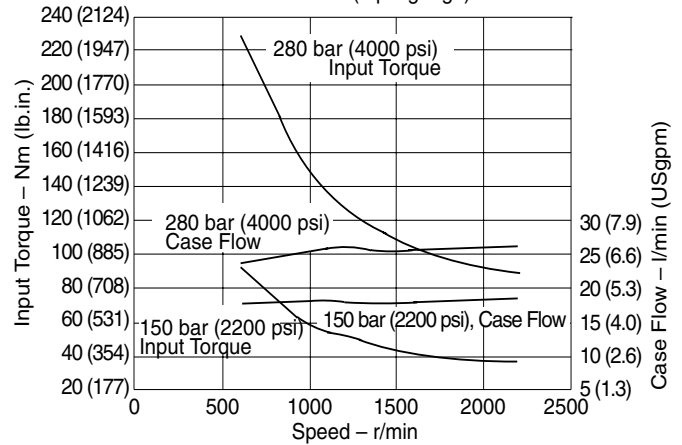

**Input Torque and Case Flow Versus Speed**  
@ 93°C (200°F), load sense standby  
and 1.0 bar absolute (0 psi gauge) inlet

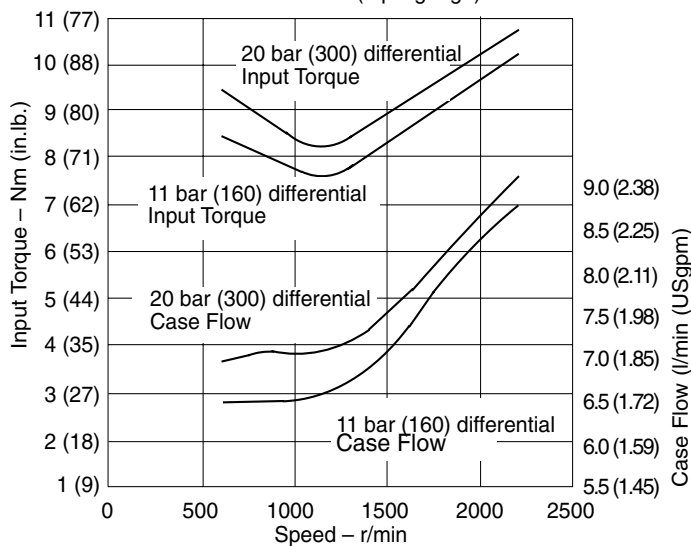

**Case Flow at 2200 r/min, Full Flow**  
93°C (200°F), 1.0 bar absolute (0 psi gauge) Inlet

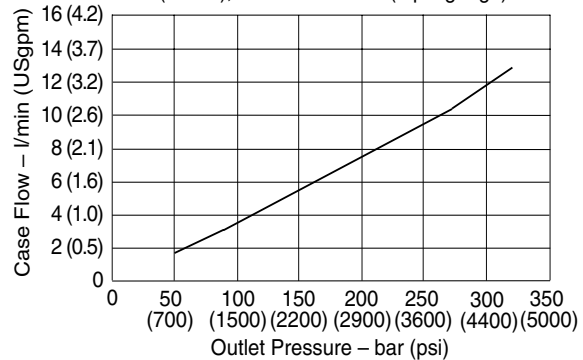

**Case Flow at 2200 r/min, Minimum Flow**  
93°C (200°F), 1.0 bar absolute (0 psi gauge) Inlet

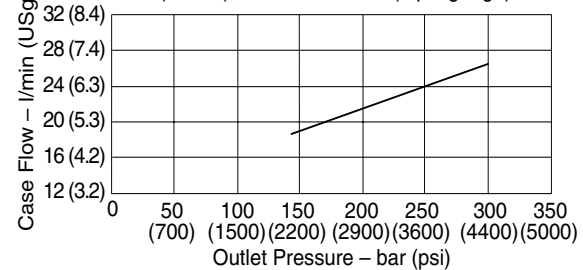

# Performance

Industrial PVM106

**Typical Noise Levels at 1800 and 1200 r/min. with Petroleum Oil (10W) at 50°C (120°F) and 1.0 bar absolute (0 psi gauge) Inlet**

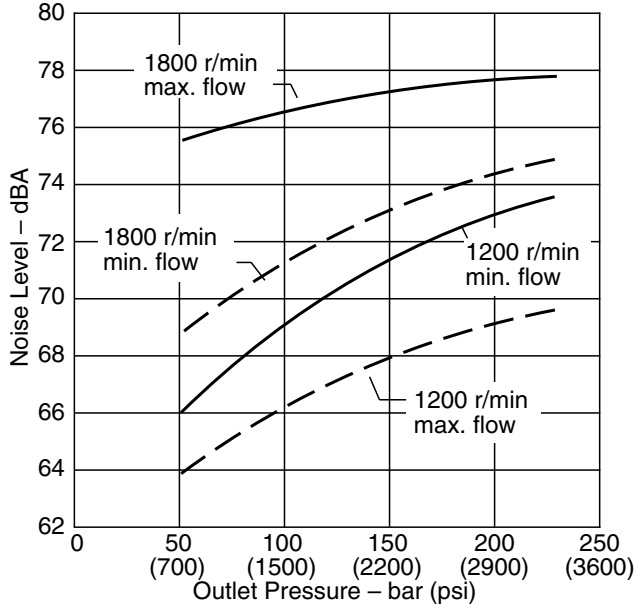

**Delivery and Efficiency at 1800 r/min, 50°C (120°F), and 1.0 bar absolute (0 psi gauge) Inlet**

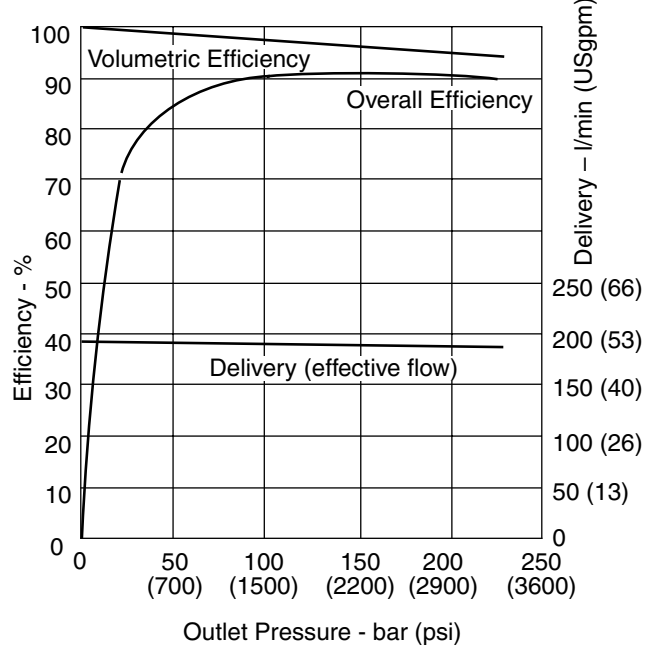

**Typical Noise Levels at 1500 and 1000 r/min. with Petroleum Oil (10W) at 50°C (120°F) and 1.0 bar absolute (0 psi gauge) Inlet**

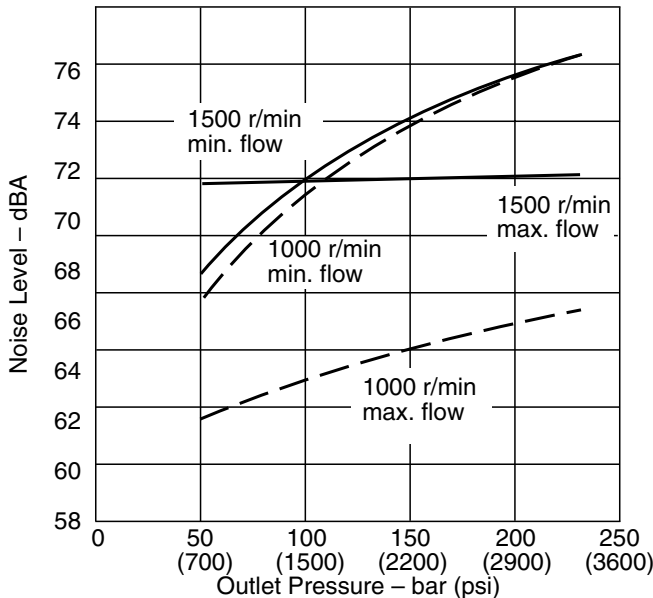

Sound pressure data equivalent to NFPA.

**Input Torque and Power at 1800 r/min, 50°C (120°F), and 1.0 bar absolute (0 psi gauge) Inlet**

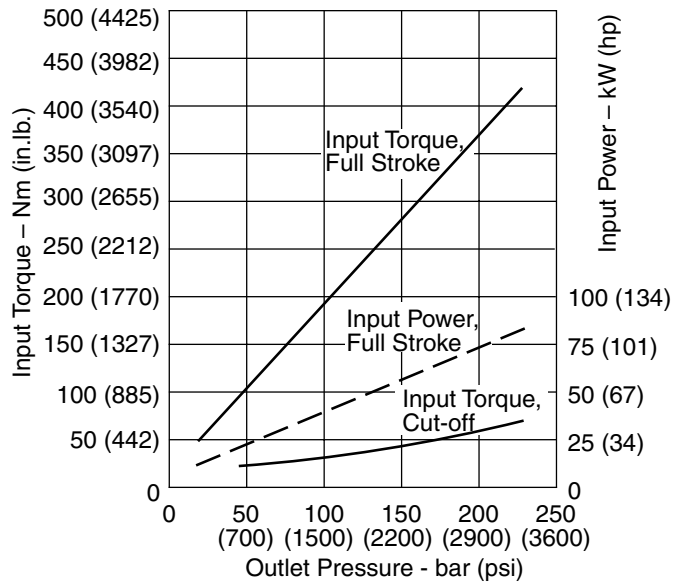

# Performance

Industrial PVM106

**Delivery and Efficiency at 1500 r/min, 50 °C (120 °F), and 1.0 bar absolute (0 psi gauge) Inlet**

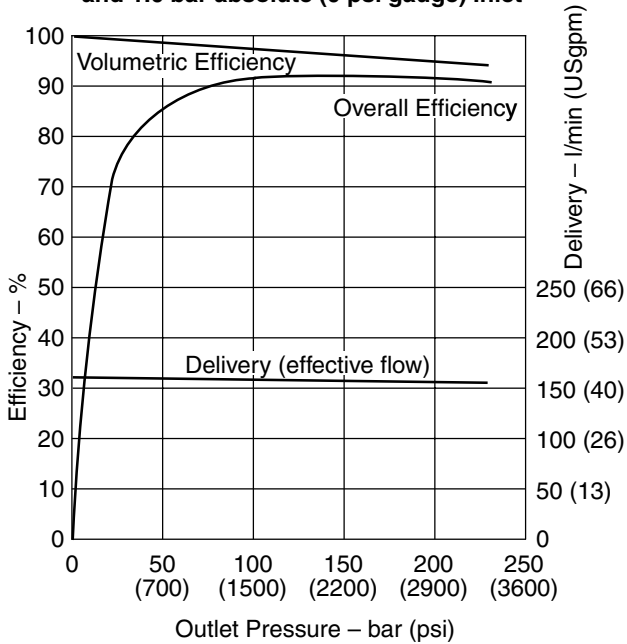

**Delivery and Efficiency at 1200 r/min, 50 °C (120 °F), and 1.0 bar absolute (0 psi gauge) Inlet**

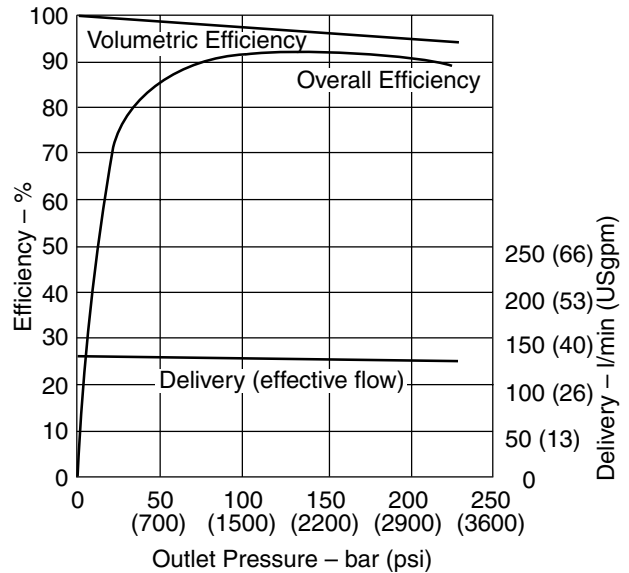

**Input Torque and Power at 1500 r/min, 50 °C (120 °F), and 1.0 bar absolute (0 psi gauge) Inlet**

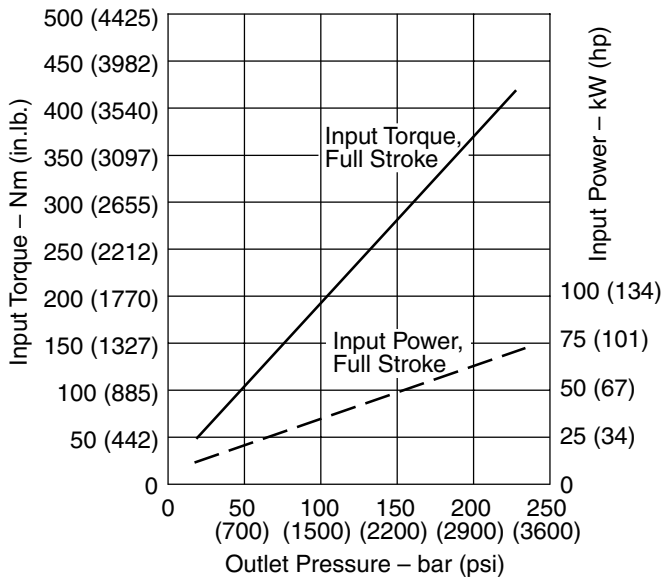

**Input Torque and Power at 1200 r/min, 50 °C (120 °F), and 1.0 bar absolute (0 psi gauge) Inlet**

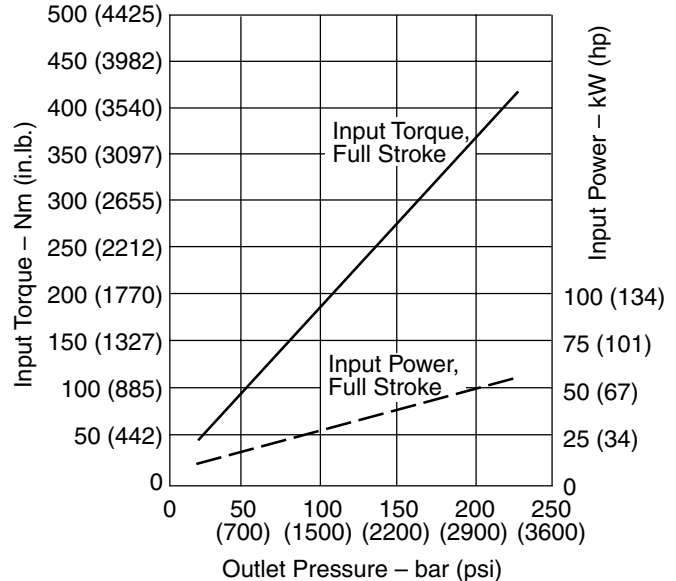

# Performance

Industrial PVM106

**Delivery and Efficiency at 1000 r/min, 50°C (120°F), and 1.0 bar absolute (0 psi gauge) Inlet**

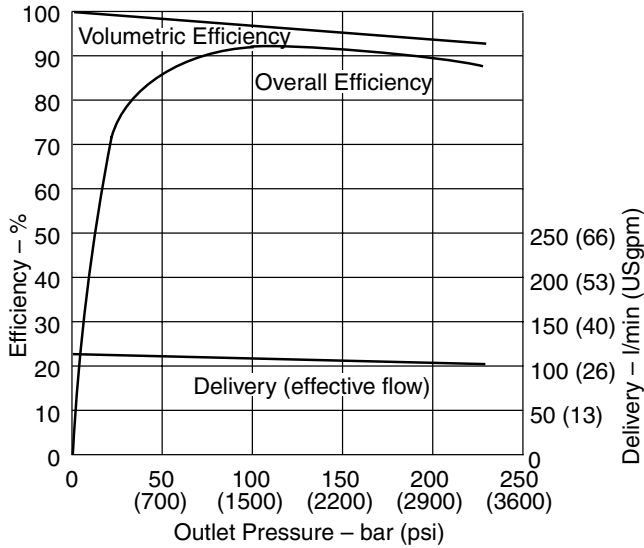

**Case Flow versus Outlet Pressure at 1800 r/min, Full Flow, 50°C (120°F), and 1.0 bar absolute (0 psi gauge) Inlet**

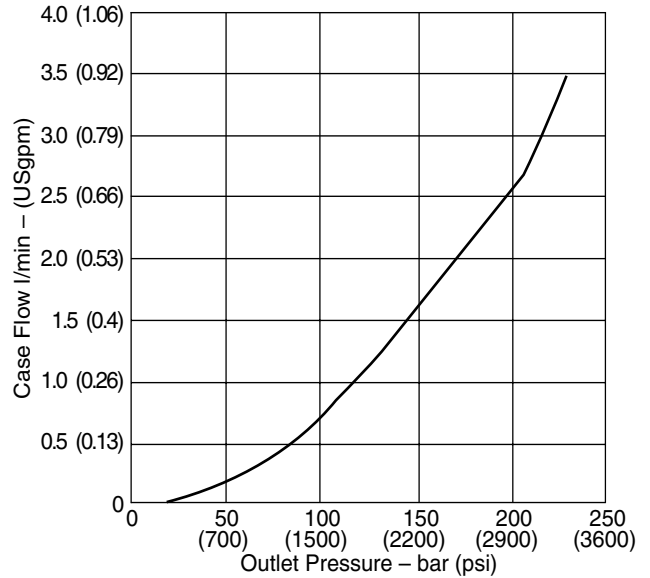

**Input Torque and Power at 1000 r/min, 50°C (120°F), and 1.0 bar absolute (0 psi gauge) Inlet**

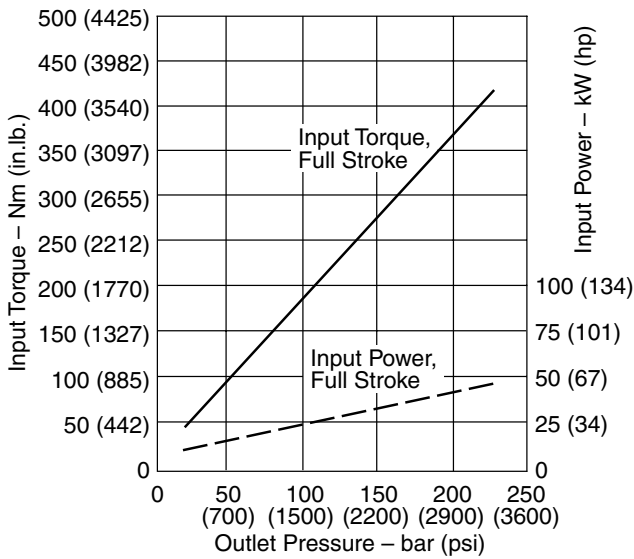

**Case Flow versus Outlet Pressure at Cutoff, 1800 r/min, 50°C (120°F), and 1.0 bar absolute (0 psi gauge) Inlet**

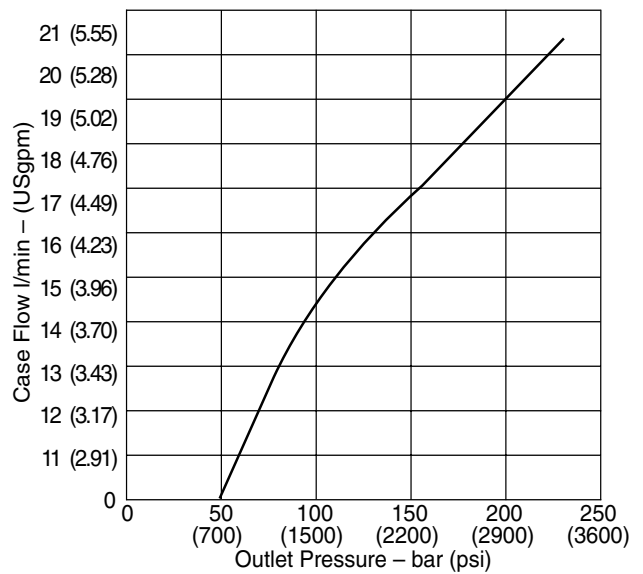

# Performance

Mobile PVM106

**Typical Noise Levels at 2200 & 600 r/min with Petroleum Oil (10W) at 93°C (200°F) and 1.0 bar absolute (0 psi gauge) Inlet**

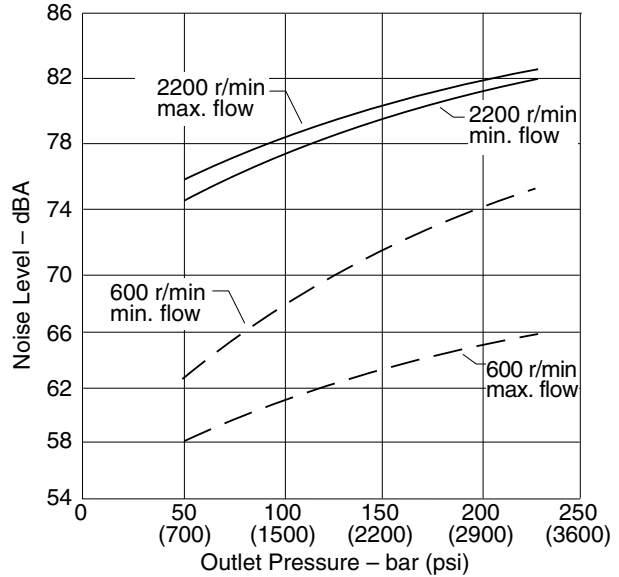

Sound pressure data equivalent to NFPA.

**Overall Efficiency versus Speed at 93°C (200°F) and 1.0 bar absolute (0 psi gauge) inlet**

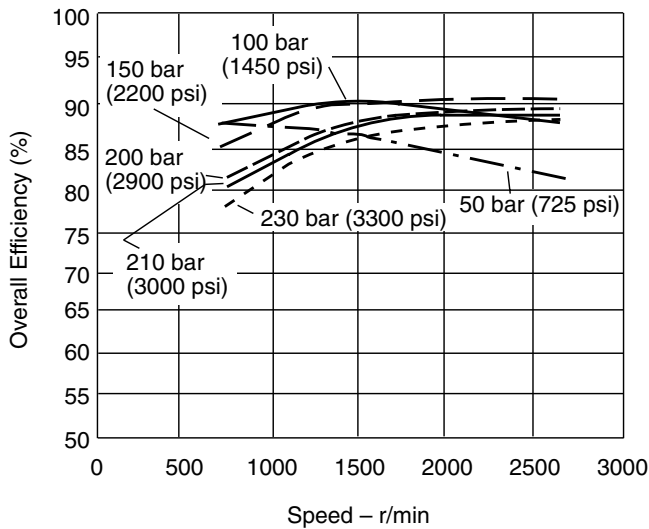

**Delivery and Case Flow versus Speed at 93°C (200°F), Full Flow 1.0 bar absolute (0 psi gauge) Inlet**

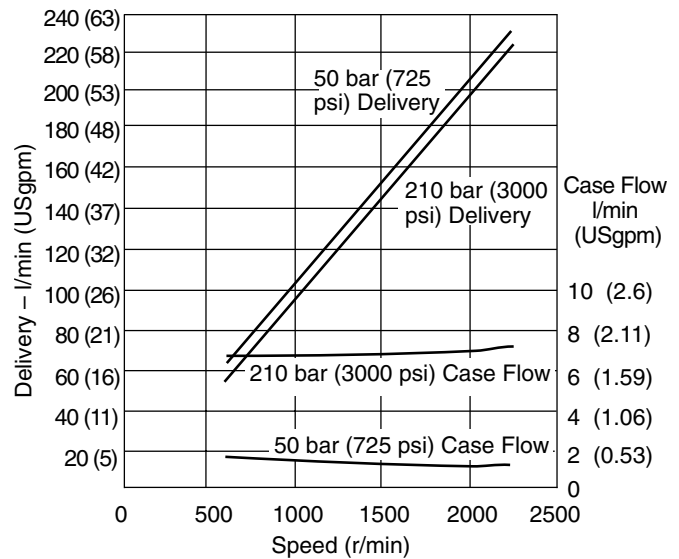

# Performance

Mobile PVM106

**Input Torque versus Speed at 93°C (200°F), Full Flow and 1.0 bar absolute (0 psi gauge) Inlet**

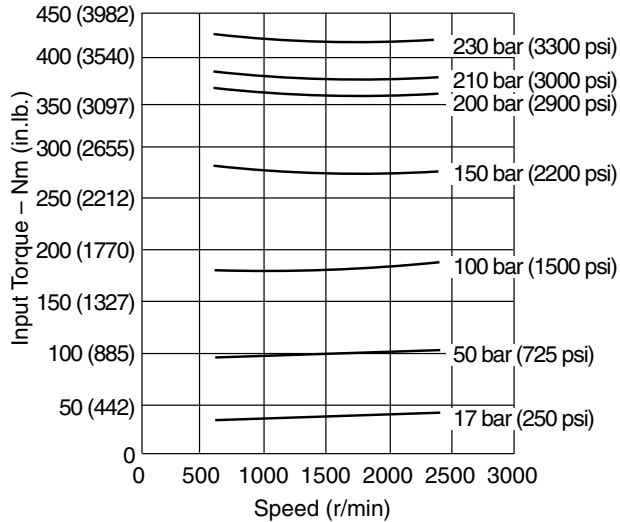

**Input Power versus Speed at 93°C (200°F), Full Flow and 1.0 bar absolute (0 psi gauge) Inlet**

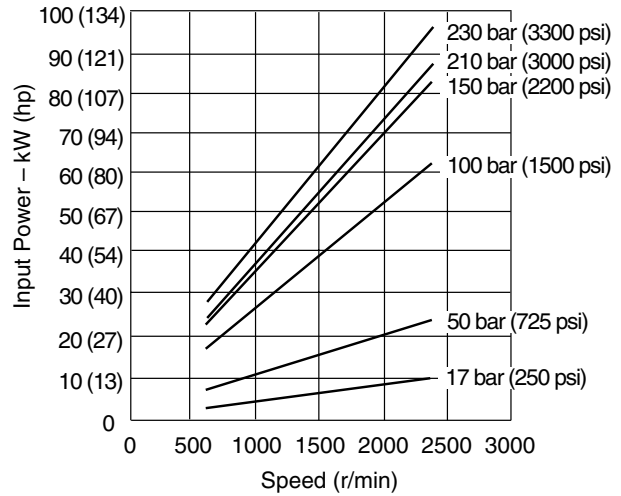

**Input Torque and Case Flow versus Speed at 93°C (200°F), Load Sense Standby and 1.0 bar absolute (0 psi gauge) Inlet**

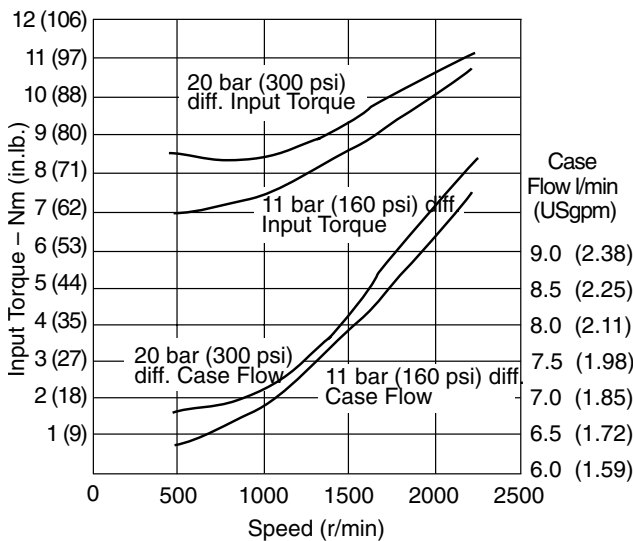

**Input Torque and Case Flow versus Speed at 93°C (200°F), Pressure Limit Cut-off and 1.0 bar absolute (0 psi gauge) Inlet**

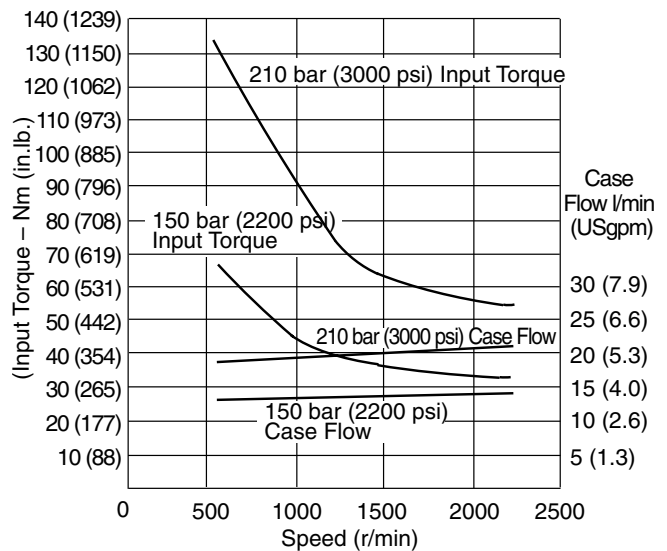



# Performance

Industrial PVM131

**Typical Noise Levels at 1800 and 1200 r/min**  
with Petroleum Oil (10W) at 50°C (120°F)  
and 1.0 bar absolute (0 psi gauge) Inlet

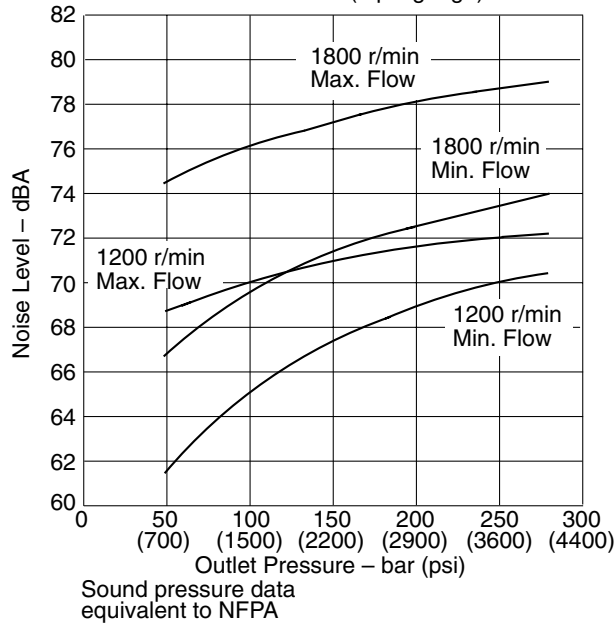

**Delivery and Efficiency at 1800 r/min**  
50°C (120°F) and 1.0 bar absolute (0 psi gauge) Inlet

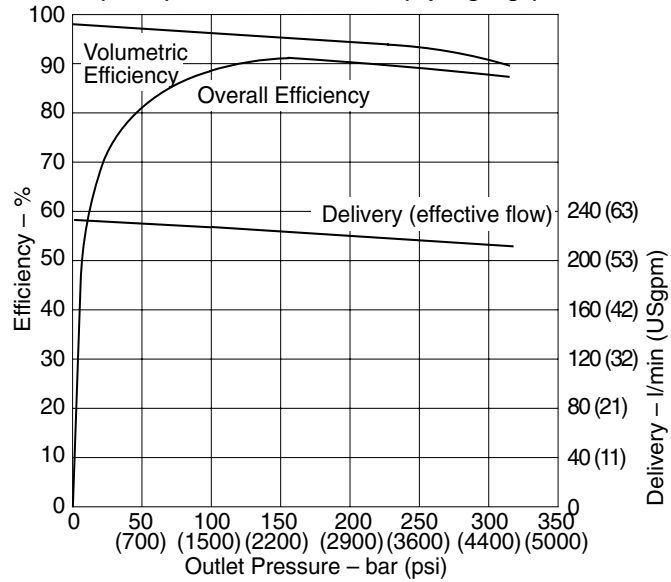

**Typical Noise Levels at 1500 and 1000 r/min**  
with Petroleum Oil (10W) at 50°C (120°F)  
and 1.0 bar absolute (0 psi gauge) Inlet

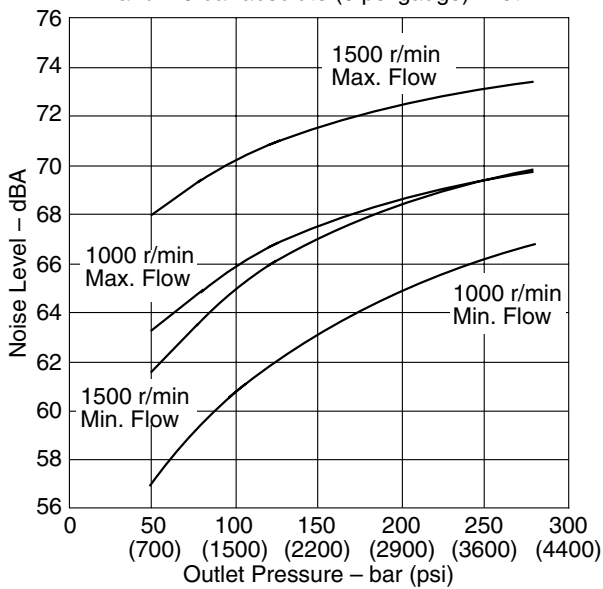

**Input Torque and Power at 1800 r/min**  
50°C (120°F) and 1.0 bar absolute (0 psi gauge) Inlet

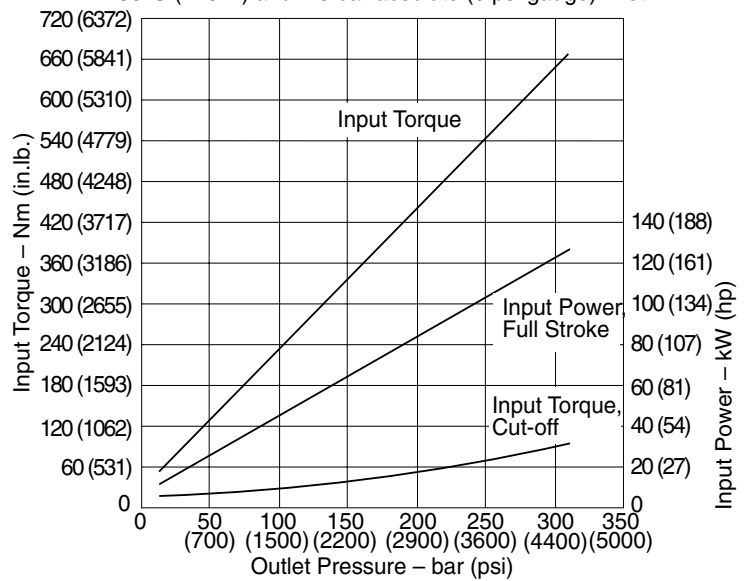

# Performance

Industrial PVM131

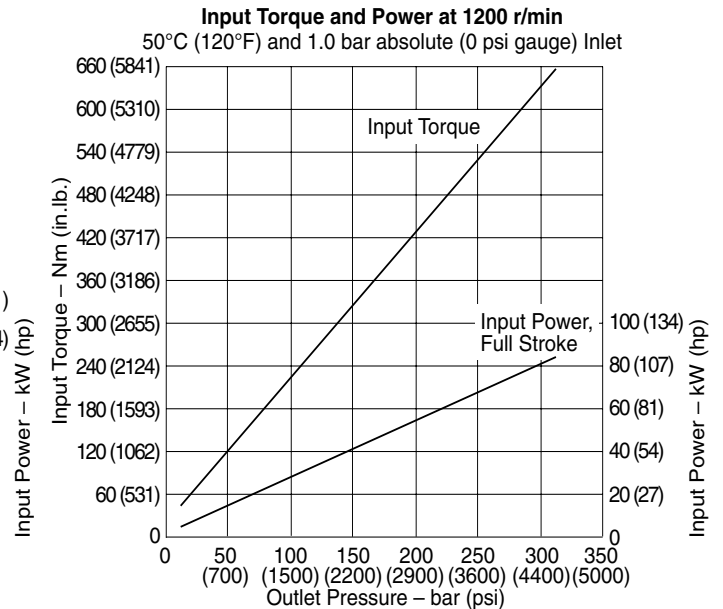
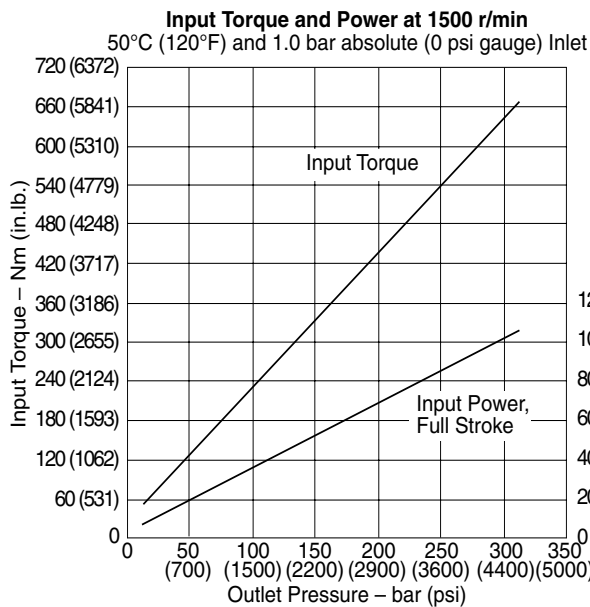
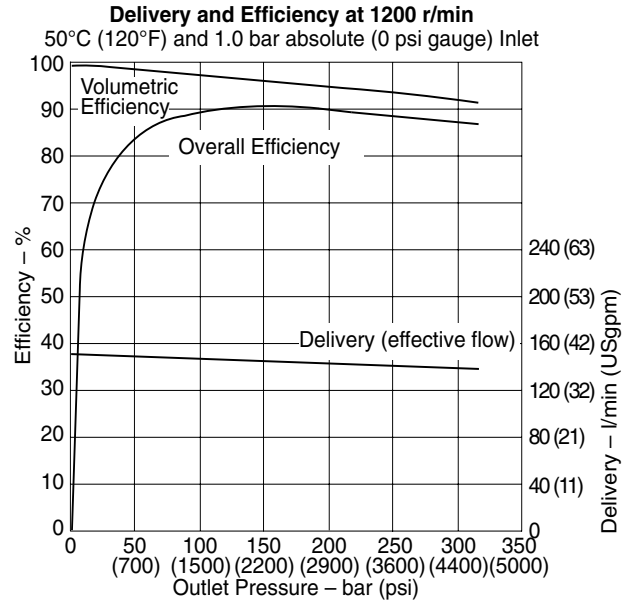
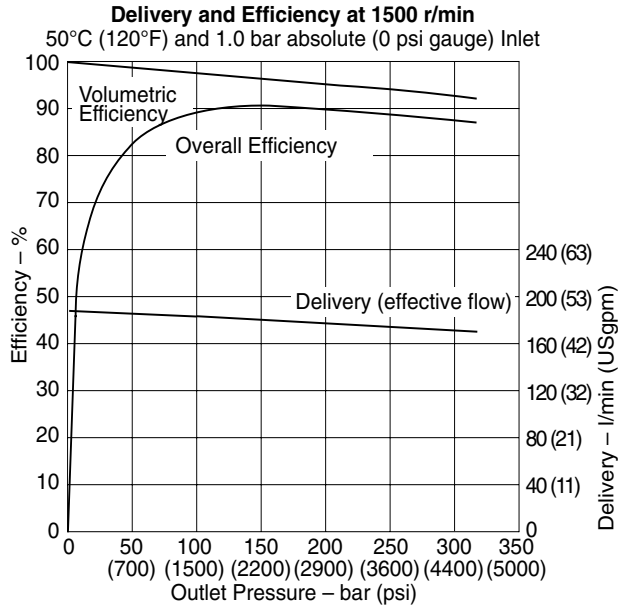

# Performance

Industrial PVM131

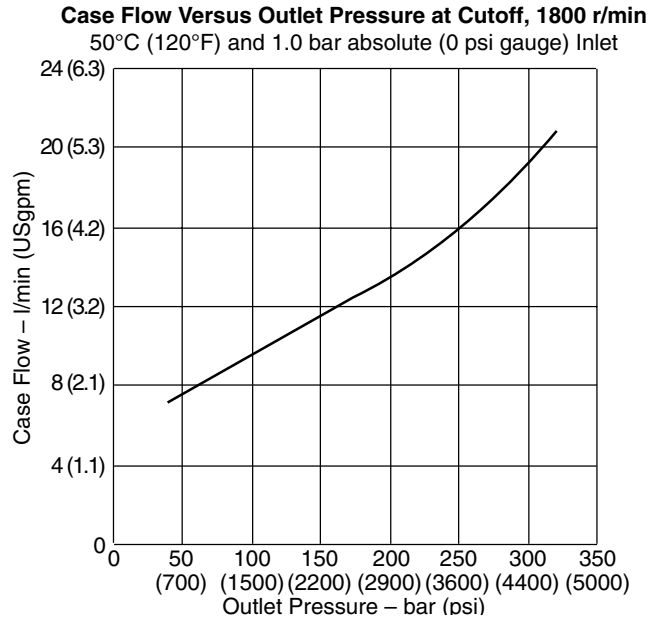
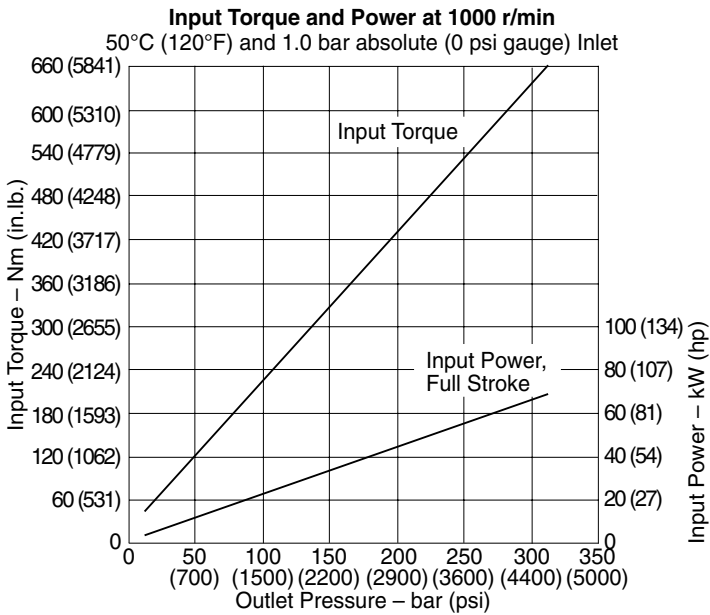
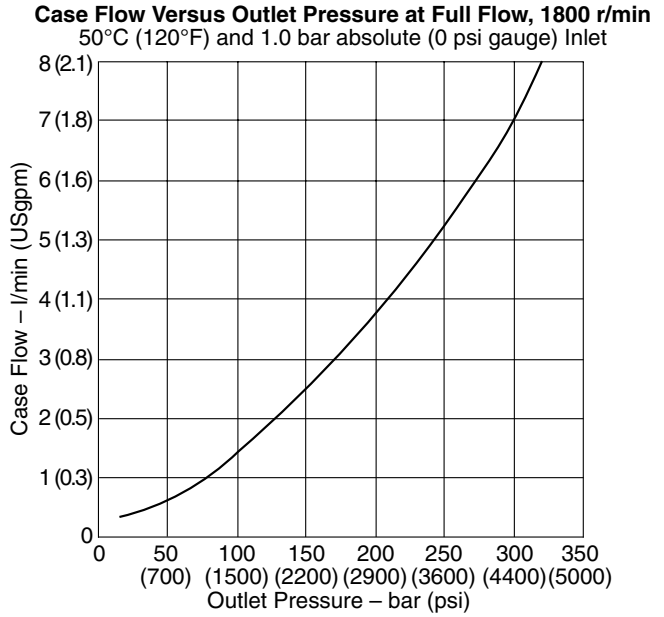
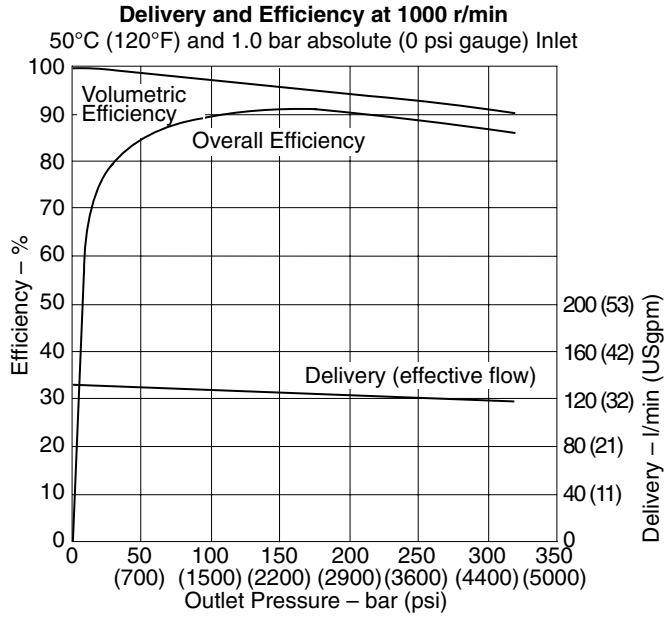

# Performance

Mobile PVM131

**Typical Noise Levels at 2000 and 600 r/min**  
with petroleum oil (10 W) @ 93°C (200°F)  
and 1.0 bar absolute (0 psi gauge) inlet

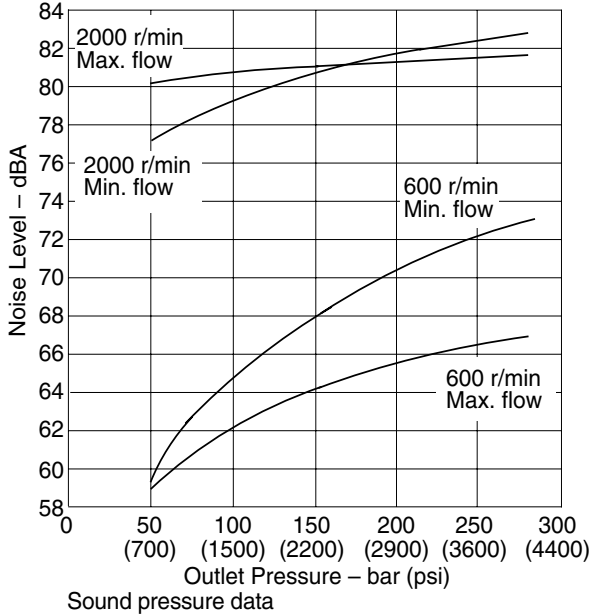

**Delivery and Case Flow Versus Speed**  
@ 93°C (200°F), full flow and  
1.0 bar absolute (0 psi) gauge Inlet

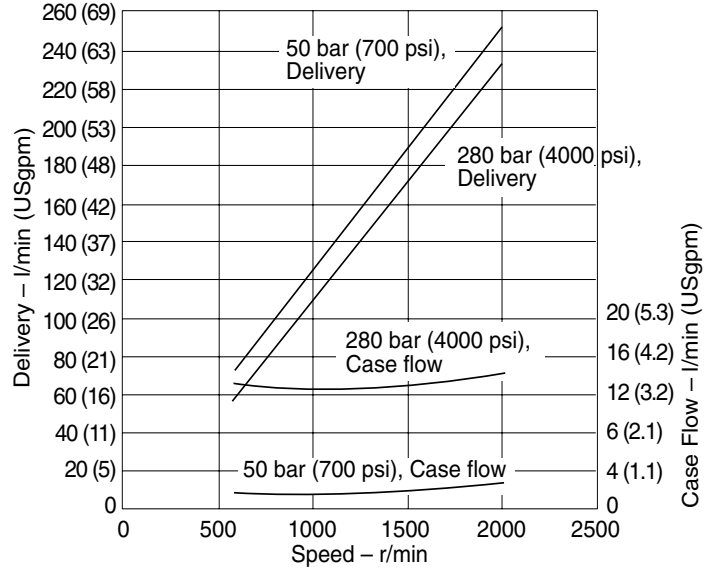

**Overall Efficiency Versus Speed**  
@ 93°C (200°F) and 1.0 bar absolute  
(0 psi gauge) inlet

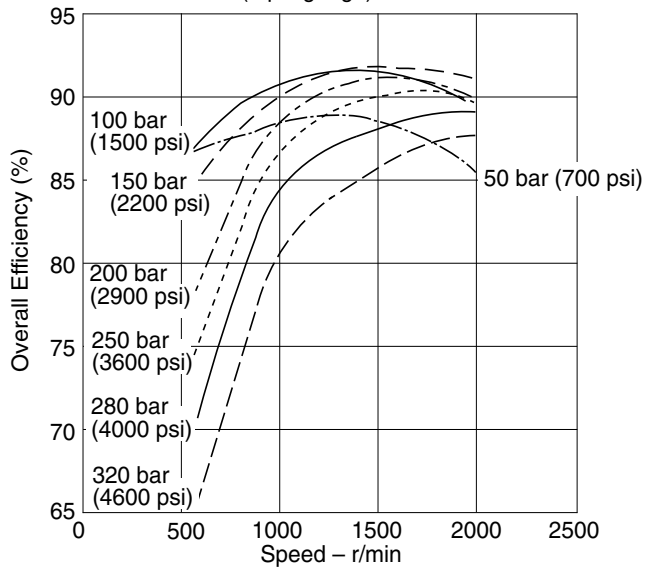

**Input Torque Versus Speed**  
@ 93°C (200°F), full flow and  
1.0 bar absolute (0 psi gauge) inlet

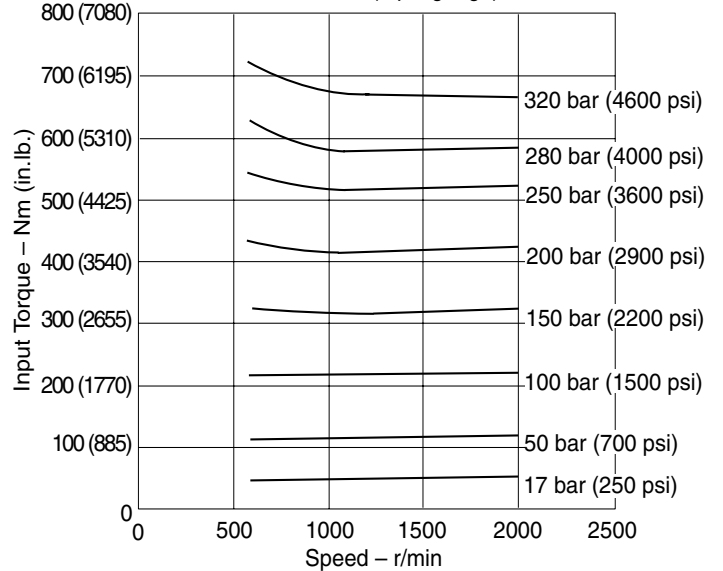

# Performance

Mobile PVM131

## Input Power Versus Speed

@ 93°C (200°F), full flow and  
1.0 bar absolute (0 psi gauge) inlet

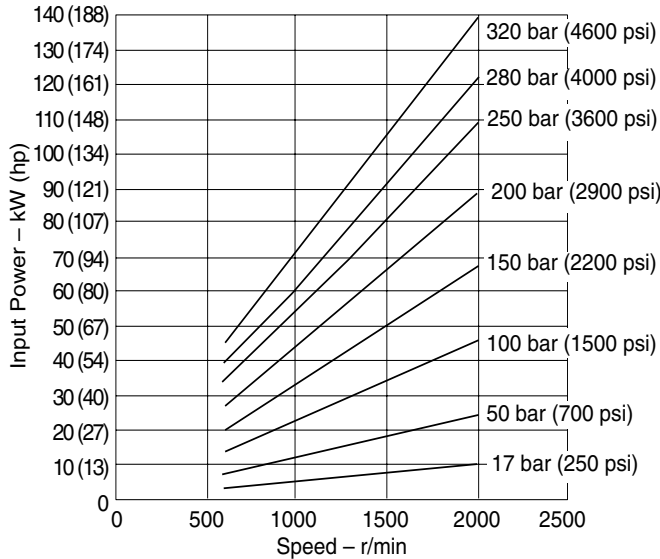

## Input Torque and Case Flow Versus Speed

@ 93°C (200°F), cut-off and  
1.0 bar absolute (0 psi gauge) inlet

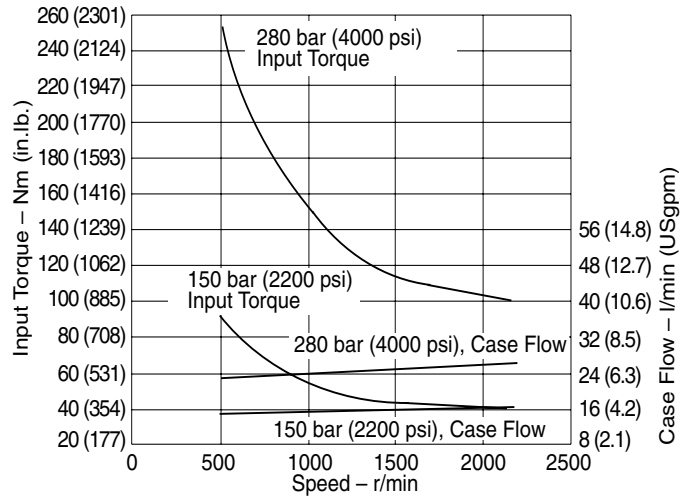

## Input Torque and Case Flow Versus Speed

@ 93°C (200°F), load sense standby  
and 1.0 bar absolute (0 psi gauge) inlet

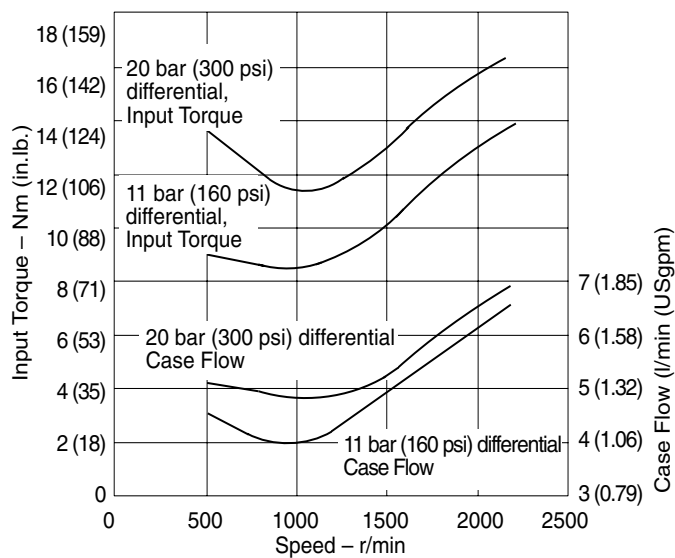

## Case Flow at 2000 r/min, Full Flow

93°C (200°F), 1.0 bar absolute (0 psi gauge) Inlet

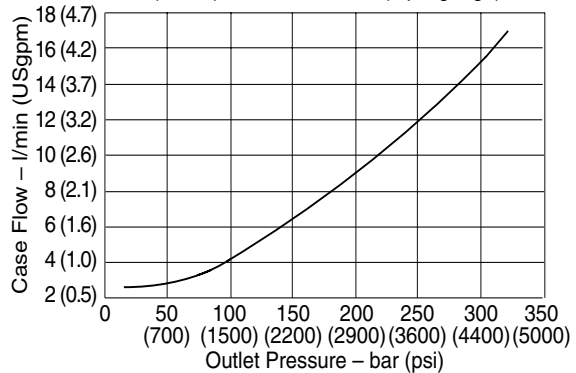

## Case Flow at 2000 r/min, Minimum Flow

93°C (200°F), 1.0 bar absolute (0 psi gauge) Inlet

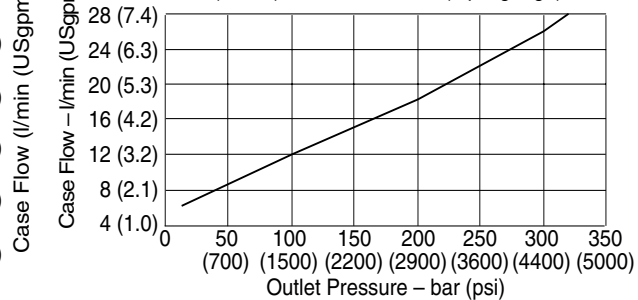

# Performance

Industrial PVM141

**Typical Noise Levels at 1800 and 1200 r/min with Petroleum Oil (10W) at 50°C (120°F) and 1.0 bar absolute (0 psi gauge) Inlet**

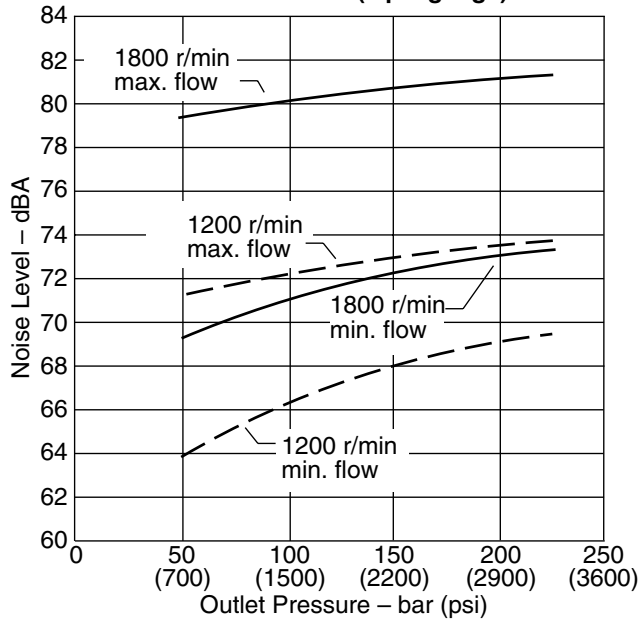

**Delivery and Efficiency at 1800 r/min, 50°C (120°F), and 1.0 bar absolute (0 psi gauge) Inlet**

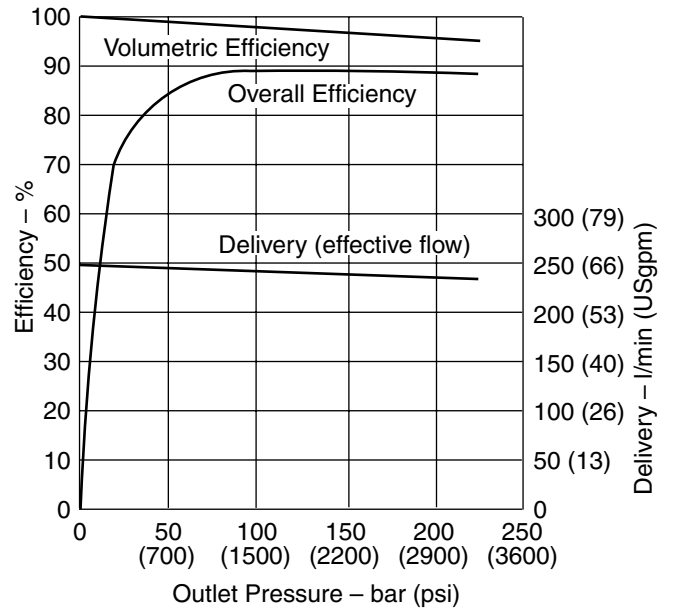

**Typical Noise Levels 1500 and 1000 r/min with Petroleum Oil (10W) at 50°C (120°F) and 1.0 bar absolute (0 psi gauge) Inlet**

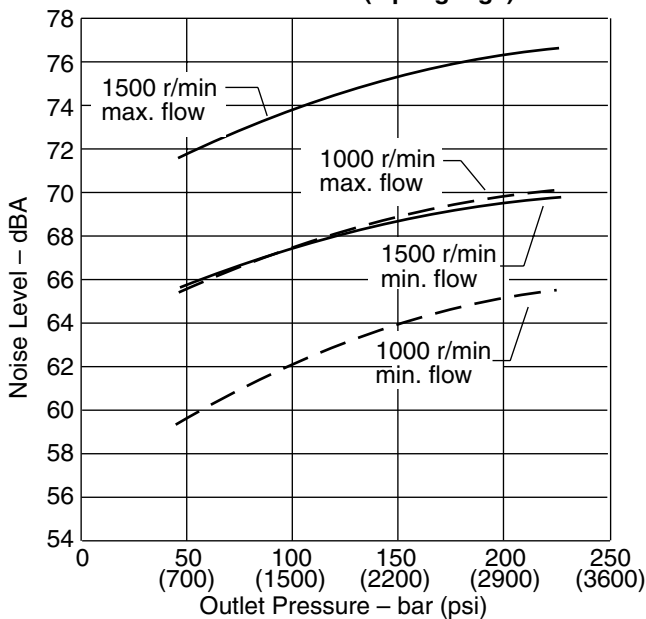

**Input Torque and Power at 1800 r/min, 50°C (120°F), and 1.0 bar absolute (0 psi gauge) Inlet**

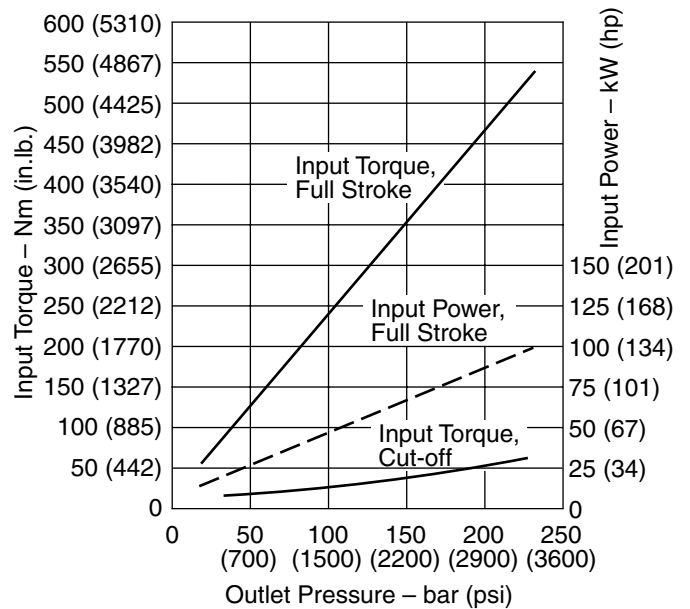

Sound pressure data equivalent to NFPA.

# Performance

Industrial PVM141

**Delivery and Efficiency at 1500 r/min, 50°C (120°F), and 1.0 bar absolute (0 psi gauge) Inlet**

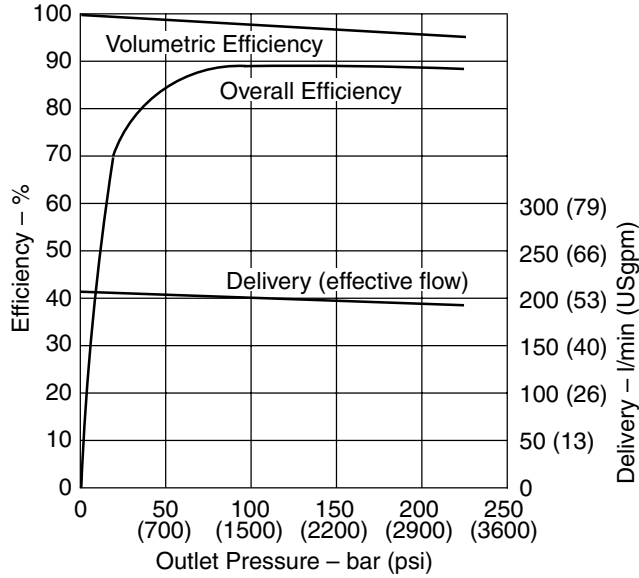

**Delivery and Efficiency at 1200 r/min, 50°C (120°F), and 1.0 bar absolute (0 psi gauge) Inlet**

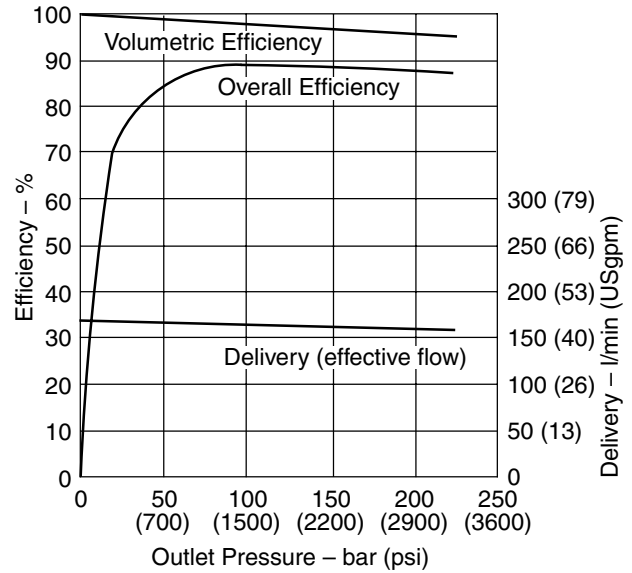

**Input Torque and Power at 1500 r/min, 50°C (120°F), and 1.0 bar absolute (0 psi gauge) Inlet**

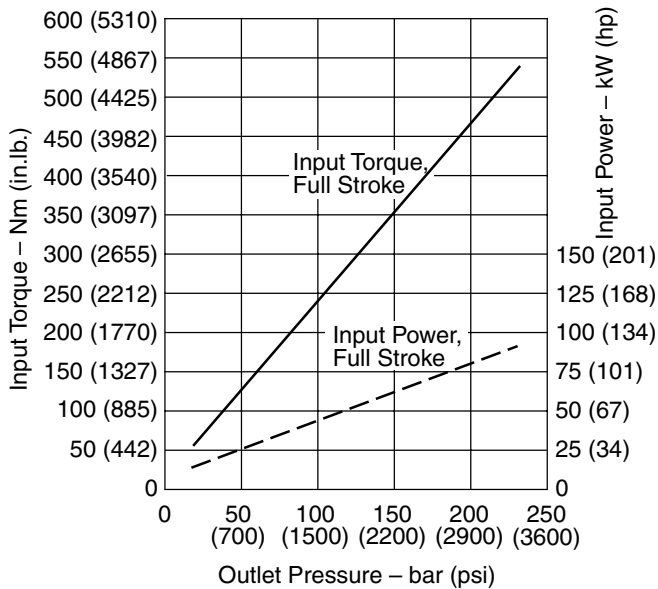

**Input Torque and Power at 1200 r/min, 50°C (120°F), and 1.0 bar absolute (0 psi gauge) Inlet**

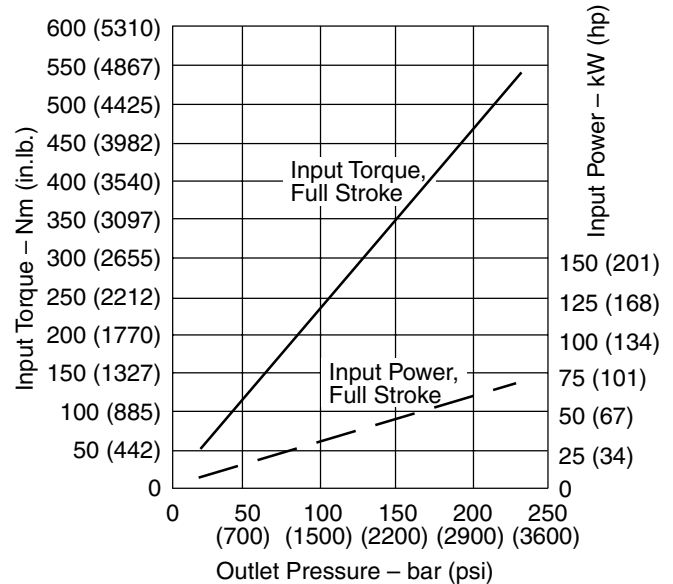

# Performance

Industrial PVM141

**Delivery and Efficiency at 1000 r/min, 50°C (120°F), and 1.0 bar absolute (0 psi gauge) Inlet**

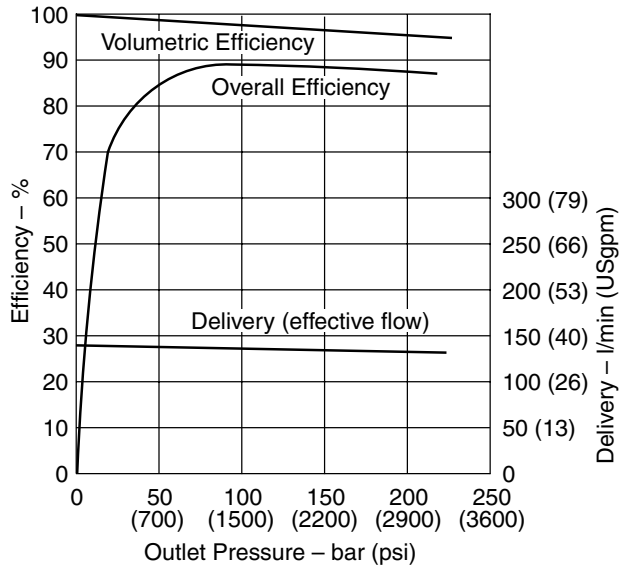

**Case Flow Versus Outlet Pressure at Full Flow, 1800 r/min 50°C (120°F) and 1.0 bar absolute (0 psi gauge) Inlet**

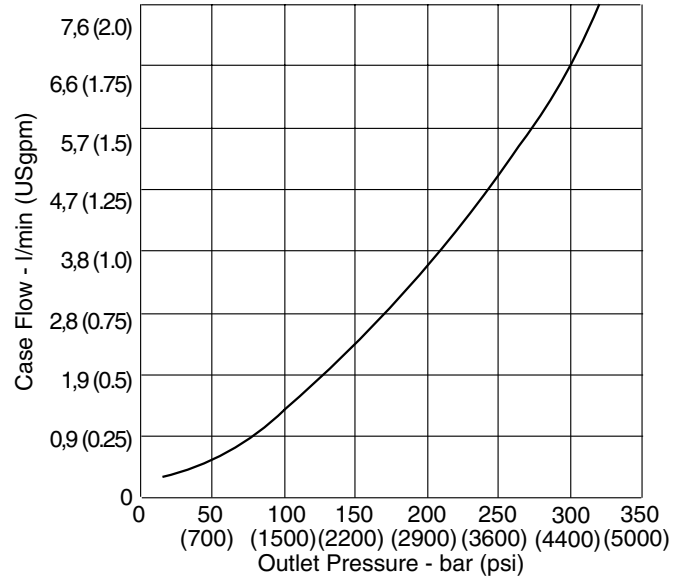

**Input Torque and Power at 1000 r/min, 50°C (120°F), and 1.0 bar absolute (0 psi gauge) Inlet**

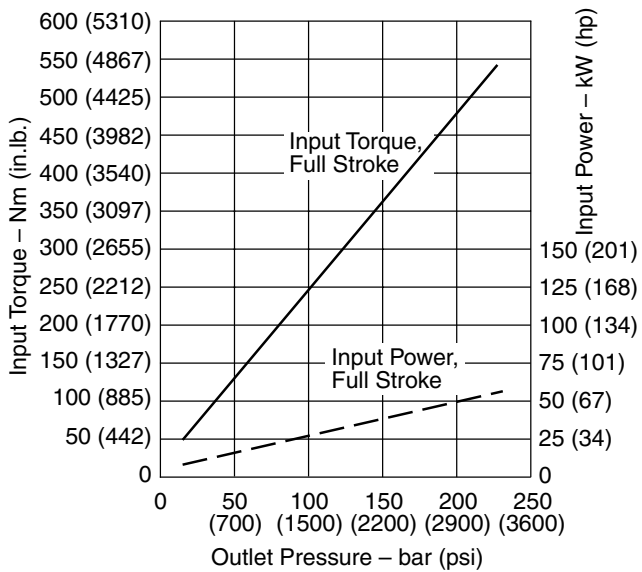

**Case Flow Versus Outlet Pressure at Cutoff, 1800 r/min 50°C (120°F) and 1.0 bar absolute (0 psi gauge) Inlet**

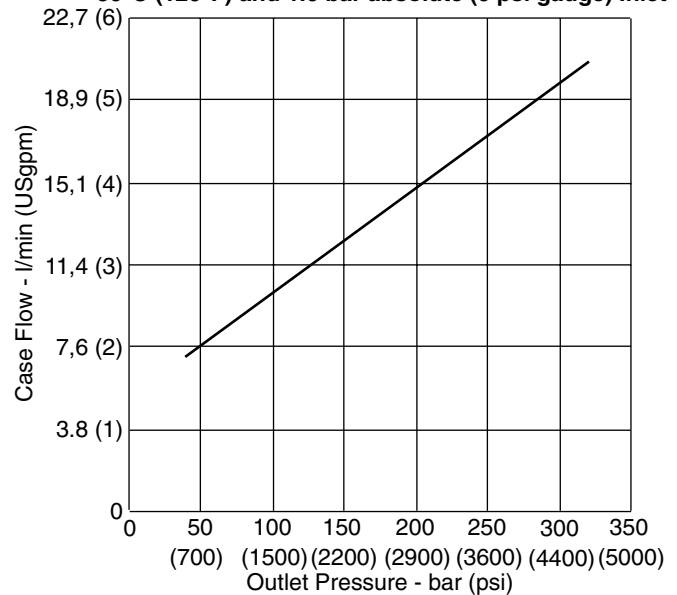



# Performance

Mobile PVM141

**Typical Noise Levels at 2000 and 1000 r/min with Petroleum Oil (10W) at 93°C (200°F), and 1.0 bar absolute (0 psi gauge) Inlet**

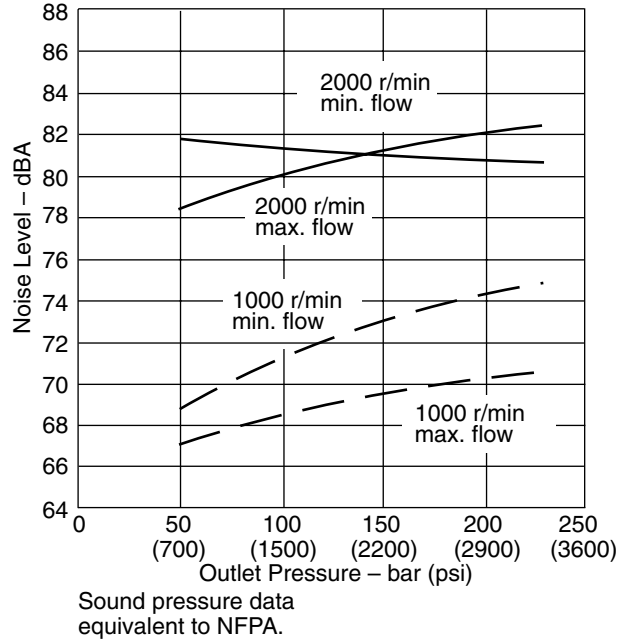

**Overall Efficiency versus Speed at 93°C (200°F), and 1.0 bar absolute (0 psi gauge) Inlet**

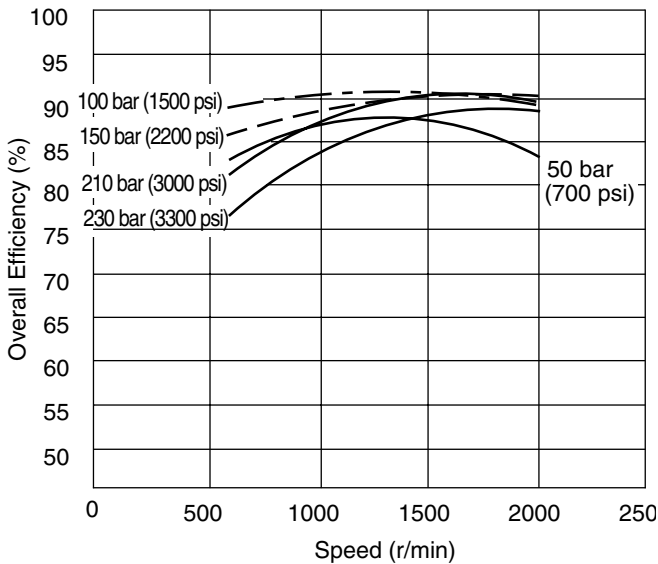

**Delivery and Case Flow versus Speed at 93°C (200°F), Full Flow and 1.0 bar absolute (0 psi gauge) Inlet**

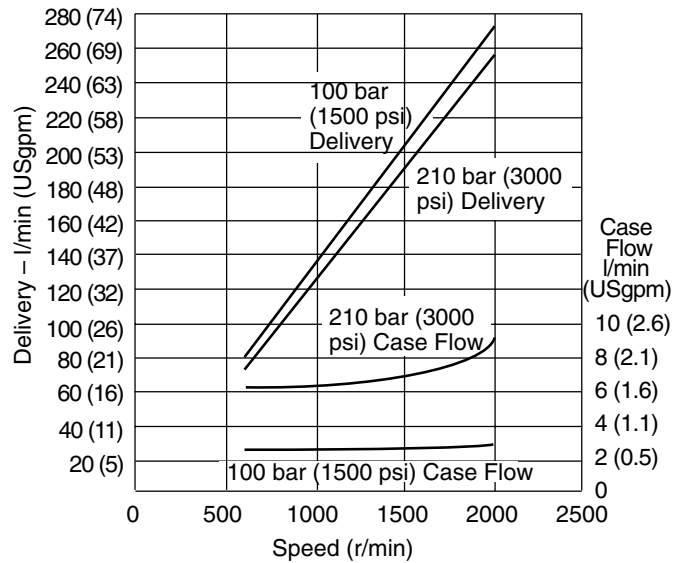

# Performance

Mobile PVM141

**Input Torque versus Speed at 93°C (200°F), Full Flow and 1.0 bar absolute (0 psi gauge) Inlet**

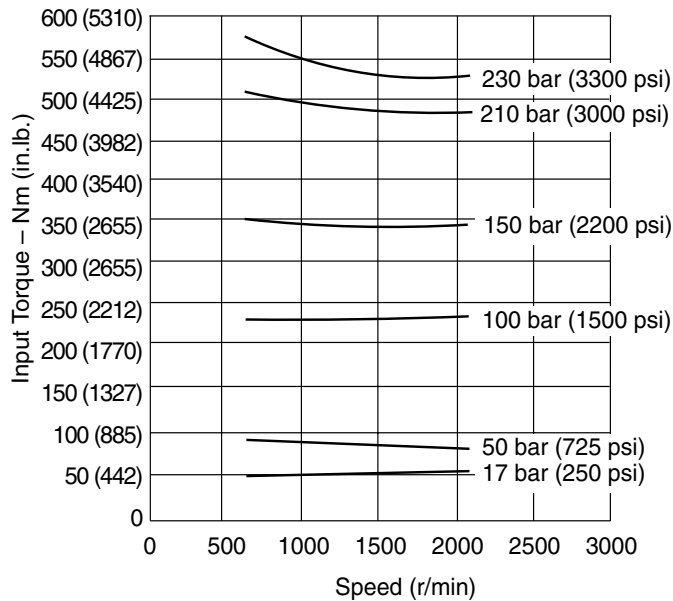

**Input Power versus Speed, 93°C (200°F), and 1.0 bar absolute (0 psi gauge) Inlet**

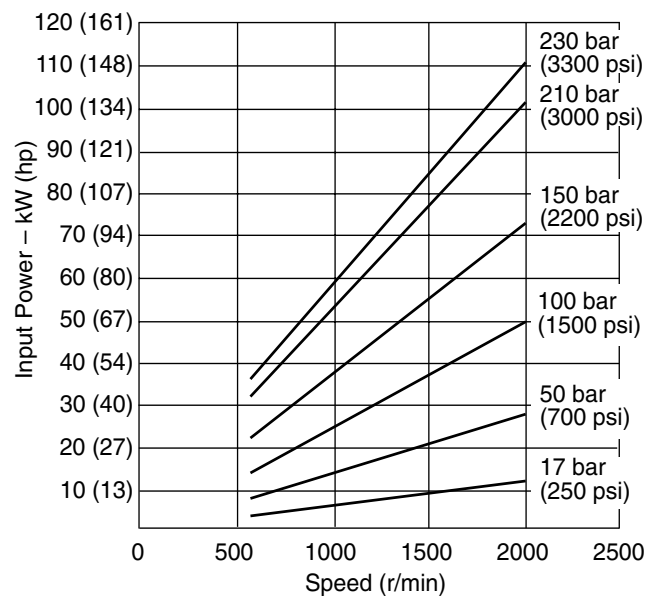

**Input Torque and Case Flow versus Speed at 93°C (200°F), Load Sense Standby and 1.0 bar absolute (0 psi gauge) Inlet**

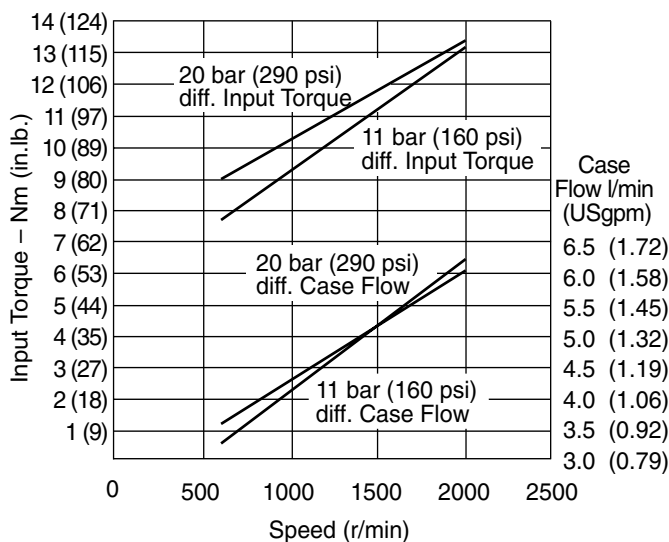

**Input Torque and Case Flow versus Speed at 93°C (200°F), Pressure Limit Cut-Off and 1.0 bar absolute (0 psi gauge) Inlet**

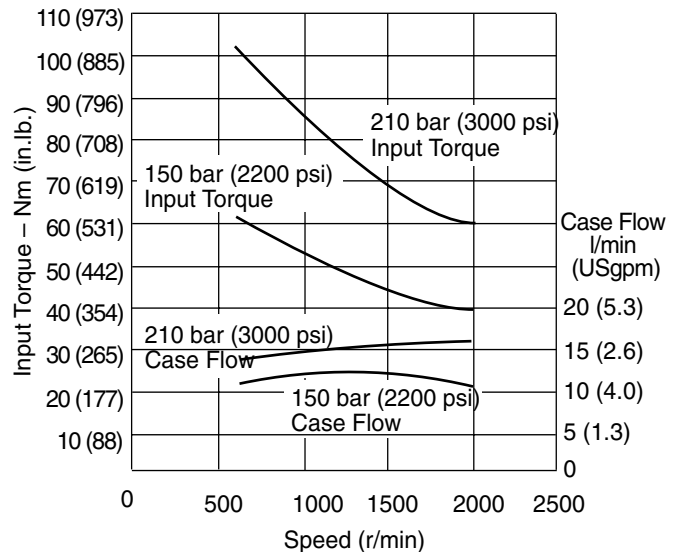

# End-ported Models

PVM018/020

Dimensions in millimeters (inches)

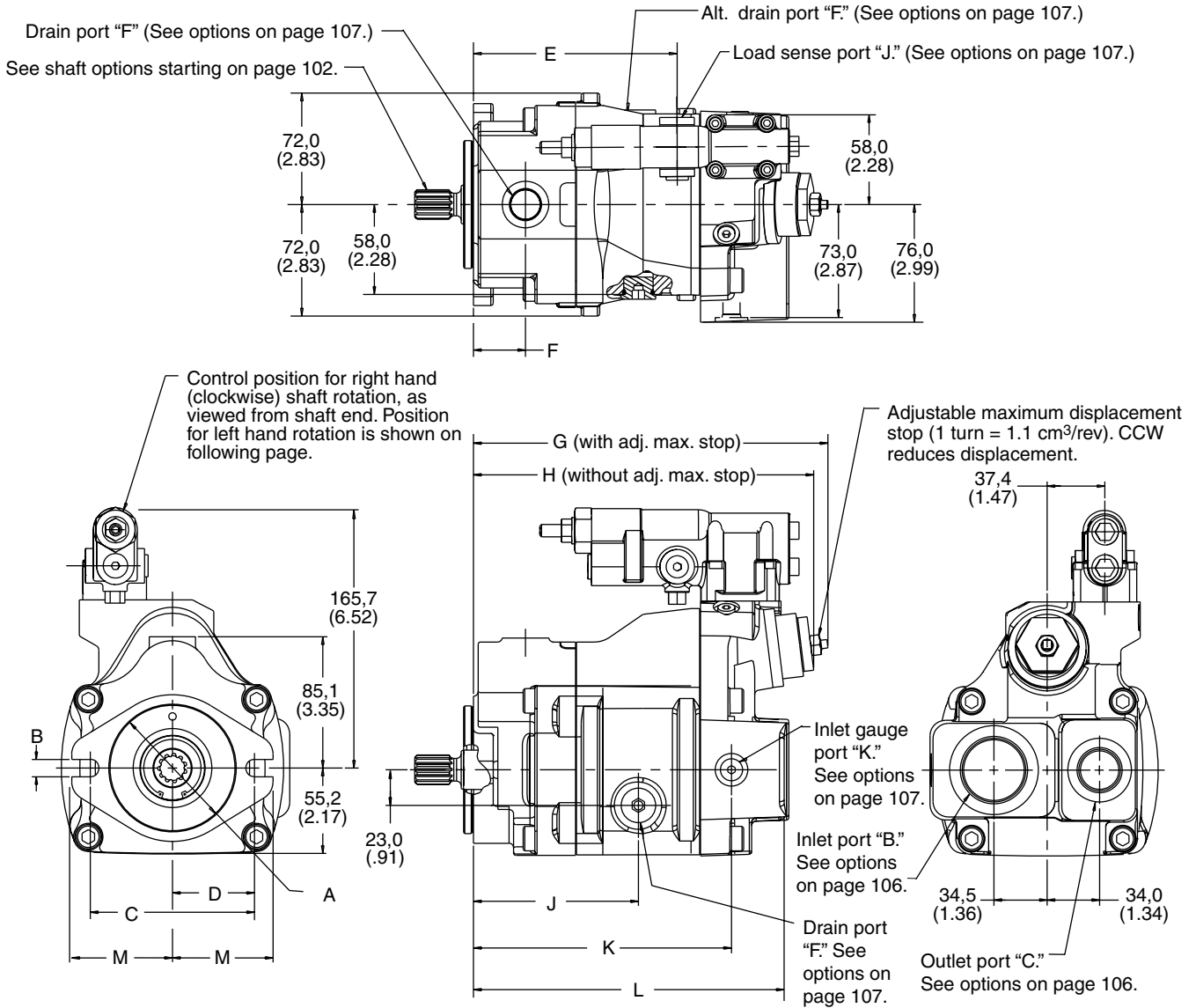

# End-ported Models

PVM018/020

Dimensions in millimeters (inches)

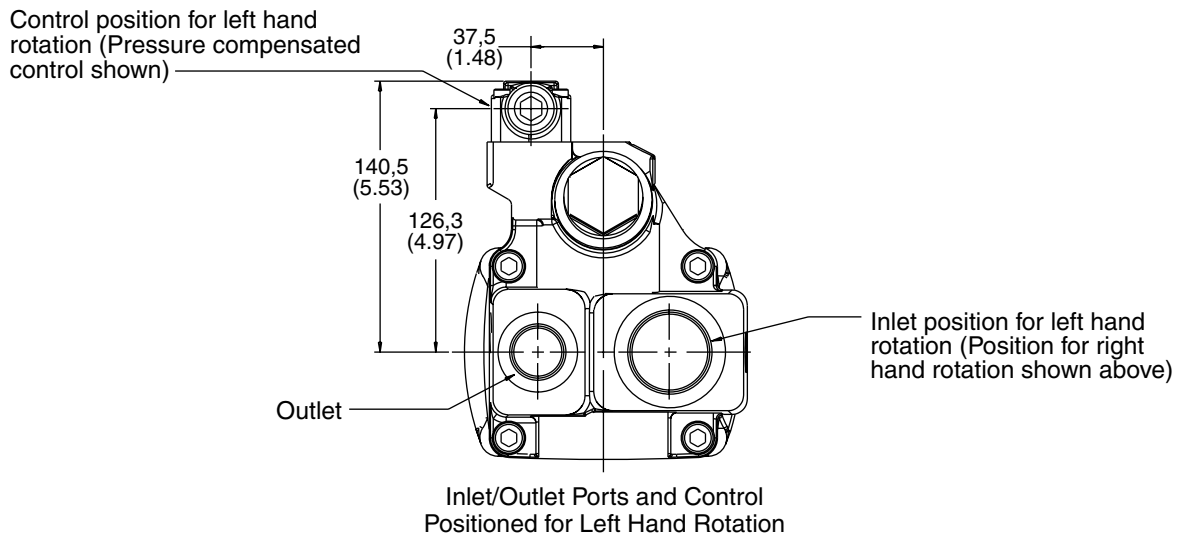
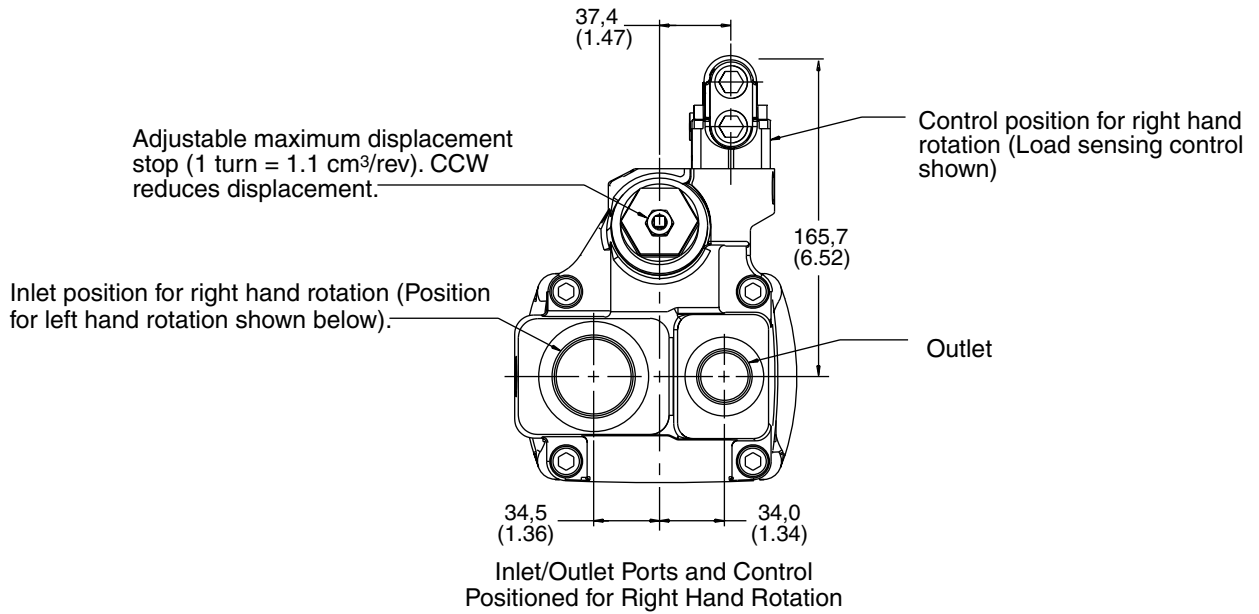

# Side-ported Models

PVM018/020

Dimensions in millimeters (inches)

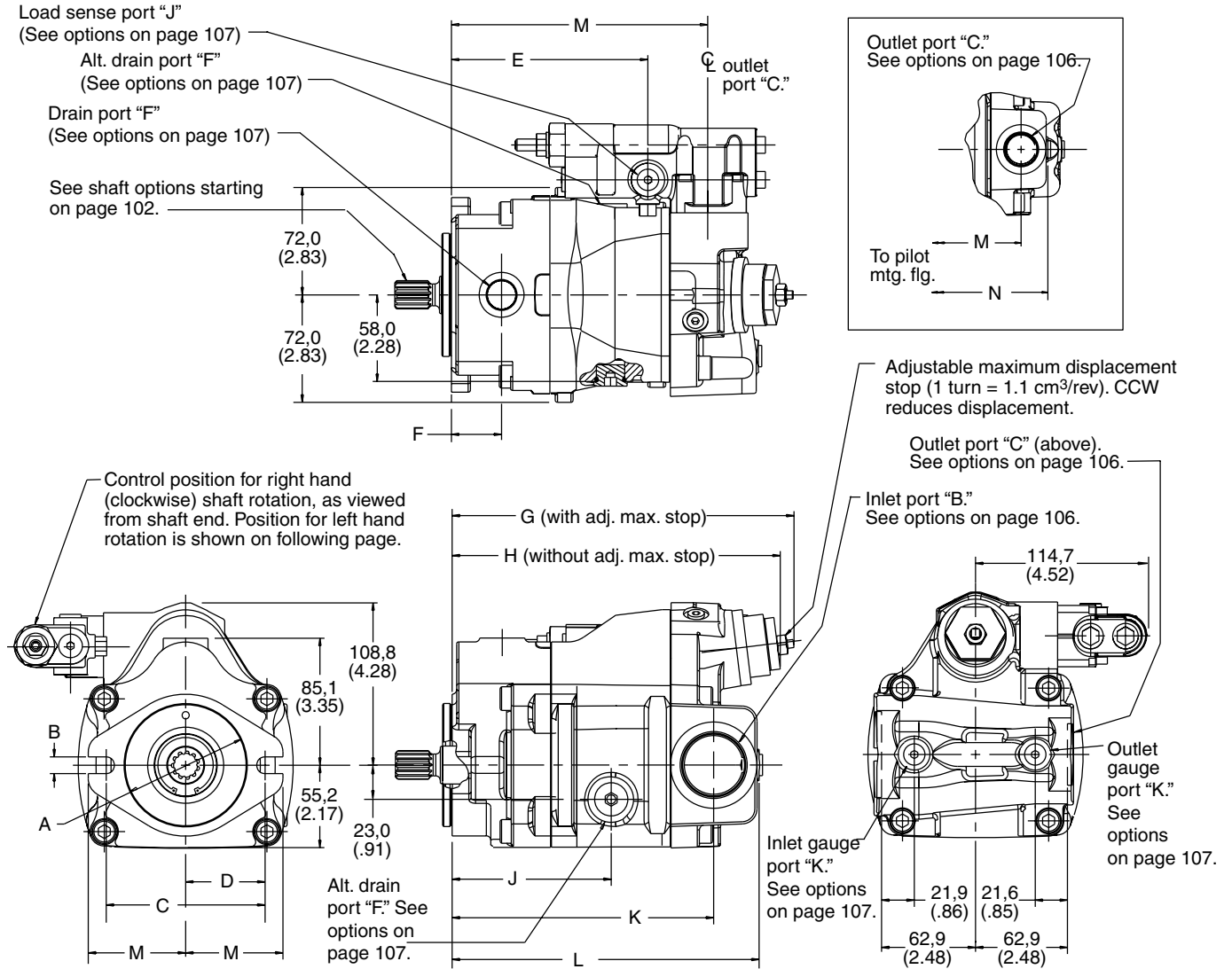

# Side-ported Models

PVM018/020

Dimensions in millimeters (inches)

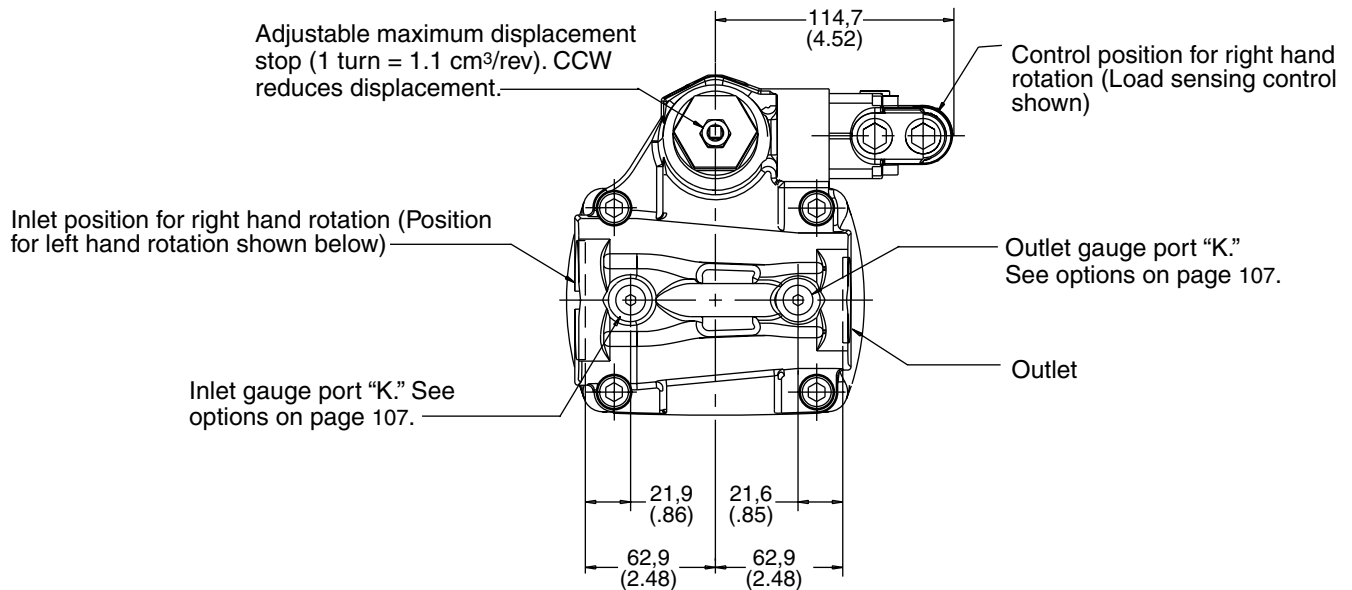

Inlet/Outlet Ports and Control Positioned for Right Hand Rotation

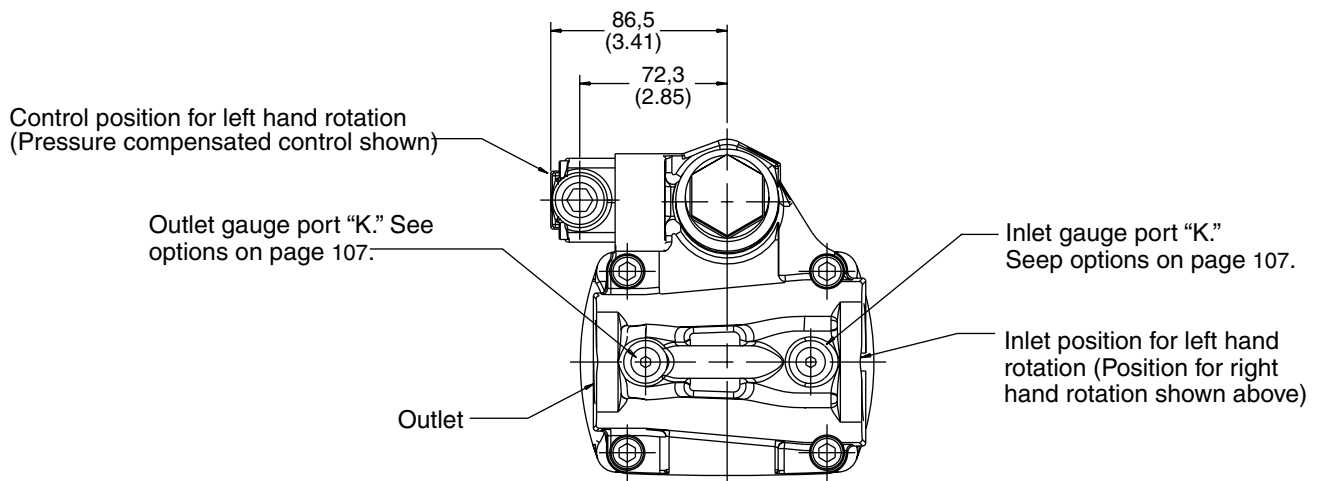

Inlet/Outlet Ports and Control Positioned for Left Hand Rotation

# Thru-drive Models

PVM018/020

## Dimensions in millimeters (inches)

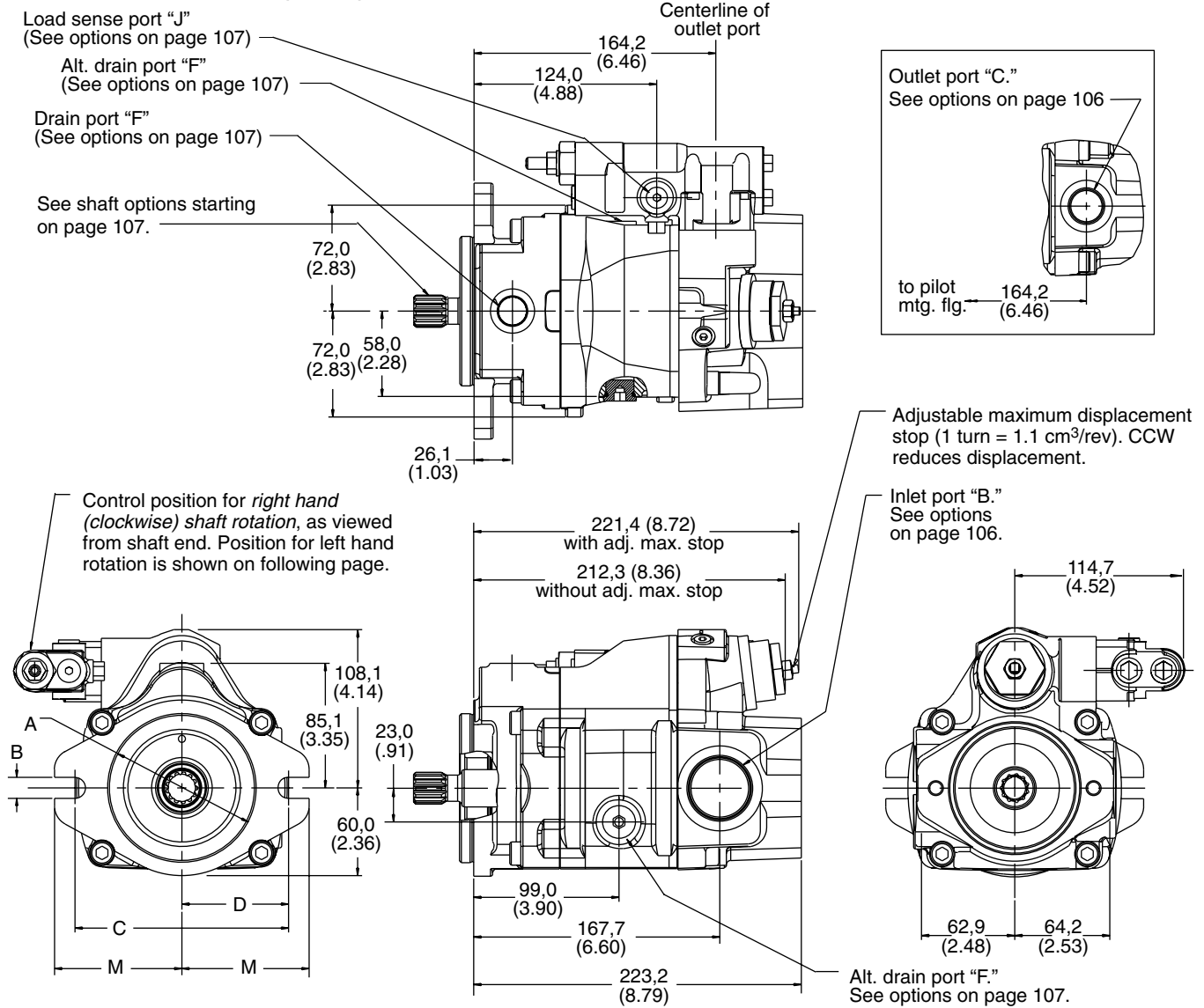

# Thru-drive Models

PVM018/020

## Model Code Position 25

	Description
A	For SAE "A" pad with a 9T, 16/32 DP, 30° pressure angle, involute spline
B	For SAE "A" pad with a 11T, 16/32 DP, 30° pressure angle, involute spline
G	For ISO 80 A2HW pad with a 9T SAE spline
H	For ISO 80 A2HW pad with a 11T SAE spline

### Dimensions in millimeters (inches)

Adjustable maximum displacement stop (1 turn = 1.1 cm<sup>3</sup>/rev). CCW reduces displacement.

Inlet position for *right hand rotation* (Position for left hand rotation shown below)

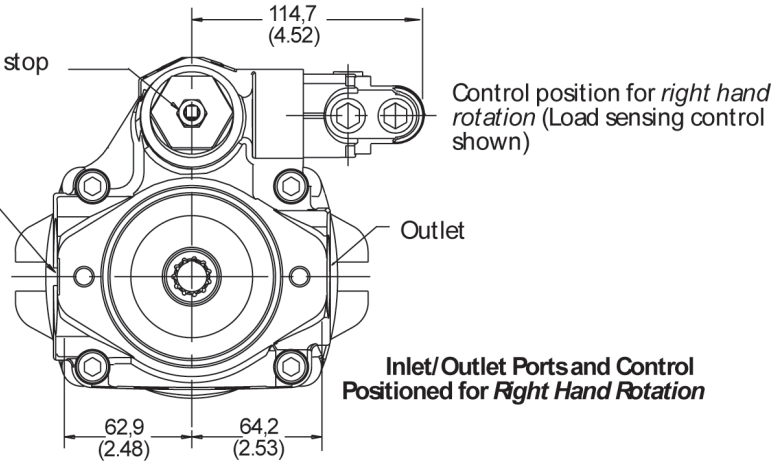

Control position for *left hand rotation* (Pressure compensator control shown)

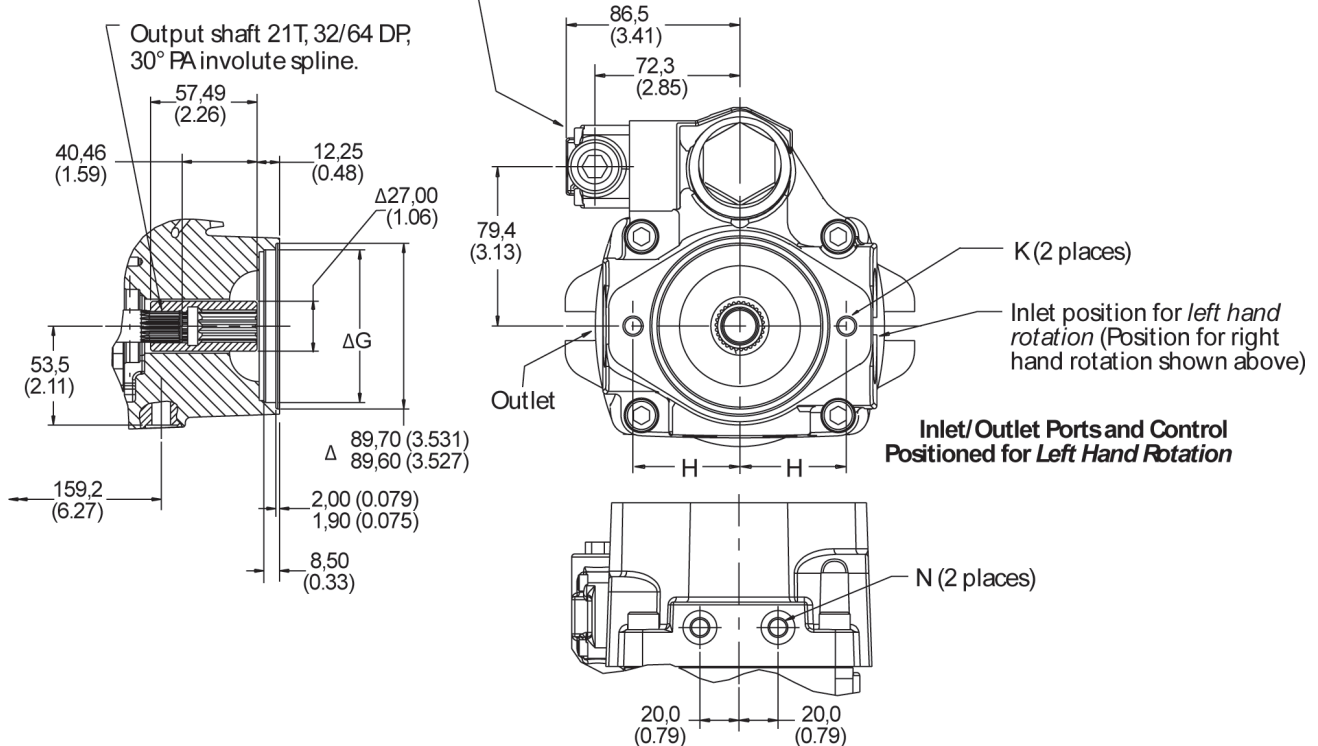

Model Code Position 25	ØG	H	K	N
A,B	82,625 (3.253) 82,575 (3.251)	53,2 (2.09)	375-16 UNC-2B thd. 0.75 deep min	375-16 UNC-2B thd. 0.62 deep min.
G,H	80,046 (3.151) 80,002 (3.150)	54,5 (2.15)	M10 x 1,50 thd. 19,05 deep min	M10 x 1,50 thd. 15,88 deep min.



# Flange Designations

PVM018/020

<b>"A" Pilot Flange Designation</b>	<b>ØA</b>	<b>B</b>	<b>C</b>	<b>D</b>	<b>E</b>	<b>F</b>	<b>G</b>	<b>H</b>	<b>J</b>	<b>K</b>	<b>L</b>	<b>M</b>
SAE J744-82-2 Model Code A	82,55 (3.25)	11,35/10,97 (.447/.432)	106,4 (4.19)	53,2 (2.09)	131,5 (5.18)	33,6 (1.32)	228,9 (9.00)	219,8 (8.65)	106,5 (4.19)	166,7 (6.56)	200,7 (7.90)	65,2 (2.57)
ISO 3019/2-80A2HW Model Code B	80,00 (3.15)	11,27/11,00 (.444/.433)	109,0 (4.29)	54,5 (2.15)								

<b>"B" Pilot Flange Designation</b>	<b>ØA</b>	<b>B</b>	<b>C</b>	<b>D</b>	<b>E</b>	<b>F</b>	<b>G</b>	<b>H</b>	<b>J</b>	<b>K</b>	<b>L</b>	<b>M</b>
SAE J744-101-2 Model Code C	101,60 (4.00)	14,55/14,17 (.572/.557)	146,0 (5.750)	73,0 (2.875)	124,0 (4.88)	26,1 (1.03)	221,4 (8.72)	212,3 (8.36)	99,0 (3.90)	159,2 (6.27)	193,9 (7.63)	87,0 (3.43)
ISO 3019/2-100A2HW Model Code D	100,00 (3.937)	14,27/14,00 (.562/.551)	140,0 (5.512)	70,0 (2.756)								

<b>Pilot Flange Designation</b>	<b>ØA</b>	<b>B</b>	<b>C</b>	<b>D</b>
SAE J744-127-2 Model Code C	101,60 (4.00)	14,55/14,17 (.572/.558)	146,0 (5.75)	73,0 (2.87)
ISO 3019/2-100 A2HW Model Code D	100,00 (3.94)	14,27/14,00 (.562/.551)	140,0 (5.51)	70,0 (2.76)

# End-ported Models

PVM045/050

## Dimensions in millimeters (inches)

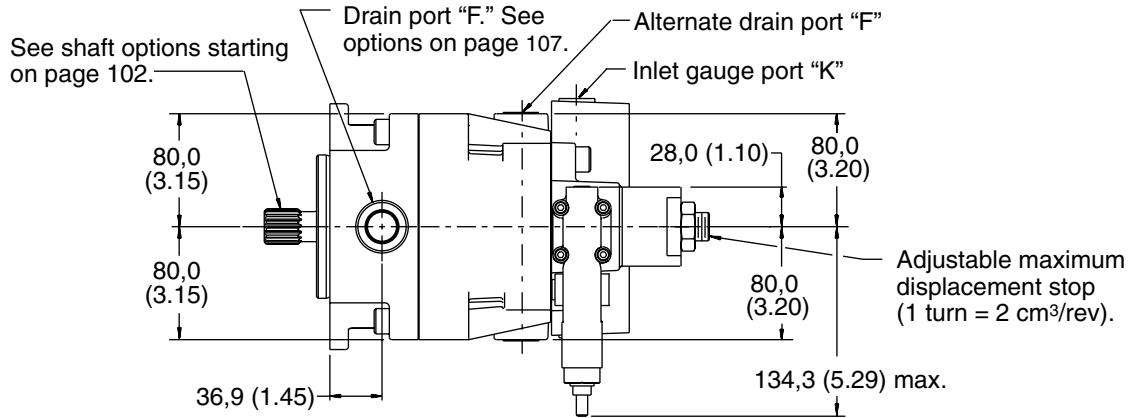

Control position for *left hand (counterclockwise) shaft rotation*, as viewed from shaft end. Position for right hand rotation is shown on following page.

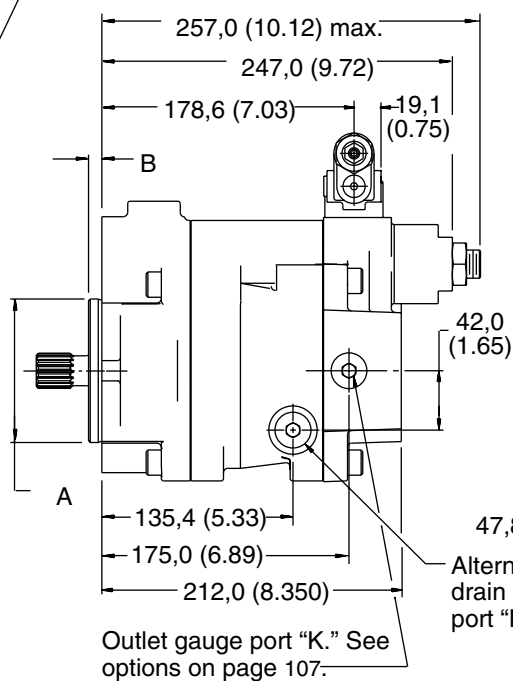
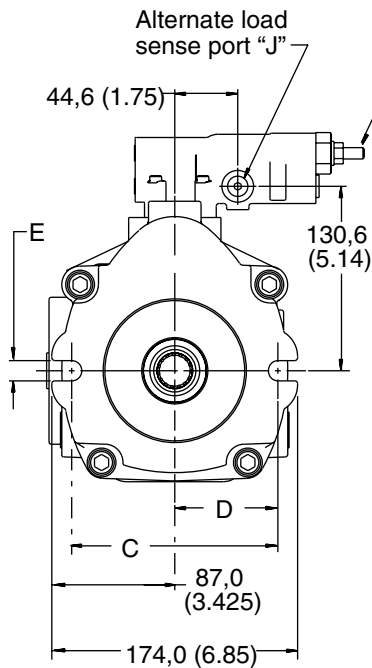

Load sensing control (See pressure compensated control on following page.)

Load sense port "J." See options on page 107.

Inlet port "B." See options on page 106.

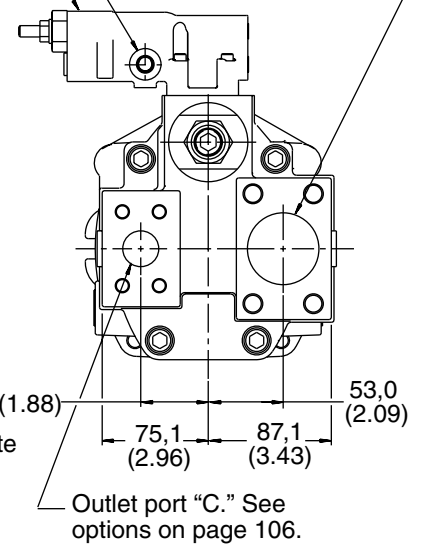

# End-ported Models

PVM045/050

## Dimensions in millimeters (inches)

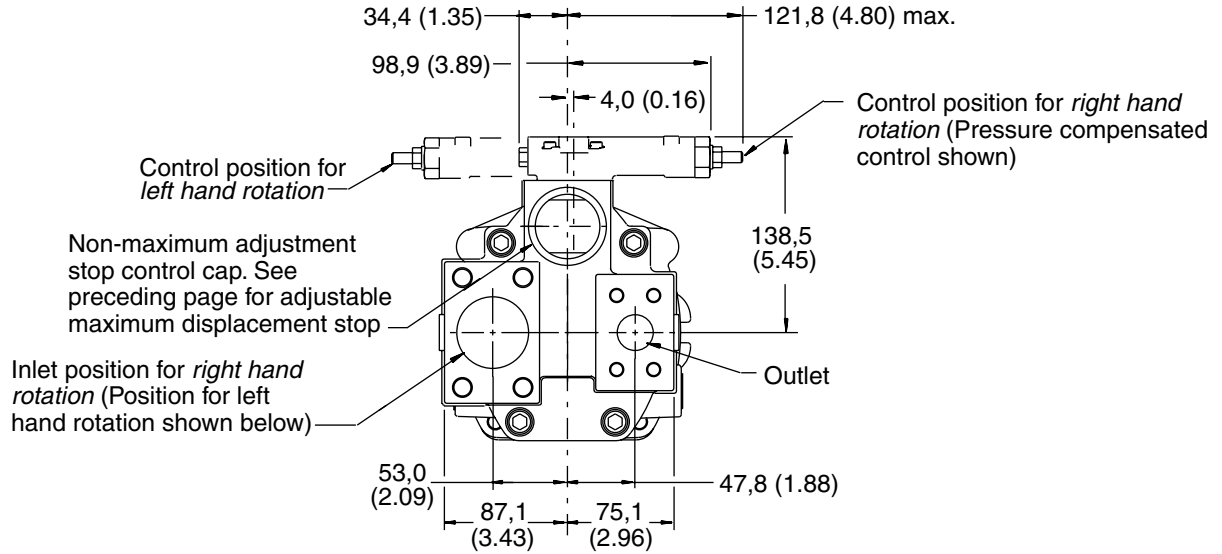

**Inlet/Outlet Ports and Control Positioned for Right Hand Rotation**

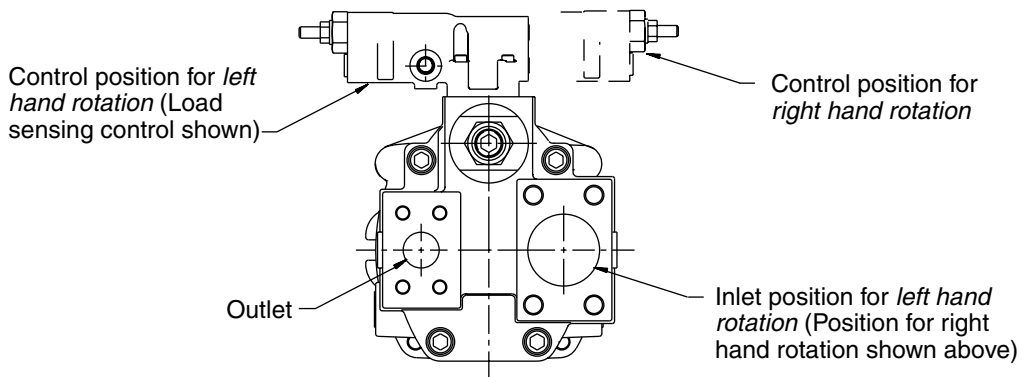

**Inlet/Outlet Ports and Control Positioned for Left Hand Rotation**

Dimensions shown on preceding page.

# Side-ported Models

PVM045/050

## Dimensions in millimeters (inches)

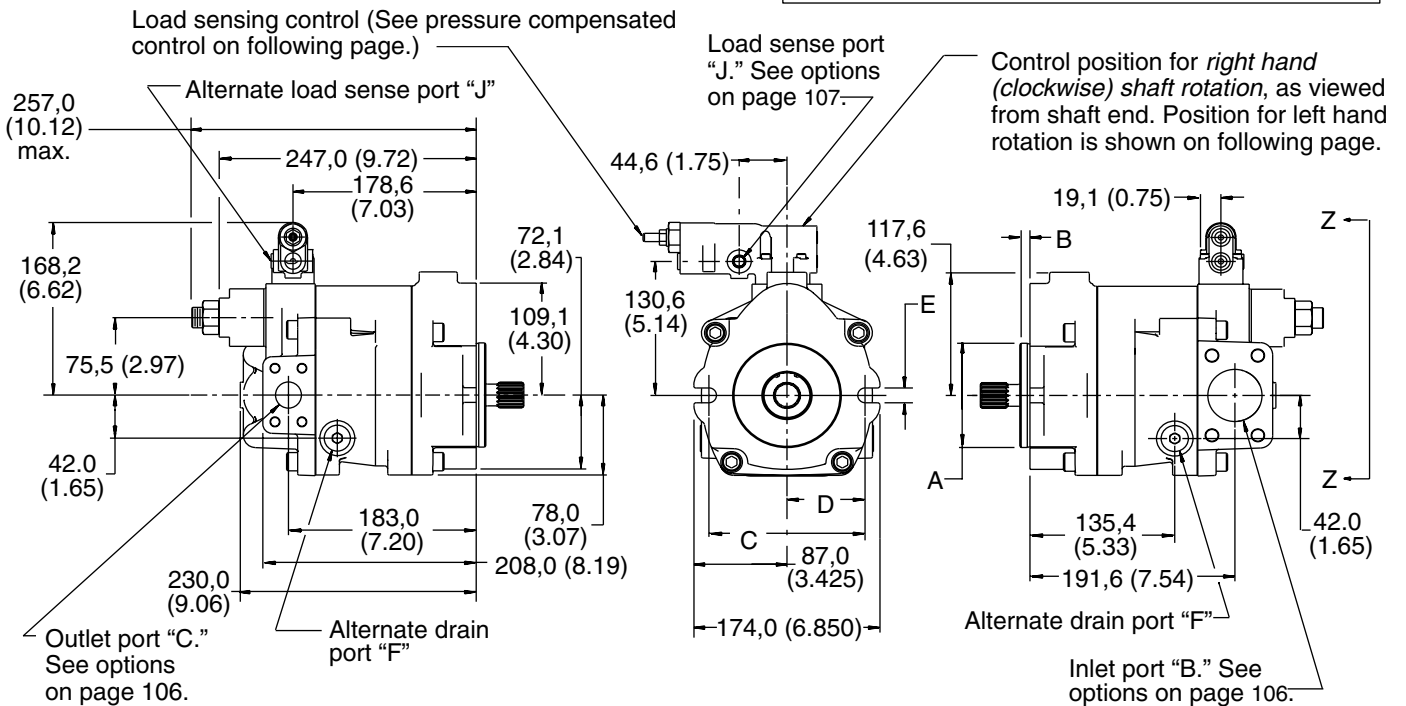
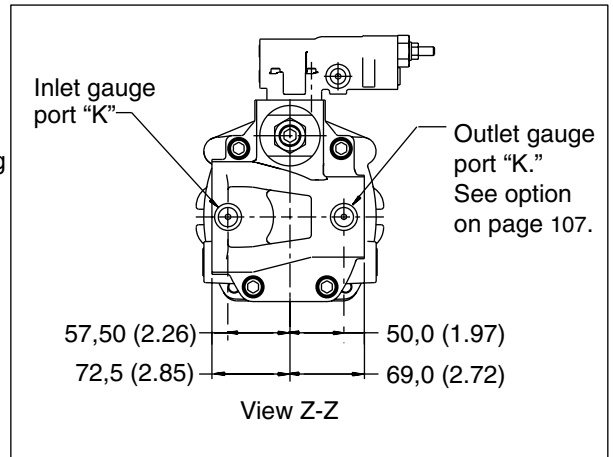
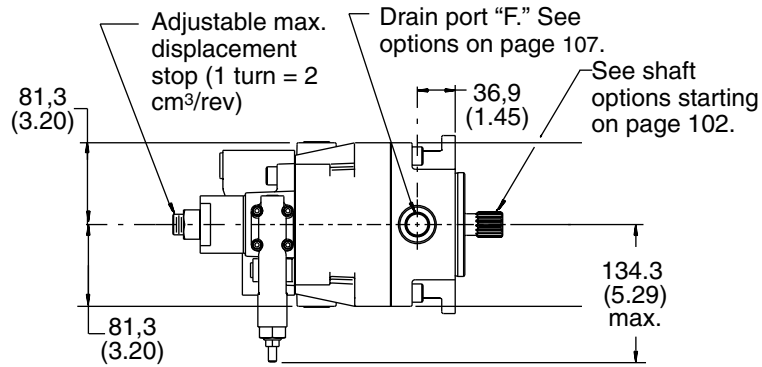

# Side-ported Models

PVM045/050

## Dimensions in millimeters (inches)

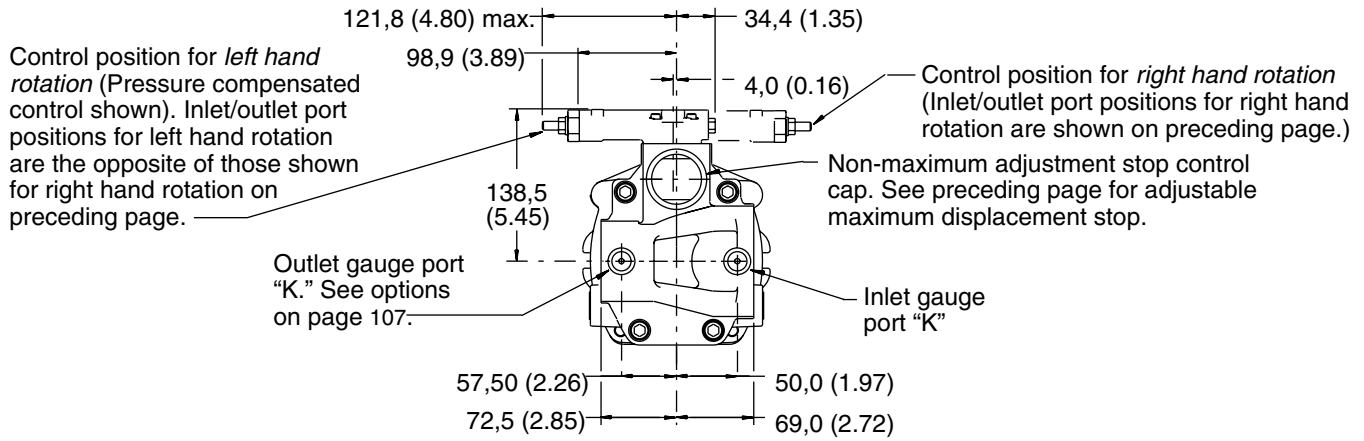

**Inlet/Outlet Ports and Control Positioned for Left Hand Rotation**

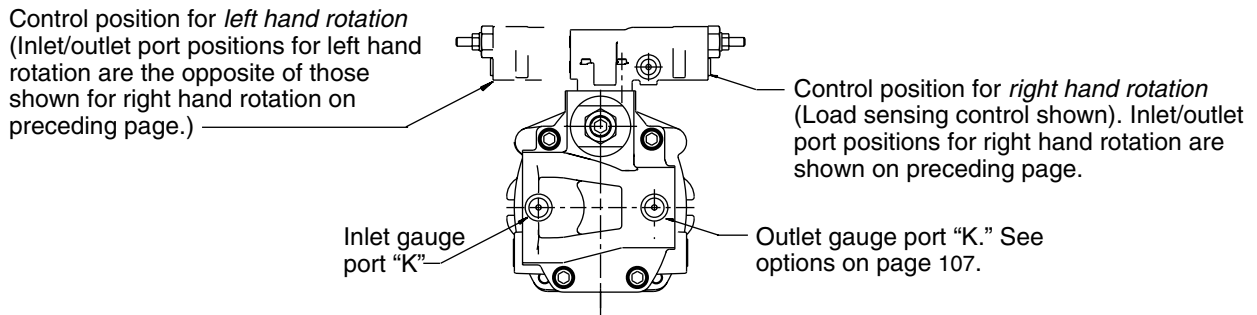

**Inlet/Outlet Ports and Control Positioned for Right Hand Rotation**

Dimensions shown on preceding page.

# Thru-drive Models

PVM045/050

## Dimensions in millimeters (inches)

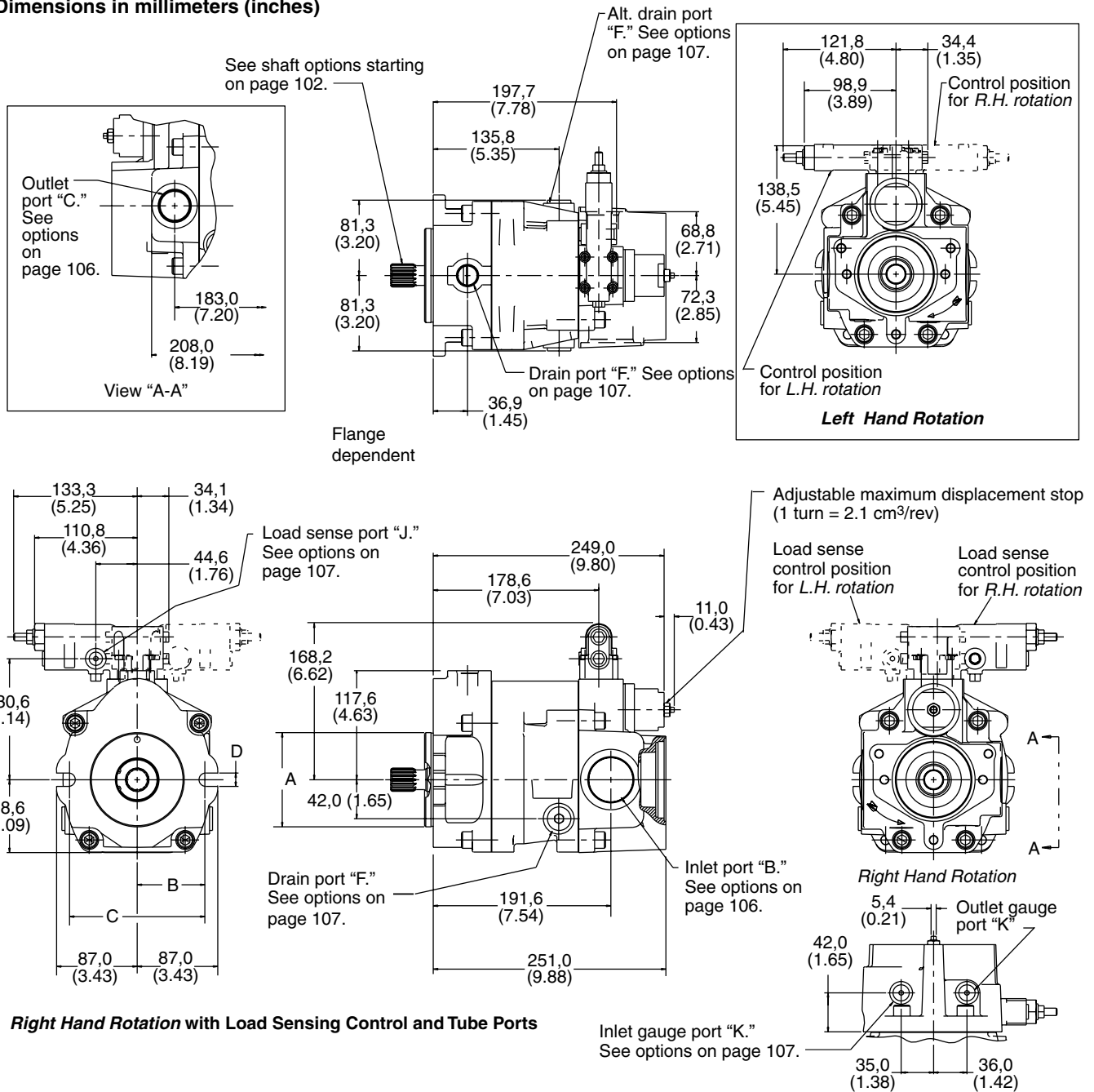

# Thru-drive Models

PVM045/050

## Dimensions in millimeters (inches)

### "A" Pad

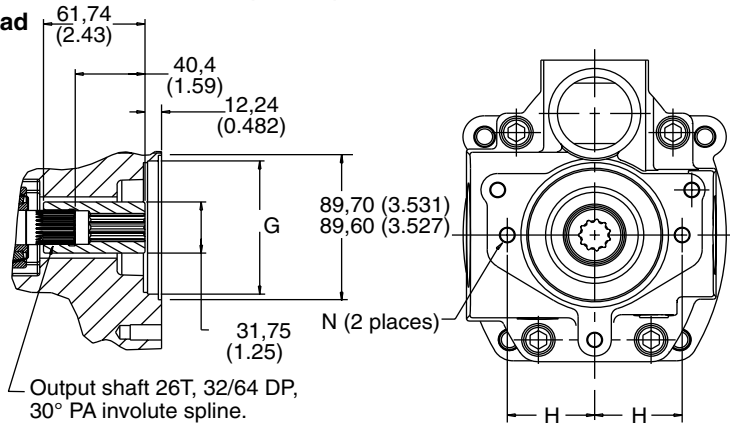

### "B" Pad

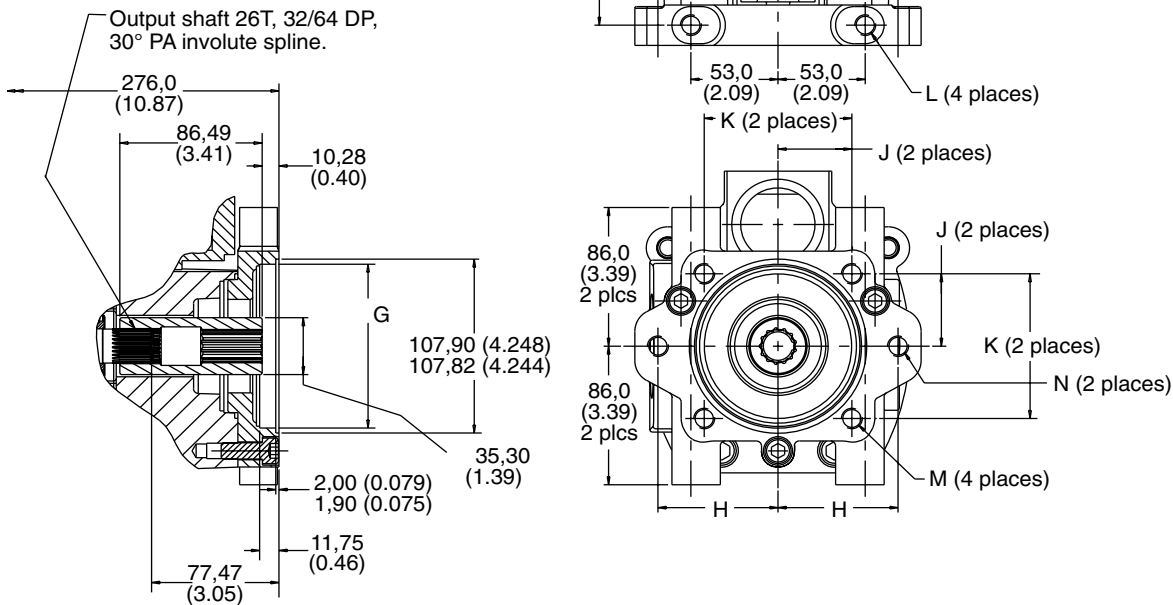

## Model Code Position 25

	Description
A	For SAE "A" pad with a 9T, 16/32 DP, 30° pressure angle, involute spline
B	For SAE "A" pad with a 11T, 16/32 DP, 30° pressure angle, involute spline
C	For SAE "B" pad with a 13T, 16/32 DP, 30° pressure angle, involute spline
D	For SAE "B" pad with a 15T, 16/32 DP, 30° pressure angle, involute spline
G	For ISO 80-A2HW pad with a 9T SAE spline
H	For ISO 80-A2HW pad with a 11T SAE spline
J	For ISO 100-A2/B4HW pad with a 13T SAE spline

Model Code Position 25	ØG	H	J	K	L	M	N
A,B	82,58 (3.251) 82,52 (3.249)	53,2 (2.09)	-	-	-	-	.375-16 UNC-2B thd. 0.60 deep min.
G,H	80,046 (3.15) 80,002 (3.149)	54,5 (2.15)	-	-	-	-	M10 thd. x 1,50 15,0 deep min.
C,D	101,65 (4.002) 101,60 (4.00)	73,0 (2.87)	44,9 (1.77)	89,8 (3.54)	.500-13 UNC-2B thd. 24,9 deep min. M12 x 1,50 thd. 24,9 deep min.	.500-13 UNC-2B thd. thru M10 x 1,50 thd. thru	.500-13 UNC-2B thd. thru M12 x 1,50 thd. thru
J,K	100,0 (3.937) 99,946 (3.935)	70,0 (2.76)	44,2 (1.74)	88,38 (3.48)	M12 thd. x 1,50 thd. 24,9 deep min.	M10 x 1,50 thd. thru	M12 x 1,50 thd. thru

# Flange Designations

PVM045/050

<b>Pilot Flange Designation</b>	<b>ØA</b>	<b>B</b>	<b>C</b>	<b>D</b>	<b>E</b>
SAE J744-101-2	101,60/101,55 (4.000/3.998)	9,70/9,19 (.382/.362)	146,0 (5.750)	73,0 (2.875)	14,55/14,17 (.572/.557)
ISO 3019/2-100A2HW	100,00/99,95 (3.937/3.935)	9,50/9,00 (.374/.354)	140,0 (5.512)	70,0 (2.756)	14,27/14,00 (.562/.551)

<b>Pilot Flange Designation</b>	<b>ØA</b>	<b>B</b>	<b>C</b>	<b>D</b>
SAE 2-bolt mount	101,60/101,55 (4.000/3.998)	73,0 (2.87)	146,0 (5.750)	14,55/14,17 (.572/.557)
ISO 100 2-bolt mount	100,00/99,95 (3.937/3.935)	70,0 (2.76)	140,0 (5.512)	14,27/14,00 (.562/.551)



# End-ported Models

PVM057/063

Dimensions in millimeters (inches)

See mounting flange options on page 101.

See shaft options starting on page 102.

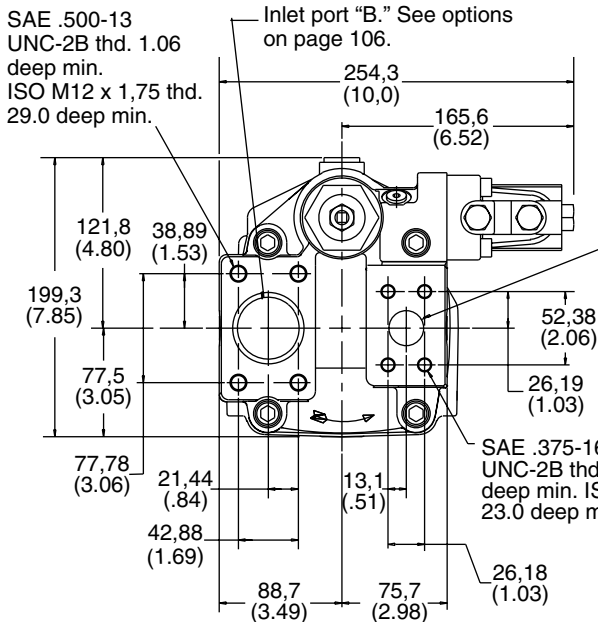
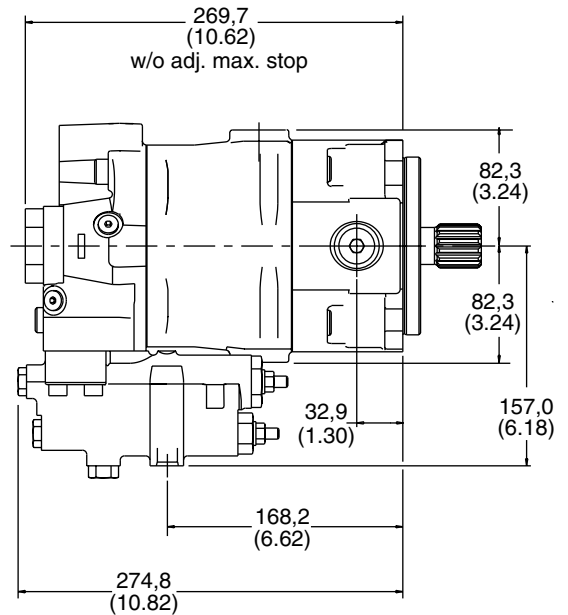
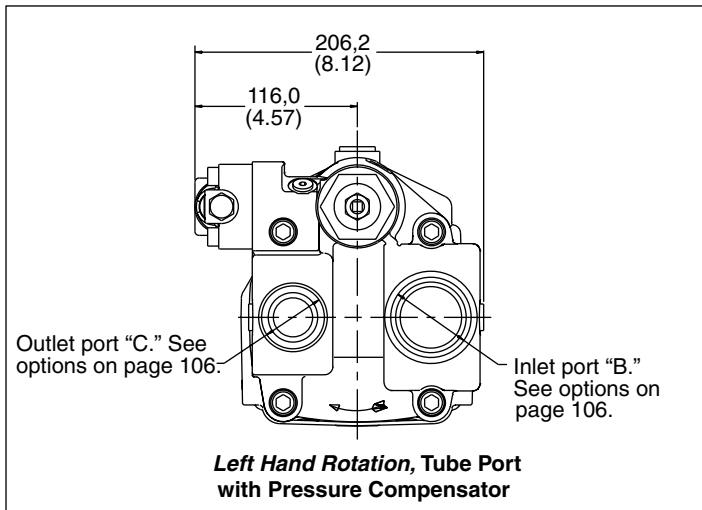

**Right Hand Rotation, Flange Port with Load Sensing Control**

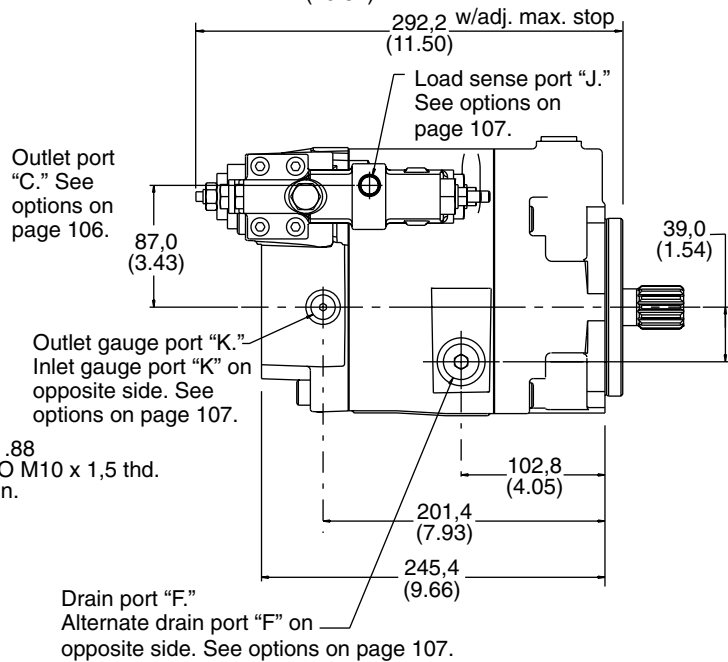

# Side-ported Models

PVM057/063

Dimensions in millimeters (inches)

See mounting flange options on page 101.

See shaft options starting on page 102.

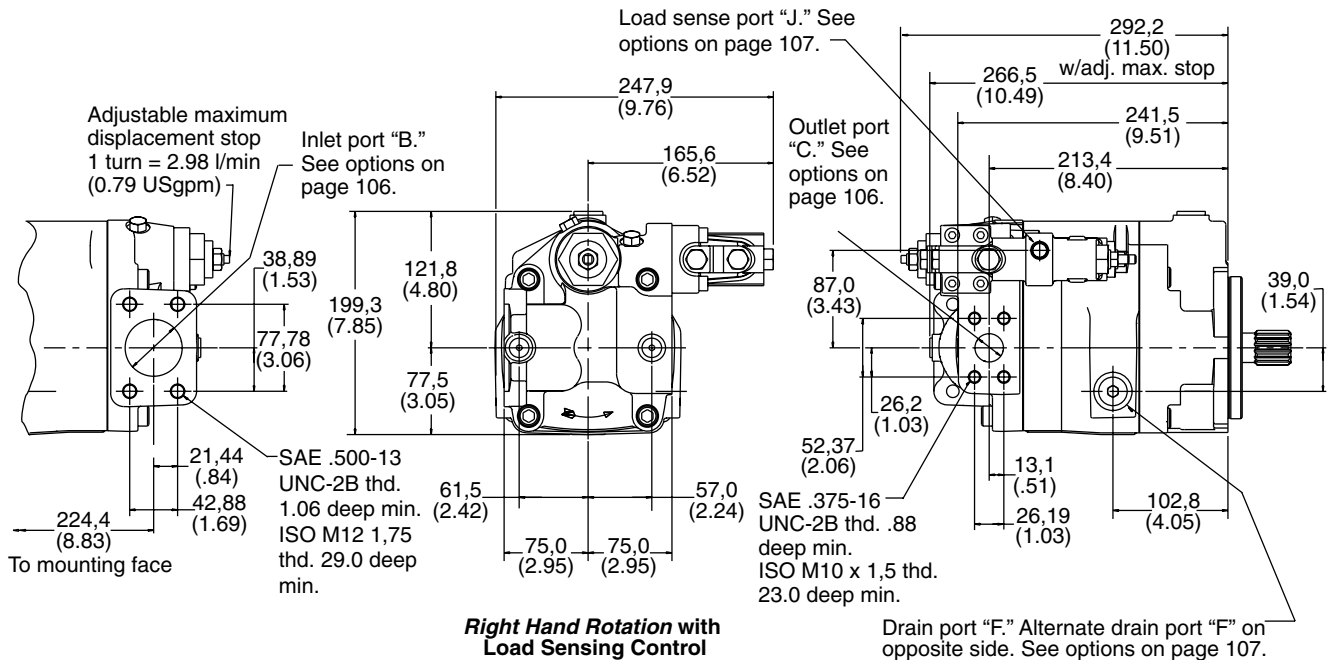
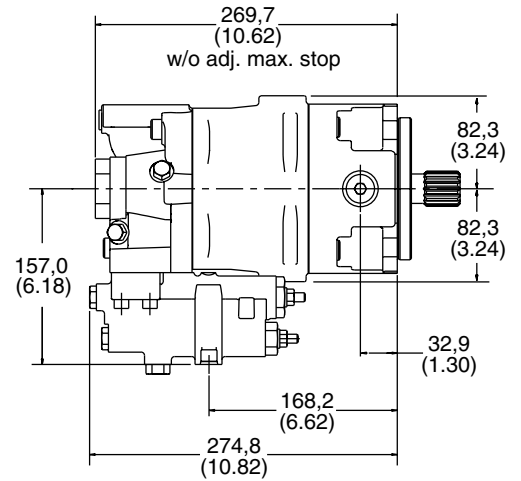
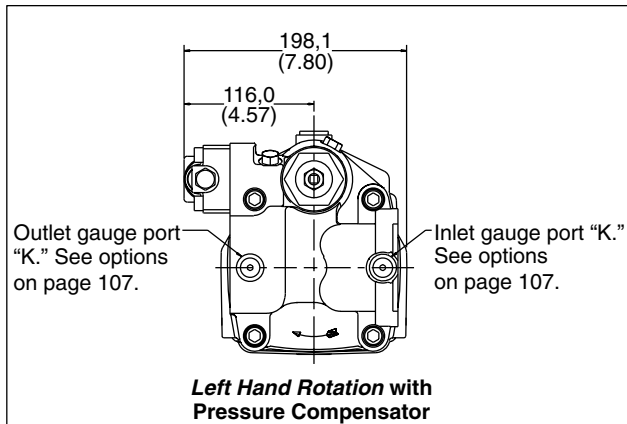

# Thru-drive Models

PVM057/063

**Dimensions in millimeters (inches)**  
**See pilot flange options on page 101.**  
**See shaft options starting on page 102.**

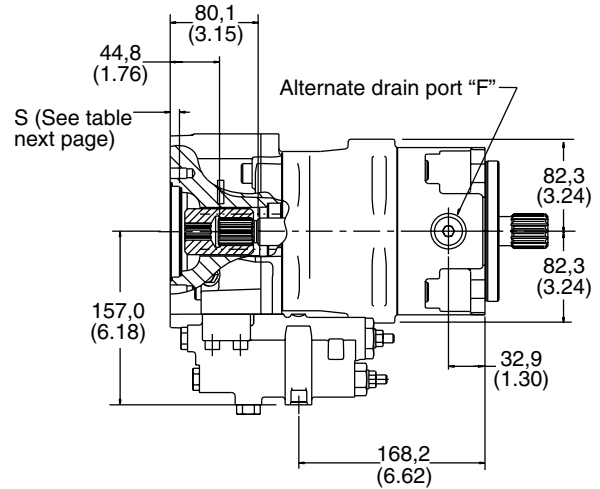
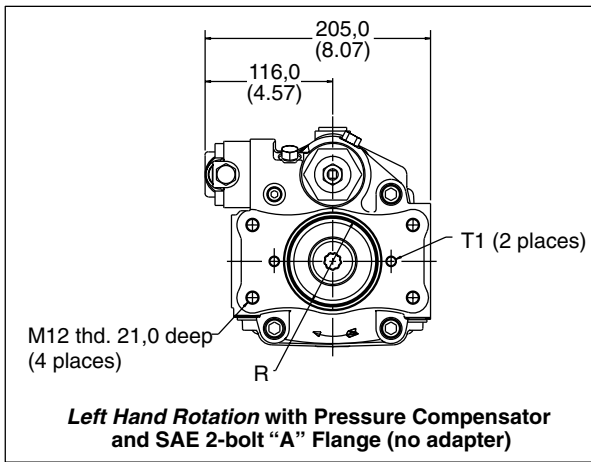

SAE .500-13  
 UNC-2B thd.  
 1.06 deep min.  
 ISO M12 x 1,75 thd.  
 29.0 deep min.

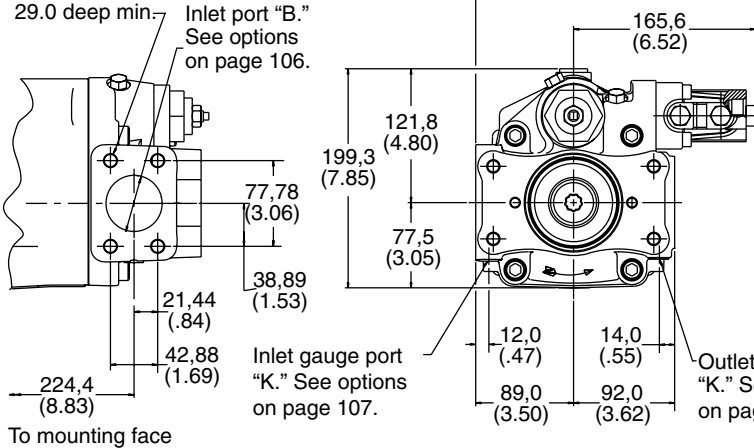

Load sense port "J." See options on page 107.

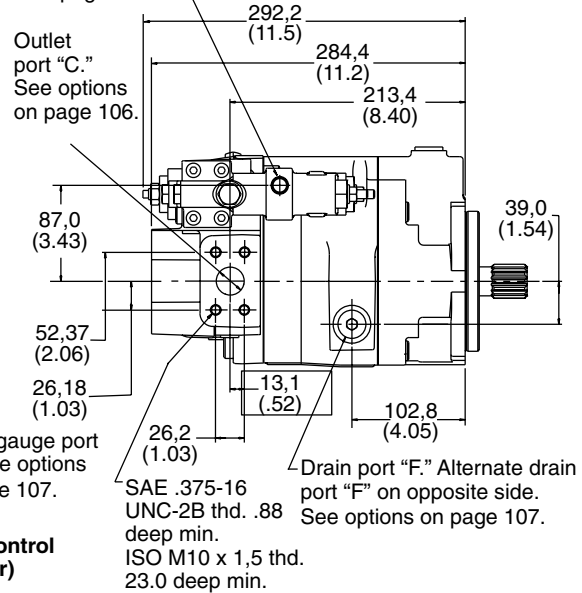

SAE .375-16  
 UNC-2B thd. .88  
 deep min.  
 ISO M10 x 1,5 thd.  
 23.0 deep min.

Drain port "F." Alternate drain port "F" on opposite side. See options on page 107.

# Thru-drive Models

PVM057/063

## Dimensions in millimeters (inches)

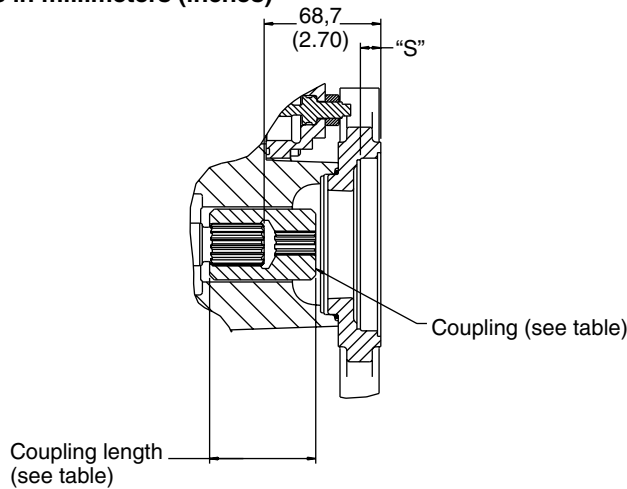

Coupling	Length	Code
SAE "A," 9T	62,5 (2.46)	A,G
SAE "B," 13T	93,0 (3.66)	C,J
SAE "B-B," 15T	93,0 (3.66)	D,K
SAE "C," 14T	93,0 (3.66)	E,L

## "B" Adapter Flange

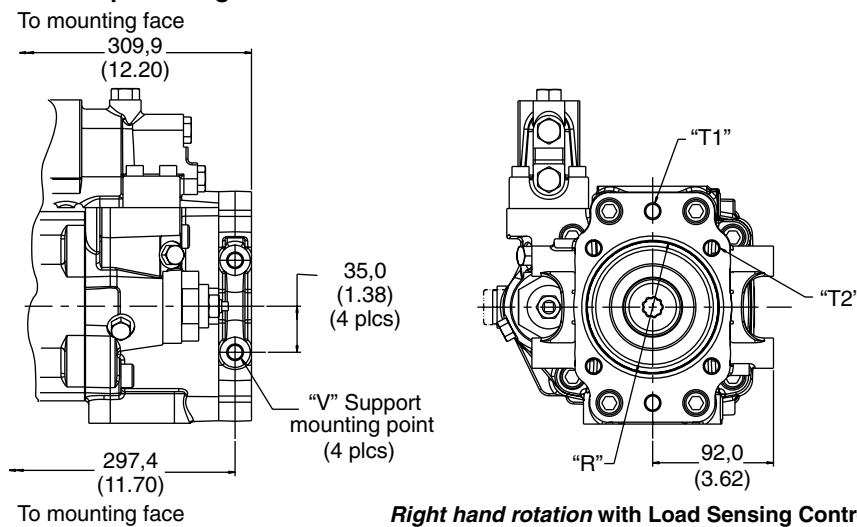

## Model Code Position 25

	Description
A	SAE "A," 9T, 16/32 DP, 30° pressure angle, involute spline
C	SAE "B," 13T, 16/32 DP, 30° pressure angle, involute spline
D	SAE "B-B," 15T, 16/32 DP, 30° pressure angle, involute spline
E	SAE "C," 14T, 12/24 DP, 30° pressure angle, involute spline
G	For ISO 80-A2HW pad with a 9T SAE spline
J	For ISO 100-A2/B4HW pad with a 13T SAE spline
K	For ISO 100-A2/B4HW pad with a 15T SAE spline
L	For ISO 125-A2/B4HW pad with a 14T SAE spline

**Right hand rotation with Load Sensing Control and SAE 2-1/4-bolt "B" adapter flange**

Model Code	Position 25 Flange	Bolt	Pilot Dia. "R"	Pilot Depth "S"	Support Mounting Points "V"	
					2-bolt "T1"	4-bolt "T2"
A,B	SAE "A" 2-bolt	SAE	Ø82,65 (3.25±.001)	8,6/8,1 (.32/.34)	.375-16 UNC-2B thd.	N/A
G,H	ISO 80	ISO	Ø80,05 (3.15)	9,0/8,0 (.35/.31)	M10 thd.	N/A
C,D	SAE "B" 2-1/4-bolt	SAE	Ø101,65 (4.002±.001)	12,5/11,5 (.49/.45)	.50-13 UNC-2B thd.	.50-13 UNC-2B thd. .98" deep
J,K	ISO 100	ISO	Ø100,05 (3.94)	12,5/11,5 (.49/.45)	M12 thd.	M12 thd. x 25,0 deep

# Thru-drive Models

PVM057/063

## Dimensions in millimeters (inches)

### "C" Adapter Flange

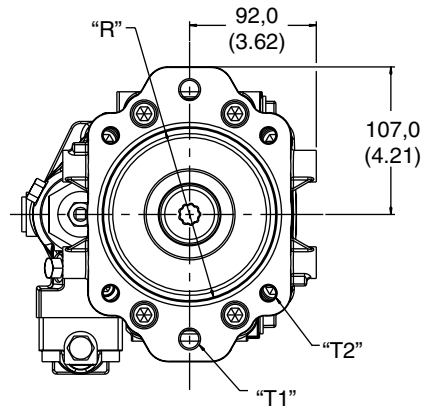
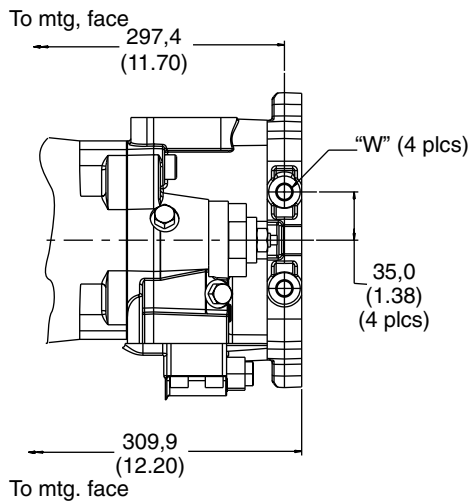

**Left hand rotation with Pressure Compensator and SAE 2-1/4-bolt "C" Adapter Flange**

Model Code	Position 25		Pilot Dia.	Pilot Depth	Support Mounting Points		
	Flange	Bolt			"R"	"S"	2-bolt "T1"
E,F	SAE "C" 2-1/4-bolt	SAE	Ø127,05 (5.002±.001)	15,5/14,5 (.61/.57)	.625-11 UNC-2B thd.	.50-13 UNC-2B thd.	.50-13 UNC-2B thd. .98" deep
L,M	ISO 125	ISO	Ø125,05 (4.92)	15,5/14,5 (.61/.57)	M16 thd.	M12 thd.	M12 thd. x 25,0 deep

# Side-ported Models

PVM074/081

\*Right Hand Only

## Dimensions in millimeters (inches)

See pilot flange options on page 101.  
See shaft options starting on page 102.

Lifting point .375-16 UNC thd.  
10,0 (.39) deep with SAE drain  
M10 thd. 10,0 (.39) deep with ISO drain

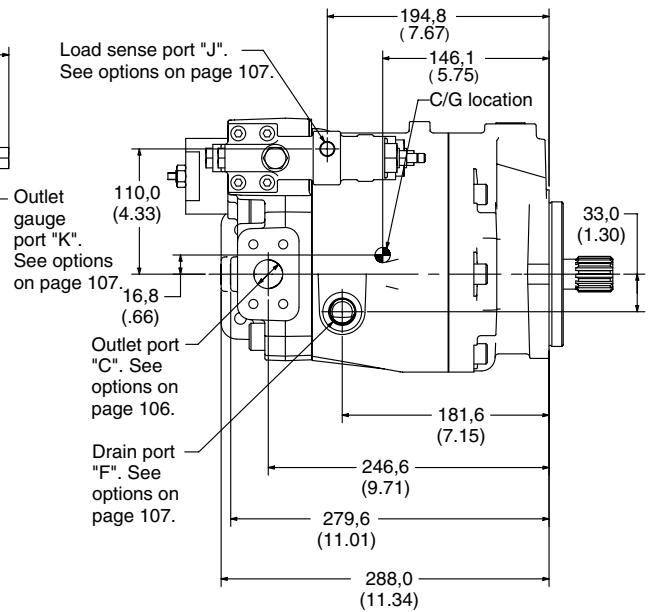
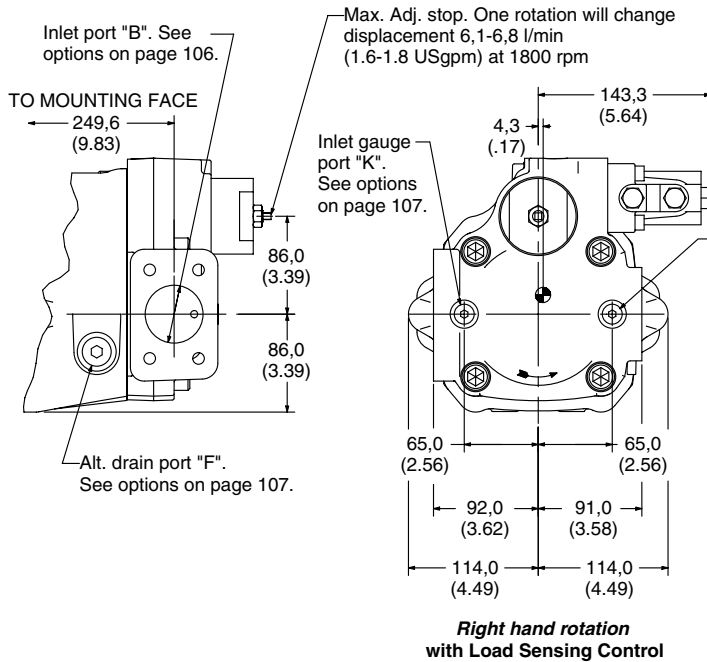
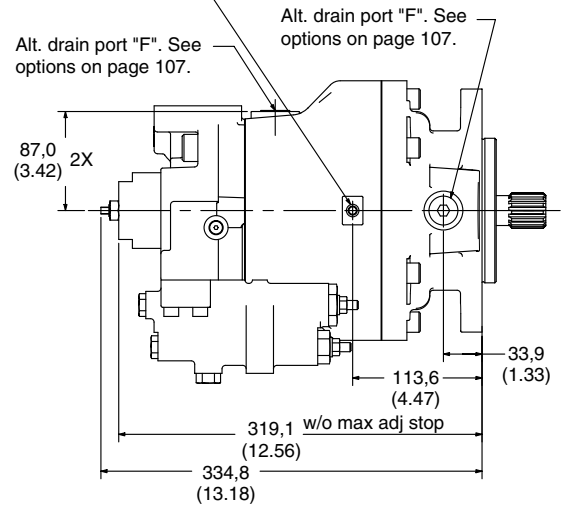
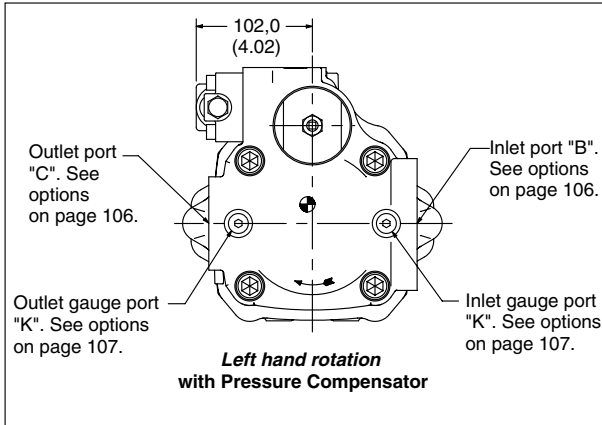

PVM074/108 is not available with left hand rotation in any port configuration.

# Thru-drive Models

PVM074/081

\*Right-hand only

## Dimensions in millimeters (inches)

See pilot flange options on page 101.  
See shaft options starting on page 102.

Lifting point .375-16 UNC thd.  
10,0 (.39) deep with SAE drain  
M10 thd. 10,0 (.39) deep with ISO drain

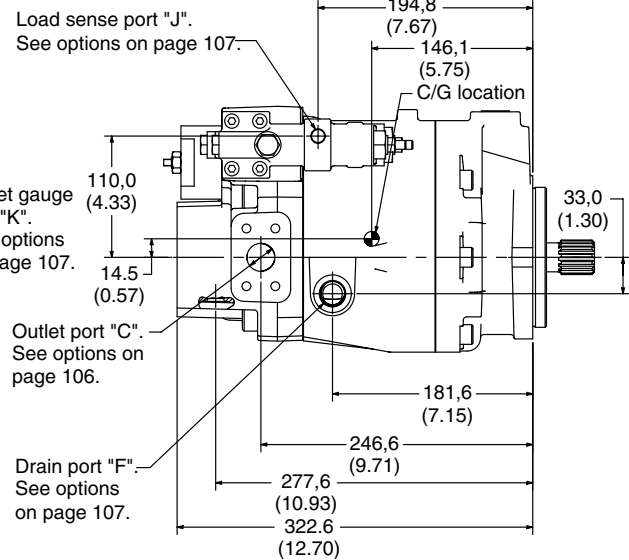
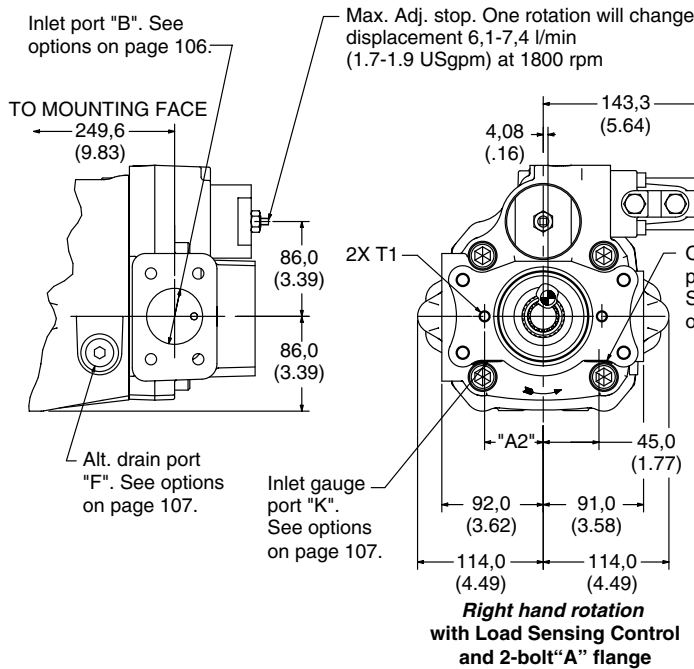
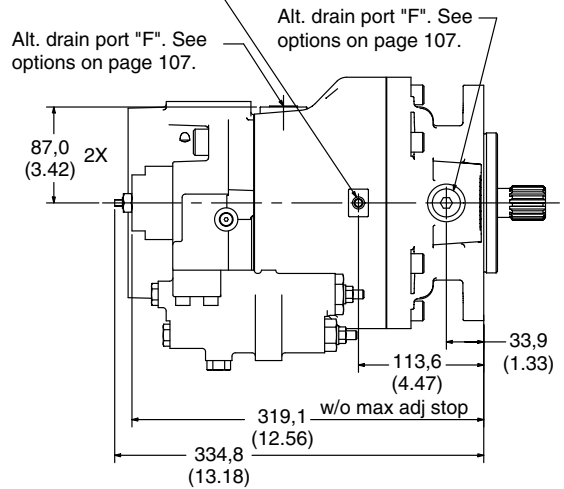
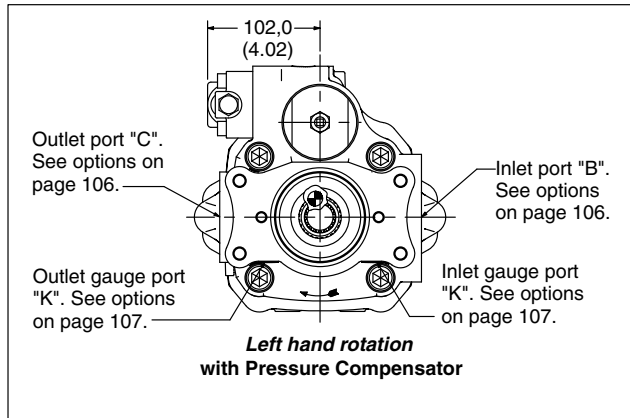

PVM074/108 is not available with left hand rotation in any port configuration.

# Thru-drive Models

PVM074/081

\*Right-hand only

## Dimensions in millimeters (inches)

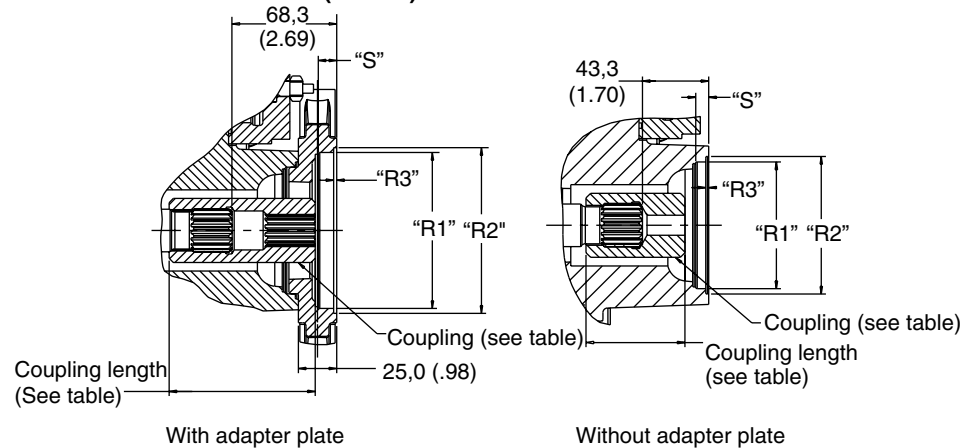

Coupling	Length	Code
SAE "A," 9T	64,5 (2.54)	A,G
SAE "A," 11T	65,3 (2.57)	B,H
SAE "B," 13T	95,3 (3.75)	C,J
SAE "B-B," 15T	95,3 (3.75)	D,K
SAE "C," 14T	95,3 (3.75)	E,L
SAE "C-C," 17T	91,8 (3.61)	F,M

## Model code Position 25

Description
A SAE "A," 9T, 16/32 DP, 30° pressure angle, involute spline
B SAE "A," 11T, 16/32 DP, 30° pressure angle, involute spline
C SAE "B," 13T, 16/32 DP, 30° pressure angle, involute spline
D SAE "B-B," 15T, 16/32 DP, 30° pressure angle, involute spline
E SAE "C," 14T, 12/24 DP, 30° pressure angle, involute spline
F SAE "C-C," 17T, 12/24 DP, 30° pressure angle, involute spline
G For ISO 80-A2HW pad with a 9T SAE spline
H For ISO 80-A2HW pad with a 11 T SAE spline
J For ISO 100-A2/B4HW pad with a 13T SAE spline
K For ISO 100-A2/B4HW pad with a 15T SAE spline
L For ISO 125-A2/B4HW pad with a 14T SAE spline
M For ISO 125-A2/B4HW pad with a 17T SAE spline

## "B" Adapter Flange

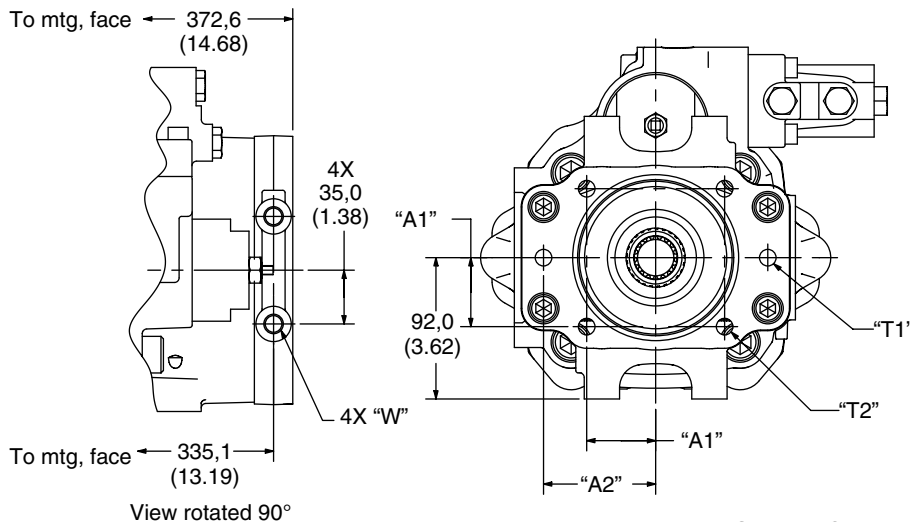

Right hand rotation with Load Sensing Control and ISO or SAE 2-1/4-bolt "B" adapter flange

Model Code	Position 25 Flange Bolt	Pilot Dia.	O-ring			Pilot Depth	2-bolt	4-bolt	Support Mounting Points "W"	4-bolt "A1"	2-bolt "A2"
			"R1"	"R2"	"R3"						
A,B G,H	SAE "A" SAE 2-bolt	Ø82,6 (3.25)	Ø89,65 (3.53)	2,00 (.08) 1,90 (.07)	9,0/8,0 (.35/.31)	375-16 UNC-2B thd.	N/A	N/A	N/A	53,2	
	ISO 80 ISO	Ø80,05 (3.15)	Ø89,75 (3.53)	2,70 (.11) 2,60 (.10)	9,0/8,0 (.35/.31)	M10 thd.	N/A	N/A	N/A	54,5 (2.15)	
C,D J,K	SAE "B" SAE 2-1/4-bolt	Ø101,65 (4.00)	Ø108,05 (4.25)	2,00 (.08) 1,90 (.07)	12,5/11,5 (.49/.45)	.50-13 UNC-2B thd.	.50-13 UNC-2B thd.	.50-13 UNC-2B thd. .98" deep(1.77)	44,9 (2.87)	73,0	
	ISO 100 ISO	Ø100,05 (3.94)	Ø108,75 (4.28)	2,70 (.11) 2,60 (.10)	12,5/11,5 (.49/.45)	M12 thd.	M10 thd.	M12 thd. 25,0 deep (1.74)	44,19 (1.74)	70,0 (2.76)	



# Thru-drive Models

PVM074/081

\*Right-hand only

## Dimensions in millimeters (inches)

### “C” Adapter Flange

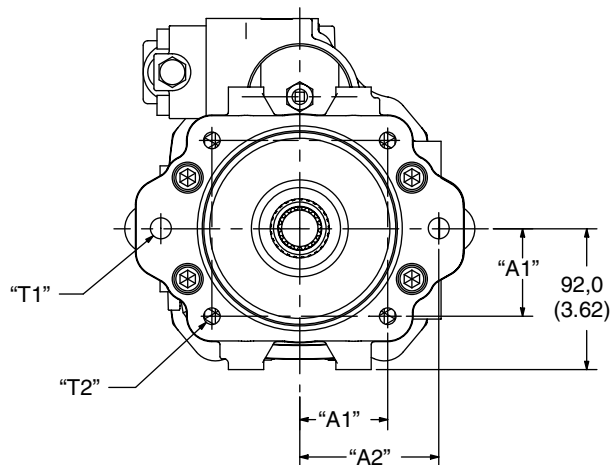
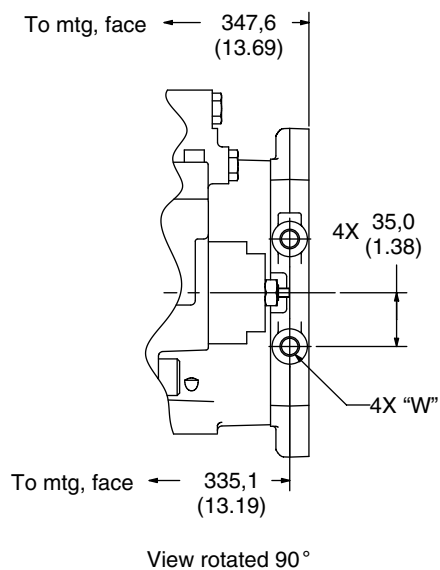

**Left hand rotation with Pressure Compensator and ISO or SAE 2-/4-bolt “C” Adapter Flange**

Model Code	Position 25 Flange	Bolt	Pilot Dia.	O-ring			Pilot Depth	2-bolt		4-bolt		Support Mounting Points		
				“R1”	“R2”	“R3”		“S”	“T1”	“T2”	“W”	“A1”	“A2”	
E,F L,M	SAE “C”	SAE	Ø127,05	Ø133,45	2,00 (.08)	15,5/14,5	.625-11	UNC-2B	thd.	.50-13	UNC-2B	.50-13 UNC-2B	57,25	90,5
	2-/4-bolt											thd. .98” deep	(2.25)	(3.56)
	ISO 125	ISO	Ø125,05	Ø133,75	2,70 (.11)	15,5/14,5	M16	thd.		M12	thd.	M12 thd. 25,0 deep	56,57	90,0
			(4.92)	(3.26)	2,60 (.10)	(.61/.57)							(2.23)	(3.54)

# Side-ported Models

PVM098/106

## Dimensions in millimeters (inches)

See pilot flange options on page 101.  
See shaft options starting on page 102.

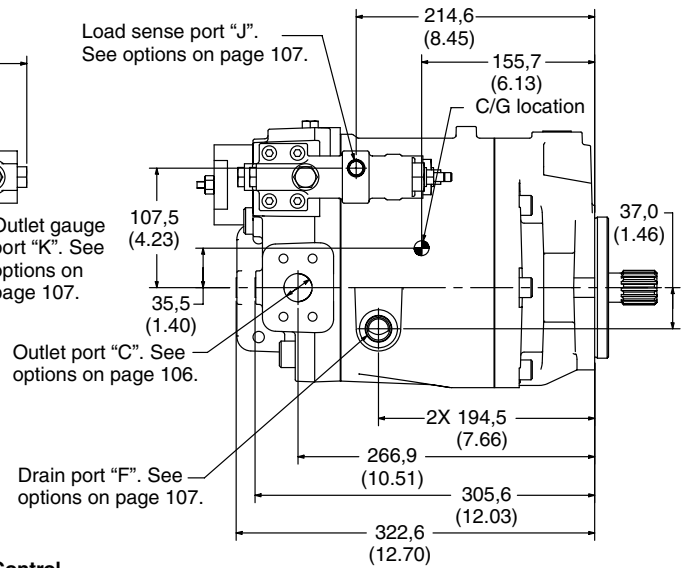
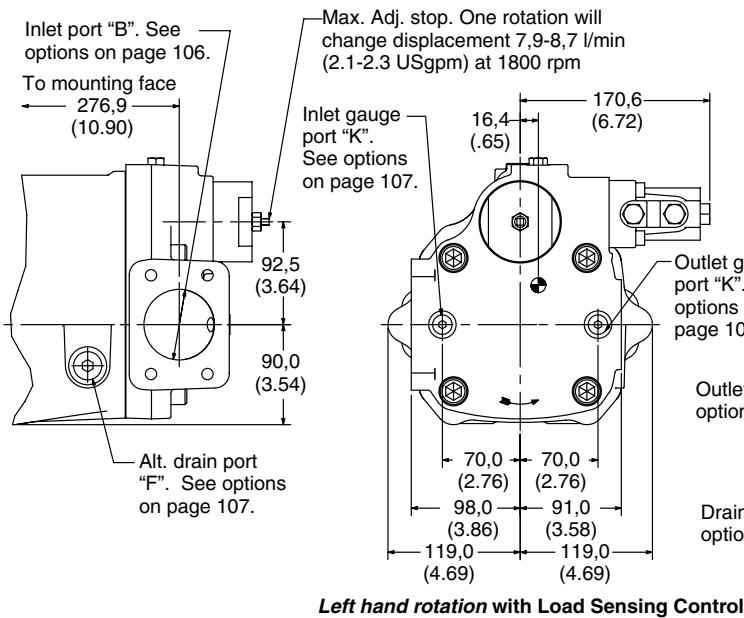
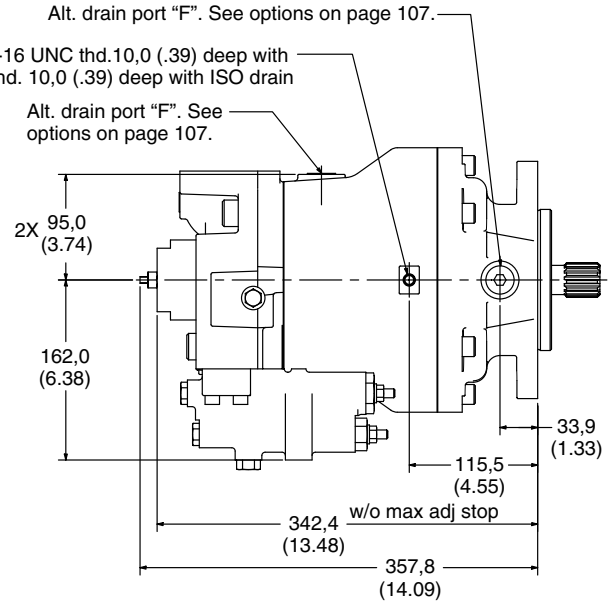
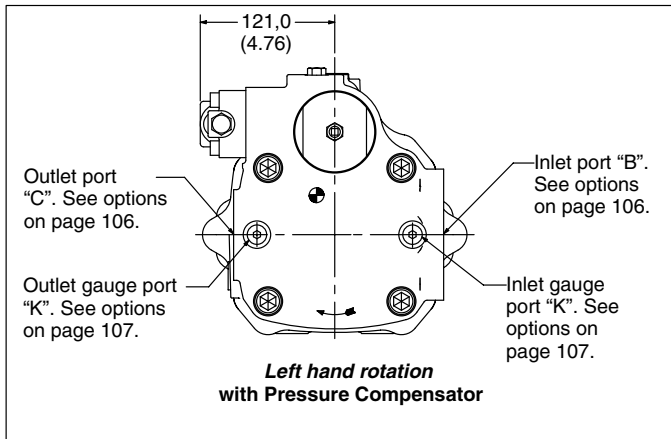

PVM098/106 is not available in left hand rotation with rear ports.

# Thru-drive Models

PVM098/106

## Dimensions in millimeters (inches)

See pilot flange options on page 101.  
See shaft options starting on page 102.

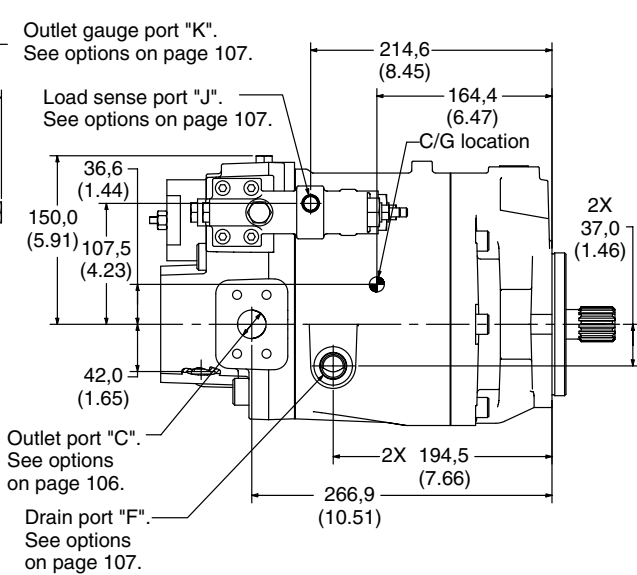
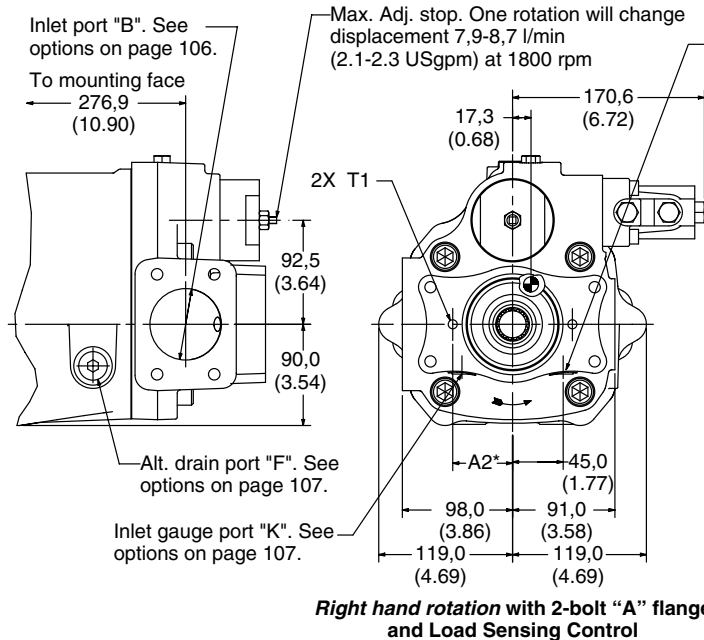
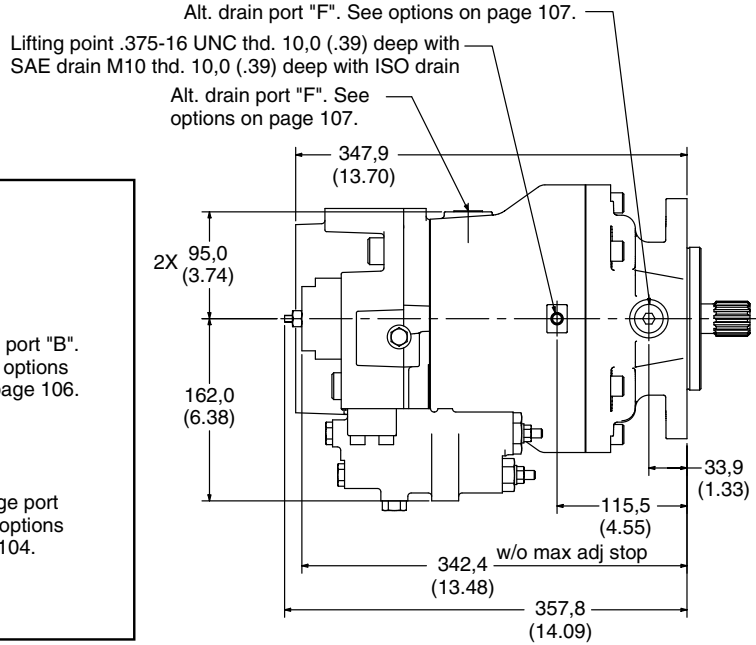
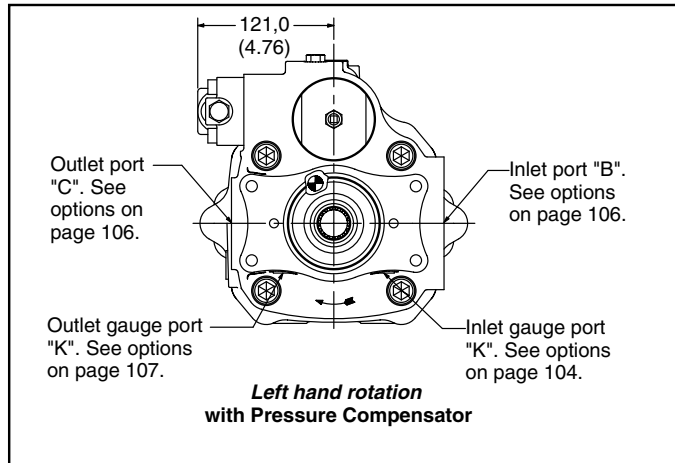

PVM098/106 is not available in left hand rotation with rear ports.

# Thru-drive Models

PVM098/106

## Dimensions in millimeters (inches)

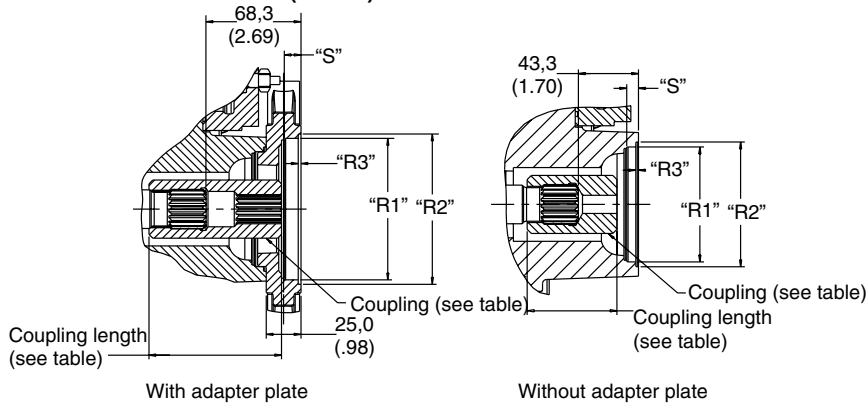

## "B" Adaptor Flange

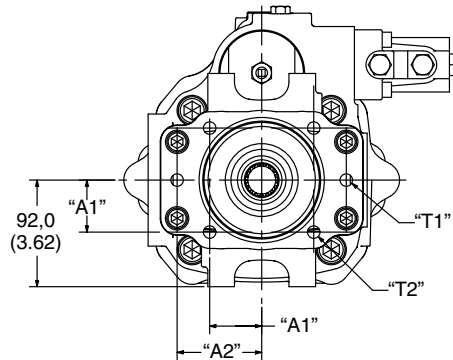
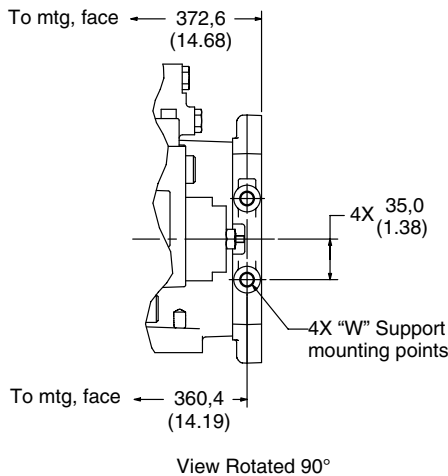

Right hand rotation with Load Sensing Control

Coupling	Length	Code
SAE "A," 9T	64,5 (2.54)	A,G
SAE "A," 11T	65,3 (2.57)	B,H
SAE "B," 13T	95,3 (3.75)	C,J
SAE "B-B," 15T	95,3 (3.75)	D,K
SAE "C," 14T	95,3 (3.75)	E,L
SAE "C-C," 17T	91,8 (3.61)	F,M

## Model Code Position 25

Description
A SAE "A," 9T, 16/32 DP, 30° pressure angle, involute spline
B SAE "A," 11T, 16/32 DP, 30° pressure angle, involute spline
C SAE "B," 13T, 16/32 DP, 30° pressure angle, involute spline
D SAE "B-B," 15T, 16/32 DP, 30° pressure angle, involute spline
E SAE "C," 14T, 12/24 DP, 30° pressure angle, involute spline
F SAE "C-C," 17T, 12/24 DP, 30° pressure angle, involute spline
G For ISO 80-A2HW pad with a 9T SAE spline
H For ISO 80-A2HW pad with a 11 T SAE spline
J For ISO 100-A2/B4HW pad with a 13T SAE spline
K For ISO 100-A2/B4HW pad with a 15T SAE spline
L For ISO 125-A2/B4HW pad with a 14T SAE spline
M For ISO 125-A2/B4HW pad with a 17T SAE spline

Model Code	Position 25 Flange Bolt	Pilot Dia.	O-ring			Pilot Depth	2-bolt	4-bolt	Support Mounting Points	4-bolt	2-bolt
			"R1"	"R2"	"R3"						
A,B	SAE "A" SAE	Ø82,6	Ø89,65	2,00 (.08)	9,0/8,0	375-16 UNC-2B	N/A	N/A	N/A	N/A	53,2
G,H	2-bolt ISO 80	Ø80,05 (3.15)	Ø89,75 (3.53)	1,90 (.07) (2,60 (.10))	(.35/.31) (9,0/8,0) (3.5/3.1)	thd. 0.59 deep	M10 thd. x 18,0 deep	N/A	N/A	N/A	54,5 (2.15)
C,D	SAE "B" SAE	Ø101,65 (4.00)	Ø108,05 (4.25)	2,00 (.08) (1,90 (.07))	12,5/11,5 (4.9/4.5)	.50-13 UNC-2B thd.	.50-13 UNC-2B thd.	.50-13 UNC-2B thd. .98" deep	44,9 (1.77)	73,0 (2.87)	
J,K	2-4-bolt ISO 100	Ø100,05 (3.94)	Ø108,75 (4.28)	2,70 (.11) (2,60 (.10))	12,5/11,5 (4.9/4.5)	M12 thd.	M10 thd.	M12 thd. 25,0 deep	44,19 (1.74)	70,0 (2.76)	

# Thru-drive Models

PVM098/106

## Dimensions in millimeters (inches)

### “C” Adapter Flange

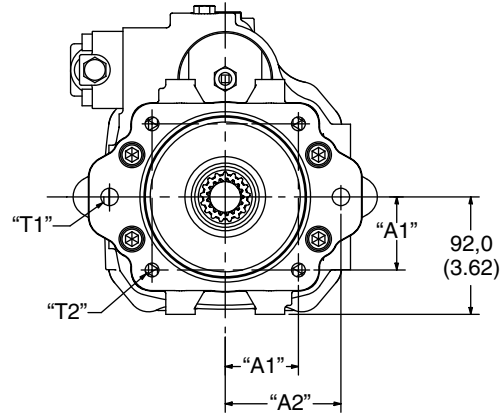
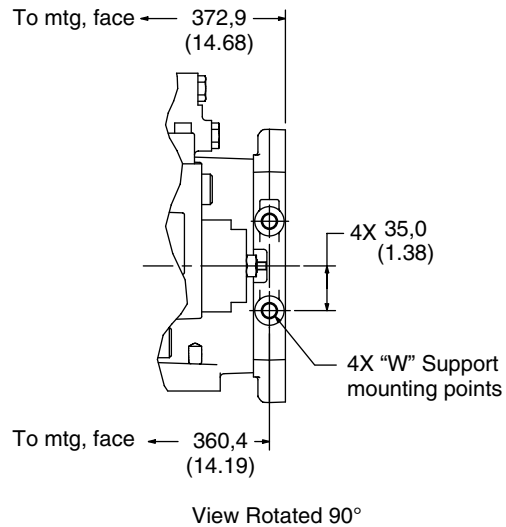

Left hand rotation with Pressure Compensator and ISO or SAE 2-/4-bolt “C” adapter flange

Model Code	Position 25 Flange	Bolt	Pilot Dia.	O-ring Dia.	O-ring Depth	Pilot Depth	Support Mounting Points				
			“R1”	“R2”	“R3”	“S”	2-bolt “T1”	4-bolt “T2”	“W”	“A1”	“A2”
E,F L,M	SAE “C” 2-/4-bolt	SAE	Ø127,05	Ø133,45	2,00 (.08)	15,5/14,5	.625-11 UNC-2B thd.	.50-13 UNC-2B thd.	.50-13 UNC-2B thd. .98” deep	57,25 (2.25)	90,5 (3.56)
			Ø125,05 (4.92)	Ø133,75 (3.26)	2,70 (.11) 2,60 (.10)	15,5/14,5 (.61/.57)	M16 thd.	M12 thd.	M12 thd. 25,0 deep	56,57 (2.23)	90,0 (3.54)

# End-ported Models

PVM131/141

## Dimensions in millimeters (inches)

See pilot flange options on page 101.

See shaft options starting on page 102.

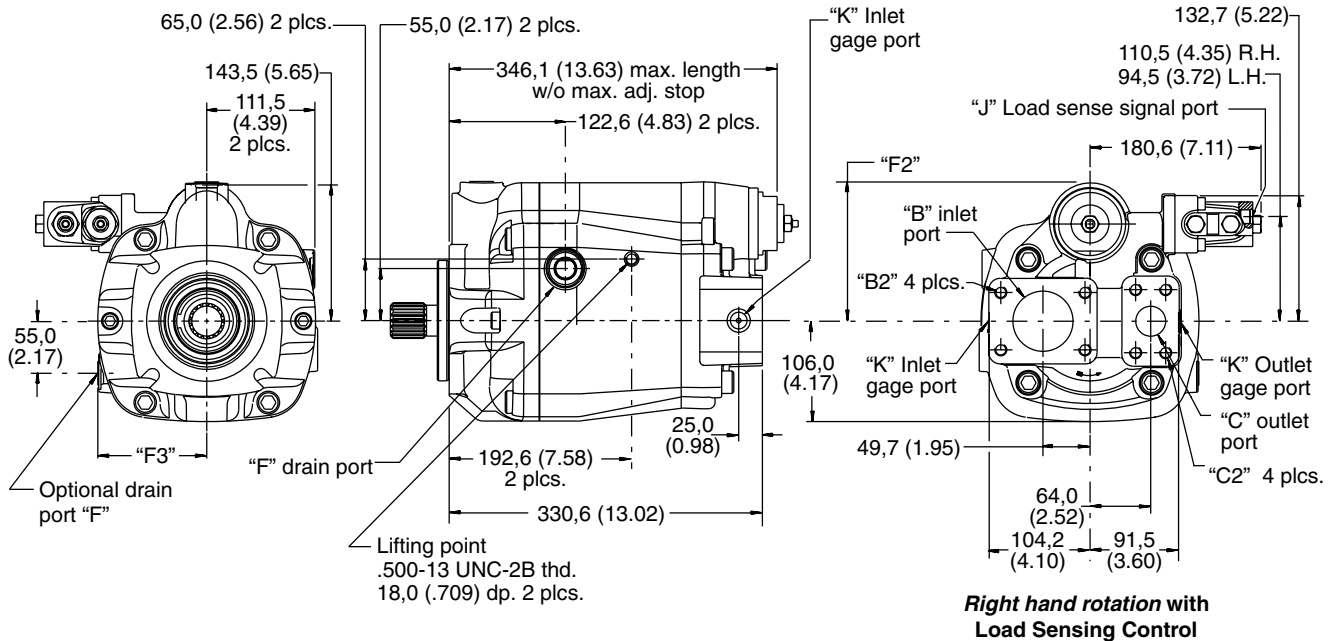
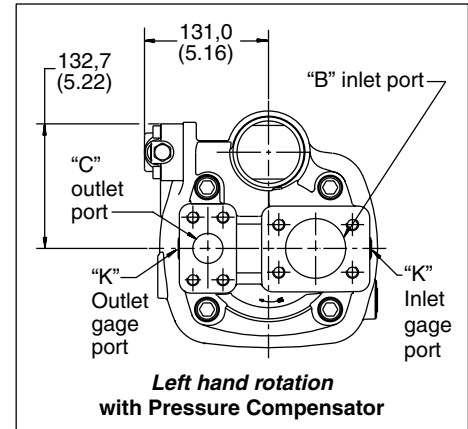
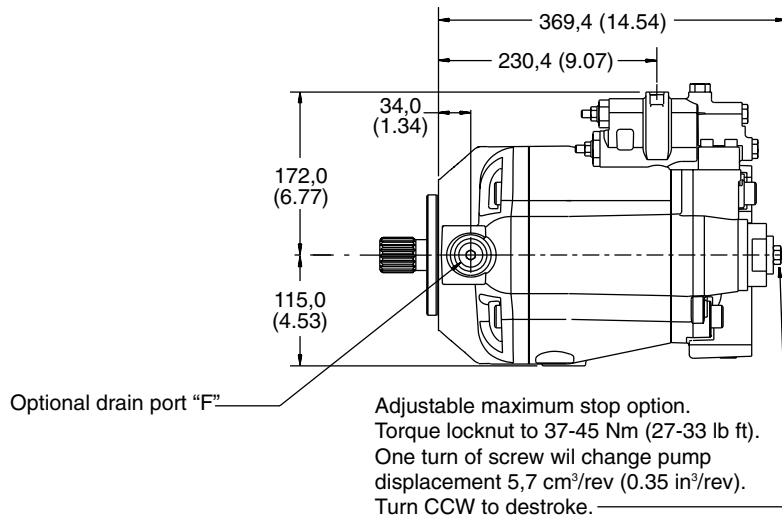

# Side-ported Models

PVM131/141

## Dimensions in millimeters (inches)

See pilot flange options on page 101.

See shaft options starting on page 102.

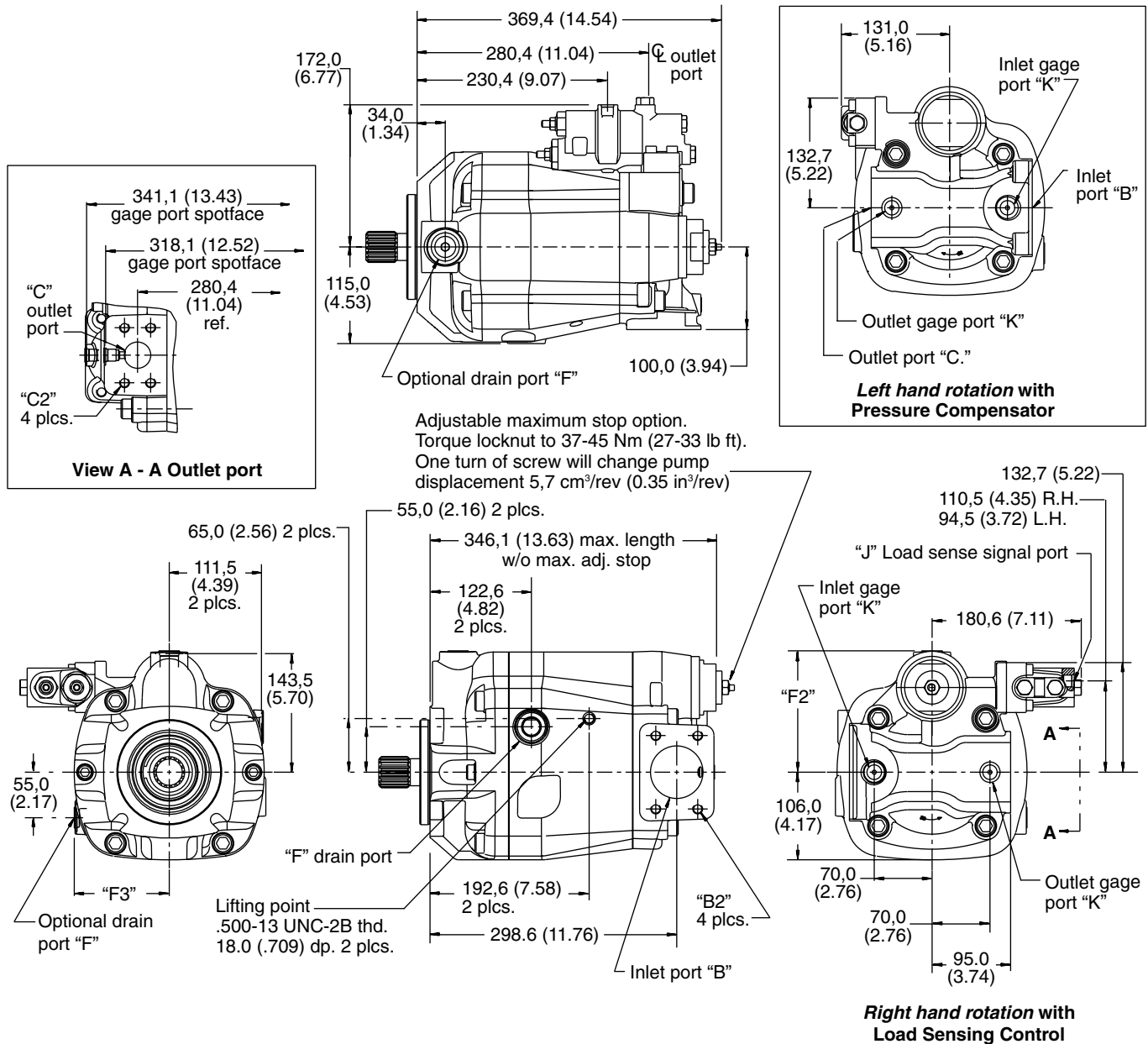

# Thru-drive Models

PVM131/141

## Dimensions in millimeters (inches)

See pilot flange options on page 101.

See shaft options starting on page 102.

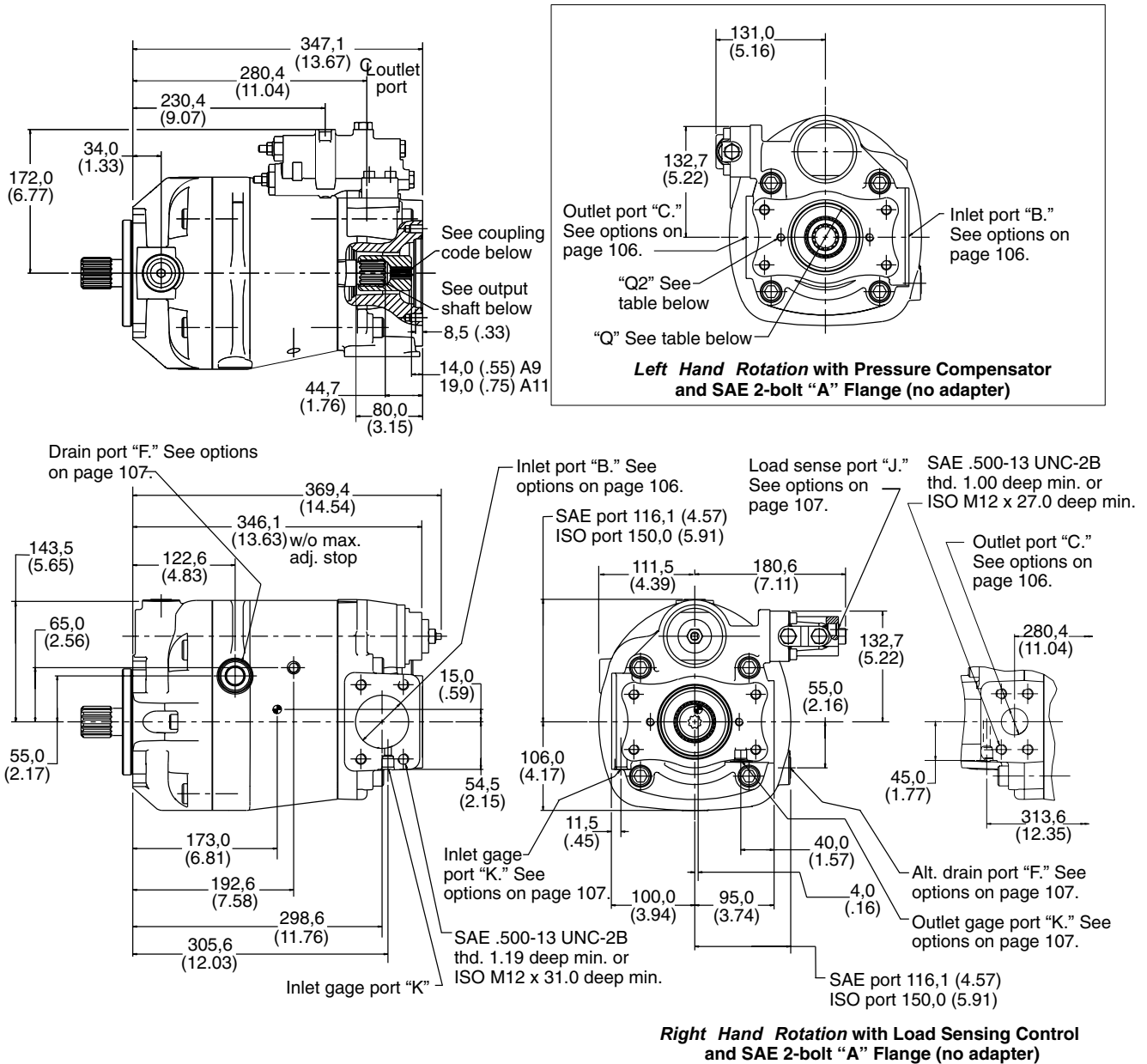

Model Code Position	"Q1" Thru-drive Flange	"Q2" 2-bolt Thread
A,B	SAE J744-82-2 Ø82.625/82.575 bore	.375-16 UNC-2B thd. 0.80 deep
G,H	ISO 3019/2-80A2 Ø80.075/80.25 bore	M10 thd. x 18,0 deep



# Thru-drive Models

PVM131/141

## Dimensions in millimeters (inches)

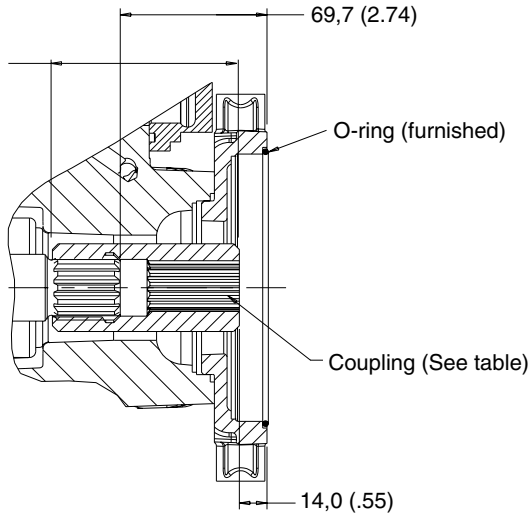

## Model Code Position 25

Model Code	Description
A	For SAE "A" pad with a 9T, 16/32 DP, 30° pressure angle, involute spline
B	For SAE "A" pad with a 11T, 16/32 DP, 30° pressure angle, involute spline
Output shaft	14T 12/24 DP external involute spline
C	SAE "B," 13T, 16/32 DP, 30° pressure angle, involute spline
D	SAE "B-B," 15T, 16/32 DP, 30° pressure angle, involute spline
E	SAE "C," 14T, 12/24 DP, 30° pressure angle, involute spline
F	SAE "C-C," 17T, 12/24 DP, 30° pressure angle, involute spline
G	For ISO 80-A2HW pad with a 9T SAE spline
H	For ISO 80-A2HW pad with a 11T SAE spline
J	For ISO 100-A2/B4HW pad with a 13T SAE spline
K	For ISO 100-A2/B4HW pad with a 15T SAE spline
L	For ISO 125-A2/B4HW pad with a 14T SAE spline
M	For ISO 125-A2/B4HW pad with a 17T SAE spline

## "B" Adapter Flange

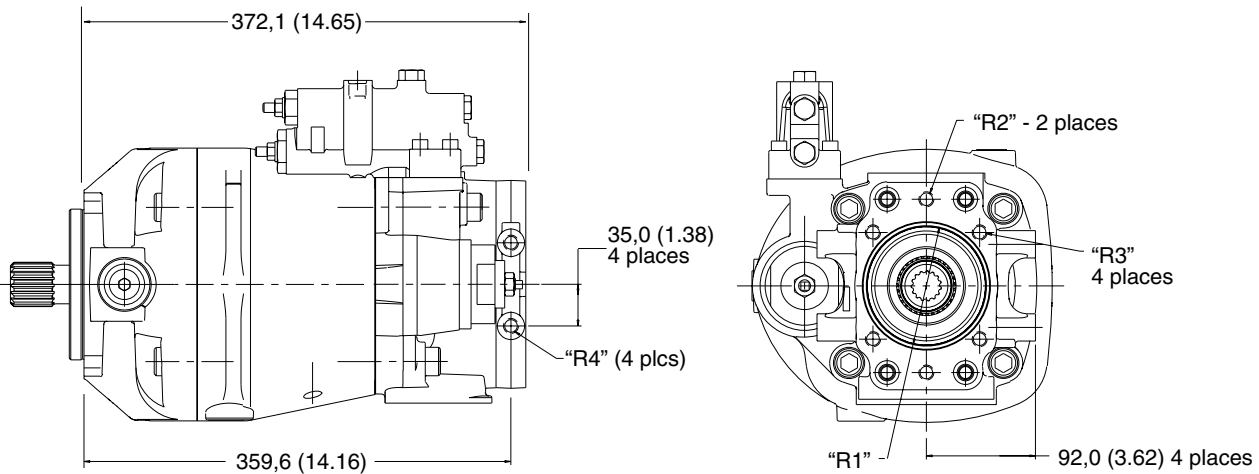

**Right Hand Rotation with SAE 2-1/4-Bolt "B" Flange and ISO 100 Adapter Flange**

Model Code	"R1" Thru-drive Flange	"R2" 2-bolt Thread	"R3" 4-bolt Thread	"R4" Support Mounting Points
C,D	SAE J744-101-2 & -4 Ø101,675/101.625 bore 12,50/11,50 deep	.500-13 UNC-2B 0,98 deep	.500-13 UNC-2B 0,98 deep	.500-13 UNC-2B 0,98 deep
J,K	ISO 3019/2-100A2 & B2 Ø100,075/100.025 bore 12,50/11,50 deep	M12 25,0 deep	M12 25,0 deep	M12 25,0 deep

# Thru-drive Models

PVM131/141

## Dimensions in millimeters (inches)

### “C” Adapter Flange

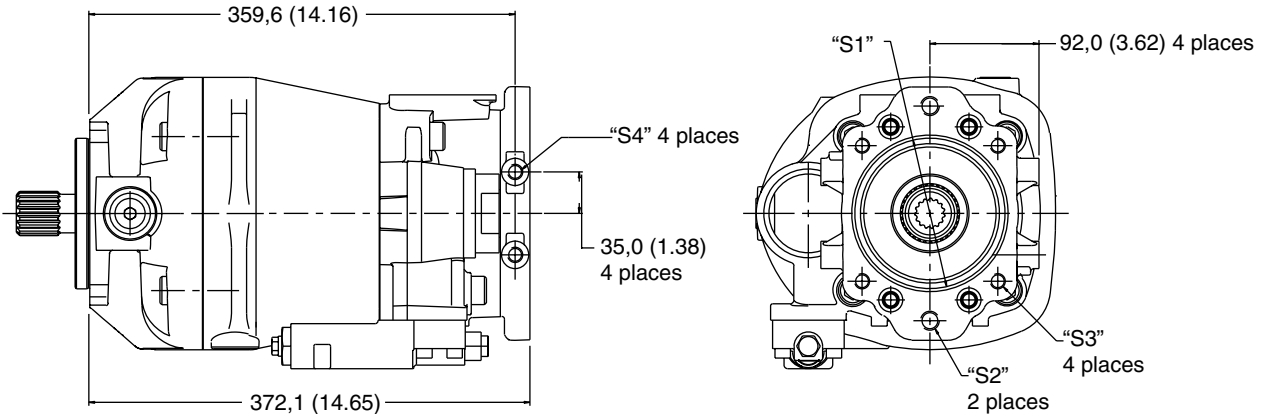

**Left Hand Rotation with SAE 2-1/4-bolt “C” and ISO 125 Adapter Flange**

### Model Code

Position 25	“S1” Thru-drive Flange	“S2” 2-bolt Thread	“S3” 4-bolt Thread	“R4” Support Mounting Points
E,F	SAE J744-127-2 & -4 Ø127,075/127.025 bore 15,50/14,50 deep	.625-11 UNC-2B 0.98 deep	.500-13 UNC-2B 0.98 deep	.500-13 UNC-2B 0.98 deep
L,M	ISO 3019/2-125A2 & B4 Ø125,075/125.025 bore 15,50/14,50 deep	M16 25,0 deep	M12 25,0 deep	M12 25,0 deep

Port	“B”*	“B2”	“C”*	“C2”	“F2”	“F3”
SAE	2.50 inch dia. SAE J518 Code 61, low pressure	.500-13 UNC-2B thd. 1.19 deep minimum	1.25 inch dia. SAE J518 Code 62, high pressure	.500-13 UNC-2B thd. 1.00 deep minimum	146,8 (5.78)	114,9 (4.52)
ISO	64mm diameter. ISO 6162 Type II, 315 bar	M12 thread 31,0 deep minimum	32mm diameter. ISO 6162, 400 bar	M12 thread 27,0 deep minimum	148,5 (5.85)	116,6 (4.59)

\*4-bolt flange port. See page 101 for load sensing, drain, and gage port threads.

# Mounting Flange Options

## Dimensions in millimeters (inches)

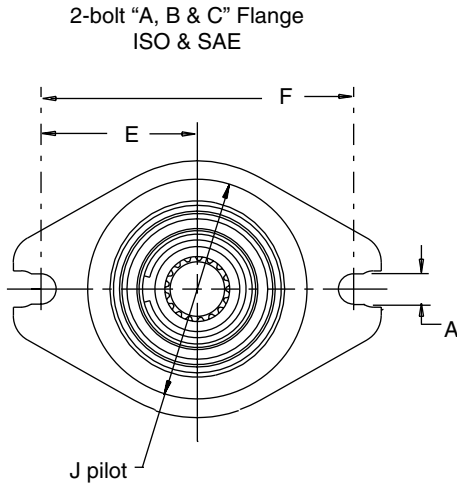

2-bolt "B" Flange  
4-bolt "C" or "D" Flange  
ISO & SAE

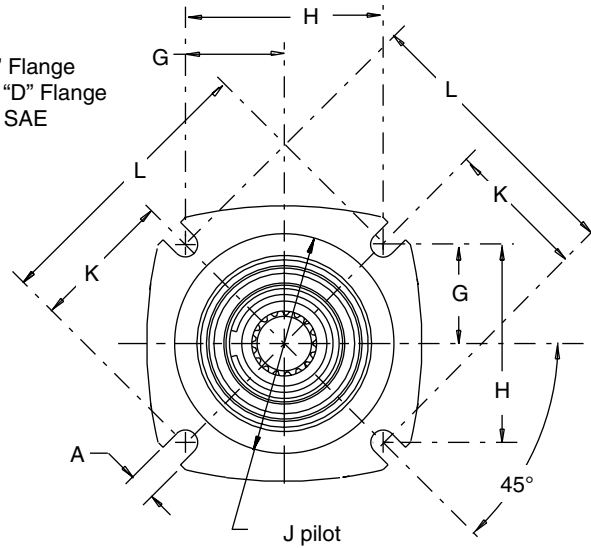

Series	2-bolt or 4-bolt Flange	Code	Flange Description	A	E	F	G	H	J	K	L
PVM018	2-bolt	A	SAE J744-82-2	Ø11,14	53,2	106,4	-	-	Ø82,53 +.02 -.03	-	-
PVM020	"A"			(4.38)	(2.09)	(4.19)	-	-	(Ø3.249) +.000 -.001	-	-
PVM018	2-bolt	B	ISO 3019/2-80A2HW	Ø11,14	54,5	109,0	-	-	Ø79,98 +.02 -.03	-	-
PVM020	"A"			(4.38)	(2.15)	(4.29)	-	-	(Ø3.15) +.000 -.001	-	-
PVM018 PVM020 PVM045 PVM050 PVM057 PVM063	2-bolt "B"	C	SAE J744-101-2	14,36	73,0	146,0	-	-	Ø101,58+.02 -.03	-	-
				(.565)	(2.87)	(5.75)	-	-	(Ø3.999) ±.001	-	-
PVM018 PVM020 PVM045 PVM050 PVM057 PVM063	2-bolt "B" (special)	D	ISO 3019/2-100A2HW	14,14	70,0	140,0	-	-	Ø100,00/99,95 (Ø3.937/3.935)	-	-
				(.557)	(2.76)	(5.51)	-	-		-	-
PVM057 PVM063	2-bolt "C"	E	SAE J744-127-2 ("C")	17,4	90,5	181,0	-	-	Ø127,00/126,95 (Ø5.000/4.998)	-	-
PVM074 PVM081		F	ISO 3019/2-125A2HW	18,0	90,0	180,0	-	-	Ø125,00/124,95 (Ø4.921/4.919)	-	-
				(.709)	(3.543)	(7.09)	-	-		-	-
PVM098 PVM106 PVM131 PVM141	4-bolt "C"	G	SAE J744-127-4 ("C")	14,2	-	-	57,25	114,50	Ø127,00/126,95 (Ø5.000/4.998)	-	-
				(.559)	-	-	(2.254)	(4.508)		-	-
		H	ISO 3019/2-125B4HW	14,0	-	-	-	-	Ø125,00/124,95 (Ø4.921/4.919)	80,0 (3.150)	160,0 (6.299)
				(.551)	-	-	-	-			
PVM131 PVM141	4-bolt "D"	J	SAE J744-152-4 ("D")	20,6	-	-	80,82	161,64	Ø152,40/152,35 (Ø6.000/5.998)	-	-
				(.812)	-	-	(3.182)	(6.364)		-	-
		K	ISO 3019/2-160B4HW	18,0	-	-	-	-	Ø160,00/159,95 (Ø6.299/6.297)	100,0 (3.937)	200,0 (7.874)
				(.709)	-	-	-	-			

\*Flanges for PVM020 and PVM050 are shown on pages 73 and 80, respectively.

# Shaft Options

Dimensions in millimeters (inches)

## SAE Splined Shaft

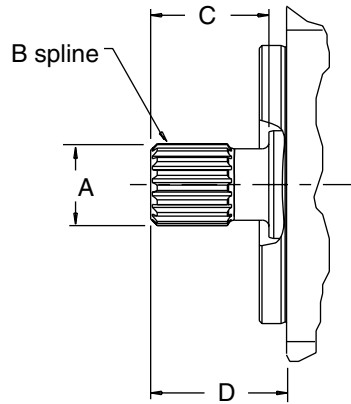

Model Series	SAE Spline Shaft Designation	Shaft Code	A max.	B	C	D	Max. Input Torque Nm (lb. in.)
PVM018/020	SAE J744-16-4 SAE "A" (9T)	03	15,88 (.625)	9T 16/32 DP	37,0 (1.46)	32,0 (1.26)	58 (517)
	SAE J744-19-4 SAE "A" (11T)	04	19,05 (.750)	11T 16/32 DP	30,0 (1.18)	38,0 (1.50)	123 (1100)
	SAE J744-22-4 SAE "B" (13T)	07	21,81 (.859)	13T 16/32 DP	33,0 (1.31)	41,0 (1.61)	208 (1850)
	SAE J744-25-4 SAE "B-B" (15T)	08	24,98 (.983)	15T 16/32 DP	38,0 (1.50)	46,0 (1.81)	337 (2987)
PVM045/050	SAE J744-22-4 SAE "B" (13T)	07	21,81 (.859)	13T 16/32 DP	33,0 (1.31)	41,0 (1.61)	208 (1850)
	SAE J744-25-4 SAE "B-B" (15T)	08	24,98 (.983)	15T 16/32 DP	38,0 (1.50)	46,0 (1.81)	337 (2987)
PVM057/063	SAE J744-22-4 SAE "B" (13T)	07	21,81 (.859)	13T 16/32 DP	33,0 (1.31)	41,0 (1.61)	208 (1850)
	SAE J744-25-4 SAE "B-B" (15T)	08	24,98 (.983)	15T 16/32 DP	38,0 (1.50)	46,0 (1.81)	337 (2987)
	SAE J744-32-4 SAE "C" (14T)	11	31,22 (1.23)	14T 12/24 DP	48,0 (1.89)	56,0 (2.20)	640 (5660)
PVM074/081 PVM098/106	SAE J744-32-4 SAE "C" (14T)	11	31,22 (1.23)	14T 12/24 DP	48,0 (1.89)	56,0 (2.20)	640 (5660)
	SAE J744-38-4 SAE "C-C" (17T)	12	37,57 (1.479)	17T 12/24 DP	54,0 (2.13)	62,0 (2.44)	1215 (10,750)
PVM131/141	SAE J744-32-4 SAE "C" (14T)	11	31,22 (1.23)	14T 12/24 DP	48,0 (1.89)	56,0 (2.20)	640 (5660)
	SAE J744-38-4 SAE "C-C" (17T)	12	37,57 (1.479)	17T 12/24 DP	54,0 (2.13)	62,0 (2.44)	1215 (10,750)
	SAE J744-44-4 SAE "D" (13T)	14	43,71 (1.721)	13T 8/16 DP	67,0 (2.63)	75,0 (2.95)	1215 (10,750)

# Shaft Options

Dimensions in millimeters (inches)

## SAE Keyed Shaft

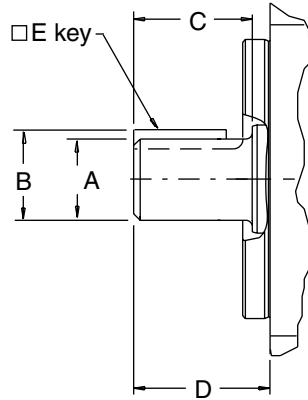

Model Series	SAE Keyed Shaft Designation	Shaft Code	A	B	C	D	E	Max. Input Torque Nm (lb. in.)
PVM018/020	SAE J744-16-1 SAE "A"	01	15,88 (.625)	17,73 (.698)	24,0 (.94)	32,0 (1.26)	4,0 (.157)	58 (517)
	SAE J744-19-1 SAE "19-1"	02	19,05 (.750)	21,23 (.836)	24,0 (.94)	32,0 (1.26)	4,81 (.189)	104 (918)
	SAE J744-22-1 SAE "B"	05	22,22 (.875)	25,12 (.989)	33,0 (1.31)	41,0 (1.61)	6,35 (.250)	135 (1200)
	SAE J744-25-1 SAE "B-B"	06	25,37 (.999)	28,22 (1.111)	38,0 (1.50)	46,0 (1.81)	6,35 (.250)	215 (1900)
PVM045/050	SAE J744-22-1 SAE "B"	05	22,22 (.875)	25,12 (.989)	33,0 (1.31)	41,0 (1.61)	6,35 (.250)	135 (1200)
	SAE J744-25-1 SAE "B-B"	06	25,37 (.999)	28,22 (1.111)	38,0 (1.50)	46,0 (1.81)	6,35 (.250)	215 (1900)
PVM057/063	SAE J744-25-1 SAE "B-B"	06	25,37 (.999)	28,22 (1.111)	38,0 (1.50)	46,0 (1.81)	6,35 (.250)	215 (1900)
	SAE J744-32-1 SAE "C"	09	31,75 (1.25)	35,32 (1.390)	48,0 (1.89)	56,0 (2.20)	7,93 (.312)	450 (3980)
PVM074/081	SAE J744-32-1 SAE "C"	09	31,75 (1.25)	35,32 (1.390)	48,0 (1.89)	56,0 (2.20)	7,93 (.312)	450 (3980)
PVM098/106	SAE J744-38-1 SAE "C-C"	10	38,10 (1.50)	42,39 (1.67)	54,0 (2.13)	62,0 (2.44)	9,52 (.375)	765 (6770)
PVM131/141	SAE J744-32-1 SAE "C"	09	31,75 (1.25)	35,32 (1.390)	48,0 (1.89)	56,0 (2.20)	7,93 (.312)	450 (3980)
	SAE J744-38-1 SAE "C-C"	10	38,10 (1.50)	42,39 (1.67)	54,0 (2.13)	62,0 (2.44)	9,52 (.375)	765 (6770)
	SAE J744-44-1 SAE "D"	13	44,45 (1.75)	49,46 (1.95)	67,0 (2.63)	75,0 (2.95)	11,11 (.438)	1200 (10,620)

# Shaft Options

Dimensions in millimeters (inches)

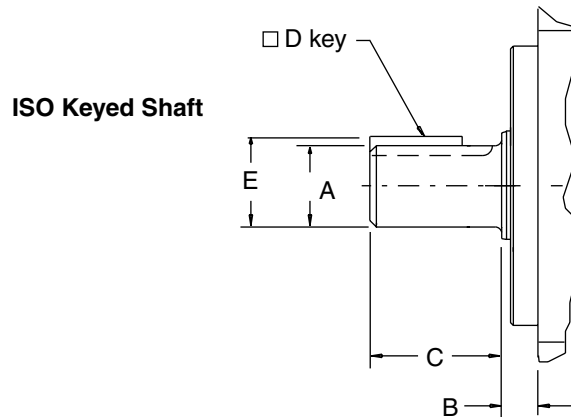

Model Series	ISO Keyed Shaft Designation	Shaft Code	A	B	C	D	E	Max. Input Torque Nm (lb. in.)
PVM018/020	ISO 3019/2 E20N	15	19,9 (.786)	8,5 (.335)	36 (1.42)	6 (.236)	22,5 (.886)	113 (1000)
	ISO 3019/2 E25N	16	25 (.984)	8,5 (.335)	42 (1.65)	8 (.315)	28,0 (1.102)	215 (1900)
	Short Spigot							
	ISO 3019/2 E25N	17	25 (.984)	10 (.393)	42 (1.65)	8 (.315)	28,0 (1.102)	215 (1900)
PVM045/050	ISO 3019/2 E25N	17	25 (.984)	10 (.393)	42 (1.65)	8 (.315)	28,0 (1.102)	215 (1900)
PVM057/063	ISO 3019/2 E25N	17	25 (.984)	10 (.393)	42 (1.65)	8 (.315)	28,0 (1.102)	215 (1900)
	ISO 3019/2 E32N	18	32 (1.26)	10 (.393)	58 (2.28)	10 (.394)	35,0 (1.378)	450 (3980)
PVM074/081	ISO 3019/2 E32N	18	32 (1.26)	10,5 (.413)	58 (2.28)	10 (.394)	35,0 (1.378)	450 (3980)
PVM098/106	ISO 3019/2 E40N	19	40 (1.57)	10,5 (.413)	82 (3.23)	12 (.472)	43,0 (1.693)	870 (7700)
PVM131/141	ISO 3019/2 E32N	18	32 (1.26)	10 (.393)	58 (2.28)	10 (.394)	35,0 (1.378)	450 (3980)
	ISO 3019/2 E40N	19	40 (1.57)	10 (.393)	82 (3.23)	12 (.472)	43,0 (1.693)	870 (7700)

<sup>1)</sup>ISO 80mm pilot only – B

<sup>2)</sup>ISO 80mm pilot only – D

\*Torque of non-thru-drive PVM pump, or combined torque of PVM thru-drive pump and thru-driven pump.

**NOTE:** In those cases where geometric tolerances of mounting are critical, or where specific tolerance ranges are required and not specified, consult Eaton Engineering for specific limits.

# Input Shaft Selection Data

## SAE Splined Shafts

Model Series	Shaft Designation	Shaft Code	Max. Input Torque† Nm (lb. in.)	Max. Thru-drive Output Torque‡ Nm (lb. in.)
PVM018/020	SAE J744-16-4 (SAE "A," 9T)	03	58 (513)	Exceeds maximum input torque
	SAE J744-19-4 (SAE "A," 11T)	04	123 (1100)	Exceeds maximum input torque
	SAE J744-22-4 (SAE "B," 13T)	07	208 (1850)	123 (1100)
	SAE J744-25-4 (SAE "B-B," 15T)	08	337 (2987)	123 (1100)
PVM045/050	SAE J744-22-4 (SAE "B," 13T)	07	208 (1850)	208 (1850)*
	SAE J744-25-4 (SAE "B-B," 15T)	08	337 (2987)	337 (2987)
PVM057/063	SAE J744-22-4 (SAE "B," 13T)	07	208 (1850)	208 (1850)*
	SAE J744-25-4 (SAE "B-B," 15T)	08	337 (2987)	337 (2987)
	SAE J744-32-4 (SAE "C," 14T)	11	640 (5660)	337 (2987)
PVM074/081	SAE J744-32-4 (SAE "C," 14T)	11	640 (5660)	515 (4560)
PVM098/106	SAE J744-38-4 (SAE "C-C," 17T)	12	1215 (10,750)	515 (4560)
	SAE J744-32-4 (SAE "C," 14T)	11	640 (5660)	640 (5660)
PVM131/141	SAE J744-38-4 (SAE "C-C," 17T)	12	1215 (10,750)	640 (5660)
	SAE J744-44-4 (SAE "D," 13T)	14	1215 (10,750)	640 (5660)

## SAE Keyed Shafts

Model Series	Shaft Designation	Shaft Code	Max. Input Torque† Nm (lb. in.)	Max. Thru-drive Output Torque‡ Nm (lb. in.)
PVM018/020	SAE J744-16-1 (SAE "A")	01	58 (513)	Exceeds maximum input torque
	SAE J744-19-1 (SAE "19-1")	02	104 (920)	Exceeds maximum input torque
	SAE J744-22-1 (SAE "B")	05	135 (1200)	123 (1100)
	SAE J744-25-1 (SAE "B-B")	06	215 (1900)	123 (1100)
PVM045/050	SAE J744-22-1 (SAE "B")	05	135 (1200)	135 (1200)*
	SAE J744-25-1 (SAE "B-B")	06	215 (1900)	215 (1900)*
PVM057/063	SAE J744-25-1 (SAE "B-B")	06	215 (1900)	215 (1900)*
	SAE J744-32-1 (SAE "C")	09	450 (3980)	337 (2987)
PVM074/081	SAE J744-32-1 (SAE "C")	09	450 (3980)	450 (3980)*
PVM098/106	SAE J744-38-1 (SAE "C-C")	10	765 (6770)	515 (4560)
	SAE J744-32-1 (SAE "C")	09	450 (3980)	450 (3980)*
PVM131/141	SAE J744-38-1 (SAE "C-C")	10	765 (6770)	640 (5660)
	SAE J744-44-1 (SAE "D")	13	1200 (10,620)	640 (5660)

## ISO Keyed Shafts

Model Series	Shaft Designation	Shaft Code	Max. Input Torque† Nm (lb. in.)	Max. Thru-drive Output Torque‡ Nm (lb. in.)
PVM018/020	ISO 3019/2 E20N (B mount only)	15	113 (1000)	Exceeds maximum input torque
	ISO 3019/2 E25N (B mount only)	16	215 (1900)	Exceeds maximum input torque
	ISO 3019/2 E25N (D mount only)	17	215 (1900)	123 (1100)
PVM045/050	ISO 3019/2 E25N	17	215 (1900)	215 (1900)*
PVM057/063	ISO 3019/2 E25N	17	215 (1900)	215 (1900)*
	ISO 3019/2 E32N	18	450 (3980)	337 (2987)
PVM074/081	ISO 3019/2 E32N	18	450 (3980)	450 (3980)*
PVM098/106	ISO 3019/2 E40N	19	870 (7700)	515 (4560)
PVM131/141	ISO 3019/2 E32N	18	450 (3980)	450 (3980)*
	ISO 3019/2 E40N	19	870 (7700)	640 (5660)

†Maximum total torque of the thru-drive pump and the thru-driven pump(s).

‡Maximum torque that can be applied to the thru-driven pump(s).

\*This value is limited by the maximum input torque.

# Port Options

## Inlet and Outlet Ports

Model Series	Inlet/Outlet Port Option (per model code, page 5)	Port Code	Inlet Port "B"	Outlet Port "C"
PVM018/020	Inch Flange	02	SAE J518 Code 61, standard pressure. 1.25 inch diameter, .4375-14 x 1.12 bolt holes	SAE J518 Code 61, standard pressure. 0.75 inches diameter, .375-16 x .88 bolt holes
	Metric Flange	04	ISO 6162 Type II, 315 bar. 31,75mm diameter, M10 x 28 bolt holes	ISO 6162 Type II, 315 bar. 19,05mm diameter, M10 x 22 bolt holes
	Inch Tube	01	SAE J514 O-ring -20, for 1-1/4 inch O.D. tube	SAE J514 O-ring -12, for 3/4 inch O.D. tube
	Metric Tube	03	ISO 6149-1, M48 thread	ISO 6149-1, M27 thread
	British Parallel Pipe	05	ISO 228-1:1994 (E), G 1-1/4 thread	ISO 228-1:1994 (E), G 3/4 thread
PVM045/050	Inch Flange	02	SAE J518 Code 61, standard pressure. 2.00 inch diameter, .500-13 x 1.06 bolt holes	SAE J518 Code 61, standard pressure. 1.00 inch diameter, .375-16 x .87 bolt holes
	Metric Flange	04	ISO 6162 Type II, 315 bar. 51mm diameter, M12 x 27 bolt holes	ISO 6162 Type II, 315 bar. 25mm diameter, M10 x 22 bolt holes
	Inch Tube	01	SAE J514 O-ring -24, for 1-1/2 inch O.D. tube	SAE J514 O-ring -16, for 1 inch O.D. tube
	Metric Tube	03	ISO 6149-1, M48 thread	ISO 6149-1, M33 thread
	British Parallel Pipe	05	ISO 228-1:1994 (E), G 1-1/2 thread	ISO 228-1:1994 (E), G1 thread
PVM057/063	Inch Flange	02	SAE J518 Code 61, standard pressure. 2.00 inch diameter, .500-13 x 1.06 bolt holes	SAE J518 Code 61, standard pressure. 1.00 inch diameter, .375-16 x .88 bolt holes
	Metric Flange	04	ISO 6162 Type II, 350 bar. 51mm diameter, M12 x 29 bolt holes	ISO 6162 Type, 350 bar. 25mm diameter, M10 x 23 bolt holes
	Inch Tube (End ported models only)	01	SAE J514 O-ring -24, for 1-1/2 inch O.D. tube	SAE J514 O-ring -16 for 1 inch O.D. tube
	Metric Tube (End ported models only)	03	ISO 6149-1, M48 thread	ISO 6149-1, M33 thread
PVM074/081	Inch Flange	02	SAE J518 Code 61, standard pressure. 2.00 inch diameter, .500-13 x 1.19 bolt holes	SAE J518 Code 61, standard pressure. 1.00 inch diameter, .375-16 x .88 bolt holes
	Metric Flange	04	ISO 6162 Type II, 315 bar. 51mm diameter, M12 x 20 bolt holes	ISO 6162 Type, 400 bar. 25mm diameter, M10 x 17 bolt holes
PVM098/106	Inch Flange	02	SAE J518 Code 61, standard pressure. 2.50 inch diameter, .500-13 x 1.19 bolt holes	SAE J518 Code 61, standard pressure. 1.00 inch diameter, .375-16 x .88 bolt holes
	Metric Flange	04	ISO 6162 Type I, 350 bar. 64mm diameter, M12 x 31 bolt holes	ISO 6162 Type I, 350 bar. 25mm diameter, M10 x 23 bolt holes
PVM131/141	Inch Flange	02	SAE J518 Code 61, standard pressure. 2.50 inch diameter, .500-13 x 1.19 bolt holes	SAE J518 Code 62, high pressure. 1.25 inch diameter, .500-13 x 1.00 bolt holes
	Metric Flange	04	ISO 6162 Type II, 315 bar. 64mm diameter, M12 x 31 bolt holes	ISO 6162 Type, 400 bar. 32mm diameter, M12 x 27 bolt holes



# Port Options

## Drain, Load Sensing, and Gauge Ports

Model Series	Inlet/Outlet Port Option (per model code, page 5)	Port Code	Drain Port "F"	Load Sensing Port "J"	Gauge Port "K"
PVM018/020	Inch Flange or Tube	01, 03	SAE J514 O-ring, .50" O.D. tube. .750-16 UNF 2B thread	SAE J514 O-ring, .25" O.D. tube. .4375-20 UNF 2B thread	SAE J514 O-ring, .25" tube. .4375-20 UNF 2B thread
	Metric Flange or Tube	03, 04	ISO 6149-1 O-ring M18 x 1,5 thread	ISO 6149-1 O-ring M12 x 1,5 thread	ISO 6149-1 O-ring M12 x 1,5 thread
	British Parallel Pipe	05	ISO 228-1:1994 (E) G 1/2 thread	ISO 228-1:1994 (E) G 1/4 thread	ISO 228-1:1994 (E) G 1/4 thread
PVM045/050	Inch Flange or Tube	01, 03	SAE J514 O-ring, .625" O.D. tube. .875-14 UNF 2B thread	SAE J514 O-ring, .250" O.D. tube. .4375-20 UNF 2B thread	SAE J514 O-ring, .375" O.D. tube. .5625-18 UNF 2B thread
	Metric Flange or Tube	03, 04	ISO 6149-1 O-ring M22 x 1,5 thread	ISO 6149-1 O-ring M12 x 1,5 thread	ISO 6149-1 O-ring M14 x 1,5 thread
	British Parallel Pipe	05	ISO 228-1:1994 (E) G 1/2 thread	ISO 228-1:1994 (E) G 1/4 thread	ISO 228-1:1994 (E) G 1/4 thread
PVM057/063	Inch Flange or Tube	01, 02	SAE J514 O-ring, .625" O.D. tube. .875-14 UNF 2B thread	SAE J514 O-ring, .375" O.D. tube. .5625-18 UNF 2B thread	SAE J514 O-ring, .375" O.D. tube. .5625-18 UNF 2B thread
	Metric Flange or Tube	03, 04	ISO 6149-1 O-ring M22 x 1,5 thread	ISO 6149-1 O-ring M14 x 1,5 thread	ISO 6149-1 O-ring M14 x 1,5 thread
PVM074/83 PVM098/106	Inch Flange	02	SAE J514 O-ring, .625" O.D. tube. .875-14 UNF 2B thread	SAE J514 O-ring, .375" O.D. tube. .562-18 UNF 2B thread	SAE J514 O-ring, .375" O.D. tube. .5625-18 UNF 2B thread
	Metric Flange	04	ISO 6149-1 O-ring M22 x 1,5 thread	ISO 6149-1 O-ring M14 x 1,5 thread	ISO 6149-1 O-ring M14 x 1,5 thread
PVM131/141	Inch Flange	02	SAE J514 O-ring, .625" O.D. tube. .875-14 UNF 2B thread	SAE J514 O-ring, .375" O.D. tube. .562-18 UNF 2B thread	SAE J514 O-ring, .375" O.D. tube. .5625-18 UNF 2B thread
	Metric Flange	04	ISO 6149-1 O-ring M22 x 1,5 thread	ISO 6149-1 O-ring M14 x 1,5 thread	ISO 6149-1 O-ring M14 x 1,5 thread

# Operating Requirements

## Inlet Pressure, Case Pressure, and Operating Temperature Requirements

Inlet Pressure			Case Pressure			Operating Temperature	
Rated Absolute bar (psi)	Minimum bar, absolute (in. Hg)	Maximum Gauge bar (psi)	Maximum Continuous bar (psi)	Maximum Intermittent bar (psi)	Peak bar (psi)	Rated °C (°F)	Maximum Intermittent °C (°F)
1,0 (14.5)	0,85 (5)	3,5 (50)	0,5 (7)	2 (30)	3,5 (50)	82 (180)	104 (220)

## Hydraulic Fluids

Fluid	Recommended Operating Viscosity Range cSt (SUS)	Maximum Viscosity at Startup cSt (SUS)	Minimum Viscosity @ Max. Intermittent Temperature of 104°C (220°F) cSt (SUS)
Use antiwear hydraulic oil, or automotive type crankcase oil (designations SC, SD, SE, or SF) per SAE J183 FEB80	16 to 40 (83 to 187)	1000 (4550)	10 (90)

For more information, see Eaton publication 579. For operation on other alternative or environmentally friendly fluids, please contact your Eaton Representative.

## Fluid Cleanliness

The M Series pumps are rated in anti-wear petroleum fluids with a contamination level of 20/18/13 (Eaton) or ISO 18/13. Operation in fluids with levels more contaminated than this is not recommended. Fluids other than petroleum, severe service cycles, or temperature extremes are cause for adjustment of these codes. Please contact your Eaton Representative for specific duty cycle recommendation.

Eaton M Series pumps, as with any variable displacement piston pumps, will operate with apparent satisfaction in fluids

up to the rating specified here. Experience has shown, however, that pump and hydraulic system life is not optimized with high fluid contamination levels (high ISO cleanliness codes).

Proper fluid condition is essential for long and satisfactory life of hydraulic components and systems. Hydraulic fluid must have the correct balance of cleanliness, materials, and additives for protection against wear of components, elevated viscosity and inclusion of air.

Essential information on the correct methods for treating hydraulic fluid is included in Eaton publication 561 – “Eaton Guide to Systemic Contamination Control” – Available from your local Eaton distributor. In this publication, filtration and cleanliness levels for extending the life of axial piston pumps and other system components are listed. Included is an excellent discussion of the selection of products needed to control fluid condition.

## Moment of Inertia (single pump rotating group)

Model	Moment of Inertia	
	N-m (sec <sup>2</sup> )	lbf-in (sec <sup>2</sup> )
PVM018	0.0012	0.0104
PVM020	0.0012	0.0104
PVM045	0.0036	0.0320
PVM050	0.0034	0.0300
PVM057	0.0052	0.0457
PVM063	0.0051	0.0447
PVM074	0.0078	0.0691
PVM081	0.0073	0.0643
PVM098	0.0132	0.1165
PVM106	0.0123	0.1086
PVM131	0.0213	0.1889
PVM141	0.0210	0.1856

# Installation and Start-up

**Warning:** Care should be taken that mechanical and hydraulic resonances are avoided in the application of the pump. Such resonances can seriously compromise the life and/or safe operation of the pump.

## Drive Data

Mounting attitude can be either horizontal or vertical, using the appropriate case drain ports to ensure that the case remains full of fluid at all times. Consult your local Eaton Representative if a different arrangement is required.

In those cases where geometric tolerances of mounting are critical, or where specific tolerance ranges are required and not specified, consult Eaton Engineering for specific limits.

Direction of shaft rotation, viewed from the prime mover end, must be as indicated in the model designation on the pump— either right hand (clockwise) or left hand (counterclockwise).

Direct coaxial drive through a flexible coupling is recommended. If drives imposing radial shaft loads are considered, please consult your Eaton Representative.

## Start-up Procedure

Make sure the reservoir and circuit are clean and free of dirt/debris prior to filling with hydraulic fluid.

Fill the reservoir with filtered oil and fill to a level sufficient enough to prevent vortexing at the suction connection to pump inlet. It is good practice to clean the system by flushing and filtering, using an external slave pump.

**Caution:** Before the pump is started, fill the case through the uppermost drain port with hydraulic fluid of the type to be used. The case drain line must be connected directly to the reservoir and must terminate below the oil level.

Once the pump is started, it should prime within a few seconds. If the pump does not prime, check to make sure that there are no restrictions between the reservoir and the inlet to the pump, that the pump is being rotated in the proper direction, and that there are no air leaks in the inlet line and connections. Also check to make sure that trapped air can escape at the pump outlet.

After the pump is primed, tighten the loose outlet connections, then operate for five to ten minutes (unloaded) to remove all trapped air from the circuit.

If the reservoir has a sight gage, make sure the fluid is clear – not milky.

Eaton  
Hydraulics Group USA  
14615 Lone Oak Road  
Eden Prairie, MN 55344  
USA  
Tel: 952-937-9800  
Fax: 952-294-7722  
[www.eaton.com/hydraulics](http://www.eaton.com/hydraulics)

Eaton  
Hydraulics Group Europe  
Route de la Longeraie 7  
1110 Morges  
Switzerland  
Tel: +41 (0) 21 811 4600  
Fax: +41 (0) 21 811 4601

Eaton  
Hydraulics Group Asia Pacific  
Eaton Building  
No.7 Lane 280 Linhong Road  
Changning District, Shanghai  
200335 China  
Tel: (+86 21) 5200 0099  
Fax: (+86 21) 2230 7240