

295ml / 8oz (90mm) Black Double Wall BioCup BC-8DWB-90

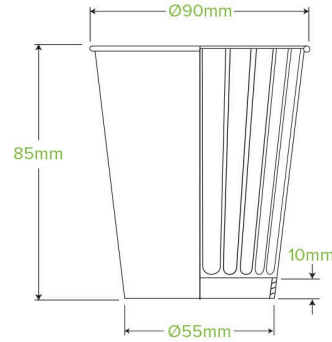

8oz (90mm) Aqueous Double Wall BioCups are manufactured using a unique water-based dispersion coating certified home compostable to Australian standards (AS5810). These cups are food safe, odorless, and can be disposed of right in your backyard compost bin!

Carton quantity: 1000	Sleeves per carton: 20	Units per sleeve: 50
Carton Size LxWxH (cm): 45.5x37.5x62.5	Carton gross weight (kg): 13.476000	Raw material: Paper - FSC™ Mix certified paper
Lining/coating: Aqueous	Window material: None	Printing Type: Offset
Inks: Food Contact Safe Inks	Brim fill capacity (ml): 296	Dimensions top LxW (mm): 90x90
Dimensions base LxW (mm): 54x54	Product Depth: 86	Product weight (g): 12.6
Thickness: 280+260gsm	Use: Hot, Cold, Wet & Dry Products	Manufactured: China
Customise: Print	MOQ custom: 100000	Mould fees: Yes - see custom packaging
Environmental production certified: ISO 14001	Facility Quality Systems: No	Factory food safety certified: BRC
Corporate social accreditation: SMETA	Home compostable: Certified to AS5810 Australian standards, Certified to NF T51-800 European standards	Industrially compostable: Certified to EN13432 European Standards
Recyclable: No		