

4-Compartment Natural Plant Fibre Takeaway Lid B-LBL-4C-N-PF

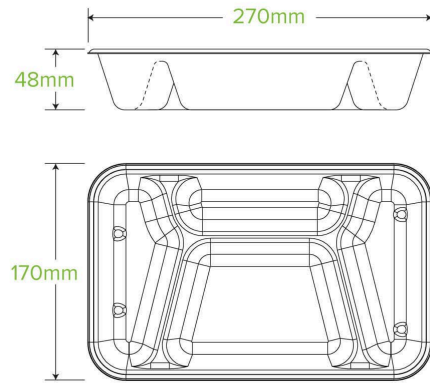

Our plastic-free sugarcane takeaway containers are made from rapidly renewable sugarcane pulp, a by-product of the sugar refining industry, and other plant fibres. They made with no added PFAS and certified home compostable to AS5810 standards. This natural lid fits our 4-compartment bagasse bases (B-LB-4C-N).

| | | |
|---|--|---|
| Carton quantity: 300 | Sleeves per carton: 2 | Units per sleeve: 150 |
| Carton Size LxWxH (cm): 54x44x30 | Carton gross weight (kg): 8.100000 | Raw material: Plant Fibre With No Added PFAS |
| Lining/coating: None | Window material: None | Inks: None |
| Dimensions top LxW (mm): 275x175 | Dimensions base LxW (mm): 275x175 | Product Depth: 15 |
| Product weight (g): 27 | Thickness: 0.6mm | Use: Hot, Cold, Wet & Dry Products |
| Manufactured: China | Customise: Emboss | MOQ custom: MOQ apply see custom packaging |
| Mould fees: Yes - see custom packaging | Environmental production certified: ISO 14001 | Facility Quality Systems: ISO 9001 |
| Factory food safety certified: BRC | Corporate social accreditation: BSCI | Home compostable: Certified to AS5810 Australian standards, Certified to NF T51-800 European standards |
| Industrially compostable: No | Recyclable: No | |