

4-Compartment Natural Plant Fibre Takeaway Base B-LB-4C-N

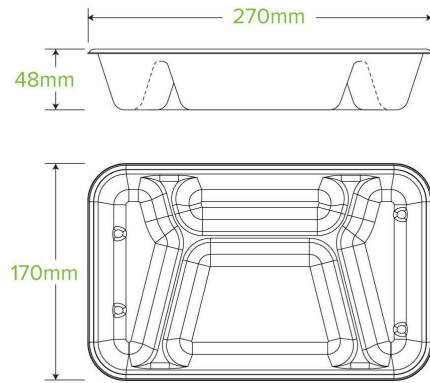

Our plastic-free sugarcane compartment containers are made from rapidly renewable sugarcane pulp, a by-product of the sugar refining industry. This 4-compartment container base is microwave and oven safe.

Carton quantity: 300	Sleeves per carton: 2	Units per sleeve: 150
Carton Size LxWxH (cm): 49x28x36	Carton gross weight (kg): 11.200000	Carton barcode: 19344062033834
Raw material: Plant Fibre With PFAS	Lining/coating: None	Window material: None
Printing Type: None	Inks: None	Brim fill capacity (ml): 1270
Dimensions top LxW (mm): 270	Dimensions base LxW (mm): 170	Product Depth: 48
Product weight (g): 34	Thickness: 0.6mm	Use: Hot, Cold, Wet & Dry Products
Manufactured: China	Customise: Yes - Please Contact Our Team For More Information	MOQ custom: MOQ apply see custom packaging
Mould fees: Yes - see custom packaging	Environmental production certified: ISO 14001	Facility Quality Systems: ISO 9001
Factory food safety certified: BRC	Corporate social accreditation: BSCI	Home compostable: No
Industrially compostable: No	Recyclable: No	