

## 2-Compartment White Plant Fibre Takeaway Base B-LB-2C-W

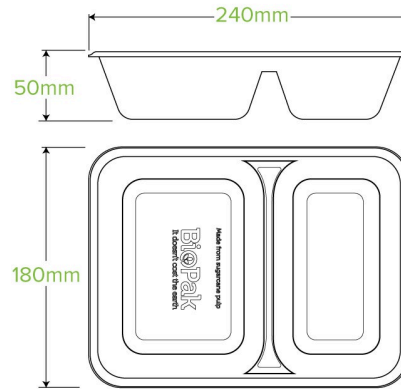

Our plastic-free sugarcane compartment containers are made from rapidly renewable sugarcane pulp, a by-product of the sugar refining industry. This 2-compartment white bagasse food container base is microwave and oven safe.

<b>Carton quantity:</b> 500	<b>Sleeves per carton:</b> 4	<b>Units per sleeve:</b> 125
<b>Carton Size LxWxH (cm):</b> 49x36x38.5	<b>Carton gross weight (kg):</b> 13.500000	<b>Carton barcode:</b> 19344062032967
<b>Raw material:</b> Plant Fibre With PFAS	<b>Lining/coating:</b> None	<b>Window material:</b> None
<b>Printing Type:</b> None	<b>Inks:</b> None	<b>Brim fill capacity (ml):</b> 1230
<b>Dimensions top LxW (mm):</b> 240	<b>Dimensions base LxW (mm):</b> 180	<b>Product Depth:</b> 48
<b>Product weight (g):</b> 28	<b>Thickness:</b> 0.6mm	<b>Use:</b> Hot, Cold, Wet & Dry Products
<b>Manufactured:</b> China	<b>Customise:</b> Yes - Please Contact Our Team For More Information	<b>MOQ custom:</b> MOQ apply see custom packaging
<b>Mould fees:</b> Yes - see custom packaging	<b>Environmental production certified:</b> ISO 14001	<b>Facility Quality Systems:</b> ISO 9001
<b>Factory food safety certified:</b> BRC	<b>Corporate social accreditation:</b> BSCI	<b>Home compostable:</b> No
<b>Industrially compostable:</b> No	<b>Recyclable:</b> No	