

2-Compartment Natural Plant Fibre Takeaway Base B-LB-2C-N-PF

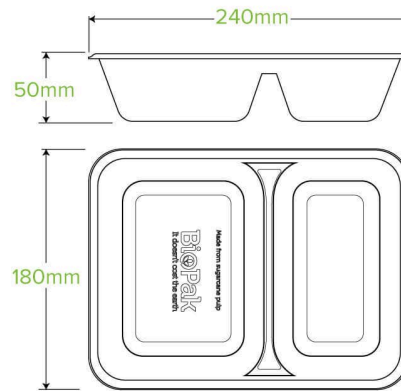

Our plastic-free sugarcane compartment containers are made from rapidly renewable sugarcane pulp, a by-product of the sugar refining industry, and mixed with other plant fibres. This 2-compartment natural food container base is microwave and oven safe. Made with no added PFAS and pending home compostable to AS5810 standards.

Carton quantity: 500	Sleeves per carton: 4	Units per sleeve: 125
Carton Size LxWxH (cm): 49x36x38.5	Carton gross weight (kg): 12.500000	Raw material: Plant Fibre With No Added PFAS
Lining/coating: None	Window material: None	Inks: None
Brim fill capacity (ml): 1230	Dimensions top LxW (mm): 240x180	Dimensions base LxW (mm): 190x130
Product Depth: 48	Product weight (g): 25	Use: Hot, Cold, Wet & Dry Products
Manufactured: China	Customise: Yes - Please Contact Our Team For More Information	MOQ custom: 250000
Mould fees: Yes - see custom packaging	Environmental production certified: ISO 14001	Facility Quality Systems: ISO 9001
Factory food safety certified: BRC	Corporate social accreditation: BSCI	Home compostable: Certified to AS5810 Australian standards, Certified to NF T51-800 European standards
Industrially compostable: No	Recyclable: No	