

## 255ml / 8oz (80mm) Stone Double Wall Biocup ABC-8DW

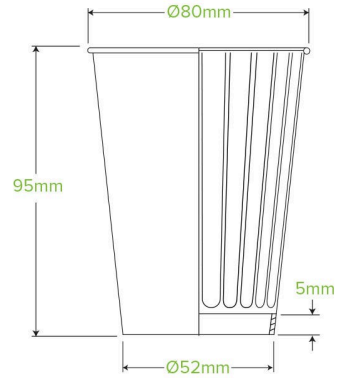

8oz Aqueous Double Wall BioCups are manufactured using a unique water-based dispersion coating certified home compostable to Australian standards (AS5810). These cups are food safe, odorless, and can be disposed of right in your backyard compost bin!

<b>Carton quantity:</b> 1000	<b>Sleeves per carton:</b> 20	<b>Units per sleeve:</b> 50
<b>Carton Size LxWxH (cm):</b> 40.5x32.5x62	<b>Carton gross weight (kg):</b> 13.730000	<b>Carton barcode:</b> 19344062063879
<b>Raw material:</b> Paper - FSC™ Mix certified paper	<b>Lining/coating:</b> Aqueous	<b>Window material:</b> None
<b>Printing Type:</b> Offset	<b>Inks:</b> Food Contact Safe Inks	<b>Brim fill capacity (ml):</b> 260
<b>Dimensions top LxW (mm):</b> 80x80	<b>Dimensions base LxW (mm):</b> 49x49	<b>Product Depth:</b> 96
<b>Product weight (g):</b> 12.8	<b>Thickness:</b> 280+260gsm	<b>Use:</b> Hot, Cold, Wet & Dry Products
<b>Manufactured:</b> China	<b>Customise:</b> Print	<b>MOQ custom:</b> 100000
<b>Mould fees:</b> Yes - see custom packaging	<b>Environmental production certified:</b> ISO 14001	<b>Facility Quality Systems:</b> No
<b>Factory food safety certified:</b> BRC	<b>Corporate social accreditation:</b> SMETA	<b>Home compostable:</b> Certified to AS5810 Australian standards, Certified to NF T51-800 European standards
<b>Industrially compostable:</b> Certified to EN13432 European Standards	<b>Recyclable:</b> No	