

120ml / 4oz (63mm) Stone Single Wall BioCup ABC-4

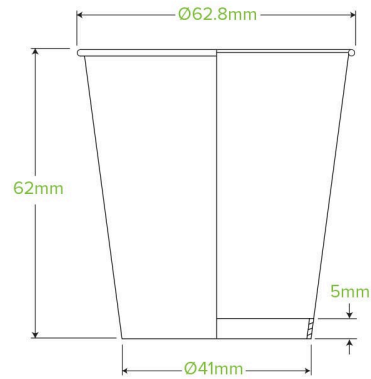

4oz Aqueous Single Wall BioCups are manufactured using a unique water-based dispersion coating certified home compostable to Australian standards (AS5810). These cups are food safe, odorless, and can be disposed of right in your backyard compost bin!

Carton quantity: 2000	Sleeves per carton: 40	Units per sleeve: 50
Carton Size LxWxH (cm): 50.5x31.5x34	Carton gross weight (kg): 7.840000	Carton barcode: 19344062062292
Raw material: Paper - FSC™ Mix certified paper	Lining/coating: Aqueous	Window material: None
Printing Type: Offset	Inks: Food Contact Safe Inks	Brim fill capacity (ml): 120
Dimensions top LxW (mm): 62x62	Dimensions base LxW (mm): 45x45	Product Depth: 62.5
Product weight (g): 3.5	Thickness: 230gsm	Use: Hot, Cold, Wet & Dry Products
Manufactured: China	Customise: Print	MOQ custom: 100000
Mould fees: Yes - see custom packaging	Environmental production certified: ISO 14001	Facility Quality Systems: No
Factory food safety certified: BRC	Corporate social accreditation: SMETA	Home compostable: Certified to AS5810 Australian standards, Certified to NF T51-800 European standards
Industrially compostable: Certified to EN13432 European Standards	Recyclable: No	