

# Horizontal Tee

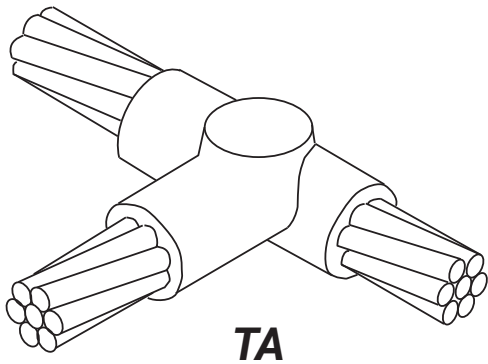

## HORIZONTAL TEE CONNECTIONS

Tee of horizontal run and tap cables.

- Concentric stranded copper cable unless otherwise noted.
- Solid conductor can be copper or Copperweld.
- **Bold letter** in mould part number is the price key.

## REQUIRED TOOLS

	Article No.	Part No.
Handle Clamps		
for C Price Key Moulds	161000	L160
for D Price Key Moulds	161020	L159
Cadweld Plus Control Unit or	165738	PLUSCU
Flint Ignitor	165000	T320

## SUGGESTED TOOLS

Conductor Cleaning Brush	165130	T313
Slag Removal Spade		
#65 w/m & smaller	181225	B136A
#90 w/m & larger	181230	B136B
Mould Cleaning Brush	165260	T394
Cable Clamp	165020	B265
Torch Head	140160	T111

## TA

CABLE SIZE (sq mm) run		MOULD PART NO. tap	WELDING MATERIAL <sup>1</sup>
16*	16*	TACW3W3	32
25	25	TAC <b>Y</b> 1Y1	32
25	16*	TAC <b>Y</b> 1W3	45
35	35	TAC <b>Y</b> 2Y2	45
35	25	TAC <b>Y</b> 2Y1	45
35	16*	TAC <b>Y</b> 2W3	45
50	50	TAC <b>Y</b> 3Y3	90
50	35	TAC <b>Y</b> 3Y2	45
50	25	TAC <b>Y</b> 3Y1	45
50	16*	TAC <b>Y</b> 3W3	45
70	70	TAC <b>Y</b> 4Y4	90
70	50	TAC <b>Y</b> 4Y3	90
70	35	TAC <b>Y</b> 4Y2	45
70	25	TAC <b>Y</b> 4Y1	45
70	16*	TAC <b>Y</b> 4W3	45
95	95	TAC <b>Y</b> 5Y5	115
95	70	TAC <b>Y</b> 5Y4	90
95	50	TAC <b>Y</b> 5Y3	90
95	35	TAC <b>Y</b> 5Y2	90
95	25	TAC <b>Y</b> 5Y1	90
95	16*	TAC <b>Y</b> 5W3	90

CABLE SIZE (sq mm) run		MOULD PART NO. tap	WELDING MATERIAL <sup>1</sup>
95	16*	TAC <b>Y</b> 5W3	90
120	120	TAC <b>Y</b> 6Y6	150
120	95	TAC <b>Y</b> 6Y5	150
120	70	TAC <b>Y</b> 6Y4	90
120	50	TAC <b>Y</b> 6Y3	90
120	35	TAC <b>Y</b> 6Y2	90
150	150	TAC <b>Y</b> 7Y7	200
150	120	TAC <b>Y</b> 7Y6	150
150	95	TAC <b>Y</b> 7Y5	150
150	70	TAC <b>Y</b> 7Y4	90
185	185	TAC <b>Y</b> 8Y8	200
185	150	TAC <b>Y</b> 8Y7	200
185	120	TAC <b>Y</b> 8Y6	200
240	240	TAC <b>Y</b> 9Y9	2 x 150**
240	185	TAC <b>Y</b> 9Y8	200
240	150	TAC <b>Y</b> 9Y7	200
240	120	TAC <b>Y</b> 9Y6	200
8 mm Ø	8 mm Ø	TACW6W6	90
10 mm Ø	8 mm Ø	TACW8W6	90
10 mm Ø	10 mm Ø	TACW8W8	90

\*Packing: B112, sleeve

<sup>1</sup> For Cadweld Plus add suffix "PLUSF20" (refer page 8)

<sup>1</sup> For Cadweld Plus add suffix "PLUSF20" (refer page 8)

\*\*For Cadweld Plus use 300PLUSF20