

IEK-25-PIPE AND IEK-25-04

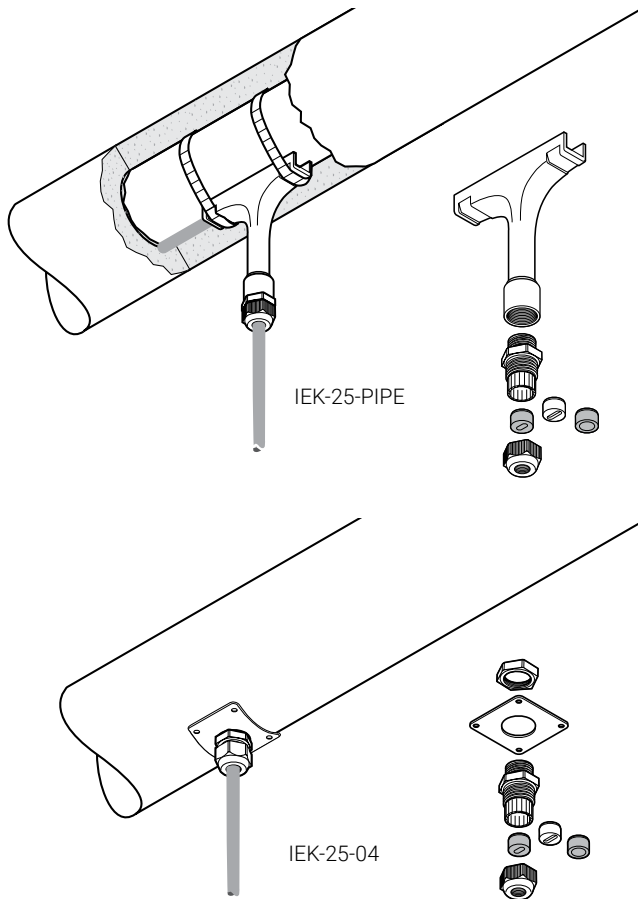

RAYCHEM

INSULATION ENTRY KIT



Insulation entry kits are designed to protect cables when passing through the thermal insulation cladding. The IEK's are suitable for all type of parallel heating cables as well as power cables. Insulation entry kits may be used in hazardous and non hazardous areas.

The gland and the grommet provided in the kit provide strain relief and environmental sealing to avoid water ingress in the insulation.

The nVent RAYCHEM IEK-25-PIPE contains a protective guiding tube which is fixed to the pipe and allows the heat-tracing installation to be completed independently from the insulation work. The nVent RAYCHEM IEK-25-04 contains a stainless steel plate which can be screwed to the cladding.

Insulation entry kits can be used for installations on pipes, tanks and vessels etc.

APPLICATION

IEK-25-PIPE

Insulation entry kit for pipe mounting for heating- and power cables with an outside diameter in the range of 8 to 17 mm.

Kit contains 1 pc.

IEK-25-04

Insulation entry kit for pipes, tanks and vessels. Usable for all types of polymer heating cables and power cables with an outside diameter in the range of 8 to 17 mm.

Kit contains 1 pc.

KIT CONTENTS

1 x polymer "T" Tube
1 x plastic gland (M25) with round hole grommet for power cables
1 x bag with 2 silicon grommets for heating cables

1 x stainless steel fixing plate
1 x plastic gland (M25) with round hole grommet for power cables
1 x bag with 2 silicon grommets for heating cables
1 x locknut

PROUDLY DISTRIBUTED BY

GVK Kinsman
ELECTRICAL DISTRIBUTOR PTY LTD

Web www.gvk.com.au
Email sales@gvk.com.au
Phone 03 9312 6633
Fax 03 9312 6433

PRODUCT SPECIFICATIONS

IEK-25-PIPE	IEK-25-04	
Max. exposure temp.		
gland	110°C	110°C
tube	260°C	–

APPROVALS

DNV Certificate No. E-11564 and E-11565

DIMENSIONS

Height 135 mm, width 120 mm Plate 60 x 60 mm (22SWG)

ORDERING INFORMATION

Part number (Weight) 1244-001050 (0.13 kg) 332523-000 (0.06 kg)

PROUDLY DISTRIBUTED BY



Web www.gvk.com.au

Email sales@gvk.com.au

Phone 03 9312 6633

Fax 03 9312 6433



Our powerful portfolio of brands:

CADDY ERICO HOFFMAN RAYCHEM SCHROFF TRACER