

neo  
for iwata

---

NEO SERIES MANUAL

*Congratulations on your purchase of a*

**neo**  
for **iwata**  
*airbrush.*

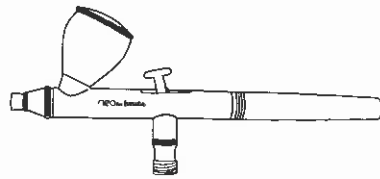

**CN GRAVITY-FEED  
DUAL-ACTION AIRBRUSH**

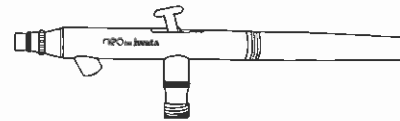

**BCN SIPHON-FEED  
DUAL-ACTION AIRBRUSH**

3

### ASSEMBLY

1. Screw the airhose onto the airbrush (Iwata airhose sold separately).
2. Screw the airhose onto the compressor.

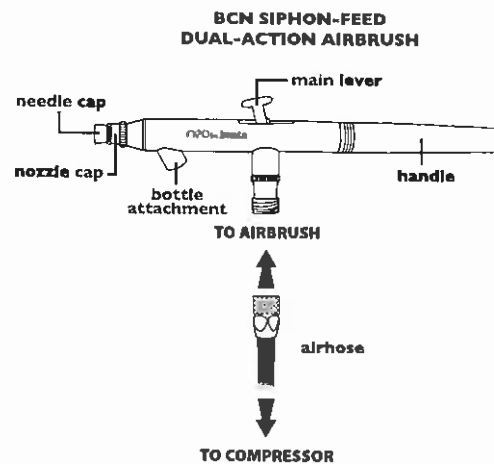
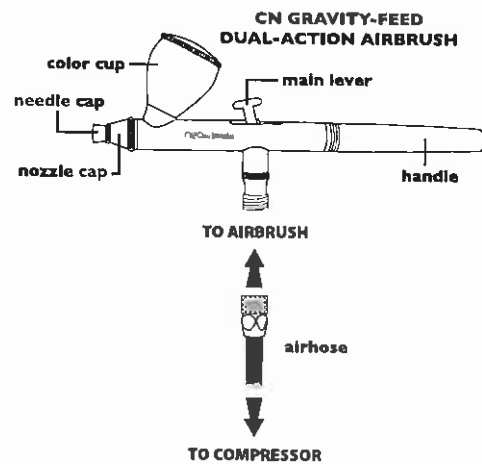

## GENERAL OPERATION - REFER TO DIAGRAM ON PAGE 3

### Fine-Line Spray

1. Depress the main lever to start air flow.
2. Position the airbrush close to the surface, between 1/16 and 1/2 inch is common.
3. Pull the main lever back slightly to start the flow of paint.

Line thickness can be controlled by adjusting the distance between the airbrush and the surface and also by varying the paint flow by manipulating the main lever's position.

### Wide-Line and Background Spraying

1. Depress the main lever.
2. Position the airbrush further away from the surface, from 1 to 6 inches is common.
3. Pull the main lever back much farther releasing more paint to cover the bigger area.

Increase the distance between the airbrush and painted surface to control the line's width. Increasing the air pressure will also affect the spray width.

### Air Pressure

For the NEO, working pressures generally vary between 10 and 60 psi, depending on what type of work is being done and what textures are desired. A good working pressure

may average around 15-25 psi. The viscosity of the paint and your desired spray characteristics will also affect your ideal pressure. As a general rule, larger amounts of paint or thicker paints, will be sprayed with higher pressures.

**WARNING: Do not exceed 100psi.**

### Paint Preparation

For non-airbrush-ready paints, proper preparation, including filtering the paint through a nylon mesh, is recommended for best performance. Paint should be thinned with its proper solvent. It is best to prepare paint relatively thin and make repeated passes across the work to achieve the desired shade. This will also improve the quality of your work and decrease the cleaning time of your airbrush.

### Safety Tips

- Always spray in a well-ventilated area.
- Do not spray solvent-based (flammable) paints around open flames.
- Use the appropriate respirator to safely filter out the paint vapors particular to the kind of paint you are using.
- Wear eye protection to prevent paint contact with eyes.
- Never use air pressure that exceeds the airbrush's limit (100 psi)

**Cleaning the Airbrush (BCN)**

1. Remove the paint bottle.
2. Attach a bottle containing the appropriate cleaning solution. (Note: Medea Airbrush Cleaner works great for water-based media.)
3. Spray until the solution sprays clear.
4. Remove the bottle of cleaning solution.
5. Spray air until the airbrush sprays dry.
6. Attach a bottle containing the next color.
7. Repeat cleaning procedure when finished.

**Cleaning the Airbrush (CN)**

1. Dump out the color cup's excess paint.
2. Rinse the cup with the appropriate cleaning solution. (Note: Medea Airbrush Cleaner works great for water-based media.)
3. Use a paper towel to wipe out any left-over paint.
4. Fill the bottom of the cup with cleaner.
5. Spray cleaner until the spray is clear.
6. Add the next color to the color cup.
7. Repeat cleaning procedure when finished.

**Cleaning the Needle (BCN, CN)**

Before removing the needle, clean the airbrush as recommended.

1. Unscrew the handle from the airbrush body.
2. Loosen the needle chucking nut.
3. Gently pull the needle straight out.
4. Fold a soft cloth damp with cleaner over the needle.
5. Rotate the needle to gently wipe the residual paint off.
6. Carefully insert the needle into the airbrush until it seats fully against the nozzle.

**CAUTION: The most probable time to damage the needle is when the needle passes through the main lever. If the needle stops abruptly, retract and examine the trigger mechanism for proper assembly and re-insert the needle.**

7. Tighten the needle chucking nut finger tight.
  - Pull the main lever back and forth to visually confirm the needle's ability to move.
8. Screw the handle back onto the airbrush body.

## MAINTENANCE - REFER TO DIAGRAM/PARTS GUIDE ON PAGES 7-8 (CONT'D)

### Before Each Session

Spray water or the appropriate cleaning solution through the airbrush to make sure the airbrush is working properly.

### After Each Session

Or any time the airbrush becomes clogged:

1. Increase the air pressure.
2. Spray cleaning solution for a short time.
3. Clean the needle if necessary.

Cleaning the airbrush this way helps clean the paint passage, the nozzle and the needle thoroughly.

### Periodically

To ensure smooth main lever action lubricate the needle and the main lever mechanism when necessary.

1. Unscrew the handle.
2. Loosen the needle chucking nut.
3. Remove the needle.
4. Coat the needle lightly at the front where the taper starts with a high-quality lubricant, like Medea Super Lube.
5. Wipe the needle with a soft, clean cloth, leaving a light coat of lube behind.

6. Re-insert the needle gently into the airbrush.
7. Tighten the needle chucking nut.
8. Screw the handle onto the airbrush body.

Use a tiny drop of lube on the main lever's piston. DO NOT over-lube the needle or the main lever mechanism, since it is possible to transfer excess lube into the nozzle causing severe paint flow problems. DO NOT use light machine oil or WD-40 for lubrication. These will cause the needle to stick as it moves through the needle packing o-ring.

**CAUTION: If it becomes absolutely necessary to dismantle the airbrush remember that in most situations tools are not needed.**

7

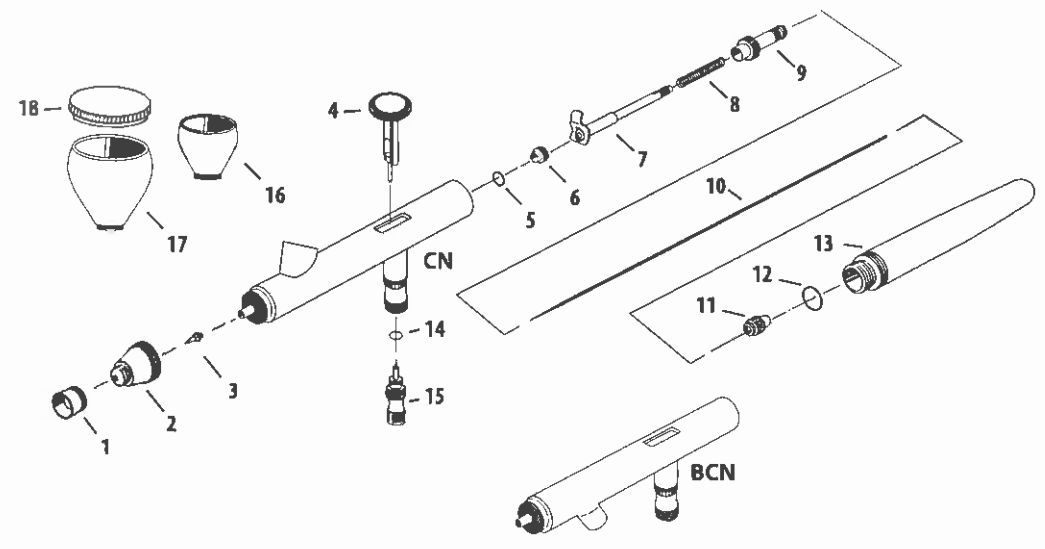

— NEO SERIES FOR IWATA AIRBRUSHES • MASTER PARTS LIST —

#	Code#	Part Name	BCN	CN
1	N 110 1	Needle Cap	■	■
2	N 140 1	Nozzle Cap	0.35-mm	opt ■
	N 140 2		0.5-mm	■ opt
3	N 080 1	Nozzle	0.35-mm	opt ■
	N 080 2		0.5-mm	■ opt
4	N 100 1	Main Lever	■	■
5	N 150 1	Needle Packing O-Ring	■	■
6	N 125 1	Needle Packing Screw	■	■
7	N 115 1	Needle Chucking Guide	■	■
8	N 135 1	Needle Spring	■	■
9	N 170 1	Spring Guide	■	■

#	Code#	Part Name	BCN	CN
10	N 075 1	Needle	0.35-mm	opt ■
	N 075 2		0.5-mm	■ opt
11	N 120 1	Needle Chucking Nut	■	■
12	N 105 1	Handle O-Ring	■	■
13	N 090 1	Handle	■	■
14	N 150 2	Valve Body O-Ring	■	■
15	N 020 1	Valve Set	■	■
16	N 070 1	Fluid Cup	1/4 oz.	x ■
17	N 070 2	Fluid Cup	1/2 oz.	x ■
18	N 095 4	Fluid Cup Lid		x ■

■ = yes x = no opt = optional



**Nozzle**

In time, the nozzle may wear or be damaged and may need to be replaced.

1. Unscrew the handle.
2. Loosen the needle chucking nut.
3. Gently pull the needle part way back. It doesn't need to be fully pulled out.
4. Unscrew the needle cap and the nozzle cap.
5. Unscrew the nozzle counter-clockwise with the provided wrench.
6. Screw the new nozzle into the airbrush body with your fingers.
7. Slightly tighten the nozzle with the provided wrench.
  - DO NOT OVER TIGHTEN!
8. Screw the needle cap and nozzle cap onto the airbrush body.
9. Push the needle all the way forward until it seats with the new nozzle.
10. Tighten the needle chucking nut.
11. Screw the handle onto the airbrush body.

**TIP: Keep a spare nozzle on hand for unforeseen accidents.**

**Needle**

Needles are subject to easy physical damage because of the long tapered, extremely fine tip. If the needle point becomes severely bent, it must be straightened before pulling it back through the nozzle. If not, the bent needle might damage the nozzle as it's pulled through.

**TIP: Keep a spare needle on hand for unforeseen accidents.**

All NEO for Iwata airbrushes are *Warranted* against all manufacturing defects of material and manufacture or workmanship for a period of FIVE years from the date of purchase. This warranty does not cover fluid needles or fluid nozzles since these parts need to be replaced occasionally due to normal wear. Any other part or material that is or becomes defective so as not to be usable within this period will be repaired or replaced. This warranty does not cover damage caused by negligence or airbrushes that have been altered or abused in any way. Call or email Iwata-Medea before returning an airbrush for the appropriate procedure for warranty repairs.





— [www.IWATANEQ.com](http://www.IWATANEQ.com) —

**ANEST IWATA-MEDEA, Inc.** • 1336 N. Mason St., Portland, OR 97217

tel: 503-253-7308 • fax: 503-253-0721 • [info@iwata-medea.com](mailto:info@iwata-medea.com)

rev3