



CT23AU12/L

Double DIN Fitting Kit for Audi (Non-MMI) Vehicles



IN THE KIT

- i. Double DIN Fascia Panel*
- ii. Brackets
- iii. Hex Screws (x8)

**Note the fascia panel showcased throughout this instruction manual is for Right hand vehicles. The procedure is identical for Left hand vehicles, although you will need to use the CT23AU12L fascia panel during installation.*

APPLICATION

Note: Application data is subject to change at any time

- A4 (8K) 2008 - 2015
- A5 (8TF, 8F7, 8TA) 2008 - 2015

RECOMMENDED TOOLS

- Panel Removal Tool
- Pick Tool
- Screwdriver
- 8mm Socket Wrench

FEATURES

- Allows for the installation of a double DIN aftermarket stereo
- Includes mounting brackets and fitting accessories
- Finished in matt black to match vehicle dashboard

DISCLAIMER

The information provided in this document is subject to change without notice due to manufacturer changes and/or improvements to the product/s. This instruction manual is based on documented data and research. The manufacturer of this product cannot be held responsible for any changes made to the vehicle by the manufacturer or damages that may occur through the installation of this product in accordance with the steps outlined herein.

OVERVIEW DIAGRAM

- 1 Double DIN Fascia Panel
- 2 Left/Right Brackets

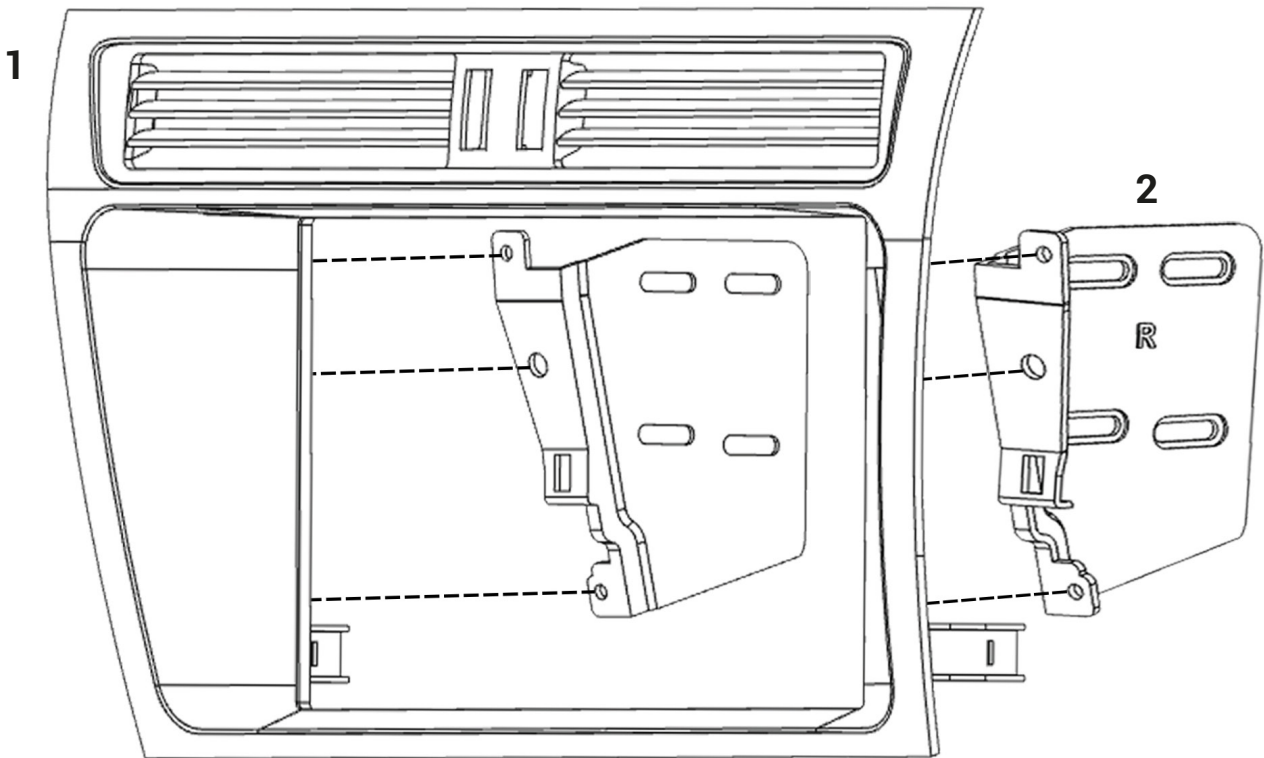

PRIOR TO INSTALLATION

Read the manual prior to installation. Technical knowledge is necessary for installation. The place of installation must be free of moisture and away from heat sources. Please ensure that the correct tools are used during the installation to avoid damage to the vehicle or product. **Connects2 can not be held responsible for the installation of this product.**

How to tell if your vehicle is 'MMI'



..... Audi with MMI



..... Audi without MMI

INSTALLATION GUIDE



Audi Non-MMI OEM dashboard.
Ensure that appropriate areas of the dashboard are protected by a suitable material to avoid damage during installation.

DASH DISASSEMBLY

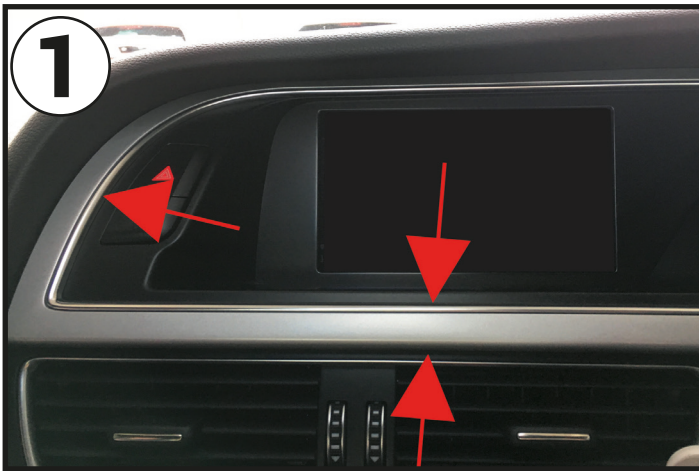

Begin by using a Bojo tool (or similar variant) to pry away and unclip the trim that surrounds the top screen. Once loose, disconnect the hazard switch connector and place to one side.

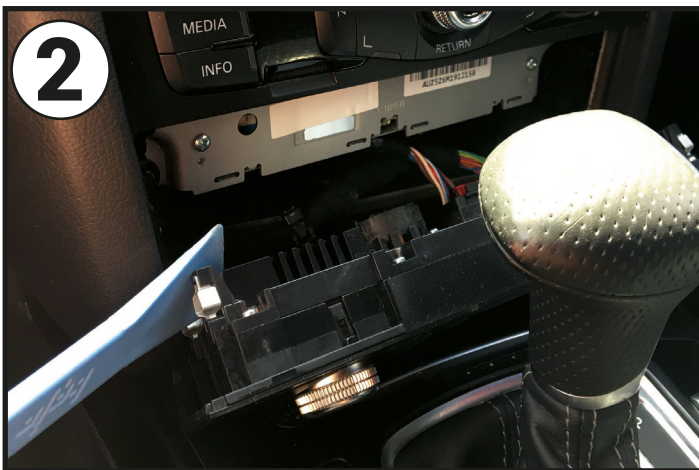

Using the Bojo tool again, pry away and unclip the bottom HVAC panel. Once loose, disconnect the panel connectors and place to one side.



Using a pick tool, insert it in between the fan blades and release the spring clips. Once free, remove and place into storage.

DASH DISASSEMBLY



Using a pair of radio release keys (e.g. CT22AU01) remove the head unit. When free, disconnect all the wiring.

KIT ASSEMBLY

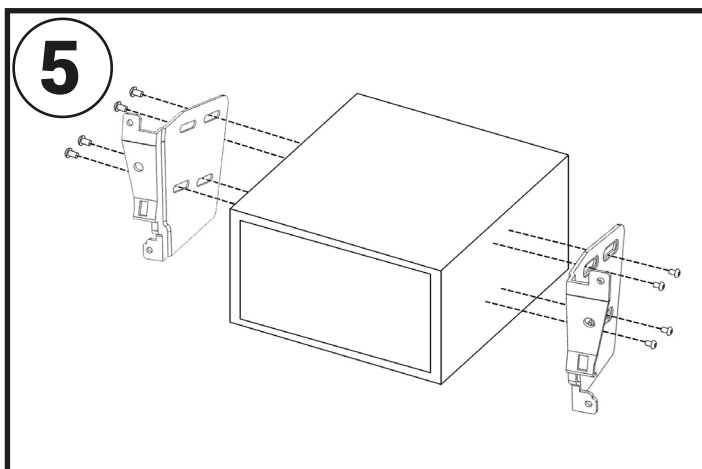

Attach the new Double DIN Brackets to the aftermarket head unit utilising the screws within the kit.

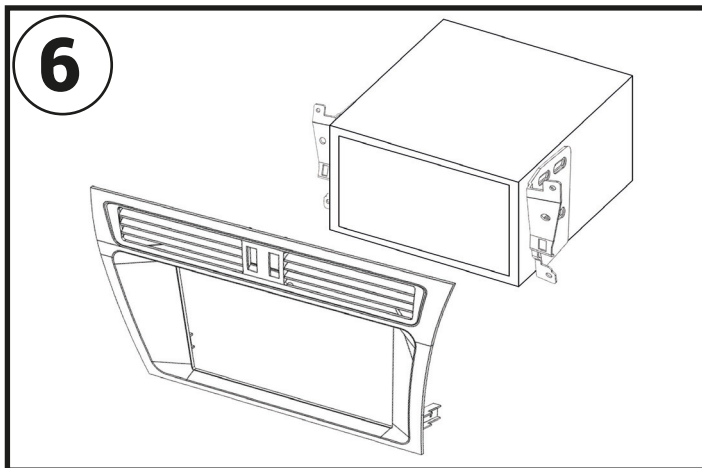

With the brackets attached to the head unit, offer the whole unit to the back of the new Double DIN Fascia. Use the plastic inserts at the bottom of both the Brackets and the Fascia as a guide.



After connecting all the necessary wiring, begin to install the new Double DIN Fascia with the aftermarket head unit into the dashboard. Firmly press down around the edges to ensure it clips into place - this will complete the installation.