



# Chrysler 200 LX (with a 3.0" screen) 2015-up Jeep Cherokee Sport 2014-up Ram Trucks (without 8.4 inch touchscreen) 2013-up 99-6518B

## KIT FEATURES

- ISO DIN radio provision with pocket
- **Painted matte black**
- **Note:** Modifications to factory radio cavity is required for this installation



## KIT COMPONENTS

- A) Radio housing • B) Brackets • C) Pocket • D) (4) #8 x 3/8" Phillips screws

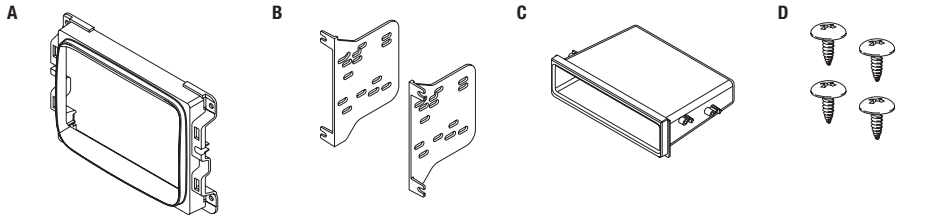

## WIRING & ANTENNA CONNECTIONS (sold separately)

Wiring Harness: • XSVI-6523-NAV • AX-LCD

Antenna Adapter: • 40-EU55

## Table of Contents

### Dash Disassembly

- Chrysler 200 LX (with a 3.0" screen) 2015-up..... 2
- Jeep Cherokee Sport 2014-up .....3-4
- Ram Trucks 2013-up..... 5

### Kit Assembly

- ISO DIN radio provision with pocket..... 6

## TOOLS REQUIRED

- Panel removal tool • Phillips screwdriver
- 9/32 Socket removal tool

**CAUTION!** Metra recommends disconnecting the negative battery terminal before beginning any installation, unless the vehicle manufacturer recommends against so. Please check with your local Dealership for more information. All accessories, switches, climate controls panels, and especially air bag indicator lights must be connected before reconnecting the battery or cycling the ignition. Also, do not remove the factory radio with the key in the on position, or the vehicle running. It would be best to remove the key from the ignition and then wait a few seconds before removing the factory radio.

REV. 11/14/2017 INST99-6518B

## Dash Disassembly

### Chrysler 200 LX (with a 3.0" screen) 2015-up

1. Unclip the radio trim bezel from the vehicle. (Figure A)
2. Remove (4) screws securing the radio to the dash, disconnect the connectors attached, and then remove the radio.

*Continue to kit assembly*

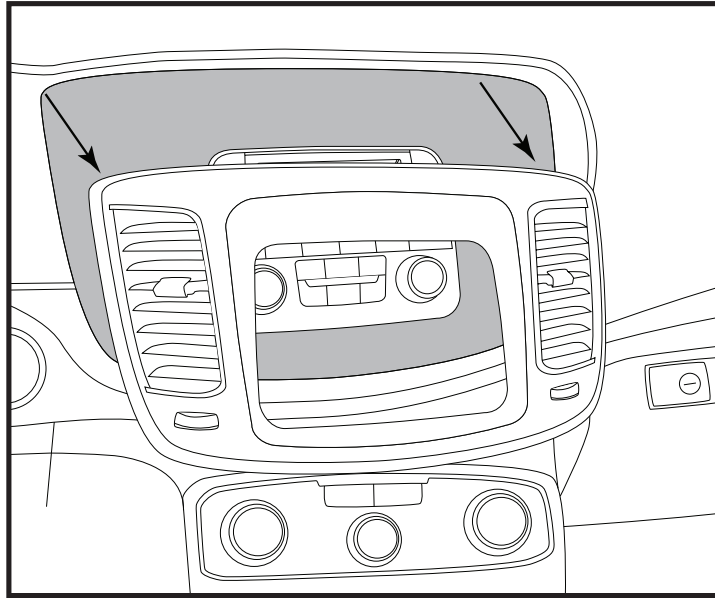

(Figure A)

## Dash Disassembly Jeep Cherokee Sport 2014-up

1. Unclip and remove the climate control panel from the vehicle and put to the side. (Figure A)
2. Remove (2) screws securing the radio trim bezel to the dash. (Figure B)
3. Unclip the radio trim bezel from the vehicle. (Figure C)
4. Remove (4) screws securing the radio to the dash, disconnect the connectors attached, and then remove the radio.  
*Continue on next page*

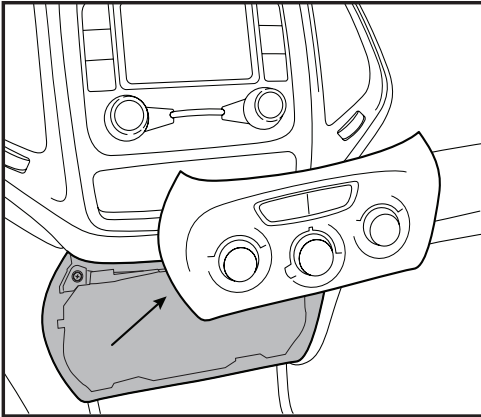

(Figure A)

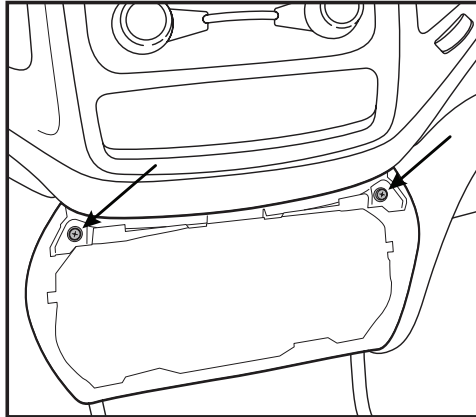

(Figure B)

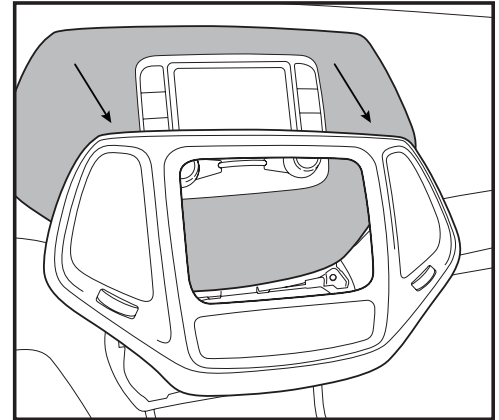

(Figure C)

## Dash Disassembly Jeep Cherokee Sport 2014-up (Continued)

### Sub-dash modification:

1. Remove the rubber cover from inside the pocket on top of the dash, and then remove (1) screw exposed.
2. Remove (2) screws below the radio cavity. (Figure A)
3. From inside the radio cavity, remove (2) screws securing the metal, radio sub-dash bracket, and then discard. (Figure B)
4. Carefully cut the plastic from the bottom rear portion of the radio cavity, down to the metal brace. (Figure C)

*Continue to kit assembly*

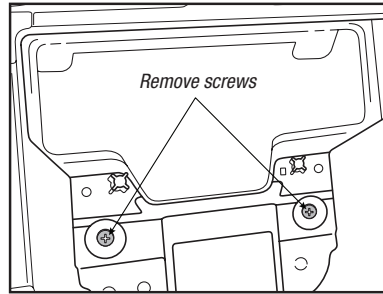

(Figure A)

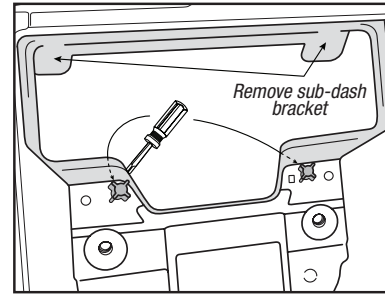

(Figure B)

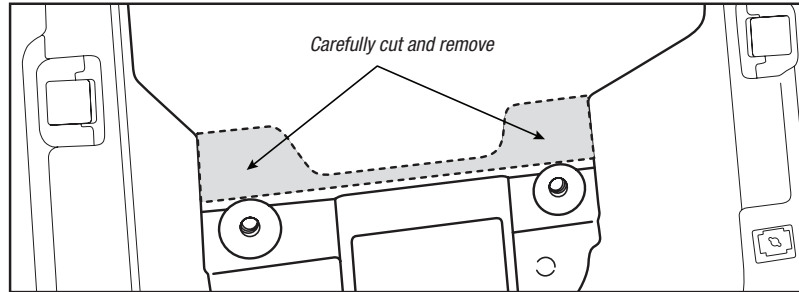

(Figure C)

## Dash Disassembly

### Ram (without a 8.4 inch touchscreen) 2013-up

1. Remove liner inside tray at the top center of the dash and remove (2) torx screws. (Figure A)
2. Unsnap and remove radio panel. (Figure B)
3. Remove four screws and remove radio. (Figure C)
4. The factory rear support will need to be cut or removed to allow space for a new radio. The bottom section can be removed with two cuts at the bottom corners. (Figure D)

*Continue to kit assembly*

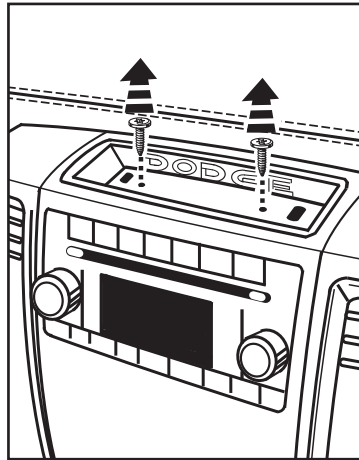

(Figure A)

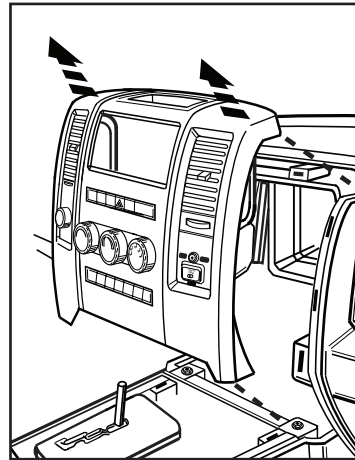

(Figure B)

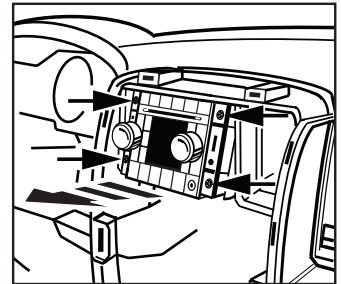

(Figure C)

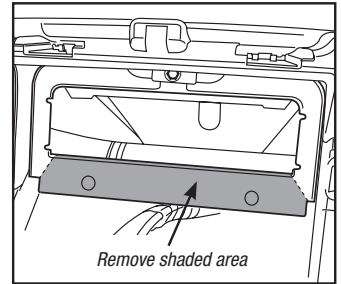

(Figure D)

## Kit Assembly

### ISO DIN radio provision

**Note:** For proper orientation, the locating tabs on the radio housing are more to the top of the kit than bottom. (Figure A)

1. Rotate the brackets into the radio housing. (Figure B)
2. Mount the Pocket inside the brackets using the supplied #8 x 3/8" screws. (Figure C)
3. Slide the radio into the bracket/pocket/ radio housing assembly and secure using the screws supplied with the radio. (Figure D)
4. Locate the factory wiring harness and antenna plug in the dash. Metra recommends using the proper mating adapters from Metra and/or AXCESS.
5. Reassemble the dash in reverse order of disassembly.

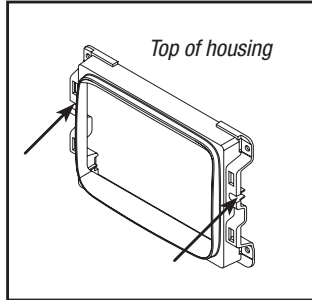

(Figure A)

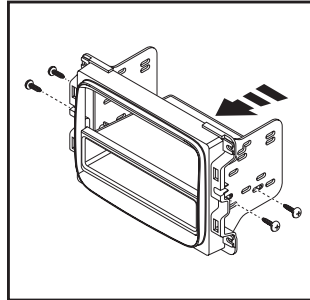

(Figure C)

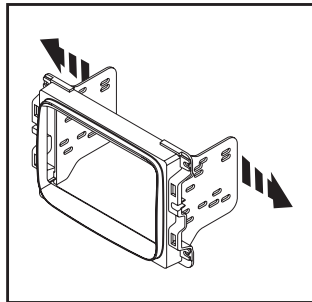

(Figure B)

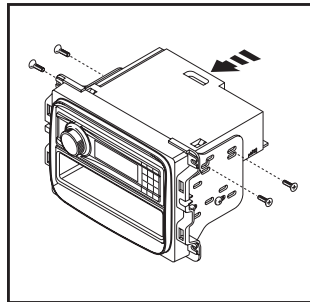

(Figure D)



99-6518B

## Notes

---

---

---

---

---

---

---

---

---

---

---

---

---

---

---



Installation instructions for 99-6518B



REV 11/14/2017 INST99-6518B

## IMPORTANT

If you are having difficulties with the installation of this product, please call our Tech Support line at **1-800-253-TECH**. Before doing so, look over the instructions a second time, and make sure the installation was performed exactly as the instructions are stated. Please have the vehicle apart and ready to perform troubleshooting steps before calling.



### KNOWLEDGE IS POWER

Enhance your installation and fabrication skills by enrolling in the most recognized and respected mobile electronics school in our industry. Log onto [www.installerinstitute.com](http://www.installerinstitute.com) or call 800-354-6782 for more information and take steps toward a better tomorrow.



**Metra recommends MECP certified technicians**



# Chrysler 200 LX (con pantalla de 3.0") 2015 y mas Jeep Cherokee Sport 2014 y mas Ram Trucks (sin pantalla táctil de 8.4) 2013 y mas 99-6518B

## CARACTERÍSTICAS

- Provisión de radio ISO DIN con cavidad
- **Pintura negro mate**
- **Nota:** Se requieren modificaciones a la cavidad del radio de fábrica para esta instalación.



## COMPONENTES DEL KIT

- A) Carcasa del radio • B) Soportes • C) Cavidad • D) (4) tornillos Phillips #8 de 3/8"

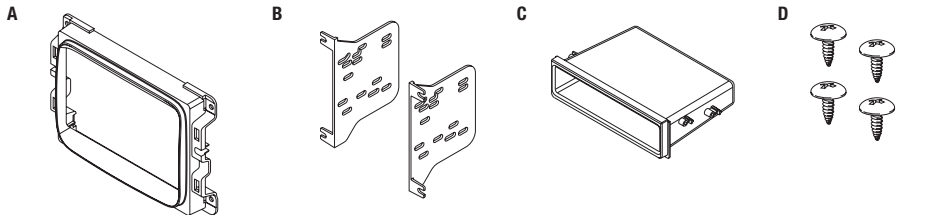

## CABLEADO Y CONEXIONES DE ANTENA (se venden por separado)

Arnés de cableado: • XSVI-6523-NAV • AX-LCD

Adaptador de antena: • 40-EU55

## Indice

### Desmontaje Dash

- Chrysler 200 LX (con pantalla de 3.0") 2015 y mas2
- Jeep Cherokee Sport 2014 y mas .....3-4
- Ram Trucks 2013 y mas..... 5

### Ensamble del kit

- Provisión de radio ISO DIN con cavidad ..... 6

## HERRAMIENTAS REQUERIDAS

- Herramienta de remoción de panel
- Destornillador Phillips
- Herramienta de remoción de casquillo 9/32

**¡PRECAUCIÓN!** Meta recomienda desconectar la terminal negativa de la batería antes de iniciar cualquier instalación, a menos que el fabricante del vehículo recomiende lo contrario. Verifique con su concesionario local si existe más información. Todos los accesorios, interruptores, paneles de controles de clima y especialmente las luces del indicador de las bolsas de aire deben estar conectados antes de reconectar la batería o ciclar la ignición. Además, no quite el radio de fábrica con la llave en la posición de encendido ni con el vehículo funcionando. Sería mejor retirar la llave de la ignición y esperar unos cuantos segundos antes de quitar el radio de fábrica.

## Desmontaje Dash

### Chrysler 200 LX (con pantalla de 3.0") 2015 y mas

1. Desenganche el bisel de la moldura del radio del vehículo. (Figura A)
2. Retire los (4) tornillos que sujetan el radio a tablero, desconecte los conectores unidos y luego quite el radio.

*Continúe con el ensamble del kit*

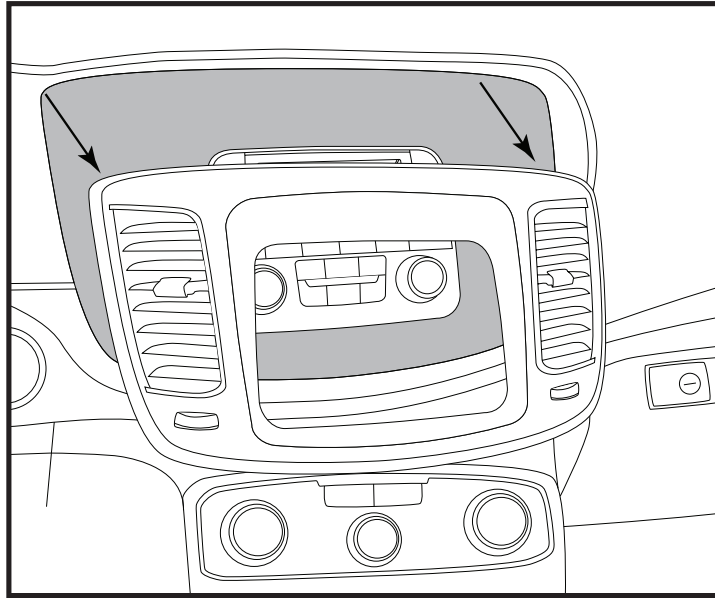

(Figura A)

## Desmontaje Dash Jeep Cherokee Sport 2014 y mas

1. Desenganche y quite el panel del control del clima del vehículo y póngalo a un lado. (Figura A)
2. Quite los (2) tornillos que sujetan el bisel de la moldura del radio al tablero. (Figura B)
3. Desenganche el bisel de la moldura del radio del vehículo. (Figura C)
4. Retire los (4) tornillos que sujetan el radio a tablero, desconecte los conectores unidos y luego quite el radio.  
*Continúa en la página siguiente*

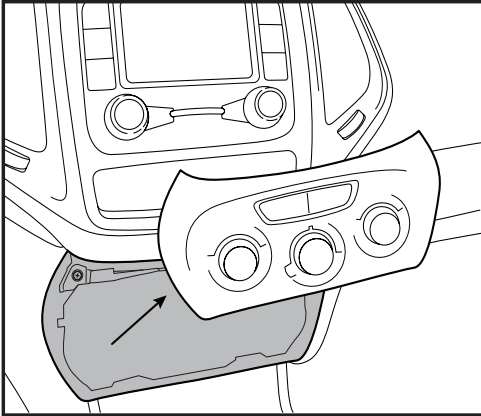

(Figura A)

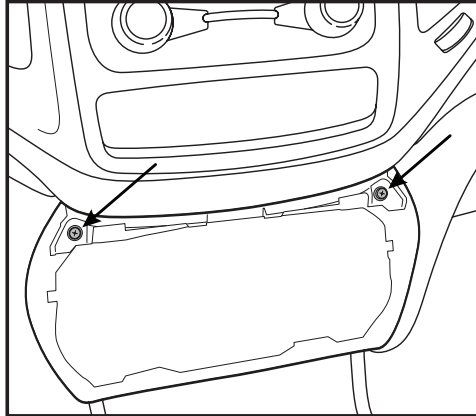

(Figura B)

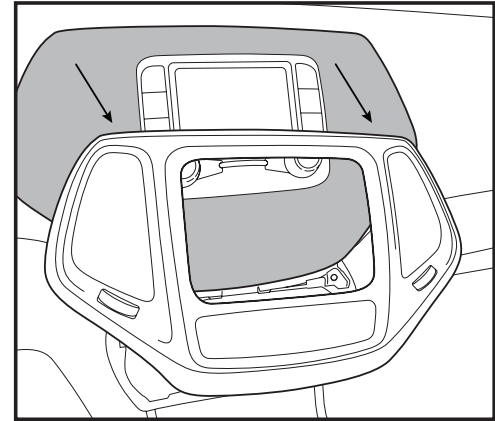

(Figura C)

## Desmontaje Dash Jeep Cherokee Sport 2014 y mas (Continúa)

### Modificación al sub tablero:

1. Quite la cubierta de goma de la parte interior de la cavidad arriba del tablero, luego retire (1) tornillo que queda expuesto.
2. Quite (2) tornillos debajo de la cavidad del radio. (Figura A)
3. Desde el interior de la cavidad del radio, quite los (2) tornillos que sujetan el soporte metálico en el sub tablero y luego deséchelo. (Figura B)
4. Con cuidado, corte el plástico desde la porción inferior trasera de la cavidad del radio, hasta el soporte metálico.. (Figura C)

Continúe con el ensamble del kit

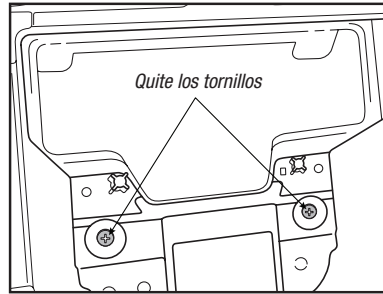

(Figura A)

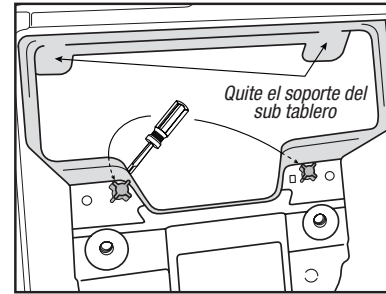

(Figura B)

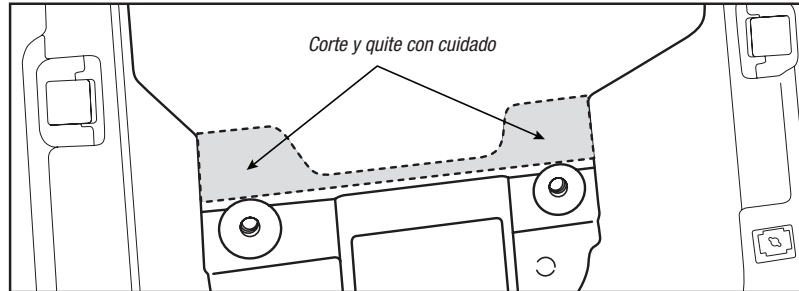

(Figura C)

## Desmontaje Dash

### Ram (sin pantalla táctil de 8.4) 2013 y mas

1. Quite el forro interior de la charola en la parte superior central del tablero y quite los (2) tornillos torx. (Figura A)
2. Suelte a presión y quite el panel del radio. (Figura B)
3. Quite los cuatro tornillos y quite el radio. (Figura C)
4. El soporte trasero de fábrica deberá cortarse o quitarse para hacer espacio para un nuevo radio. La sección inferior puede quitarse con dos cortes en las esquinas inferiores. (Figura D)

*Continúe con el ensamble del kit*

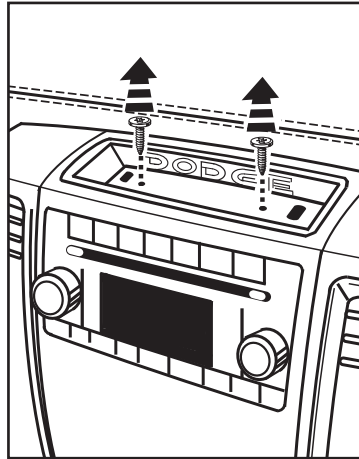

(Figura A)

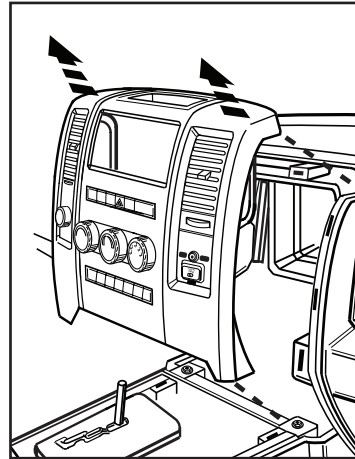

(Figura B)

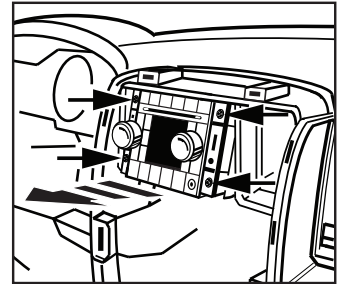

(Figura C)

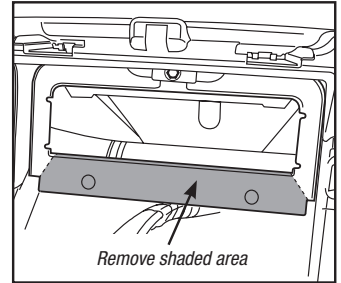

(Figura D)

## Ensamble del kit

### Provisión de radio ISO DIN

**Nota:** Para una correcta orientación, las pestañas localizadoras de la carcasa del radio están más cerca de la parte superior del kit que de la parte inferior. (Figura A)

1. Gire los soportes hacia dentro de la carcasa del radio. (Figura B)
2. Monte la cavidad dentro de los soportes usando los tornillos suministrados #8 x 3/8". (Figura C)
3. Deslice el radio dentro del conjunto del soporte/la cavidad/ el radio y sujételo con los tornillos suministrados con el radio. (Figura D)
4. Localice el arnés de cableado de fábrica y el conector de la antena en el tablero. Metra recomienda el uso de los adaptadores adecuados de acoplamiento de Metra y/o AXXESS.
5. Vuelva a armar el tablero al revés de como lo desarmó..

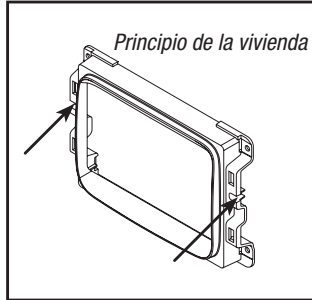

(Figura A)

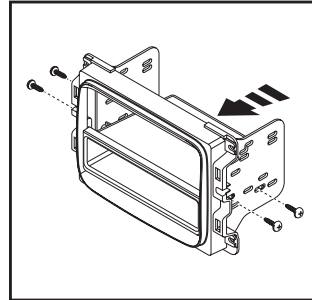

(Figura C)

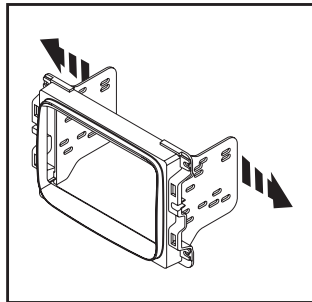

(Figura B)

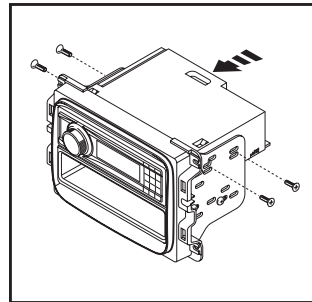

(Figura D)



99-65188

## Notas

---

---

---

---

---

---

---

---

---

---

---

---

---

---

---

---

---

---

---

---

---



Instrucciones de instalación para 99-6518B



REV 11/14/2017 INST99-6518B

## IMPORTANTE

Si tiene dificultades con la instalación de este producto, llame a nuestra línea de soporte técnico al **1-800-253-TECH**. Antes de hacerlo, revise las instrucciones por segunda vez y asegúrese de que la instalación se haya realizado exactamente como se indica en las instrucciones. Por favor tenga el vehículo desarmado y listo para ejecutar los pasos de resolución de problemas antes de llamar.



**EL CONOCIMIENTO ES PODER**  
Mejore sus habilidades de instalación y fabricación inscribiéndose en la escuela de dispositivos electrónicos móviles más reconocida y respetada de nuestra industria. Regístrese en [www.installerinstitute.com](http://www.installerinstitute.com) o llame al 800-354-6782 para obtener más información y avance hacia un futuro mejor.



**Metra recomienda técnicos con certificación del Programa de Certificación en Electrónica Móvil (Mobile Electronics Certification Program, MECP).**