



Audi TT 2008-2015

Visit MetraOnline.com for more detailed information about the product and up-to-date vehicle specific applications

KIT FEATURES

- ISO DDIN radio provision
- Painted scratch resistant matte black

KIT COMPONENTS

- A) Radio trim panel • B) Radio housing • C) (4) Panel clips • D) (8) ISO screws

A

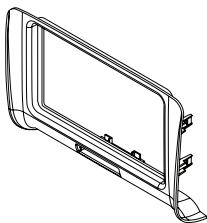

B

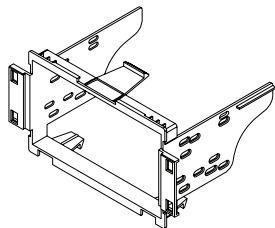

C

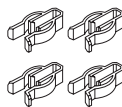

D



TABLE OF CONTENTS

Dash Disassembly	2
Kit Assembly	3

WIRING & ANTENNA CONNECTIONS (sold separately)

Wiring Harness: XSVI-9004-NAV

Antenna Adapter: 40-EU56

TOOLS REQUIRED

- Panel removal tool • Phillips screwdriver
- Socket wrench
- Metra 86-9001 radio removal tools (qty. 2)

Attention! Let the vehicle sit with the key out of the ignition for a few minutes before removing the factory radio. When testing the aftermarket equipment, ensure that all factory equipment is connected before cycling the key to ignition.

DASH DISASSEMBLY

1. Insert (4) of the Metra 86-9001 radio removal tools into the slots on the front of the radio face, and then remove the radio. (Figure A)

Continue to Kit Assembly

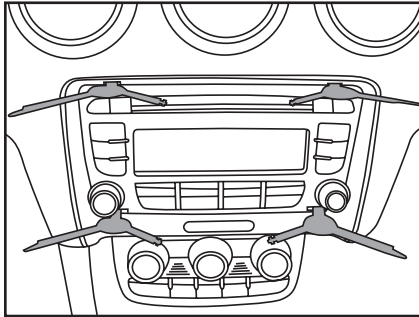

(Figure A)

KIT ASSEMBLY

ISO DDIN radio provision

1. Attach the (4) supplied **panel clips** to the **radio trim panel**. (Figure A)
2. Attach the **radio housing** to the radio using screws supplied with the radio. (Figure B)

Note: The radio mounting screws must be flush in the brackets so the radio assembly will fit into the dash opening. Screws have been provided in the event they were not provided with the aftermarket radio.

3. Locate the factory wiring harness and antenna connector in the dash, and complete all necessary connections to the radio. Metra recommends using the proper mating adapter from Metra and/or AXCESS. Test the radio for proper operation.
4. Slide the radio/radio housing assembly into the dash opening paying close attention to the guides on the **radio housing** and the slots in the dash opening.
5. Snap the **radio trim panel** over the radio and reassemble the dash in reverse order of disassembly.

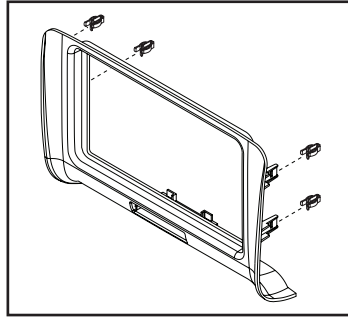

(Figure A)

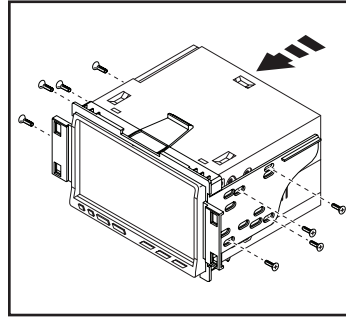

(Figure B)

Continue to Kit Assembly



95-9114B
INSTALLATION INSTRUCTIONS



If you are having difficulties with the installation of this product, contact our Tech Support line either by phone at **386-257-1187**, or email at **techsupport@metra-autosound.com**. Before doing so, look over the instruction booklet a second time and ensure that the installation was performed exactly as the instruction booklet is stated. Have the vehicle apart and ready to perform troubleshooting steps before contacting Metra/Axxess Tech Support.



KNOWLEDGE IS POWER

Enhance your installation and fabrication skills by enrolling in the most recognized and respected mobile electronics school in our industry. Log onto www.installerinstitute.com or call 800-354-6782 for more information and take steps toward a better tomorrow.



Metra recommends MECP certified technicians