

REX
PIPE THREADING MACHINE
N100A

PARTS LIST

As of December 2010

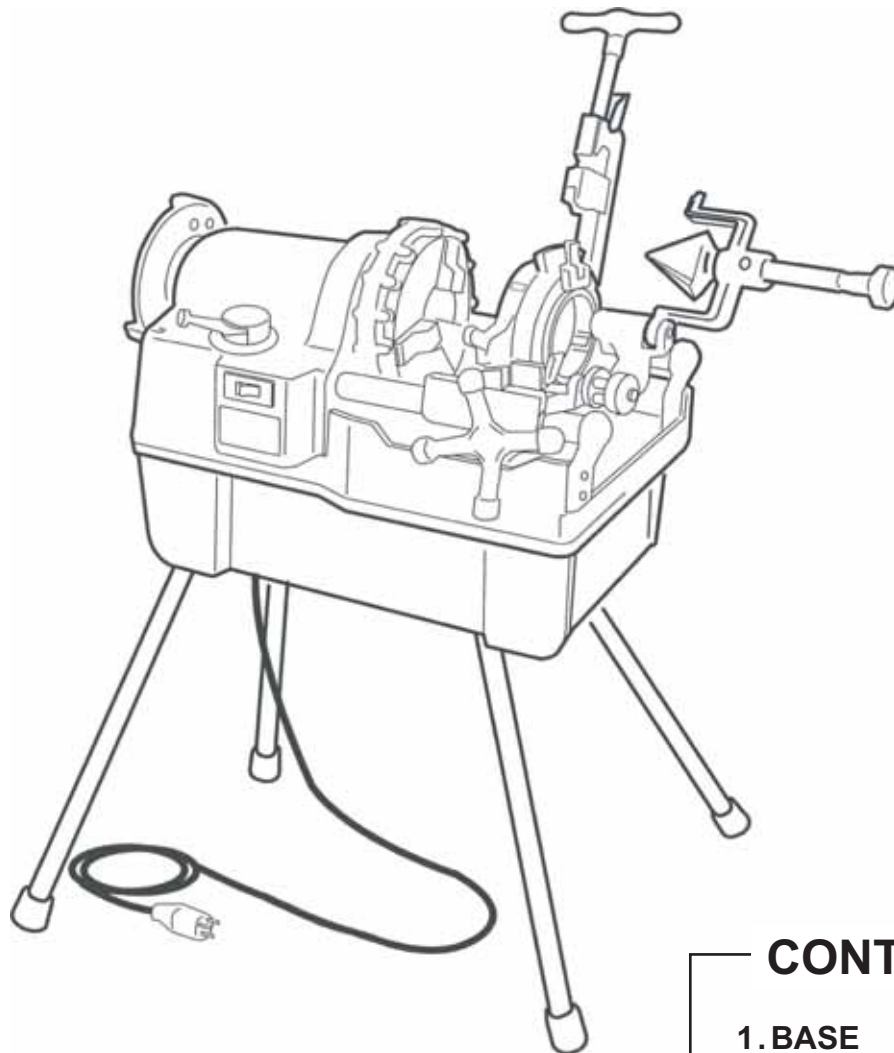

CONTENTS

1. BASE
2. MOTOR
3. MAIN SHAFT
4. MAIN SHAFT 2
5. GEAR CASE
6. CARRIAGE
7. PROFILING
8. CUTTER , REAMER

REX

N100A 1. BASE

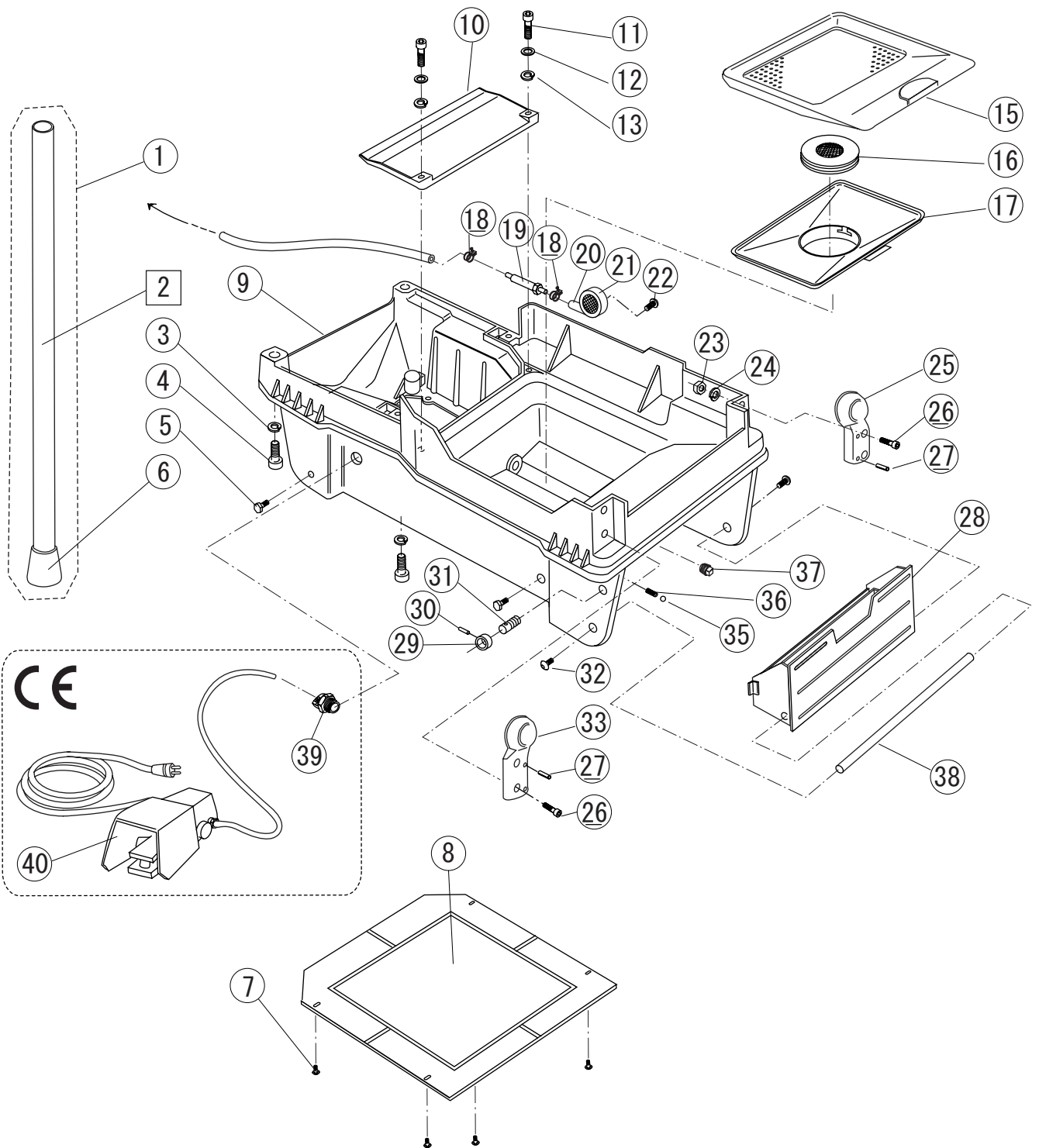

N100A 2. MOTOR

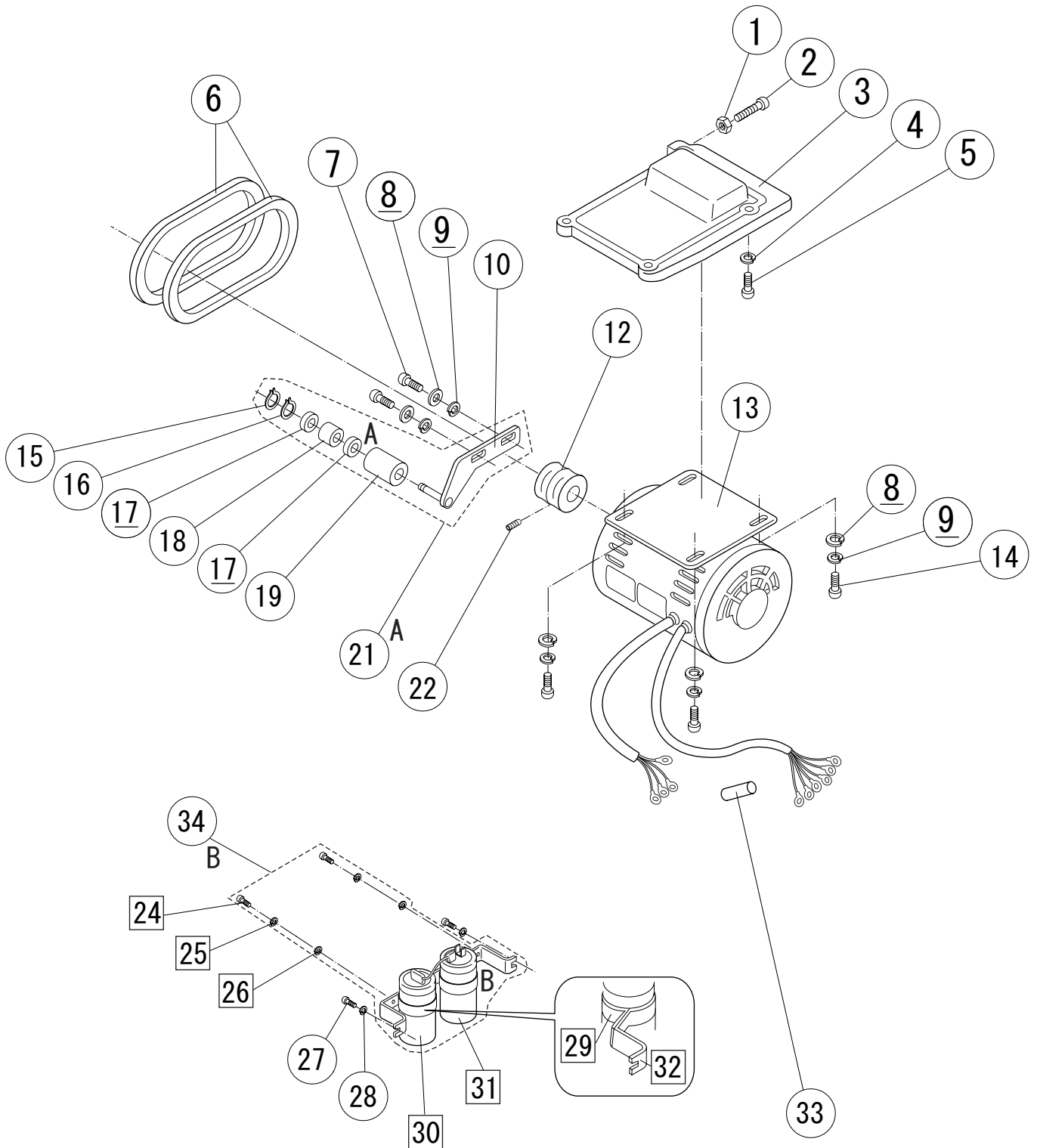

N100A 3. MAIN SHAFT

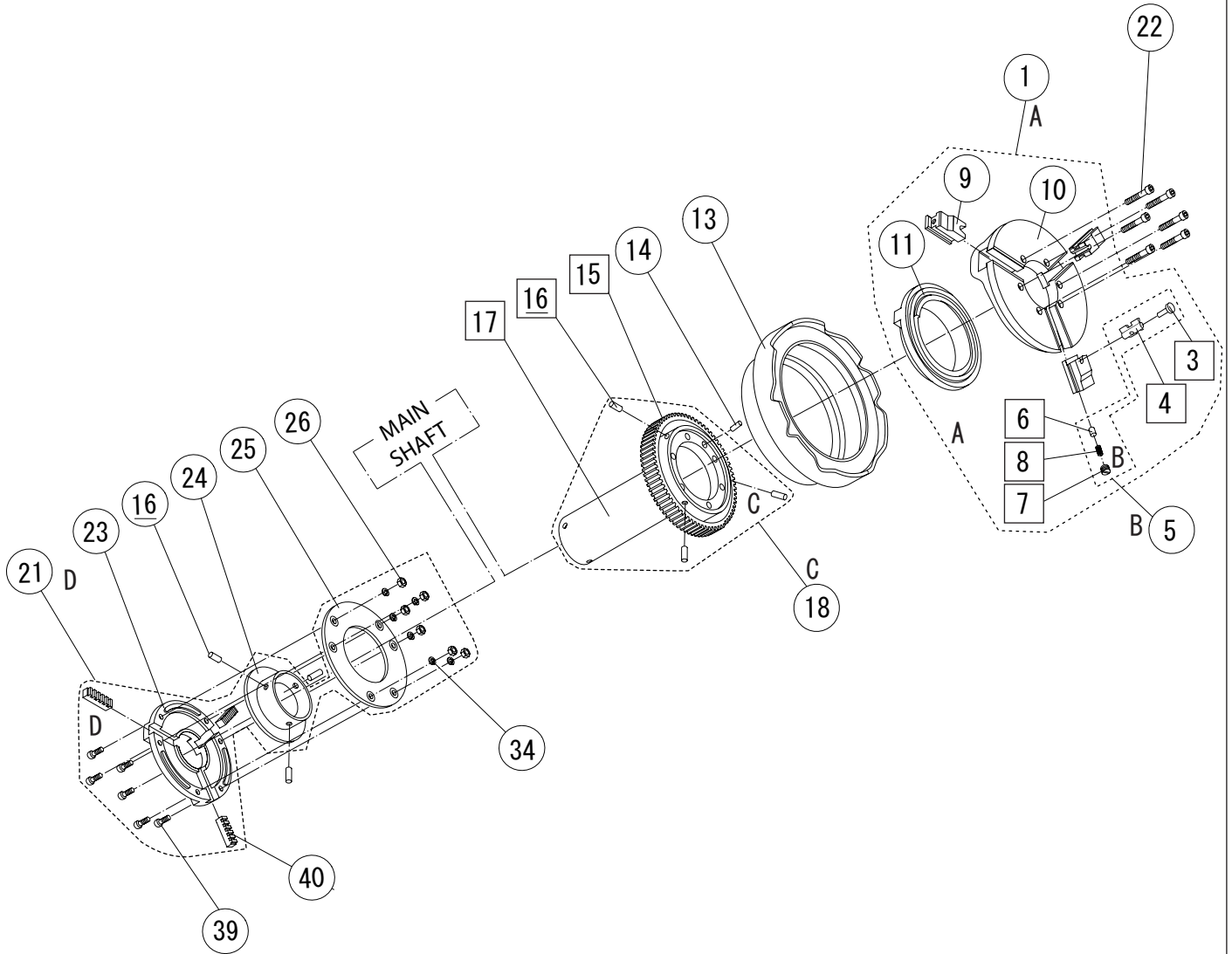

N100A 4. MAIN SHAFT 2

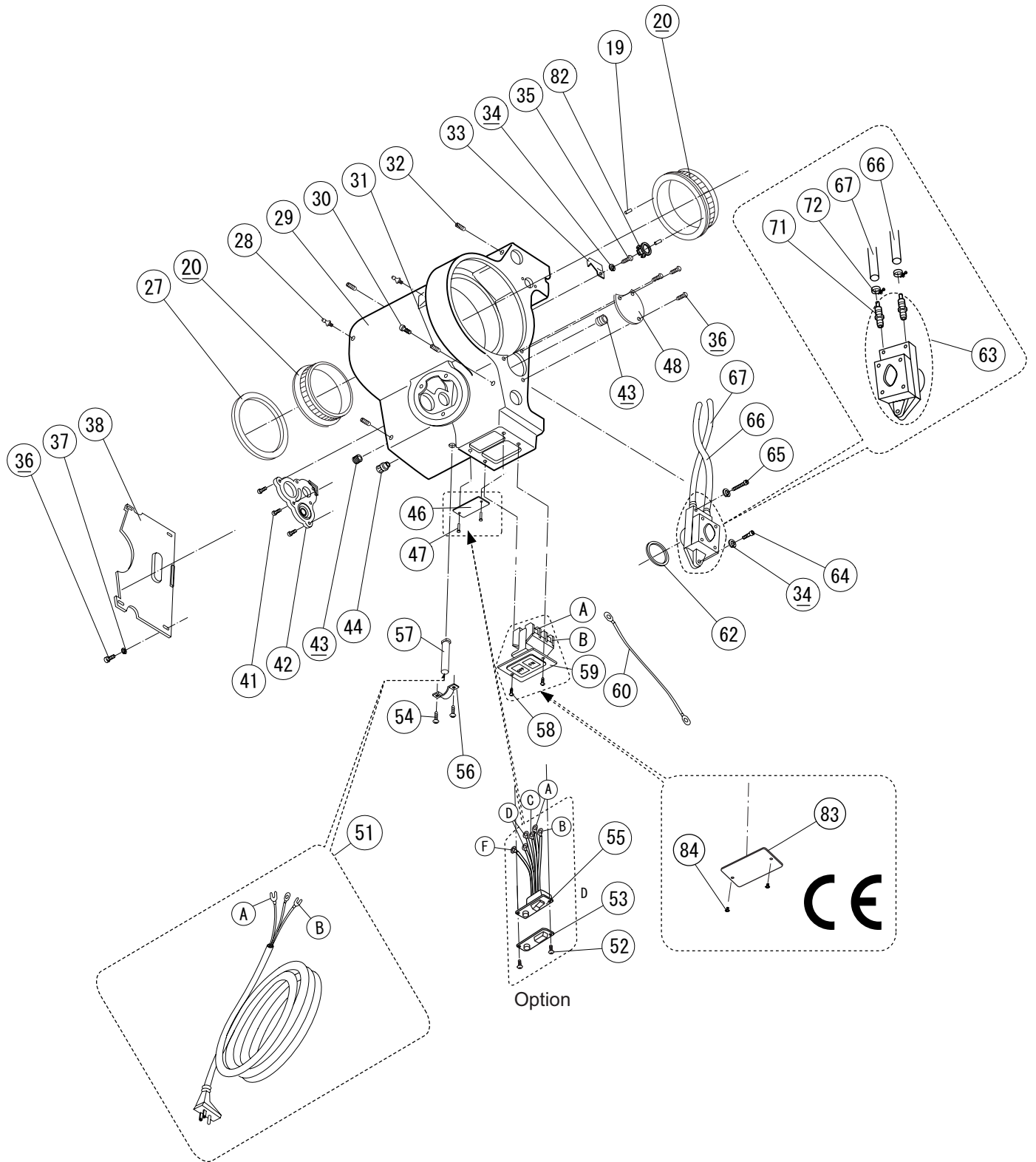

N100A 5. GEAR CASE

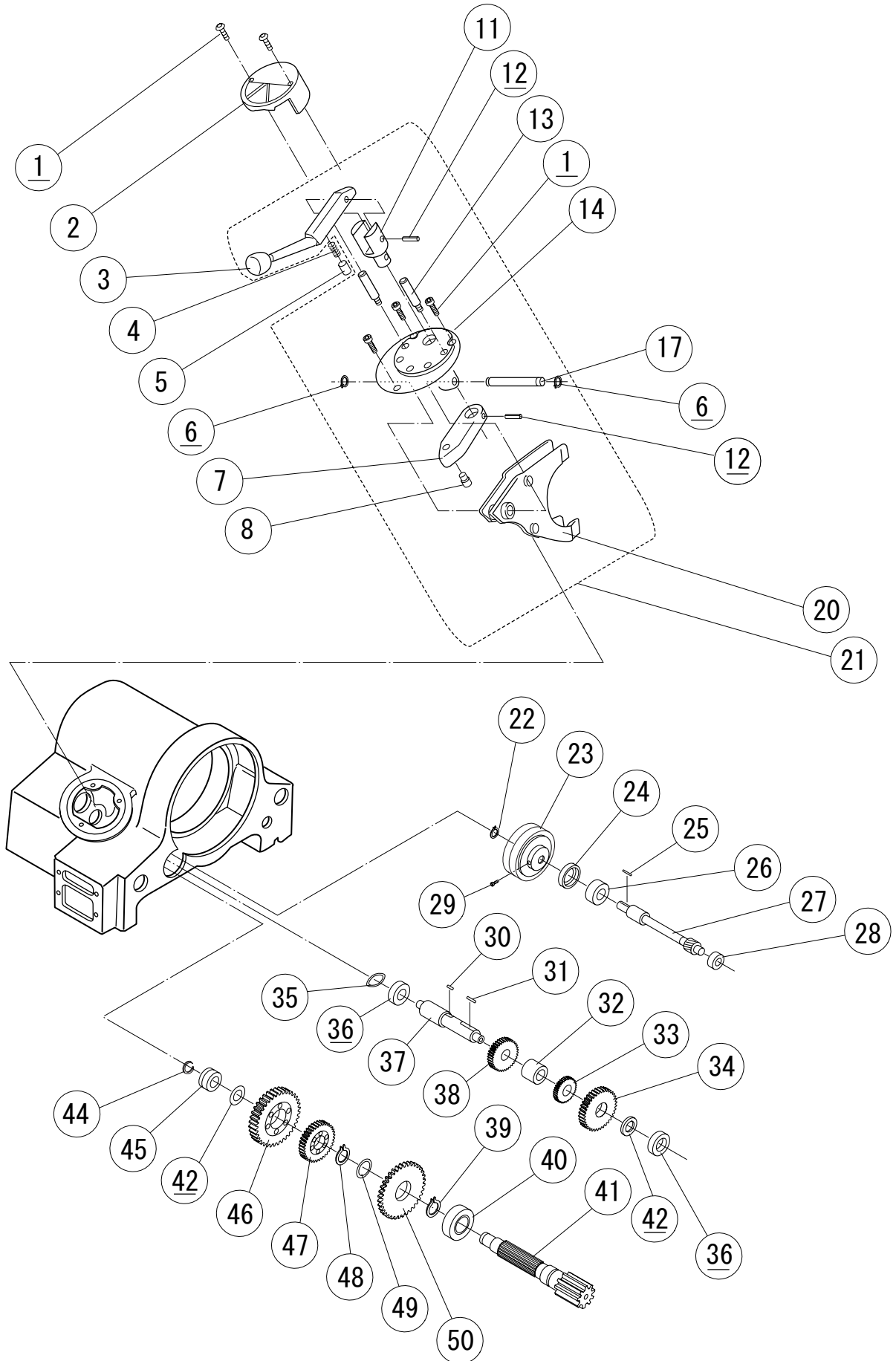

N100A 6. CARRIAGE

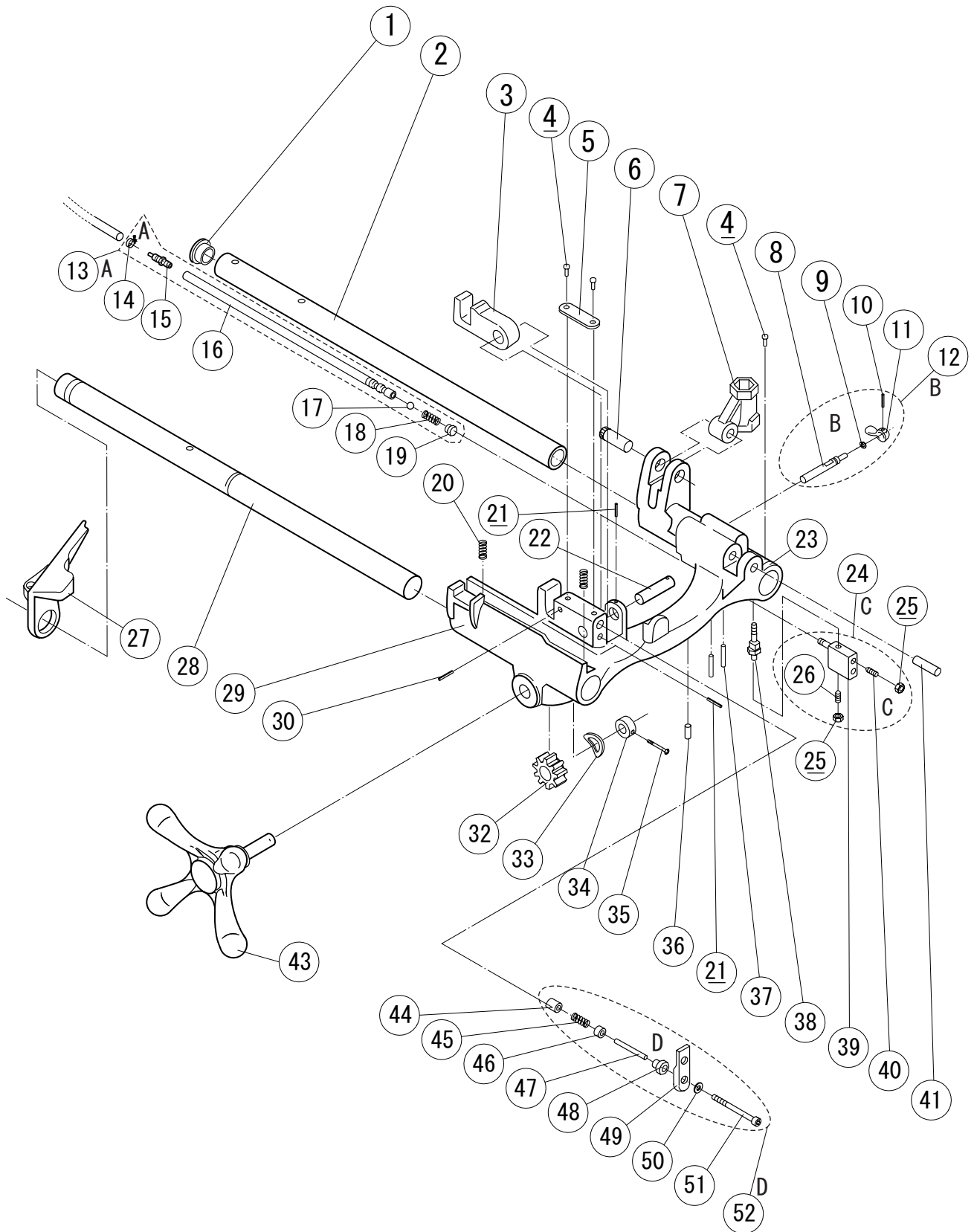

N100A 7. PROFILING

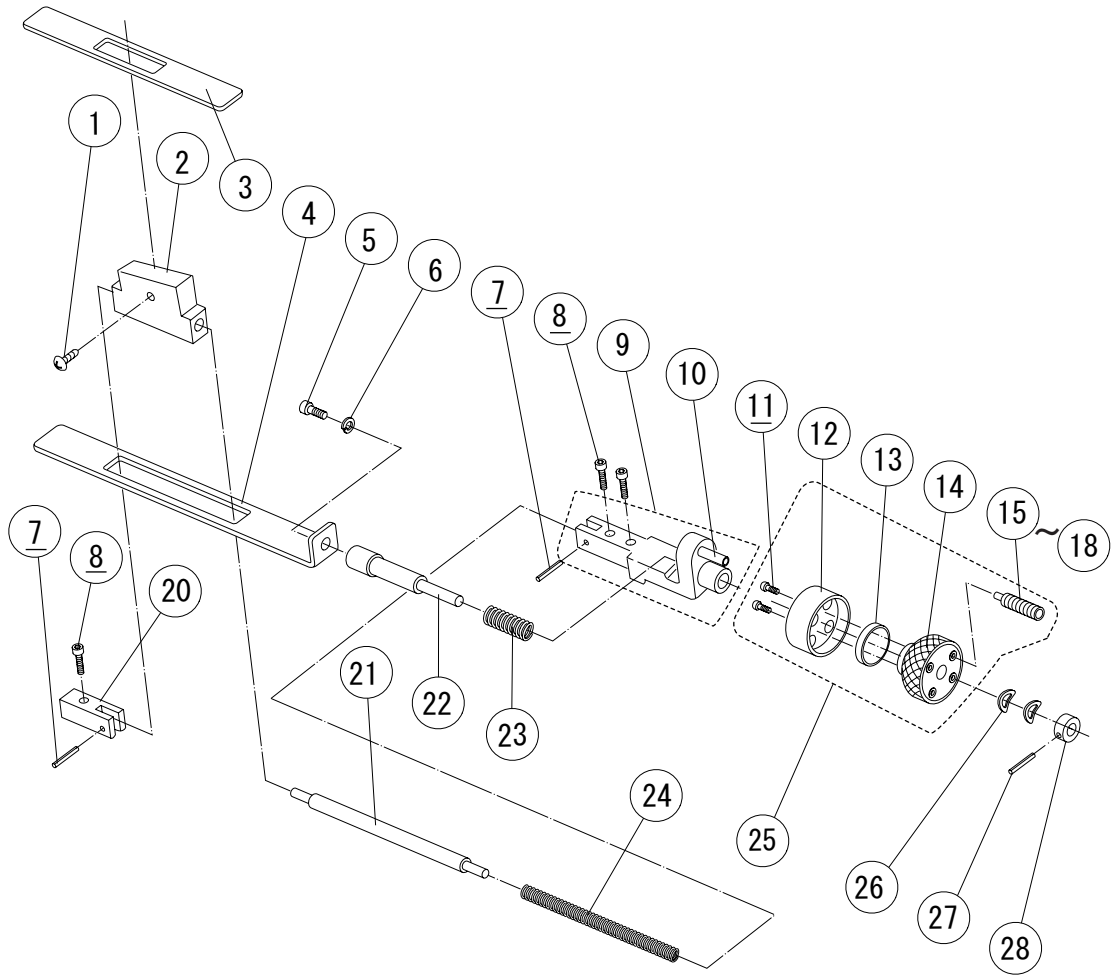

N100A 8. CUTTER, REAMER

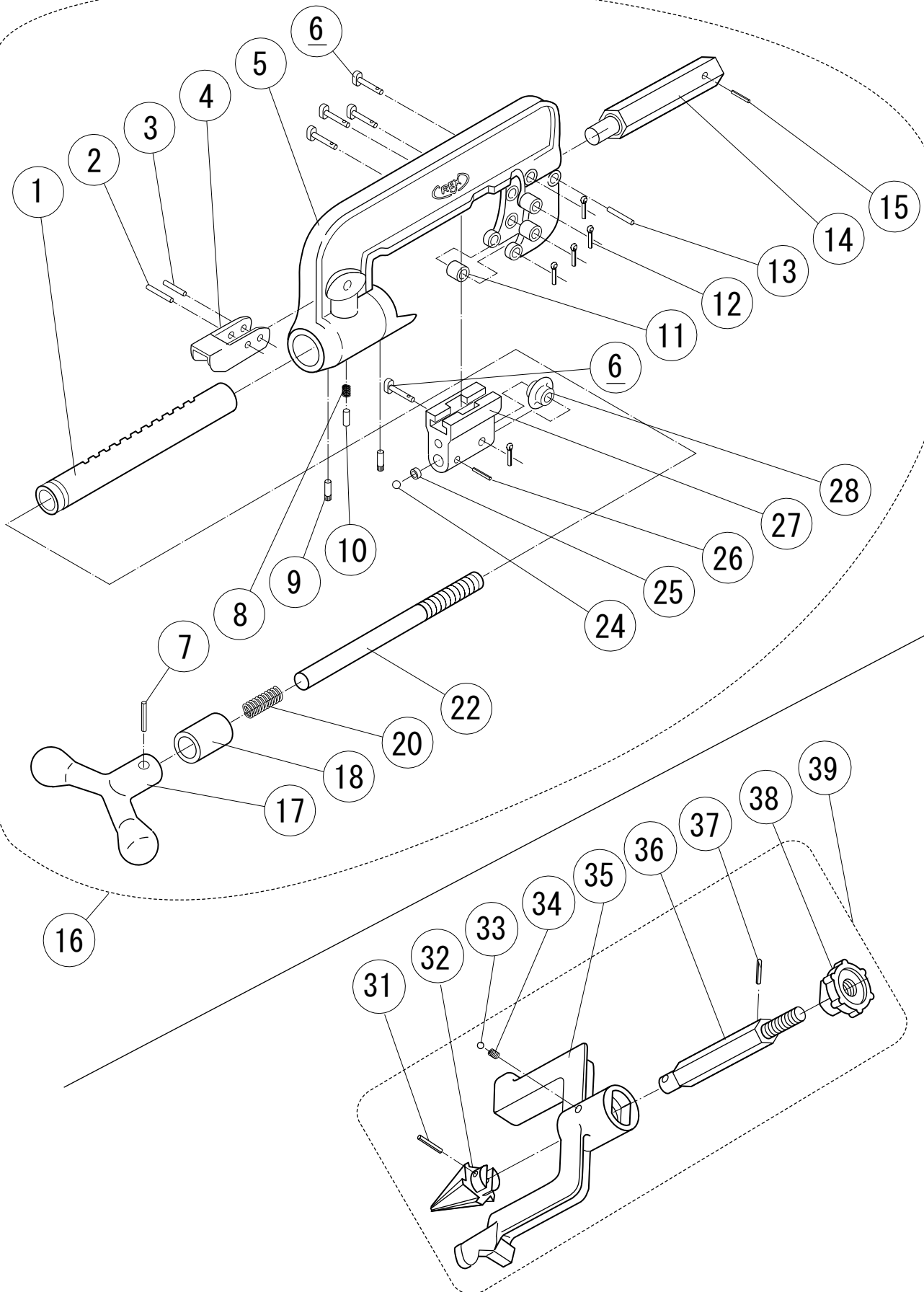

REX

REX

www.rexind.co.jp

REX INDUSTRIES CO., LTD.

Overseas Sales Dept. (Head Office & Factory):

1-9-3, Hishiyahigashi, Higashi Osaka 578-0948, Japan

Tel.: +81 - (0)72 - 961 - 9820 Fax.: +81 - (0)72 - 961 - 9878

URL <http://www.rexind.co.jp>

N100A_exp120517

N100A

2012/5/17

Page No.	Exp. No.	Page Title	CE	Code No.	Parts Name	Spec.	Q'ty	Remarks
1	1	Base		N121	Pipe Stand with Leg Cap		4	price per pce, No.2,6 as a set
1	3	Base		W101	Spring Washer	Φ10	4	
1	4	Base		WG100	Hex Socket Head Cap Screw	M10x40	4	
1	5	Base		WG040	Hexagonal Head Bolt	M10x30	4	
1	6	Base		N125	Leg Cap		4	
1	7	Base		W251	Pan Head Machine Screw	M5x8	4	
1	8	Base		J008	Bottom Cover		1	
1	9	Base	No	J001	Base		1	
1	9	Base	Yes	J060	Base CE		1	
1	10	Base		J006	Base Cover		1	
1	11	Base		W255	Pan Head Machine Screw	M5x25	2	
1	12	Base		WG05	Spring Washer	Φ5	2	
1	13	Base		W152	Flat Washer	Φ5	2	
1	15	Base		J007	Scrap Receiver		1	
1	16	Base		J005	Upper Cover Strainer Cap		1	
1	17	Base		J004	Tank Upper Cover		1	
1	18	Base		ZJ50	Hose Band	10mm	2	
1	19	Base		J015	Nipple		1	
1	20	Base		N049	Oil Intake Line Suction Tube(A)	55mm	1	
1	21	Base		N048	Strainer		1	
1	22	Base		WA55	Pan Head Tapping Screw	M5x8	1	
1	23	Base		WC080	Nut	M8	4	
1	24	Base		WG080	Spring Washer	Φ8	4	
1	25	Base		J002	Support (Right)		1	
1	26	Base		W083	Hex Socket Head Cap Screw	M8x25	4	
1	27	Base		WL650	Roll Pin	Φ6x30	4	
1	28	Base		J010	Built-In Tool Box		1	
1	29	Base		J013	Stopper Pin B		1	
1	30	Base		WL360	Roll Pin	Φ3x18	1	
1	31	Base		J012	Stopper Pin A		1	
1	32	Base		W585	Truss Head machine Screw	M8x20	2	
1	33	Base		J003	Support (Leftt)		1	
1	35	Base		WQ05	Steel Ball	Φ5	1	
1	36	Base		7752	Spring		1	
1	37	Base		WA460	Drain Plug	PT1/2	1	
1	38	Base		J011	Tool Box Shaft		1	
1	39	Base	Yes	J059	Cable Guide		1	
1	40	Base	Yes	FSW1	Foot Switch for CE		1	

Page No.	Exp. No.	Page Title	CE	Code No.	Parts Name	Spec.	Q'ty	Remarks
2	1	Motor		W008	Nut	M8	1	
2	2	Motor		W08C	Hex Socket Head Cap Screw	M8x70	1	
2	3	Motor		J020	Motor Fix Plate		1	
2	4	Motor		WG100	Spring Washer	Φ10	4	
2	5	Motor		W002	Hex Socket Head Cap Screw	M10x25	4	
2	6	Motor		Z824	V-Belt	A-24	2	
2	6	Motor	No	Z823	V-Belt Short	A-23	2	set with 4931/4063 (HK ver. Only)
2	7	Motor		W083	Hex Socket Head Cap Screw	M8x20	2	
2	8	Motor		WG080	Spring Washer	Φ8	6	
2	9	Motor		WI84	Flat Washer	Φ8	6	
2	10	Motor		J019	Tension Pulley Adjustment Mounting Se		1set	
2	12	Motor	No	4931	Motor V-Pulley 60Hz/50Hz	φ60.9	1	set with 4926 (HK ver. 4063)
2	12	Motor		T066	Motor V-Pulley 50Hz	φ68.5	1	set with 4063
2	13	Motor		J029T	Motor	1.0KW110-230V	1	
2	13	Motor	No	J028T	Motor	1.0KW100-110V	1	
2	13	Motor	No	J030T	Motor	1.0KW120V	1	
2	14	Motor		WI81	Hexagonal Head Bolt	M8x20	4	
2	15	Motor		WW12	Snap Ring (External)	Φ12	1	
2	16	Motor		WWA2	Snap Ring (Internal)	Φ28	1	
2	17	Motor		J300	Bearing	#6001ZZ	2	
2	18	Motor		J026	Tension Pulley Bearing Collar		1	
2	19	Motor		J025	Tension Pulley		1	
2	21	Motor		0JHP1S	Tension Pulley assembly		1set	A: No.10,15-19 as a se
2	22	Motor		W78A	Hex-Socket Set Screw	M8x8	1	
2	27	Motor		W251	Pan Head Machine Screw	M5x8	2	
2	28	Motor		W152	Flat Washer	Φ5	2	
2	34	Motor		49CST	Condenser Set		1 set	No.24-26,29-32 as a se

Page No.	Exp. No.	Page Title	CE	Code No.	Parts Name	Spec.	Q'ty	Remarks
3	1	Main Shaft	No	J051	Chuck Complete Set	RT type	1set	No.5,9,10,11 as a set
3	1	Main Shaft	Yes	J050	Chuck Complete Set CE, TWN	RS type	1set	No.5,9,10,11 as a set
3	5	Main Shaft	No	A0RT	Chuck Jaw Insert Set	RT type	1set	3pcs each of No. 3,4,6-8 as a se
3	5	Main Shaft	Yes	A0RS	Chuck Jaw Insert Set CE, TWN	RS type	1set	3pcs each of No. 3,4,6-8 as a se
3	10	Main Shaft		JH00	Chuck Body		1	
3	11	Main Shaft		JS00	Chuck Scroll		1	
3	12	Main Shaft	No	J1CJS	Chuck jaw Set	RT type	1set	3pcs each incl. No. 5 (A0RT) as a set
3	12	Main Shaft	Yes	J0CJ	Chuck jaw Set CE, TWN	RS type	1set	3pcs each incl. No. 5 (A0RS) as a set
3	13	Main Shaft		J703	Hand Wheel		1	
3	14	Main Shaft		WN08	Straight Pin		1	
3	16	Main Shaft		WL63	Roll Pin	Φ6x18	6	=>3 pins are for gear and shaft connection
3	18	Main Shaft		02JJ	Main Shaft with Gear		1set	No. 15-17 as a set
3	21	Main Shaft	No	A006	Rear Chuck Complete Set		1set	No. 21, 23-26, 34, 39, 40 as a set
3	21	Main Shaft	Yes	J058	Rear Chuck Complete Set CE		1set	No. 21, 23-26, 34, 39, 40 as a set
3	22	Main Shaft		W07B	Hex Socket Head Cap Screw	M7x54	6	
3	23	Main Shaft	No	J0S1	Rear Chuck Receptacle		1	
3	23	Main Shaft	Yes	-	Rear Chuck Receptacle CE old type		1	discontinued
3	23	Main Shaft	Yes	JCS1	Rear Chuck Receptacle CE new type		1	
3	24	Main Shaft	No	J0S3	Rear Scroll		1	
3	24	Main Shaft	Yes	-	Rear Scroll CE old type		1	discontinued
3	24	Main Shaft	Yes	JCS3	Rear Scroll CE new type		1	
3	25	Main Shaft	No	J0S2	Rear Chuck Cover		1	
3	25	Main Shaft	Yes	-	Rear Chuck Cover CE old type		1	discontinued
3	25	Main Shaft	Yes	JCS2	Rear Chuck Cover CE new type		1	
3	26	Main Shaft		WC06	Nut	M6	6	
3	34	Main Shaft		WG06	Spring Washer	Φ6	9	
3	39	Main Shaft		W062	Hex Socket Head Cap Screw	M6x16	6	
3	40	Main Shaft	No	A0SS	Rear Chuck Jaw		3	
3	40	Main Shaft	Yes	-	Rear Chuck Jaw CE old type		3	discontinued
3	40	Main Shaft	Yes	JCSS	Rear Chuck Jaw CE new type		3	

Page No.	Exp. No.	Page Title	CE	Code No.	Parts Name	Spec.	Q'ty	Remarks
4	19	Main Shaft2		WL41	Roll Pin	Φ4x10	4	
4	20	Main Shaft2		J039	Rear Main Shaft Bearing		2	
4	27	Main Shaft2		A008	Thrust Ring		1	
4	28	Main Shaft2		J009	Grease Nipple	M6	2	
4	29	Main Shaft2	No	J035	Head Stock		1	
4	29	Main Shaft2	Yes	J061	Head Stock CE		1	
4	30	Main Shaft2		W080	Hex Socket Head Cap Screw	M8x15	1	
4	31	Main Shaft2		W78D	Hex-Socket Set Screw	M8x12M cone point	1	
4	32	Main Shaft2		W686	Hex-Socket Set Screw	M8x22M cone point	3	
4	33	Main Shaft2		4086	Hose fixing plate		1	
4	34	Main Shaft2		WG06	Spring Washer	Φ6	9	
4	35	Main Shaft2		W261	Pan Head Machine Screw	M6x10	1	
4	36	Main Shaft2		W252	Pan Head Machine Screw	M5x10	7	
4	37	Main Shaft2		W152	Flat Washer	Φ5x12x0.8	4	
4	38	Main Shaft2		J041	Rear Cover		1	
4	41	Main Shaft2		W055	Hex Socket Head Cap Screw	M5x18	6	
4	42	Main Shaft2		J040	Gear Case Cover		1	
4	43	Main Shaft2		WA44	Hex-Socket Pipe Plug	PT1/8	2	
4	44	Main Shaft2		J320**	Nut	M4	1	
4	46	Main Shaft2		J045	Name Plate - N100A		1	not for sale
4	47	Main Shaft2		WN34	Rivet	4x5	2	
4	48	Main Shaft2		J042	Window Cap		1	
4	50	Main Shaft2		4081	Power Plug Adapter	100-110V	1	for 04CT1S
4	51	Main Shaft2	No	N122	Cabtyre Cord	220V	1	
4	51	Main Shaft2	No	N132	Cabtyre Cord with SA plug	220V 3pins	1	
4	51	Main Shaft2	No	4082	Cabtyre Cord	120V		
4	51	Main Shaft2	No	04CT1S	Cabtyre Cord	100-110V	1	
4	52	Main Shaft2		W240	Pan Head Machine Screw	M4x5	2	Option
4	53	Main Shaft2		4010	Voltage Shift Switch Cover		1	Option
4	54	Main Shaft2		W242	Pan Head Machine Screw	M4x10	4	
4	55	Main Shaft2		0JKS1S	Voltage Selector	110/220V	1	Option
4	56	Main Shaft2		7098	Binder		1	
4	57	Main Shaft2		7021	Cord Bush		1	
4	58	Main Shaft2	No	W4A4	Oval Head Machine Screw	M4x15	3	
4	59	Main Shaft2	No	N008	Switch		1	
4	60	Main Shaft2	No	#0035	Earth		1	
4	61	Main Shaft2	No	N041	Switch Packing		1	
4	62	Main Shaft2		J047	Gear Pump Gasket		1	
4	63	Main Shaft2		4025	Gear Pump with Joints	incl. 2 of N5328	1	incl. No. 71
4	64	Main Shaft2		W063	Hex Socket Head Cap Screw	M6x20	1	
4	65	Main Shaft2		W065	Hex Socket Head Cap Screw	M6x30	1	
4	66	Main Shaft2		0410	Oil Feed Line Tube	530mm	1	
4	67	Main Shaft2		0410	Oil Intake Line Suction Tube	700mm	1	
4	71	Main Shaft2		1035	Oil Joint		2	
4	72	Main Shaft2		ZJ50	Hose Band	10mm	2	
4	82	Main Shaft2		4040	Hose Guide		1	
4	83	Main Shaft2	Yes	J340	Name Plate CE		1	not for sale
4	83	Main Shaft2	Yes	J348	Name Plate CE for Voltage Shift Switch		1	Option, not for sale
4	84	Main Shaft2	Yes	WN34	Rivet		8	
4	85	Main Shaft2	Yes	L099	Warning Plate CE		1	

Page No.	Exp. No.	Page Title	CE	Code No.	Parts Name	Spec.	Q'ty	Remarks
5	1	Gear Case		WA27	Hex Socket Head Cap Screw	M6x16	5	
5	2	Gear Case		J201	Speed Change Cap		1	
5	3	Gear Case		J202	Speed Change Lever		1	
5	4	Gear Case		J216	Spring		1	
5	5	Gear Case		J203	Notch Pin		1	
5	6	Gear Case		WW10	Split Pin	#2.5x14	1	
5	7	Gear Case		J205	Fork Lever		1	
5	8	Gear Case		J208	Fork Lever Pin		1	
5	11	Gear Case		J204	Speed Change Shaft		1	
5	12	Gear Case		WL66	Roll Pin	Φ6x30	2	
5	13	Gear Case		J215	Stud Bolt		2	
5	14	Gear Case		J220	Speed Change Cover Set		1set	A:No.15-16 as a set
5	17	Gear Case		J207	Guide Pin		1	
5	20	Gear Case		J221	Gear Shift Fork Set		1set	No.9-10,18-19 as a set
5	21	Gear Case		OJHE1S	Speed Change Complete Set		1set	C:No.3,6-8,11-14,17,20 as a set
5	22	Gear Case		WW18	Snap Ring (External)	Φ18	1	
5	23	Gear Case	No	4926	Mission V-Pulley 60Hz/50Hz	φ101.6	1	set with 4931
5	23	Gear Case		4063	Mission V-Pulley 50Hz	φ88.9	1	set with T066 (HK ver. 4931)
5	24	Gear Case		J310	Oil Seal	Φ25x45x10	1	
5	25	Gear Case		WR550	Key	5x5x21	1	
5	26	Gear Case		A192	Bearing	#6205ZZ	1	
5	27	Gear Case		J180	A Shaft		1	
5	28	Gear Case		H272	Bearing	#6202ZZ	1	
5	29	Gear Case		W78C	Hex-Socket Set Screw	M8x14M cup point	1	
5	30	Gear Case		WS830	Key	C型:8x7x25	1	
5	31	Gear Case		WR820	Key	8x7x11	1	
5	32	Gear Case		J192	B Shaft Collar		1	
5	33	Gear Case		J183	B Shaft Gear B		1	
5	34	Gear Case		J182	B Shaft Gear A		1	
5	35	Gear Case		WH30	Wave Washer	BWW6203	1	
5	36	Gear Case		A191	Bearing	#6004ZZ	2	
5	37	Gear Case		J181	B Shaft		1	
5	38	Gear Case		J184	B Shaft Gear C		1	
5	39	Gear Case		W35	Snap Ring (External)	Φ35	1	
5	40	Gear Case		J302	Bearing	#6007ZZ	1	
5	41	Gear Case		J185	C Shaft		1	
5	42	Gear Case		J193	C Shaft Collar(Large)		2	
5	44	Gear Case		WW20	Snap Ring (External)	Φ20	1	
5	45	Gear Case		J301	Bearing	#6204ZZNR	1	
5	46	Gear Case		J188	C Shaft Gear C		1	
5	47	Gear Case		J187	C Shaft Gear B		1	
5	48	Gear Case		WW30	Snap Ring (External)	Φ30	1	
5	49	Gear Case		J194	C Shaft Collar (Small)		1	
5	50	Gear Case		J186	C Shaft Gear A		1	

Page No.	Exp. No.	Page Title	CE	Code No.	Parts Name	Spec.	Q'ty	Remarks
6	1	Carriage		J148	Carriage Support Bar B Cap		1	
6	2	Carriage		J112	Carriage Support Bar B		1	
6	3	Carriage		J113	Die Head Holder		1	
6	4	Carriage		WN34	Rivet	4x5	4	
6	5	Carriage		J145	Open Plate		1	
6	6	Carriage		J166	Cutter Arm Stop Pin		1	
6	7	Carriage		J162	Cutter Arm		1	
6	8	Carriage		J143	Oil Flow Selector Shaft		1	
6	9	Carriage		Z511	O-Ring	Φ11	1	
6	10	Carriage		WL360	Roll Pin	Φ3x18	1	
6	11	Carriage		J144	Oil Flow Selector Lever		1	
6	14	Carriage		ZJ50	Hose Band	10mm	1	order with No.15
6	15	Carriage		1035	Oil Joint		1	order with No.14
6	16	Carriage		J140	Oil Pipe (Large)		1	
6	17	Carriage		G861	Steel Ball	8	1	
6	18	Carriage		T050	Spring		1	
6	19	Carriage		W702	Hex-Socket Set Screw	M10x10 Cup Point	1	
6	20	Carriage		E140	Spring		2	
6	21	Carriage		WL52	Roll Pin	5x12	2	
6	22	Carriage		J114	Die Head Holder Shaft		1	
6	23	Carriage		J155	Oil Flow Selector Plate		1	order with No. 36
6	25	Carriage		WD06	Nut	M6	2	
6	26	Carriage		W667	Hex-Socket Set Screw	M6x25 Cone Point	1	
6	27	Carriage		J702	Security Collar		1	
6	28	Carriage		J111	Carriage Support Bar A		1	
6	29	Carriage		J110	Carriage		1	order with G861 (No. 36)
6	30	Carriage		1036	Oil Joint Pin		1	
6	32	Carriage		A515	Carriage Feed Gear		1	
6	33	Carriage		WH20	Wave Washer	20.7x29.1x3	1	
6	34	Carriage		9018	Feed Gear Stop Ring		1	
6	35	Carriage		W256	Pan Head Machine Screw	M5x30	1	
6	36	Carriage		G861	Ball Plunger	Φ10	2	
6	37	Carriage		WL59	Roll Pin	Φ5x45	2	
6	38	Carriage		J142	Oil Pipe (Small)		1	
6	39	Carriage		J141	Oil Pipe Connector		1	
6	40	Carriage		W6670	Hex-Socket Set Screw	M6x25 Cone Point	1	
6	41	Carriage		1096	Reamer Arm Stop Pin		1	
6	43	Carriage		A517	Carriage Handle Set		1	
6	44	Carriage		A109	Die Head Stop Pin		1	
6	45	Carriage		A115	Spring		1	
6	46	Carriage		J147	Knob Pin Bush S		1	
6	47	Carriage		J139	Knob Pin Bush		1	
6	48	Carriage		A110	Die Head Stop Pin Cover		1	
6	49	Carriage		J136	Die Head Lock Knob		1	
6	50	Carriage		J137	Hemi-Spherical Washer		1	
6	51	Carriage		W05B	Hex Socket Head Cap Screw	M5x60	1	
6	52	Carriage		03JP	Die Head Stop Pin Cover Set		1set	D: No.44-51 as a set

Page No.	Exp. No.	Page Title	CE	Code No.	Parts Name	Spec.	Q'ty	Remarks
7	1	Profiling		W2500	Pan Head Machine Screw	M5x6	1	
7	2	Profiling		J115	Profiling Board	BSP T/NPT	1	
7	2	Profiling		J109	Profiling Board	NPSM	1	
7	3	Profiling		J122	Profiling Cover B		1	
7	4	Profiling		J121	Profiling Cover A		1	
7	5	Profiling		W08A0	Hex Socket Head Cap Screw	M8x10	1	
7	6	Profiling		W1820	Flat Washer	Φ8	1	
7	7	Profiling		WLA40	Roll Pin	Φ3x18	2	
7	8	Profiling		W062	Hex Socket Head Cap Screw	M6x16	3	
7	9	Profiling		J117	Spring Support Shaft Holder B		1	incl. No. 10 (J120)
7	10	Profiling		J120	Size Stopper Pin		1	
7	11	Profiling		W2310	Pan Head Machine Screw	M3x5	2	
7	12	Profiling		J135	Size Plate Cover		1	
7	13	Profiling		J151	Spring		1	
7	14	Profiling		J124	Size Plate		1	
7	15	Profiling		J235	Size Stopper Screw	4" BSPT	1	
7	15	Profiling		J239	Size Stopper Screw	4" NPT/NPSM	1	
7	16	Profiling		J236	Size Stopper Screw	3 1/2" BSPT	1	
7	16	Profiling		J231	Size Stopper Screw	3 1/2" NPT/NPSM	1	
7	17	Profiling		J237	Size Stopper Screw	3" BSPT	1	
7	17	Profiling		J241	Size Stopper Screw	3" NPT/NPSM	1	
7	18	Profiling		J238	Size Stopper Screw	2 1/2" BSPT	1	
7	18	Profiling		J242	Size Stopper Screw	2 1/2" NPT/NPSM	1	
7	20	Profiling		J116	Spring Support Shaft Holder A		1	
7	21	Profiling		J123	Spring Support Shaft		1	
7	22	Profiling		J119	Size Adjustment Shaft		1	
7	23	Profiling		J150	Spring		1	
7	24	Profiling		J149	Spring		1	
7	25	Profiling		0JNA2S	Profiling Board Cap		1set	No. 11-18 as a set
7	25	Profiling		0JSA3S	Profiling Board Cap NPT/NPSM	NPT/NPSM	1set	No. 11-18 as a set
7	26	Profiling		WH120	Wave Washer	Φ12	2	
7	27	Profiling		WL460	Oil Joint Pin	Φ4x20	1	
7	28	Profiling		J126	Stop Collar		1	

Page No.	Exp. No.	Page Title	CE	Code No.	Parts Name	Spec.	Q'ty	Remarks
8	1	Cutter, Reamer		J168	Feed Holder		1	for QA type (standard)
8	2	Cutter, Reamer		WL87	Roll Pin	Φ8x45	1	for QA type (standard)
8	3	Cutter, Reamer		WL69	Roll Pin	Φ6x45	1	for QA type (standard)
8	4	Cutter, Reamer		J171	Open Lever		1	for QA type (standard)
8	5	Cutter, Reamer		J160	Cutter Frame		1	for QA type (standard)
8	6	Cutter, Reamer		5079	Cutter Pin (Long)		5	
8	7	Cutter, Reamer		WL68	Roll Pin	Φ6x35	1	
8	8	Cutter, Reamer		J174	Spring		1	for QA type (standard)
8	9	Cutter, Reamer		J175	Pin		1	for QA type (standard)
8	10	Cutter, Reamer		J170	Adjustment Pin		1	
8	11	Cutter, Reamer		5074	Cutter Roller		4	
8	12	Cutter, Reamer		WN12	Split Pin	#2.5x14	5	
8	13	Cutter, Reamer		9027	Cutter Guide Pin		1	
8	14	Cutter, Reamer		J165	Cutter Arm Shaft		1	
8	15	Cutter, Reamer		WL57	Roll Pin	Φ5x35	1	
8	16	Cutter, Reamer		0JCU1S	Cutter Complete Set Quick type		1 set	QA type (standard)
8	17	Cutter, Reamer		E205	Cutter Handle		1	for QA type (standard)
8	18	Cutter, Reamer		J169	Stop Cap		1	for QA type (standard)
8	19	Cutter, Reamer		J168	Feed Holder		1	for QA type (standard)
8	20	Cutter, Reamer		J173	Spring		1	
8	22	Cutter, Reamer		J163	Feed Screw		1	for QA type (standard)
8	24	Cutter, Reamer		WQ10	Steel Ball	Φ10	1	
8	25	Cutter, Reamer		J164	Thrust Roller		1	
8	26	Cutter, Reamer		WL56	Roll Pin		1	
8	27	Cutter, Reamer		J161	Cutter Guide		1	
8	28	Cutter, Reamer		-	Cutter Wheel		1pc.	see product list
8	31	Cutter, Reamer		WL88	Roll Pin	Φ8x50	1	for TA type
8	32	Cutter, Reamer		A522	Reamer Cone		1	
8	33	Cutter, Reamer		WQ08	Steel Ball	Φ8	1	
8	34	Cutter, Reamer		5096	Spring		1	
8	35	Cutter, Reamer		A521	Reamer Arm		1	
8	36	Cutter, Reamer		A253	Reamer Shaft		1	
8	37	Cutter, Reamer		WL41	Roll Pin	Φ4x10	1	
8	38	Cutter, Reamer		1094	Reamer Knob		1	
8	39	Cutter, Reamer		0JRM1S	Reamer Complete Set		1 set	No.31-38 as a set