

RG-RH ***PORTABLE GROOVER H***

PARTS LIST

Date of issue: May 2010

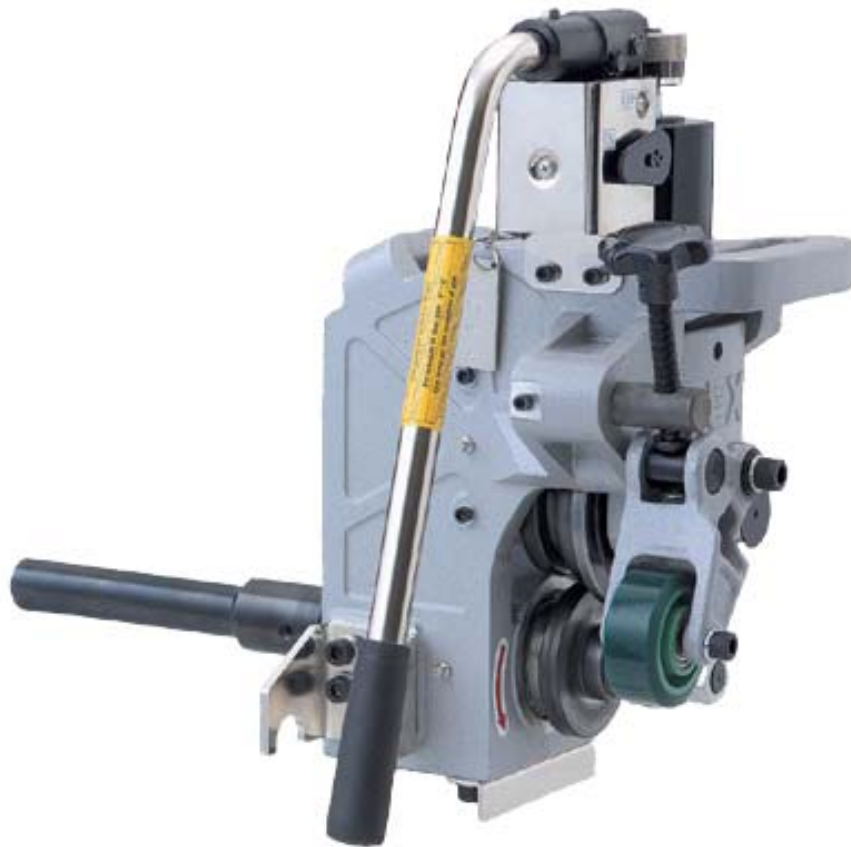

CONTENTS

1. ROLLER HOLDER
2. ROLLER SUPPORT
3. MOUNT BASE
4. MAIN SHAFT
5. HEAD STOCK

REX

PORTABLE GROOVER H - 1. ROLLER HOLDER

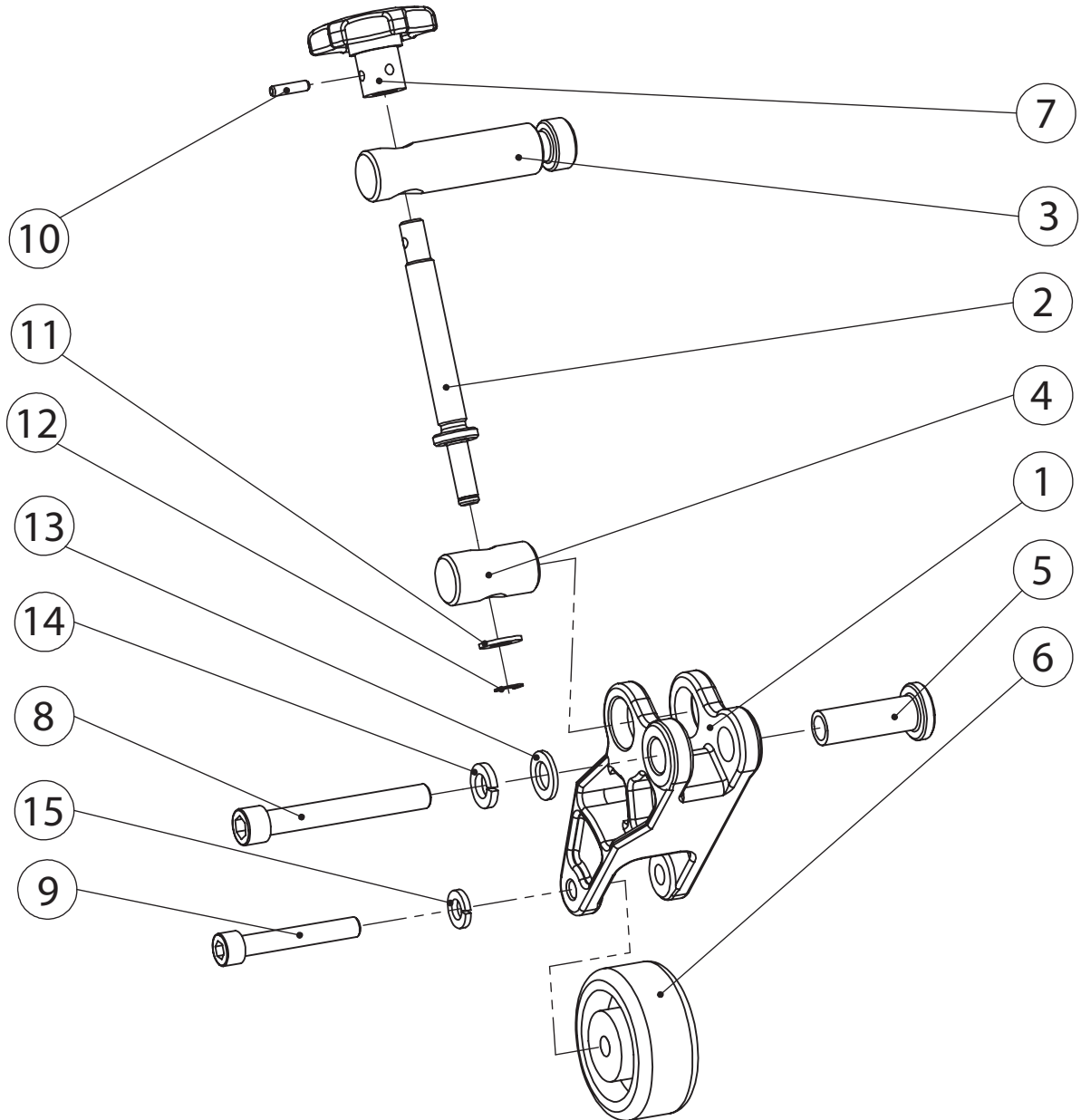

REX

PORTABLE GROOVER H - 2. ROLLER SUPPORT

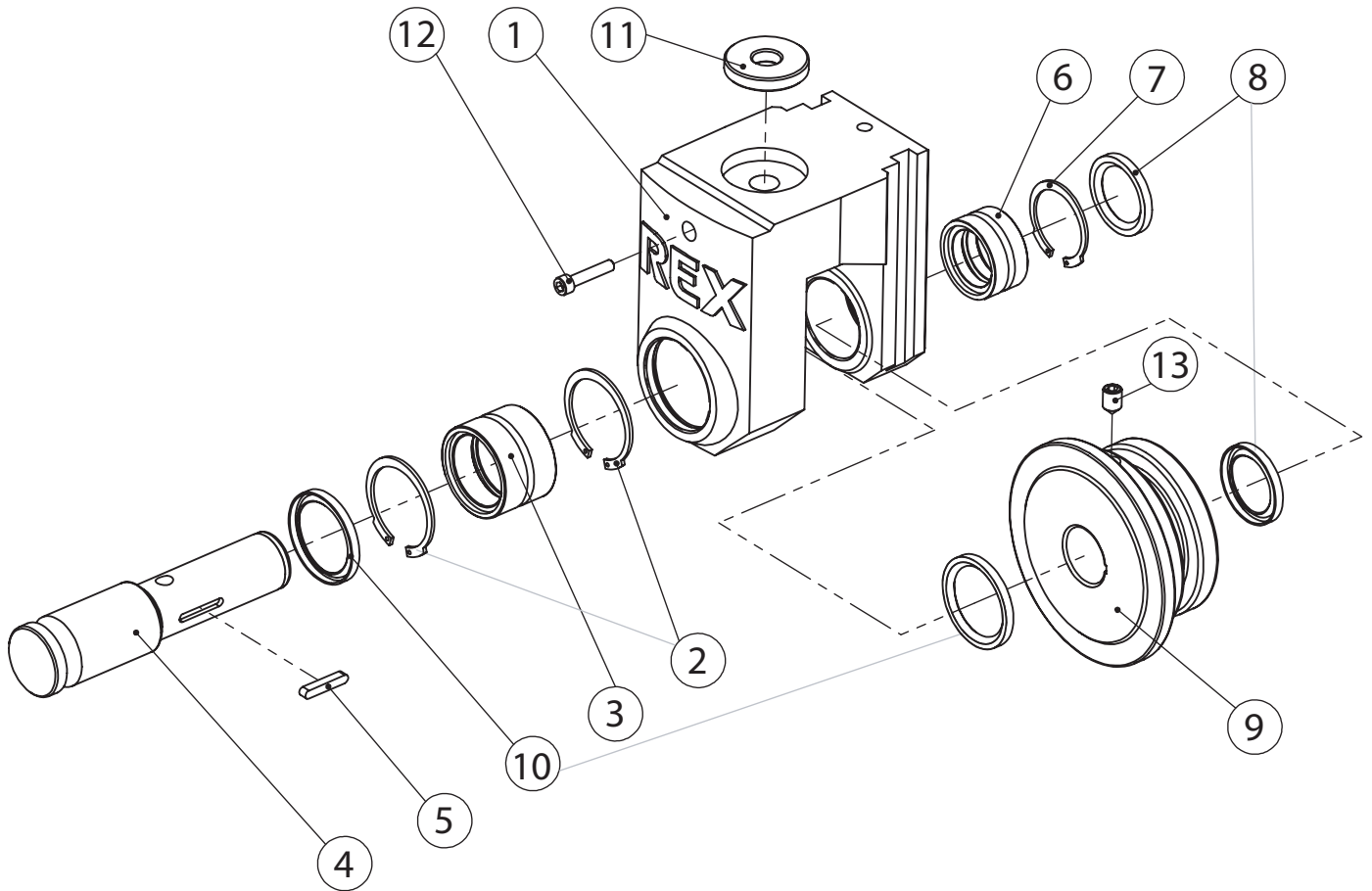

REX

PORTABLE GROOVER H - 3. MOUNT BASE

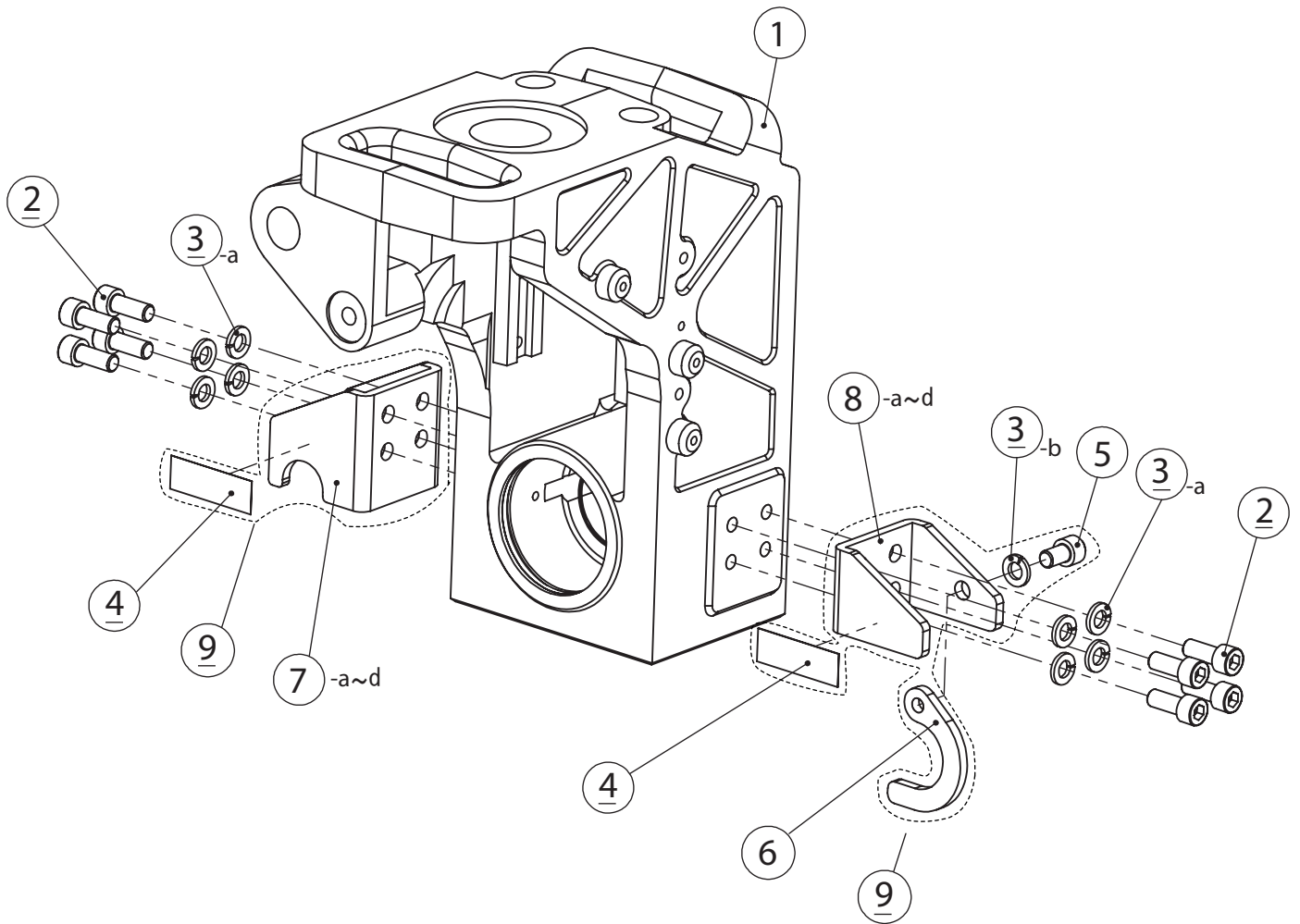

PORTABLE GROOVER H - 4. MAIN SHAFT

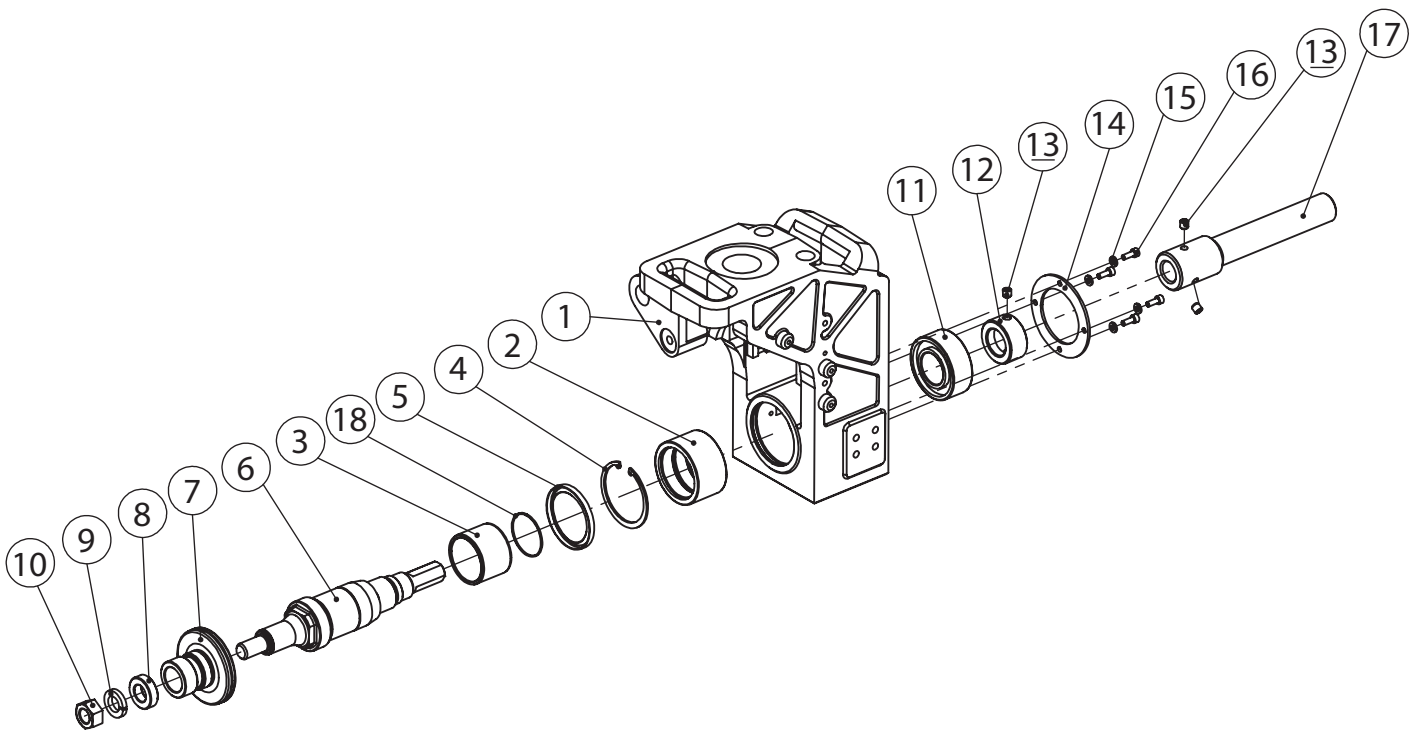

PORTABLE GROOVER H - 5. HEAD STOCK

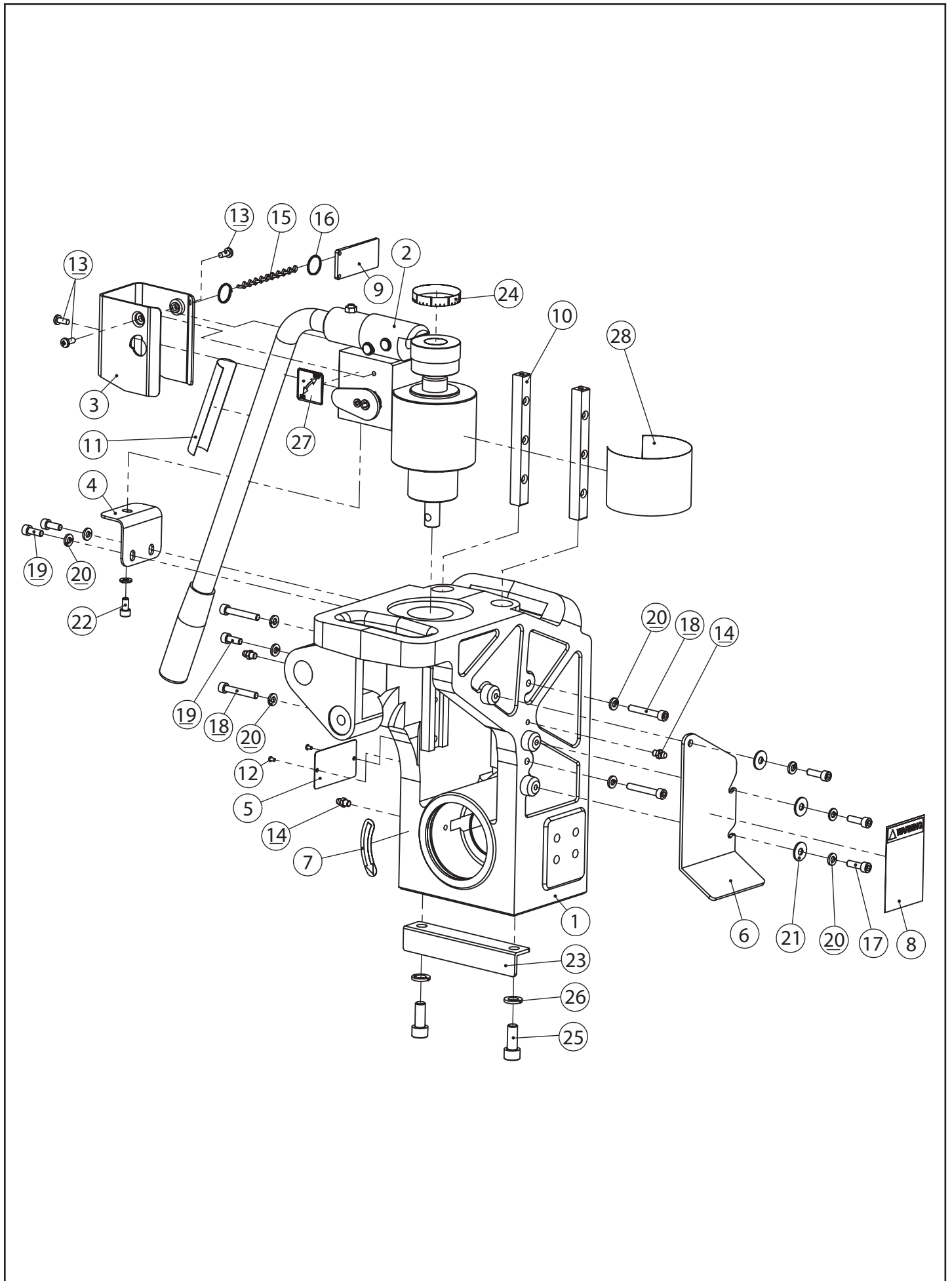

Page No.	Item No.	Page Title	Part No.	Part Name	Spec.	Q'ty	Remarks
1	1	1.ROLLER HOLDER	RE03	Roller holder		1	
1	2	1.ROLLER HOLDER	RE05	Feed screw		1	
1	3	1.ROLLER HOLDER	RE06	Roller holder pin A		1	
1	4	1.ROLLER HOLDER	RE07	Roller holder pin B		1	
1	5	1.ROLLER HOLDER	RE08	Roller holder collar		1	
1	6	1.ROLLER HOLDER	RX77	Roller		1	
1	7	1.ROLLER HOLDER	RJ92	Knob		1	
1	8	1.ROLLER HOLDER	W190	Socket head cap screw	M12 x 90/ Half thread	1	
1	9	1.ROLLER HOLDER	W00A	Socket head cap screw	M10 x 65/ Full thread	1	
1	10	1.ROLLER HOLDER	WL54	Roll pin	5 x 20	1	
1	11	1.ROLLER HOLDER	WI01	Flat washer	10	1	
1	12	1.ROLLER HOLDER	WY07	E-ring	7	1	
1	13	1.ROLLER HOLDER	WZG3	Washer	12/ Black	1	
1	14	1.ROLLER HOLDER	WG12	Spring washer	12	1	
1	15	1.ROLLER HOLDER	WG10	Spring washer	10	1	

Page No.	Item No.	Page Title	Part No.	Part Name	Spec.	Q'ty	Remarks
2	1	2.ROLLER SUPPORT	RE02	Roller support		1	
2	2	2.ROLLER SUPPORT	WZ52	Snap ring	1RTW52	2	
2	3	2.ROLLER SUPPORT	RJ52	Needle bearing	RNA6932	1	
2	4	2.ROLLER SUPPORT	RJ10	Roller shaft		1	
2	5	2.ROLLER SUPPORT	RJ20	Roller key		1	
2	6	2.ROLLER SUPPORT	RJ53	Needle bearing	RNA5928	1	
2	7	2.ROLLER SUPPORT	WZ45	Snap ring	1RTW45	1	
2	8	2.ROLLER SUPPORT	RJ58	Oil seal	AF1876E0	2	
2	9	2.ROLLER SUPPORT	RJL1	Upper roller		1	
2	10	2.ROLLER SUPPORT	RJ57	Oil seal	AF2340F0	2	
2	11	2.ROLLER SUPPORT	RE10	Washer		1	
2	12	2.ROLLER SUPPORT	W065	Socket head cap screw	M6 x 30	1	
2	13	2.ROLLER SUPPORT	W695	Socket set screw	M10 x 15 / Cup point	1	

Page No.	Item No.	Page Title	Part No.	Part Name	Spec.	Q'ty	Remarks
3	1	3.MOUNT BASE	RE01	Head stock		1	
3	2	3.MOUNT BASE	W002	Socket head cap screw	M10 x 25	8	
3	3-a	3.MOUNT BASE	WG10	Spring washer	M10	8	
3	3-b	3.MOUNT BASE	WG10	Spring washer	M10	1	OPTION COMMON PARTS
3	4-a	3.MOUNT BASE	5V64	Mount kit seal for 50		2	OPTION COMMON PARTS
3	4-b	3.MOUNT BASE	5V65	Mount kit seal for 80		2	OPTION COMMON PARTS
3	4-c	3.MOUNT BASE	5V66	Mount kit seal for 100		2	OPTION COMMON PARTS
3	4-d	3.MOUNT BASE	5V67	Mount kit seal for #300		2	OPTION COMMON PARTS
3	5	3.MOUNT BASE	W191	Socket head cap screw	M10 x 16	1	OPTION COMMON PARTS
3	6	3.MOUNT BASE	RE32	Hook		1	OPTION COMMON PARTS
3	7-a	3.MOUNT BASE	RE33	Base 50 Right		1	341560 M-HR1 MOUNT BASE 50
3	8-a	3.MOUNT BASE	RE34	Base 50 Left		1	341560 M-HR1 MOUNT BASE 50
3	7-b	3.MOUNT BASE	RE35	Base 80 Right		1	341561 M-HR2 MOUNT BASE 80
3	8-b	3.MOUNT BASE	RE36	Base 80 Left		1	341561 M-HR2 MOUNT BASE 80
3	7-c	3.MOUNT BASE	RE37	Base 100 Right		1	341562 M-HR3 MOUNT BASE 100
3	8-c	3.MOUNT BASE	RE38	Base 100 Left		1	341562 M-HR3 MOUNT BASE 100
3	7-d	3.MOUNT BASE	RE41	Base #300 Right		1	341563 M-HE1 MOUNT BASE #300
3	8-d	3.MOUNT BASE	RE42	Base #300 Left		1	341563 M-HE1 MOUNT BASE #300
3	9-a	3.MOUNT BASE	341560	Mount base kit 50		1 Set	No. 4~8
3	9-b	3.MOUNT BASE	341561	Mount base kit 80		1 Set	No. 4~8
3	9-c	3.MOUNT BASE	341562	Mount base kit 100		1 Set	No. 4~8
3	9-d	3.MOUNT BASE	341563	Mount base kit #300		1 Set	No. 4~8

Page No.	Item No.	Page Title	Part No.	Part Name	Spec.	Q'ty	Remarks
4	1	4.MAIN SHAFT	RE01	Head stock		1	
4	2	4.MAIN SHAFT	RJ51	Needle bearing		1	
4	3	4.MAIN SHAFT	RE14	Needle ring		1	
4	4	4.MAIN SHAFT	WX80	C-type retaining ring		1	
4	5	4.MAIN SHAFT	RJ56	Oil seal		1	
4	6	4.MAIN SHAFT	RE04	Main shaft		1	
4	7	4.MAIN SHAFT	RJL2	Lower roller	2 - 6"	1	
4	8	4.MAIN SHAFT	RJ96	Roller washer		1	
4	9	4.MAIN SHAFT	WG20	Spring washer	M20	1	
4	10	4.MAIN SHAFT	WC20	Hexagon nut	M20	1	
4	11	4.MAIN SHAFT	RJ54	Ball bearing		1	
4	12	4.MAIN SHAFT	RE09	Main shaft set nut		1	
4	13	4.MAIN SHAFT	W702	Socket set screw	cup point M10 x 10	2	
4	14	4.MAIN SHAFT	RE11	Bearing plate		1	
4	15	4.MAIN SHAFT	WG06	Spring washer	M6	4	
4	16	4.MAIN SHAFT	W062	Socket set screw	M16 x 16	4	
4	17	4.MAIN SHAFT	RM05	Connecting shaft		1	
4	18	4.MAIN SHAFT	RE15	Circlip		1	

Page No.	Item No.	Page Title	Part No.	Part Name	Spec.	Q'ty	Remarks
5	1	5.HEAD STOCK	RE01	Head stock		1	
5	2	5.HEAD STOCK	RE18	Pump	RXGB - 6A	1	
5	3	5.HEAD STOCK	RE12	Pump cover		1	
5	4	5.HEAD STOCK	RE13	Pump fixing plate		1	
5	5	5.HEAD STOCK	RN16	Name plate		1	
5	6	5.HEAD STOCK	RE17	Protective cover		1	
5	7	5.HEAD STOCK	RE19	Arrow sticker		1	
5	8	5.HEAD STOCK	RE20	Caution sticker		1	
5	9	5.HEAD STOCK	RJ47	Spacer		1	
5	10	5.HEAD STOCK	RJ09	Slide key		2	
5	11	5.HEAD STOCK	7A12	Pump sticker		1	
5	12	5.HEAD STOCK	WN34	Rivet		2	
5	13	5.HEAD STOCK	W265	Round head machine screw		3	
5	14	5.HEAD STOCK	J009	Grease nipple	M6	3	
5	15	5.HEAD STOCK	U577	Chain		1	
5	16	5.HEAD STOCK	U576	Key ring	20	2	
5	17	5.HEAD STOCK	W063	Socket head cap screw	M6 x 20	3	
5	18	5.HEAD STOCK	W067	Socket head cap screw	M6 x 20	4	
5	19	5.HEAD STOCK	W062	Socket head cap screw	M6 x 16	3	
5	20	5.HEAD STOCK	WG06	Spring washer	M6	11	
5	21	5.HEAD STOCK	WI63	Flat washer	6 x 19 x 1.6	3	
5	22	5.HEAD STOCK	W061	Socket head cap screw	M6 x 12	1	
5	23	5.HEAD STOCK	RE22	Angle base		1	
5	24	5.HEAD STOCK	6A63	Scale sticker		1	
5	25	5.HEAD STOCK	W002	Socket head cap screw	M10 x 25	2	
5	26	5.HEAD STOCK	WG10	Spring washer	M10	2	
5	27	5.HEAD STOCK	5V61	PG-H ON-OFF sticker		1	
5	28	5.HEAD STOCK	5V62	PG-H caution sticker		1	