

Sink Dropper
To be set below 'Slide Rails' level avoiding splashing.

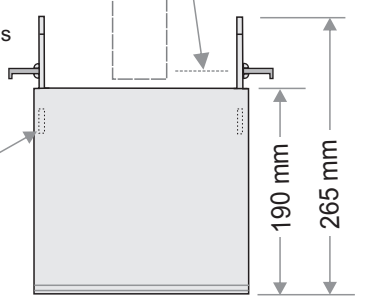

REMOVABLE TRAP SECTION

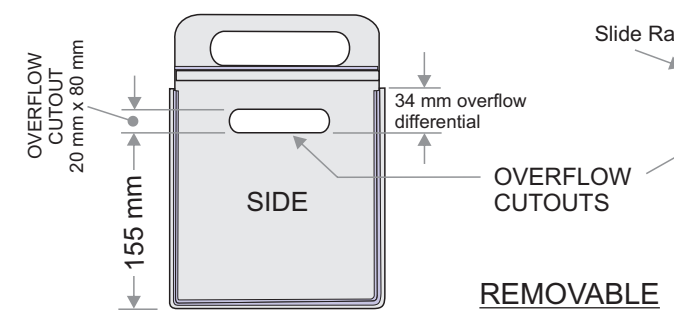
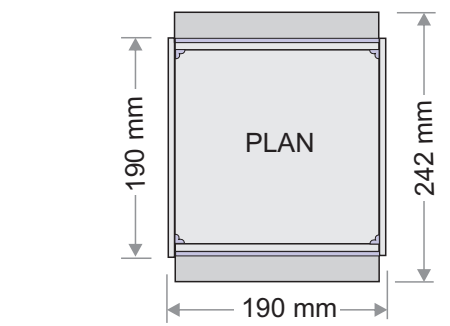

Manufactured under a quality system certified as complying with ISO 9001 by an accredited certification body



Drawing No.SP 33	CONSTRUCTED FROM 6mm PVC PLASTIC	NOT DRAWN TO SCALE
NAME	PLASTER / SOLIDS TRAP - SIDE OUTLET	
	CODE	PLTRAPSO ©
	COMPANY	STORM PLASTICS (SA) Pty Ltd
	VOLUME	Outer = 25.5 L, Inner = 5.6 L to overflow cutouts.
PIPE MATERIAL	Poly Vinyl Chloride - PVC	Mrch. 2013
DIMENSIONS	All dimensions shown are nominal in mm and subject to change without notice.	