

Convotherm maxx pro easyDial Combi Steamer

CXGBD6.10 GAS BOILER 7 x 1/1 GN

- Boiler system
- Natural Smart Climate™ (ACS+) cooking methods: Steam, Combi-steam, Convection
- Natural Smart Climate™ extra functions:
 - Crisp&Tasty - 5 moisture removal settings
 - BakePro - 5 levels of traditional baking
 - HumidityPro - 5 humidity settings
 - Controllable fan - 5 speed settings
- easyDial: all functions are set on one operating level
- ConvoClean fully automatic cleaning system
- HygieniCare
- USB port integrated in the control panel
- TriColor indicator ring - indicates the current operating status
- Steam generated by high-performance boiler outside the cooking chamber
- LED lighting in oven cavity
- Triple glass appliance door
- Right-hinged appliance door



Standard Features

- Cooking methods:
 - Steam (30-130°C) with guaranteed steam saturation
 - Combi-steam (30-250 °C) with automatic moisture control
 - Convection (30-250 °C) with optimised heat transfer
- Operation of easyDial user interface:
 - Central control unit, Convotherm-Dial (C-Dial)
 - Digital display
- Climate Management
 - Natural Smart Climate™ (ACS+), HumidityPro, Crisp&Tasty
- Quality Management
 - Airflow Management, BakePro, Multi-point core temperature probe
- Production Management
 - 99 cooking profiles each containing up to 9 steps
 - HACCP data storage
 - USB port
 - Regenerating function - regenerates products to their peak level
 - Preheat and cool down function
- Cleaning Management:
 - ConvoClean: Fully automatic cleaning system, with optional single-dose dispensing
- HygieniCare: safety by antibacterial surfaces
 - Hygienic Handles
- Door handle with safety latch and sure-shut function

- Adjustable appliance feet, from 100 mm to 125 mm
- Integrated recoil hand shower

Options

- Steam and vapour removal (built-in condensation hood)
- Sous-vide sensor, with external socket
- Core temperature sensor, with external socket
- Ethernet / LAN interface
- Available in various voltages

Accessories

- Stainless steel stand
- Stacking kit
- ConvoLink – HACCP and cooking profile management PC software
- Banquet system package: plate rack, mobile shelf rack, transport trolley, thermal cover (individual items are available)
- Care products for ConvoClean fully automatic cleaning system (multiple and single-dose dispensing)

Convotherm maxx pro easyDial Combi Steamer

CXGBD6.10 GAS BOILER 7 x 1/1 GN

Front view

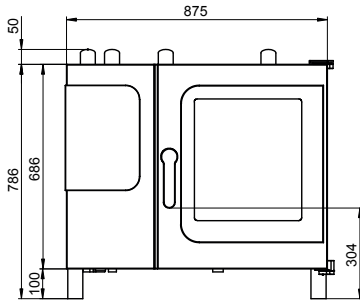

View from above with wall clearances

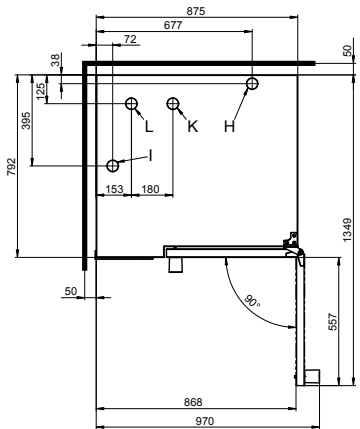

Connection points

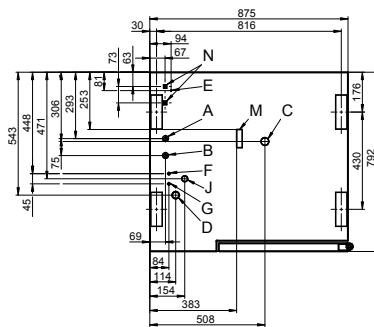

- A Water connection (for boiler)
- B Water connection (for cleaning, recoil hand shower)
- C Drain connection DN 50
- D Electrical connection
- E Equipotential bonding
- F Rinse-aid connection
- G Cleaning-agent connection
- H Air vent Ø 50 mm
- I Dry air intake Ø 50 mm
- J Gas supply
- K Convection burner exhaust outlet Ø 50 mm
- L Boiler burner exhaust outlet Ø 50 mm
- M Safety overflow 80 x 25 mm
- N RJ45 Ethernet port

DIMENSIONS

Width	875 mm
Depth	792 mm
Height	786 mm
Weight	140kg

PACKED DIMENSIONS

Width	1100 mm
Depth	940 mm
Height	1025 mm
Weight (including cleaning system)	165 kg

Safety clearances*

Rear	50 mm
Right	50 mm
Left (larger recommended for servicing)	50 mm
Top (for ventilation)	1000 mm

*Heat sources must lie at a minimum distance of 500 mm from the appliance.

INSTALLATION REQUIREMENTS

For precise installation instructions please refer to the units installation manual

LOADING CAPACITY

Max. number of food containers	
Shelf distance	68mm
GN 1/1 (with standard rack)	7
600 x 400 baking sheet (with appropriate rack)	5
Max. loading weight GN 1/1 / 600 x 400	
Per combi steamer	30 kg
Per shelf	15 kg

ELECTRICAL SUPPLY

1N~ 230-240V 50/60Hz (1P+N+E)	
Rated power consumption	0.6kW
Rated current	2.7 A
Fuse	16 A
RCD (GFCI), frequency converter	Type A
(singlephase)	(recommended), type B (optional)
3 Pin plug (10 Amp)	Cordset fitted

GAS SUPPLY

Gas Connection for natural or LPG	R3/4
Installation conditions	customer premise
Nominal gas consumption	42 MJ/hr
Convection power output	42 MJ/hr
Steam generator output	41 MJ/hr

Supply flow pressure

Natural Gas	1.13kPa – 3kPa
LPG	2.75kPa – 4kPa

WATER CONNECTION

Water supply

2 x G 3/4" permanent connection, optionally including connecting pipe (min. DN13 / 1/2")

Flow pressure 150 - 600 kPa (1.5 - 6 bar)

Appliance drain

Drain version Permanent connection (recommended) or funnel waste trap DN50 (min. internal Ø: 46 mm)

Type min. 3.5% (2°)

Slope for waste-water pipe min. 3.5% (2°)

WATER QUALITY

Drinking water

Total hardness 4-20 °dh / 70 – 360 ppm /

Cleaning, recoil shower 7 – 35°TH / 5 – 25°e

Properties

pH 6.5 - 8.5

Cl- (chloride) max. 60 mg/l

Cl₂ (free chlorine) max. 0.2 mg/l

SO₄²⁻ (sulphate) max. 150 mg/l

Fe (iron) max. 0.1 mg/l

Temperature max. 40°C

Electrical conductivity min. 20 µS/cm

EMISSIONS

Heat output

Latent heat 2100 kJ/h / 0.58 kW

Sensible heat 3500 kJ/h / 0.97 kW

Waste water temperature max. 80 °C

Noise during operation max. 70 dBA

STACKING KIT

Permitted combinations 6.10 on 6.10 / 6.10 on 10.10 (Gas on gas appliance)



moffat.com.au
moffat.co.nz

Australia
moffat.com.au

Moffat Pty Limited

Victoria/Tasmania
740 Springvale Road
Mulgrave, Victoria 3170
Telephone +61 3-9518 3888
Facsimile +61 3-9518 3833
vsales@moffat.com.au

New South Wales
Telephone +61 2-8833 4111
nswsales@moffat.com.au

South Australia
Telephone +61 3-9518 3888
vsales@moffat.com.au

Queensland /
Northern Territory
Telephone +61 7-3630 8600
qldsales@moffat.com.au

Western Australia
Telephone +61 8-9413 2400
wasales@moffat.com.au

New Zealand
moffat.co.nz

Moffat Limited

Rolleston
45 Illinois Drive
Izone Business Hub
Rolleston 7675
Telephone +64 3-983 6600
Facsimile +64 3-983 6660
sales@moffat.co.nz

Auckland
Telephone +64 9-574 3150
sales@moffat.co.nz

In line with policy to continually develop and improve its products, Moffat Limited reserves the right to change specifications and design without notice.

© Copyright Moffat Ltd
AN.CON.S.2101



Distributor:



Chefs Hat Australia Pty. Ltd
131 Cecil St
South Melbourne, VIC 3205

p: +61 3 9682 1441
e: sales@chefshat.com.au