

## GOGHT9



## PRODUCT FEATURES

- Deck forced heating
- Single glazed glass with front tilting hinged glass
- Sliding glazed rear doors
- Deck forced heating
- Two adjustable shelves
- Ticket strips on shelf and deck
- Under shelf and canopy LED lights

Maximum shelf load weight 15kg spread evenly

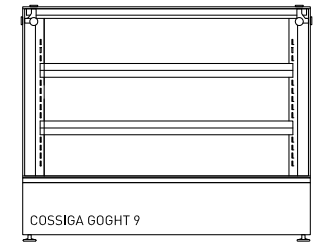
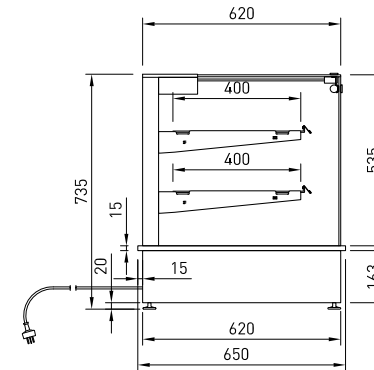
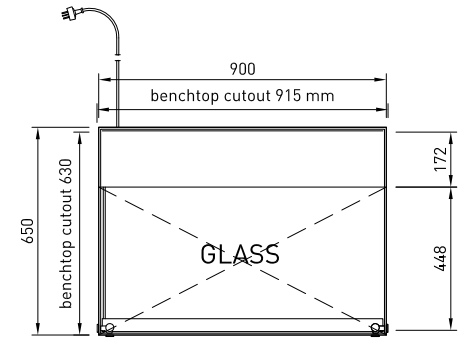

## CABINET DIMENSIONS & SPECIFICATIONS

Prior to installation see, installation guidelines, ventilation requirements and drainage options documents

MODEL	CABINET			SHELVING WEIGHT KG	SHELVING 2+ BASE	OPERATING TEMP DEG C	SHELF W X D	BASE TRAY W X D	TOTAL FOOD 100MM UNITS	DISPLAY M <sup>2</sup>	INTERNAL VOLUME M <sup>3</sup>	FREQUENCY 50/60 HZ	REFRIGERANT N/A	POWER		CONNECTION ELECTRICAL POWER CORD 2200MM		VOLTAGE 220-240V	PACKED FOR SHIPPING			
	LENGTH [MM]	DEPTH [MM]	HEIGHT [MM]											KWH	AMP	NZ/AUS 10 AMP 3 PIN PLUG	UK 13 AMP 3 PIN PLUG		LENGTH [MM]	DEPTH [MM]	HEIGHT [MM]	WEIGHT
GOGHT9	900	650	733	99	2+ BASE	68 -80	787 X 430	770 X 410	96	0.65	0.91	50/60 HZ	N/A	1.24	5.4	3 PIN PLUG	3 PIN PLUG	220-240V	1000	750	1100	106