

# CAX1800

## User Manual

05-2021 / v1.1

---

### **Edimax Technology Co., Ltd.**

No. 278, Xinhua 1st Rd., Neihu Dist., Taipei City, Taiwan

Email: [support@edimax.com.tw](mailto:support@edimax.com.tw)

---

### **Edimax Technology Europe B.V.**

Fijenhof 2, 5652 AE Eindhoven, The Netherlands

Email: [support@edimax.nl](mailto:support@edimax.nl)

---

### **Edimax Computer Company**

530 Technology Drive Suite 100, Irvine, CA 92618, USA

Email: [support@edimax.us](mailto:support@edimax.us)

# Contents

---

<b>I.</b>	<b>Product Information.....</b>	<b>1</b>
I-1.	Package Contents.....	2
I-2.	System Requirements .....	4
I-3.	Hardware Overview .....	4
I-4.	LED Status .....	5
<b>II.</b>	<b>Hardware Installation .....</b>	<b>6</b>
<b>III.</b>	<b>Quick Setup (AP Mode) .....</b>	<b>14</b>
<b>IV.</b>	<b>Basic Settings.....</b>	<b>16</b>
IV-1.	Changing IP Address.....	17
IV-2.	Changing SSID For 2.4GHz Wireless Networ.....	18
IV-3.	Configuring Security Settings of 2.4GHz wireless network....	19
IV-4.	Changing Security Setting for 5GHz wireless network .....	21
IV-5.	Changing Admin Name and Password .....	22
IV-6.	Changing Date and Time .....	22
<b>V.</b>	<b>CAX1800 Settings.....</b>	<b>23</b>
V-1.	Information .....	23
i.	System Information .....	24
ii.	Wireless Clients .....	27
iii.	Wireless Monitor.....	28

iv. DHCP Clients.....	29
v. Log .....	29
V-2. Network Settings.....	31
i. LAN-side IP Address.....	31
ii. LAN Port.....	34
iii. IGMP Snooping.....	35
iv. STP Management.....	35
v. VLAN .....	36
V-3. Wireless Settings.....	37
i. Basic (2.4GHz 11bgn).....	38
ii. Advanced (2.4GHz 11bgn) .....	41
iii. Security (2.4GHz 11bgn) .....	44
iv. WDS (2.4GHz 11bgn) .....	46
v. Guest Network (2.4GHz 11bgn) .....	48
vi. 5GHz 11ac 11an.....	48
vii. WPS .....	49
viii. RADIUS (RADIUS Settings) .....	49
ix. Internal Server.....	51
x. RADIUS Accounts.....	53
xi. MAC Filter .....	55
xii. WMM.....	57

<i>xiii. Schedule</i> .....	<b>59</b>
<i>xiv. Traffic Shaping</i> .....	<b>61</b>
<i>xv. Bandsteering</i> .....	<b>62</b>
<b>V-4. Management</b> .....	<b>63</b>
<i>i. Admin</i> .....	<b>64</b>
<i>ii. Date and Time</i> .....	<b>66</b>
<i>iii. Syslog Server</i> .....	<b>67</b>
<i>iv. Ping Test</i> .....	<b>69</b>
<i>v. Traceroute Test</i> .....	<b>70</b>
<b>V-5. Advanced</b> .....	<b>71</b>
<i>i. LED Settings</i> .....	<b>71</b>
<i>ii. Update Firmware</i> .....	<b>72</b>
<i>iii. Save / Restore Settings</i> .....	<b>73</b>
<i>iv. Factory Default</i> .....	<b>74</b>
<i>v. Reboot</i> .....	<b>75</b>
<b>V-6. Operation Mode</b> .....	<b>76</b>
<b>VI. Edimax Pro NMS</b> .....	<b>77</b>
<b>VI-1. Quick Setup – NMS</b> .....	<b>78</b>
<b>VI-2. Webpage Layout - NMS</b> .....	<b>85</b>
<b>VI-3. NMS Features</b> .....	<b>92</b>
<b>VI-4. Dashboard</b> .....	<b>94</b>

i. <i>System Information</i> .....	95
ii. <i>Devices Information</i> .....	95
iii. <i>Managed AP</i> .....	96
iv. <i>Managed AP Group</i> .....	98
v. <i>Active Clients</i> .....	101
vi. <i>Active Users</i> .....	101
VI-5. <i>Zone Plan</i> .....	102
ii. <i>Control</i> .....	106
VI-6. <i>NMS Monitor</i> .....	108
i. <i>AP</i> .....	108
ii. <i>Managed AP Group</i> .....	111
iii. <i>WLAN</i> .....	114
iv. <i>Clients</i> .....	116
v. <i>Users</i> .....	117
vi. <i>Rogue Devices</i> .....	118
vii. <i>Information</i> .....	119
VI-7. <i>NMS Settings</i> .....	123
i. <i>Access Point</i> .....	123
ii. <i>WLAN</i> .....	140
iii. <i>RADIUS</i> .....	145
iv. <i>Access Control</i> .....	153

<b>v. Guest Network .....</b>	<b>156</b>
<b>vi. Users .....</b>	<b>160</b>
<b>vii. Guest Portal .....</b>	<b>161</b>
<b>viii. Zone Edit .....</b>	<b>171</b>
<b>ix. Schedule.....</b>	<b>173</b>
<b>x. Smart Roaming .....</b>	<b>174</b>
<b>xi. Device Monitoring.....</b>	<b>175</b>
<b>xii. Firmware Upgrade .....</b>	<b>176</b>
<b>xiii. Advanced .....</b>	<b>177</b>
<b>VI-8. Local Network .....</b>	<b>179</b>
<b>i. Network Settings.....</b>	<b>179</b>
<b>ii. 2.4GHz 11bgn.....</b>	<b>184</b>
<b>iii. 5GHz 11ac 11an.....</b>	<b>199</b>
<b>iv. WPS .....</b>	<b>209</b>
<b>v. RADIUS.....</b>	<b>211</b>
<b>vi. MAC Filter .....</b>	<b>216</b>
<b>vii. WMM.....</b>	<b>218</b>
<b>viii. Schedule.....</b>	<b>220</b>
<b>VI-9. Local Settings .....</b>	<b>222</b>
<b>i. Operation Mode.....</b>	<b>222</b>
<b>ii. Management .....</b>	<b>230</b>

<i>iv. Advanced</i> .....	<b>235</b>
<b>VI-10. Toolbox</b> .....	<b>240</b>
<i>i. Network Connectivity</i> .....	<b>240</b>
<b>VII. WPS</b> .....	<b>242</b>
<b>VIII. Reset</b> .....	<b>244</b>

## I. Product Information

---

The CAX1800 with the latest emerging IEEE 802.11ax Wi-Fi 6 technology effortlessly create a reliable internet connection. Place the CAX1800 between the router and the location where you need better wireless coverage and enjoy high-speed wireless connection throughout your home or office.

You can find all supporting documents from the link below or via QR Code:

<https://www.edimax.com/download>



(Once you've visited the Edimax official website, please enter the model no. "CAX1800" into the search box to search for your product.)

### Download

---

To select your product and find related download materials, enter the model number into the search box on the right side or follow the simple steps below:

\*Feel free to contact us anytime if you need help or if you can't find your product.

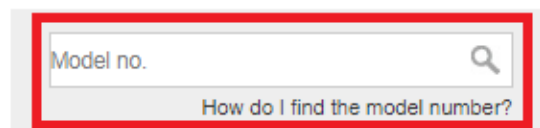
A screenshot of a search box on a website. The search box is rectangular with a light gray background and a red border. Inside the box, the text "Model no." is visible on the left, and a magnifying glass icon is on the right. Below the search box, the text "How do I find the model number?" is displayed.

# I-1. Package Contents

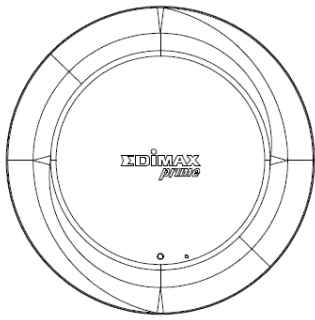

**CAX1800**

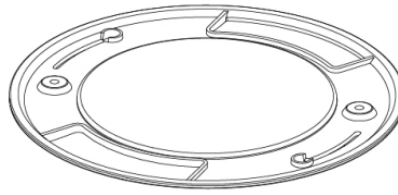

**Ceiling Mount Bracket**

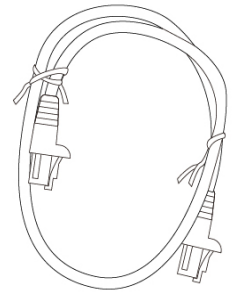

**Ethernet Cable**

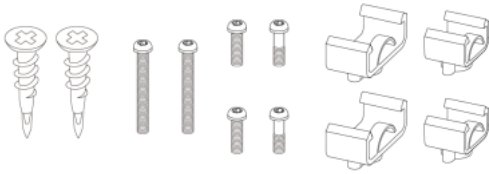

**T-Rail Mounting Kit & Screws**



**Manual**

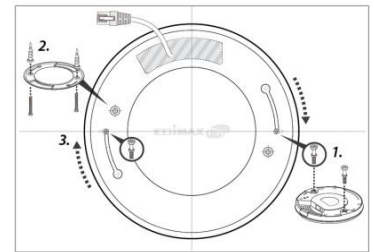

**Ceiling Mount Screw Template**

# Screws Size:

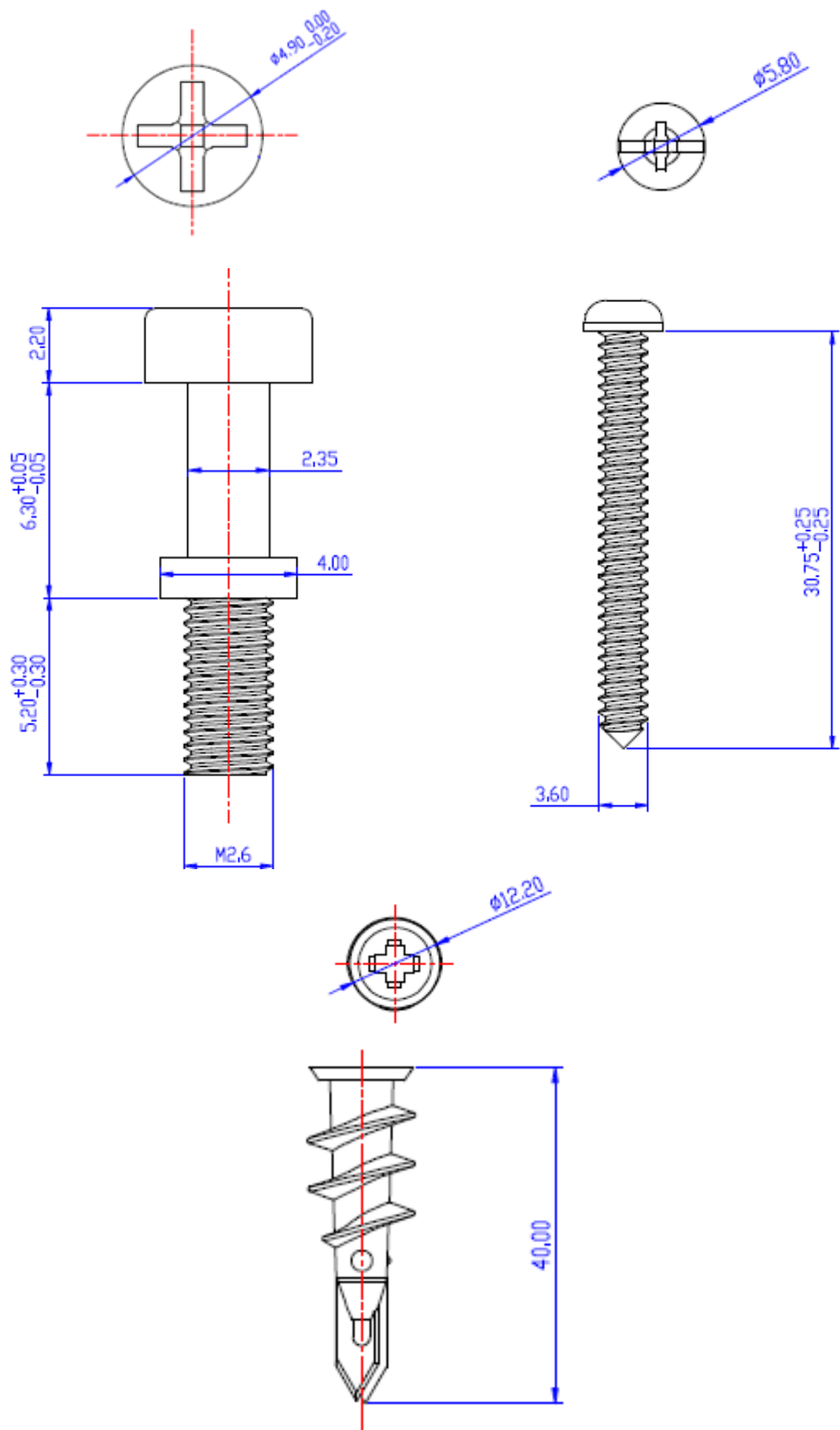

## I-2. System Requirements

- Existing cable/DSL modem & router
- Computer with web browser for AP configuration

## I-3. Hardware Overview

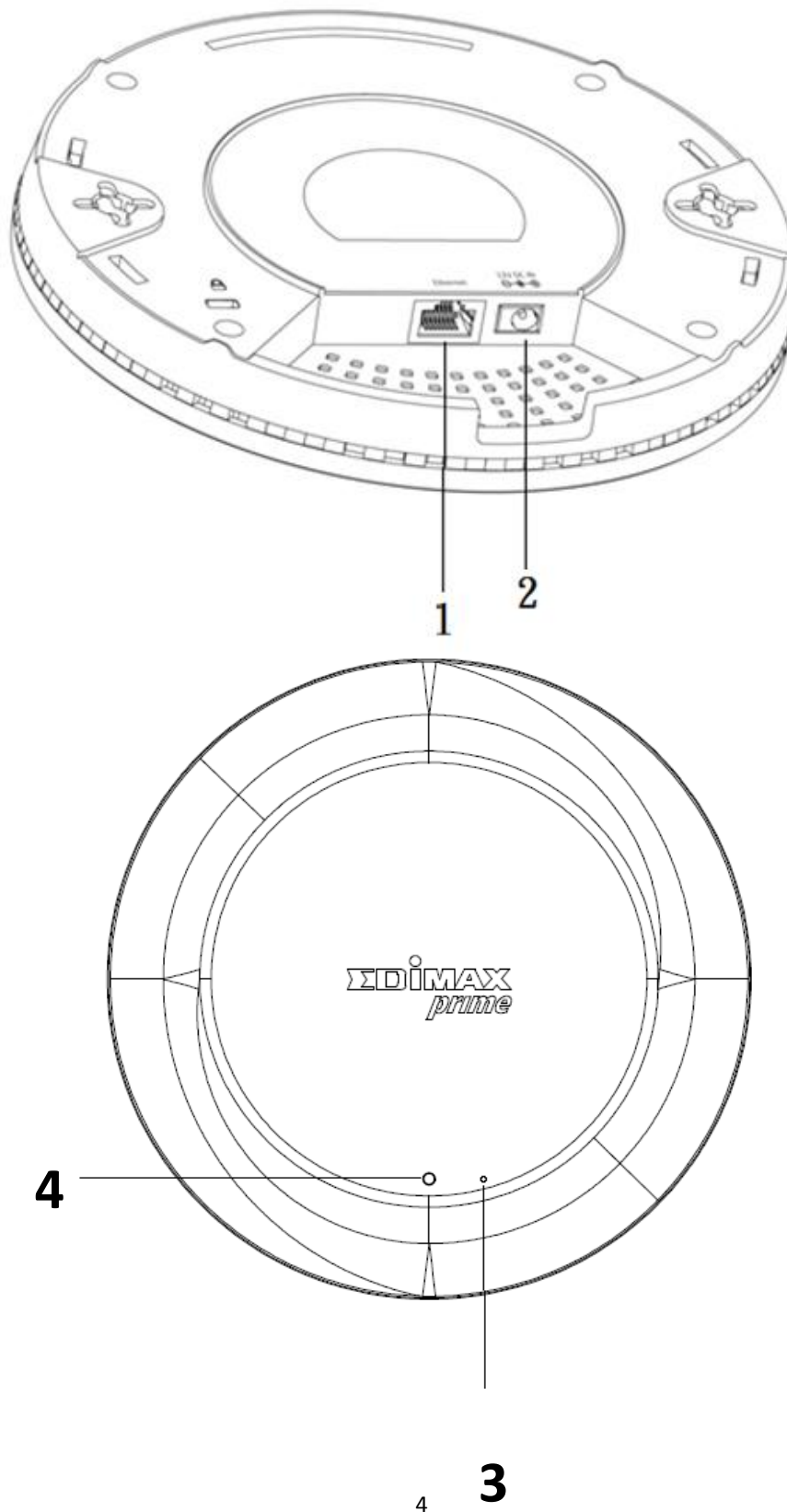

No.	Description
1	Ethernet Port (PoE)
2	Power Jack (12V/1.5A)
3	Reset Button
4	LED

#### I-4. LED Status

Color	Status	Description
Blue	On	Power is on.
	Flashing Slowly	Upgrading firmware.
	Flashing Quickly	Resetting to factory defaults.
Red	On	Starting up.
	Flashing	Error.
Off	Off	Power is off.

## II. Hardware Installation

---

This section will guide you through the steps to set up your CAX1800.

### Router or Switch:

Connect the AP to a router or a PoE switch using an Ethernet cable.

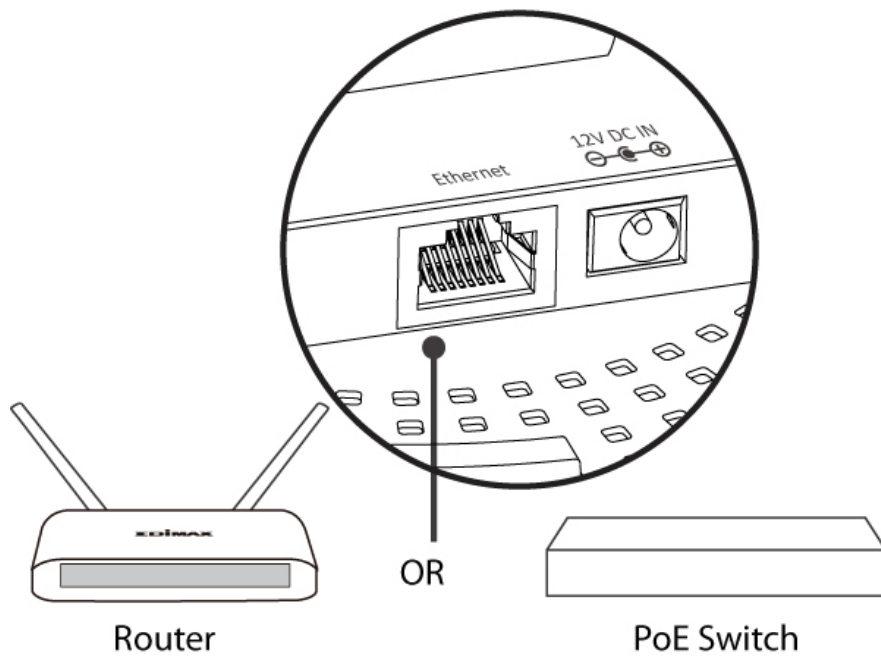

## II-1. Connect AP to a router

If router is used, connect the power adapter to the AP and plug the power adapter into a power supply. Please wait a moment for the AP to start up. The AP is ready when the LED is **Blue**.

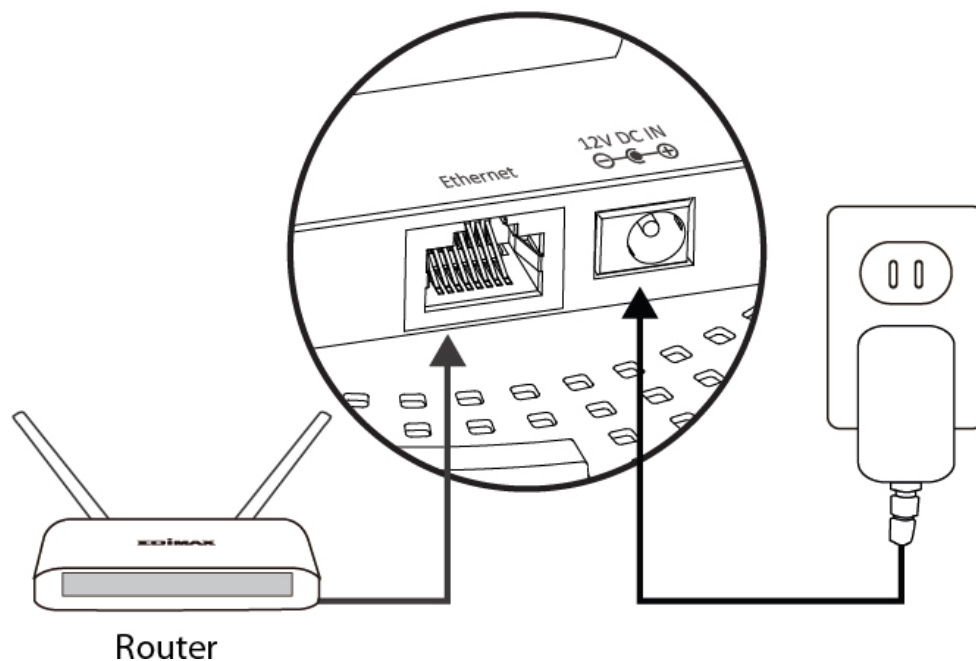

## II-2. Connect AP to a switch

If PoE switch is used, make sure the Ethernet cable is connected to Ethernet port from the PoE switch. The AP will be powered by the switch. Please wait a moment for the AP to start up. The AP is ready when the LED is **Blue**.

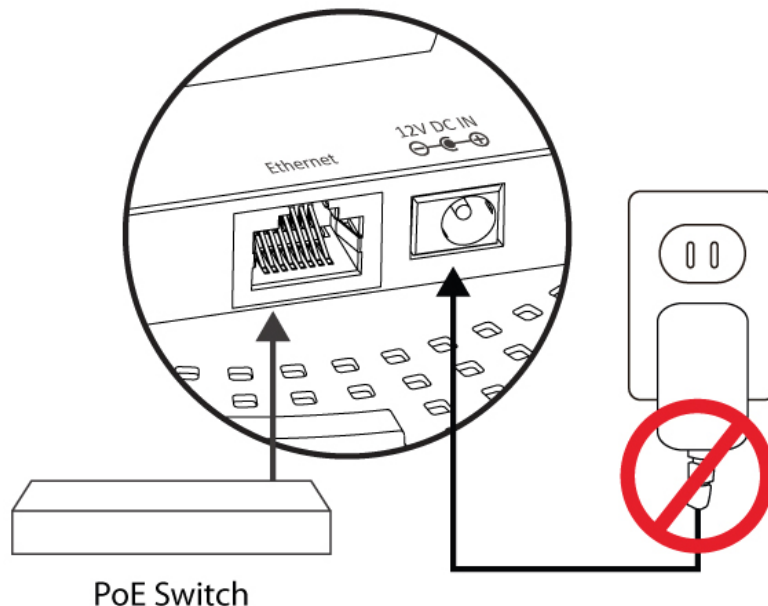

 **Do not use the power adapter if you are using a PoE switch.**

## II-3. Mounting

To mount the device to a ceiling, please follow the instructions below and refer to diagram **A & B**.

### Wooden Ceiling:

Please refer to the figure below:

1. By using the holes **A** on the ceiling bracket, identify and mark correct screw positions of the desired mounting location.
2. Where necessary, drill a hole (of radius smaller than the radius of the provided screws) on each of the marked screw positions.

3. Fix the ceiling mount bracket to the desired location by inserting the ceiling fixing screws **B** through the bracket ceiling holes **A**. Tighten the ceiling fixing screws **B** to the marked screw position using a screw driver to fix the bracket in place.
4. Fix the bracket rail screws **C** into the holes **D** on the device using a screw driver. The cap of the screws should be protruding outwardly from the holes **D**.
5. Insert the bracket rail screws **C** into the device fixing holes **E**.
6. Twist the device as the bracket rail screws **C** slide through the bracket rail **F**.  
Twist the device all the way until you feel that it is fixed in position.

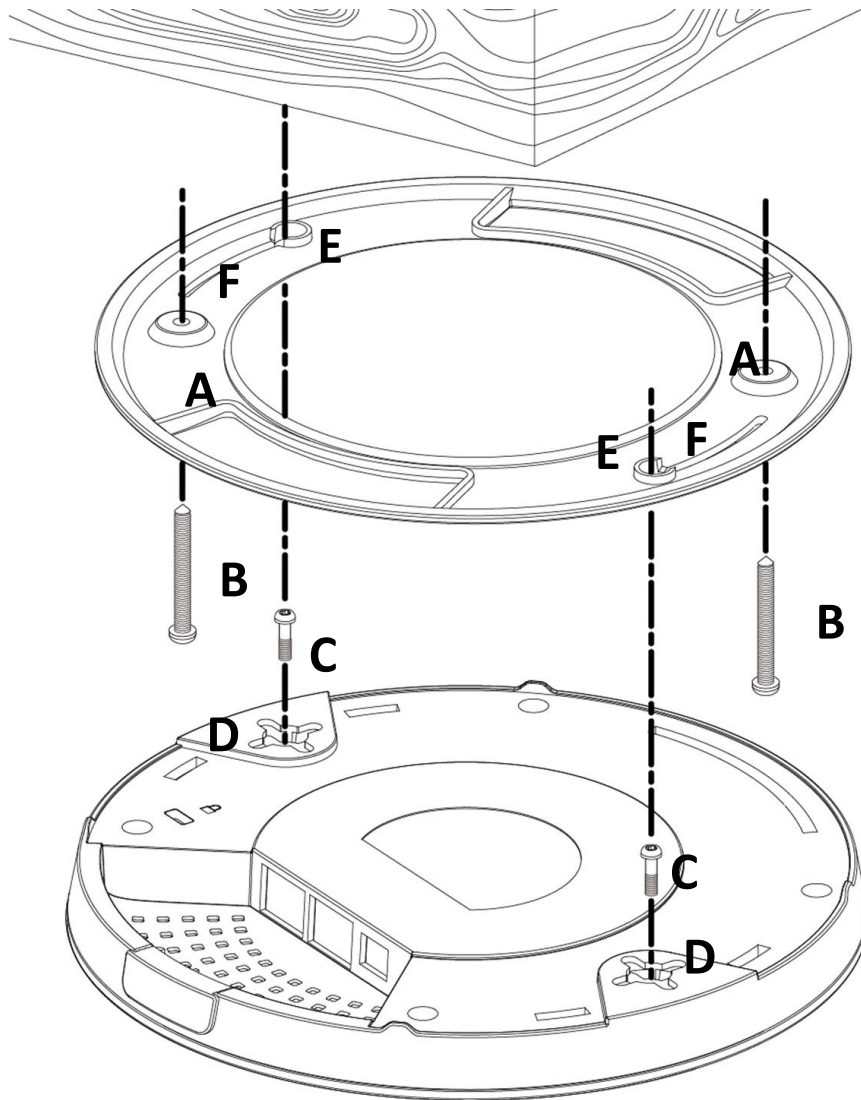

## Other Ceiling:

Please refer to the figure below:

1. By using the holes **A** on the ceiling bracket, identify and mark correct screw positions of the desired mounting location.
2. Where necessary, drill a hole on each of the marked screw positions.
3. Insert the anchors **G** into the holes (use a screw driver where necessary) at the marked screw positions.
4. Fix the ceiling mount bracket to the desired location by inserting the ceiling fixing screws **B** through the bracket ceiling holes **A**. Tighten the ceiling fixing screws **B** onto the anchors **G** using a screw driver to fix the bracket to the ceiling.
5. Fix the bracket rail screws **C** into the holes **D** on the device using a screw driver. The cap of the screws should be protruding outwardly from the holes **D**.
6. Insert the bracket rail screws **C** into the device fixing holes **E**.
7. Twist the device as the bracket rail screws **C** slide through the bracket rail **F**.  
Twist the device all the way until you feel that it is fixed in position.

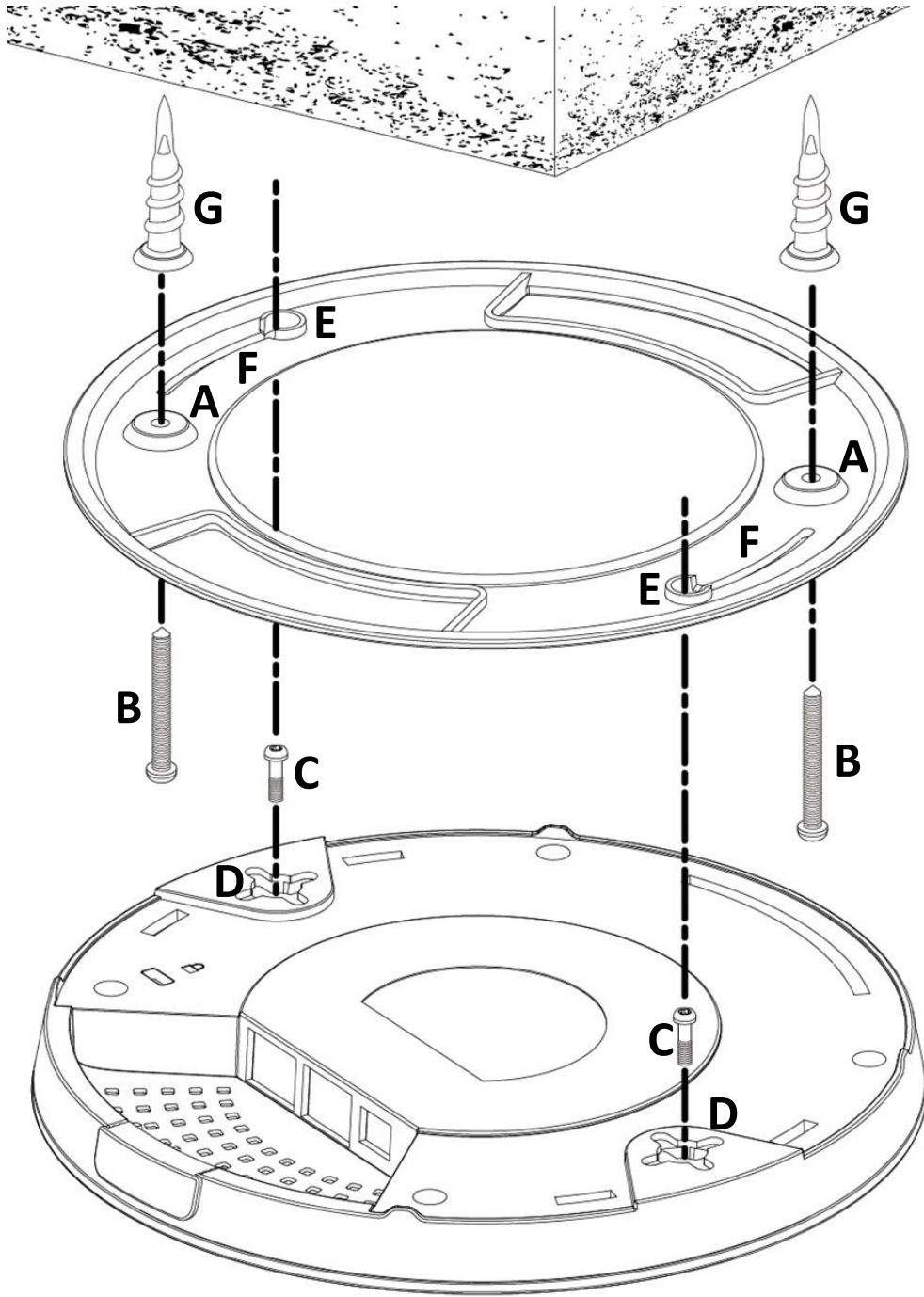

## T-Rail Mount:

To mount the device to a T-Rail, please follow the instructions below and refer to the diagrams below.

1. Select the correct size T-Rail bracket included in the package contents.
2. Attach the selected T-Rail brackets **A** to holes **B** using bracket fixing screws **C**.
3. Clip the device onto the T-Rail **D** using the now attached T-Rail brackets **A**.

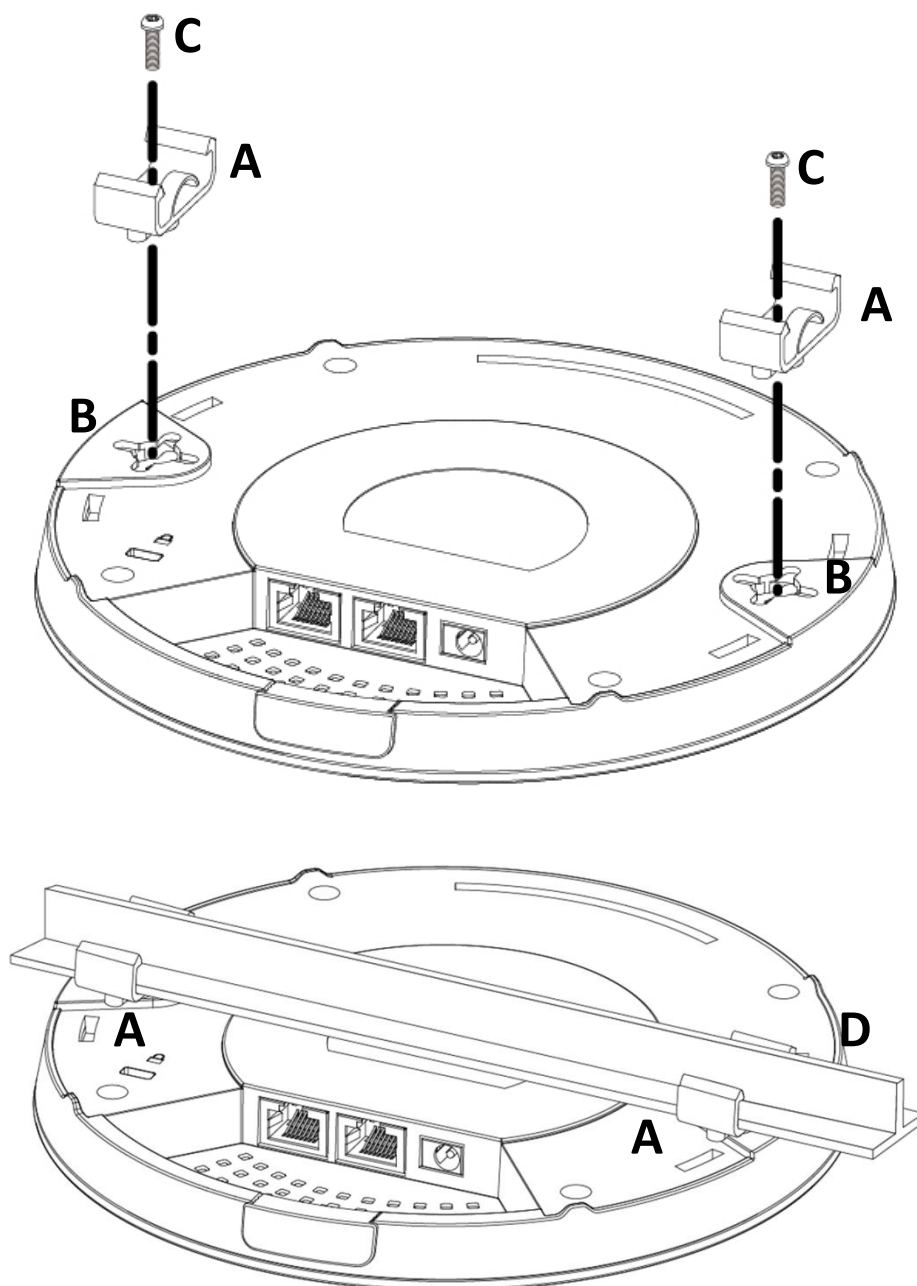

 **If you need more space between the device and the T-Rail, additional cushion bracket E can be added between T-Rail brackets A and holes B (use the longer screws included).**

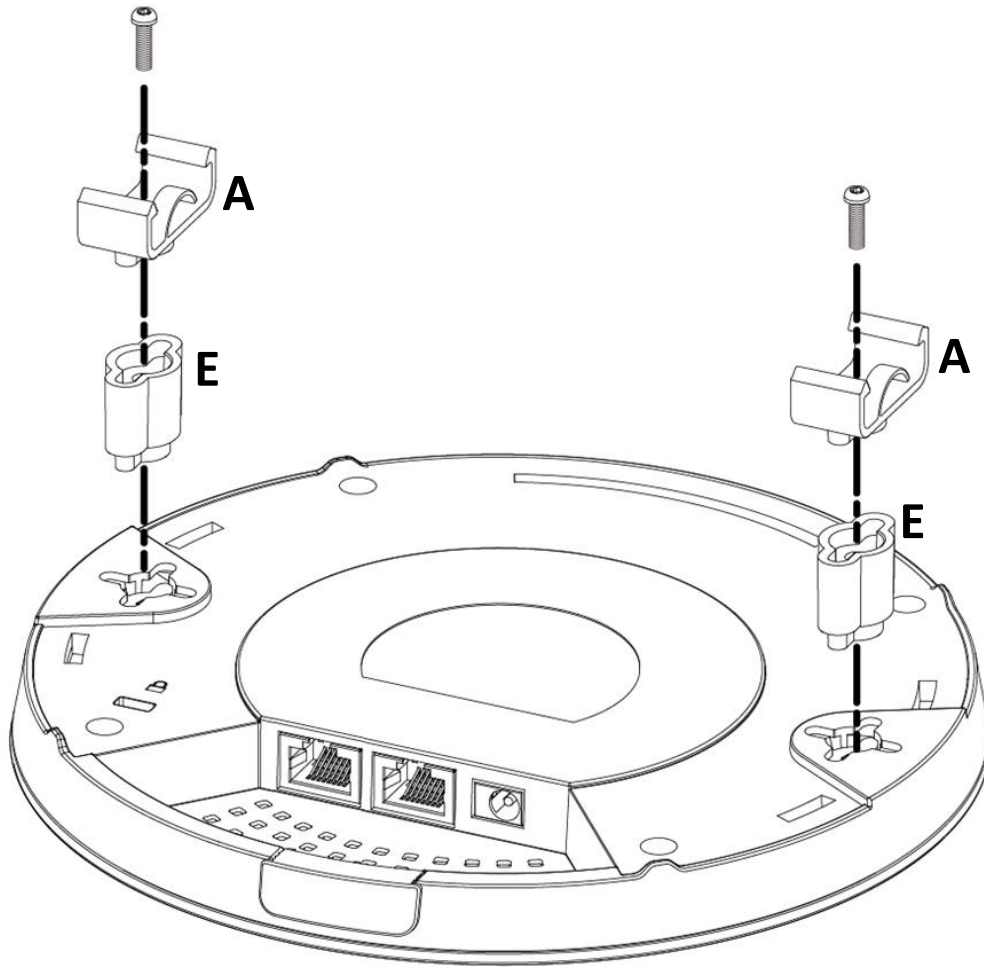

### III. Quick Setup (AP Mode)

---

This quick installation section will help you setup your AP in its default AP mode and configure its basic settings.

Please follow the steps below:

1. Enter the AP's default IP address "192.168.2.2" into the URL bar of a web browser.



192.168.2.2/

 **Please ensure to set your computer's IP address to "192.168.2.X" where X is a number in the range 3 ~ 100.**

2. You will be prompted for a username and password. Enter the default username "admin" and password "1234".

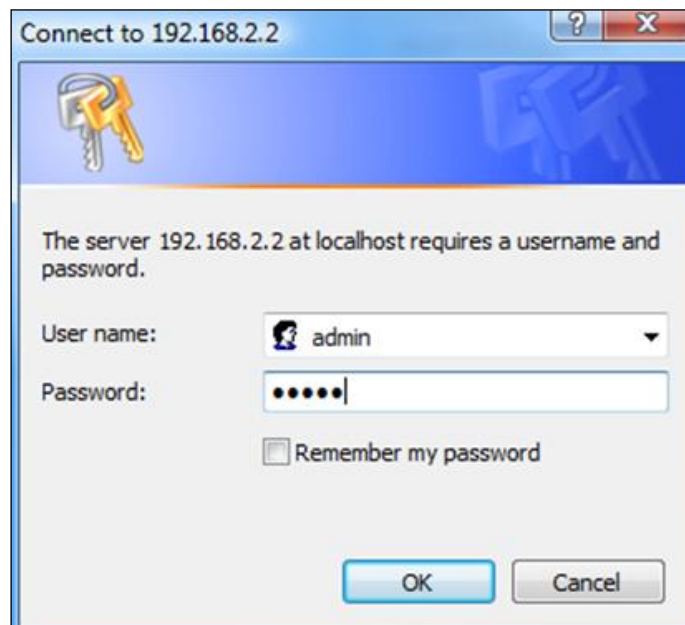

Connect to 192.168.2.2

The server 192.168.2.2 at localhost requires a username and password.

User name:

Password:

Remember my password

OK Cancel

3. Home screen will be shown.

The screenshot displays the EDIMAX CAX1800 web management interface. The top navigation bar includes 'Home | Logout | Global (English)'. The main menu contains 'Information', 'Network Settings', 'Wireless Settings', 'Management', 'Advanced', and 'Operation Mode'. The left sidebar shows 'Information' with sub-items: 'System Information', 'Wireless Clients', 'Wireless Monitor', 'DHCP Clients', and 'Log'. The main content area is titled 'System Information' and contains three sections: 'System', 'Wired LAN Port Settings', and 'Wireless 2.4GHz'. The 'System' section lists various parameters, with the 'Default Gateway' value '192.168.2.1' highlighted by a red box. The 'Wired LAN Port Settings' section shows 'LAN1' as 'Connected (100 Mbps Full-Duplex)'. The 'Wireless 2.4GHz' section shows 'Status' as 'Enabled' and 'RSSI' as '0'. The footer contains the copyright notice: 'Copyright 2017 © EDIMAX Technology Co., Ltd. All Rights Reserved'.

System	
Model	CAX1800
Product Name	AP00037FBADBAD
Uptime	0 day 00:02:37
System Time	2012/01/01 00:02:08
Boot from	Internal memory
Firmware Version	1.0.0
MAC Address	[REDACTED]
IP Address	192.168.2.101 <input type="button" value="Refresh"/>
Default Gateway	192.168.2.1
DNS	192.168.2.1 8.8.8.8
DHCP Server	192.168.2.1

Wired LAN Port Settings	
Wired LAN Port	Status
LAN1	Connected (100 Mbps Full-Duplex)

Wireless 2.4GHz	
Status	Enabled
MAC Address	00:03:7F:BA:DB:AD
Channel	Ch 9 (Auto)
Transmit Power	100%
RSSI	0

Wireless 2.4GHz /SSID

## IV. *Basic Settings*

---

In our recommendation, please check each of the settings that listed below before using the AP.

- LAN IP Address
- 2.4GHz & 5GHz SSID & Security
- Administrator Name & Password
- Time & Date



**Please note that whenever a new setting is applied to the AP, the webpage will reload, as shown below:**

Configuration is complete. Reloading now...

Please wait for  seconds.

Please follow the instructions below for the basic settings.

## IV-1. Changing IP Address

1. Go to “Network Settings” and tap “LAN-side IP Address”.

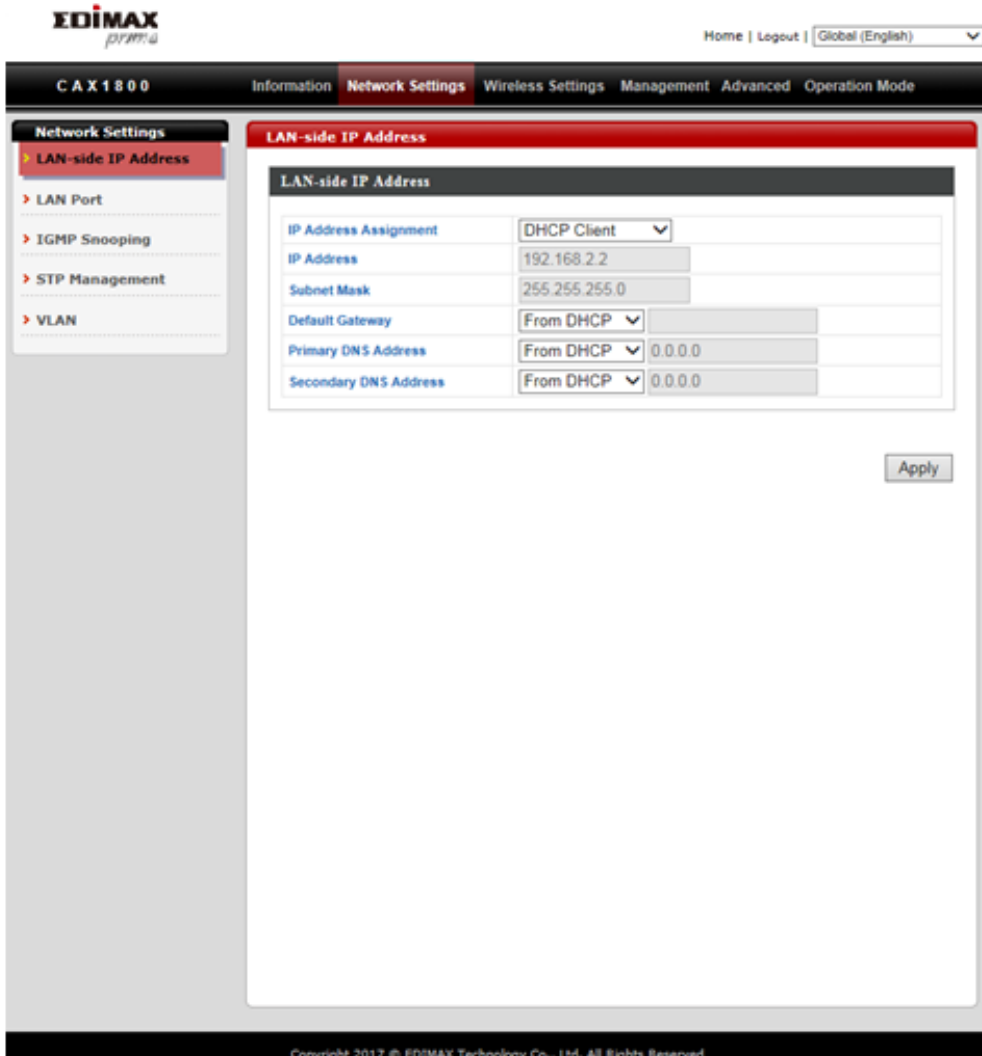

The screenshot shows the EDIMAX CAX1800 web interface. The top navigation bar includes "Home | Logout | Global (English)". The main menu has "Information", "Network Settings", "Wireless Settings", "Management", "Advanced", and "Operation Mode". The "Network Settings" section is expanded, showing "LAN-side IP Address", "LAN Port", "IGMP Snooping", "STP Management", and "VLAN". The "LAN-side IP Address" configuration page is displayed, featuring a table with the following fields:

LAN-side IP Address	
IP Address Assignment	DHCP Client
IP Address	192.168.2.2
Subnet Mask	255.255.255.0
Default Gateway	From DHCP
Primary DNS Address	From DHCP
Secondary DNS Address	From DHCP

An "Apply" button is located at the bottom right of the configuration area. The footer of the page reads "Copyright 2017 © EDIMAX Technology Co., Ltd. All Rights Reserved".

2. Enter the IP address settings you wish to use for your AP. You can use a dynamic (DHCP) or static IP address, depending on your network environment. Click “Apply” to save the changes and wait a few moments for the AP to reload.



**When you change your AP’s IP address, you need to use the new IP address to access the browser based configuration interface instead of the default IP 192.168.2.2.**

## IV-2. Changing SSID For 2.4GHz Wireless Network

1. Go to “Wireless Settings”.
2. Tap “2.4GHz 11bgn”.
3. Tap “Basic”.
4. Enter the new SSID for your 2.4GHz wireless network in the “SSID1” field and click “Apply”.

The screenshot shows the EDIMAX prime CAX1800 wireless settings page. The 'Basic' tab is selected under the '2.4GHz 11bgn' section. The 'SSID1' field is highlighted with a red box and contains the text 'CAX1800-BADBAD\_G'. Other settings include 'Wireless' (Enabled), 'Band' (dropdown), 'Enable SSID number' (1), 'Auto Channel' (Enabled), 'Auto Channel Range' (Ch 1 - 11), 'Auto Channel Interval' (One day), 'Channel Bandwidth' (20 MHz), and 'BSS BasicRateSet' (1,2,5,5,11 Mbps). The 'Apply' and 'Cancel' buttons are visible at the bottom right.



**To utilize multiple 2.4GHz SSIDs, open the drop down menu labelled “Enable SSID number” and select how many SSIDs you require. Then enter a new SSID in the corresponding numbered fields below, before clicking “Apply”.**

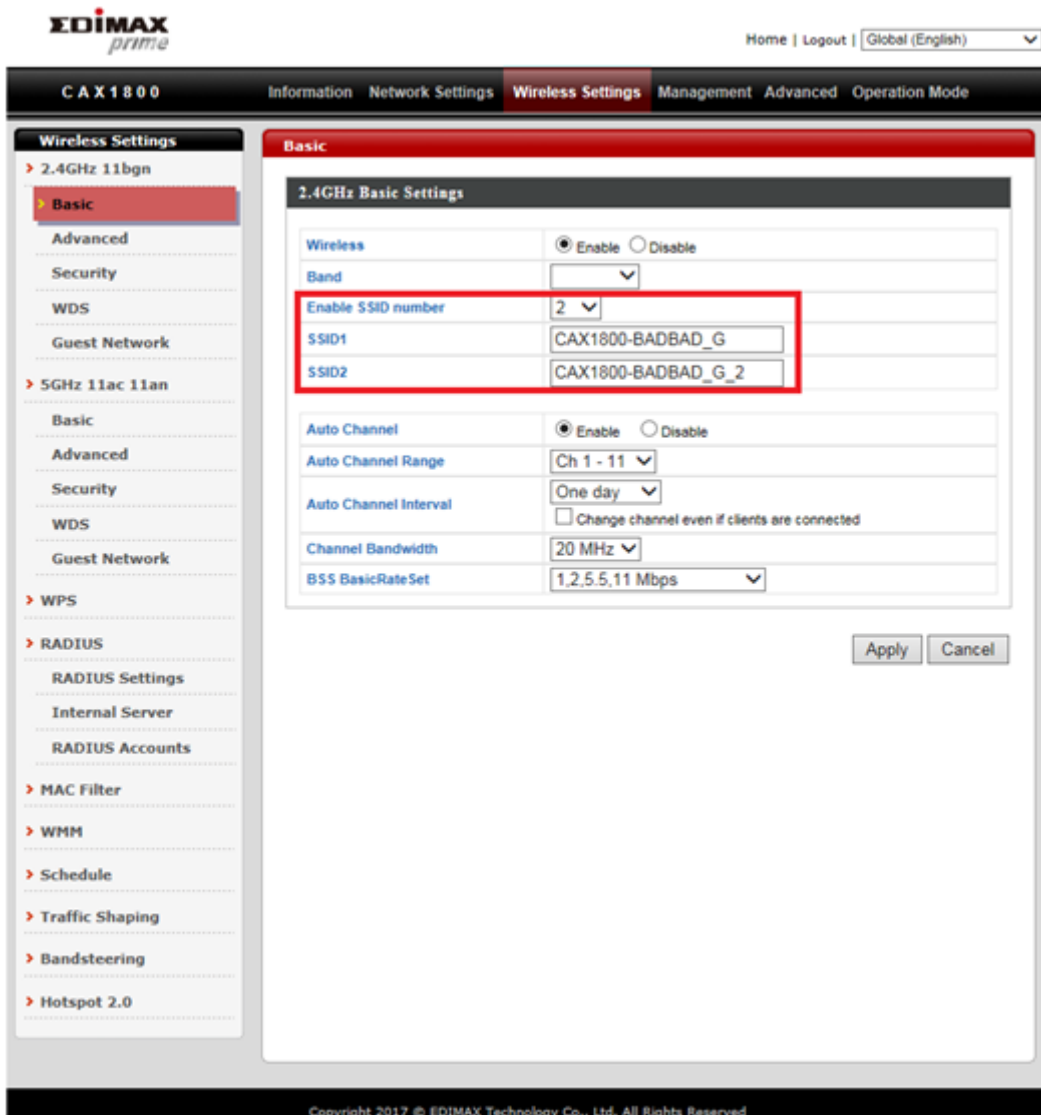

### IV-3. Configuring Security Settings of 2.4GHz wireless network

1. Go to “Wireless Settings”.
2. Tap “2.4GHz 11bgn”.
3. Tap “Security”.
4. Select an “Authentication Method”, enter or select fields where appropriate, and click “Apply”.

EDIMAX  
prime

Home | Logout | Global (English) ▼

CAX1800 Information Network Settings **Wireless Settings** Management Advanced Operation Mode

**Wireless Settings**

- > 2.4GHz 11bgn
  - Basic
  - Advanced
  - Security**
  - WDS
  - Guest Network
- > 5GHz 11ac 11an
  - Basic
  - Advanced
  - Security
  - WDS
  - Guest Network
- > WPS
- > RADIUS
  - RADIUS Settings
  - Internal Server
  - RADIUS Accounts
- > MAC Filter
- > WMM
- > Schedule
- > Traffic Shaping
- > Bandsteering
- > Hotspot 2.0

**Security**

**2.4GHz Wireless Security Settings**

SSID	CAX1800-BADBAD_G ▼
Broadcast SSID	Enable ▼
Wireless Client Isolation	Disable ▼
802.11k	Disable ▼
802.11w	Disable ▼
Load Balancing	100 /100
Authentication Method	No Authentication ▼
Additional Authentication	No additional authentication ▼

**2.4GHz Wireless Advanced Settings**

Smart Handover Settings

Smart Handover	<input type="radio"/> Enable <input checked="" type="radio"/> Disable
RSSI Threshold	-80 ▼ dB

Apply Cancel

Copyright 2017 © EDIMAX Technology Co., Ltd. All Rights Reserved



If multiple SSIDs are used, specify which SSID to configure using the “SSID” drop down menu.

The screenshot displays the EDIMAX prime web interface for configuring wireless settings. The top navigation bar includes 'Home | Logout | Global (English)'. The main menu shows 'CAX1800' and 'Wireless Settings' selected. The left sidebar lists various settings, with 'Security' under '2.4GHz 11bgn' highlighted. The main content area shows the 'Security' configuration for the 2.4GHz network. The '2.4GHz Wireless Security Settings' section includes fields for SSID (CAX1800-BADBAD\_G), Broadcast SSID (Enable), Wireless Client Isolation (Disable), 802.11k (Disable), 802.11w (Disable), Load Balancing (100/100), Authentication Method (No Authentication), and Additional Authentication (No additional authentication). The '2.4GHz Wireless Advanced Settings' section includes Smart Handover Settings (Smart Handover: Disable, RSSI Threshold: -80 dB) and 'Apply' and 'Cancel' buttons. The SSID field is highlighted with a red box.

#### IV-4. Changing Security Setting for 5GHz wireless network

Follow the steps outlined in “Changing SSID for 2.4GHz wireless network” and “Configuring Security Setting for 2.4GHz wireless network” but choose the 5GHz option instead.

## IV-5. Changing Admin Name and Password

1. Go to “Management”.
2. Tap “Admin”.
3. Complete the “Administrator Name” and “Administrator Password” fields and click “Apply”.

## IV-6. Changing Date and Time

1. Go to “Management”.
2. Tap “Date and Time”.

The screenshot displays the EDIMAX CAX1800 web management interface. The top navigation bar includes 'Home | Logout | Global (English)'. The main menu on the left lists 'Management' options: Admin, Date and Time (selected), Syslog Server, Ping Test, Traceroute Test, and I'm Here. The central content area is titled 'Date and Time' and is divided into three sections:

- Date and Time Settings:** This section is highlighted with a red border. It contains a 'Local Time' section with dropdown menus for Year (2012), Month (Jan), and Day (1), and input fields for Hours (0), Minutes (00), and Seconds (00). Below these is a button labeled 'Acquire Current Time from Your PC'.
- NTP Time Server:** This section includes a 'Use NTP' checkbox (disabled), an 'Auto Daylight Saving' checkbox (checked/enabled), a 'Server Name' dropdown menu (set to 'User-Defined'), and an 'Update Interval' of 24 (Hours).
- Time Zone:** This section features a 'Time Zone' dropdown menu set to '(GMT) Greenwich Mean Time: Dublin, Edinburgh, Lisbon, London'.

At the bottom right of the settings area, there are 'Apply' and 'Cancel' buttons. The footer of the page reads 'Copyright 2017 © EDIMAX Technology Co., Ltd. All Rights Reserved'.

- Set the correct time and time zone for your AP using the drop down menus. The AP also supports NTP (Network Time Protocol). Alternatively, you can enter the host name or IP address of a time server. Click “Apply” when you are finished.

 **You can use the “Acquire Current Time from Your PC” button if you wish to set the AP to the same time as your PC.**

Congrats! The basic settings of your AP are now configured and your AP is up and running!

## V. CAX1800 Settings

The CAX1800 features a range of advanced functions. Please open a browser and enter the CAX1800 default IP address “192.168.2.2” to access the AP configuration webpage.

### V-1. Information

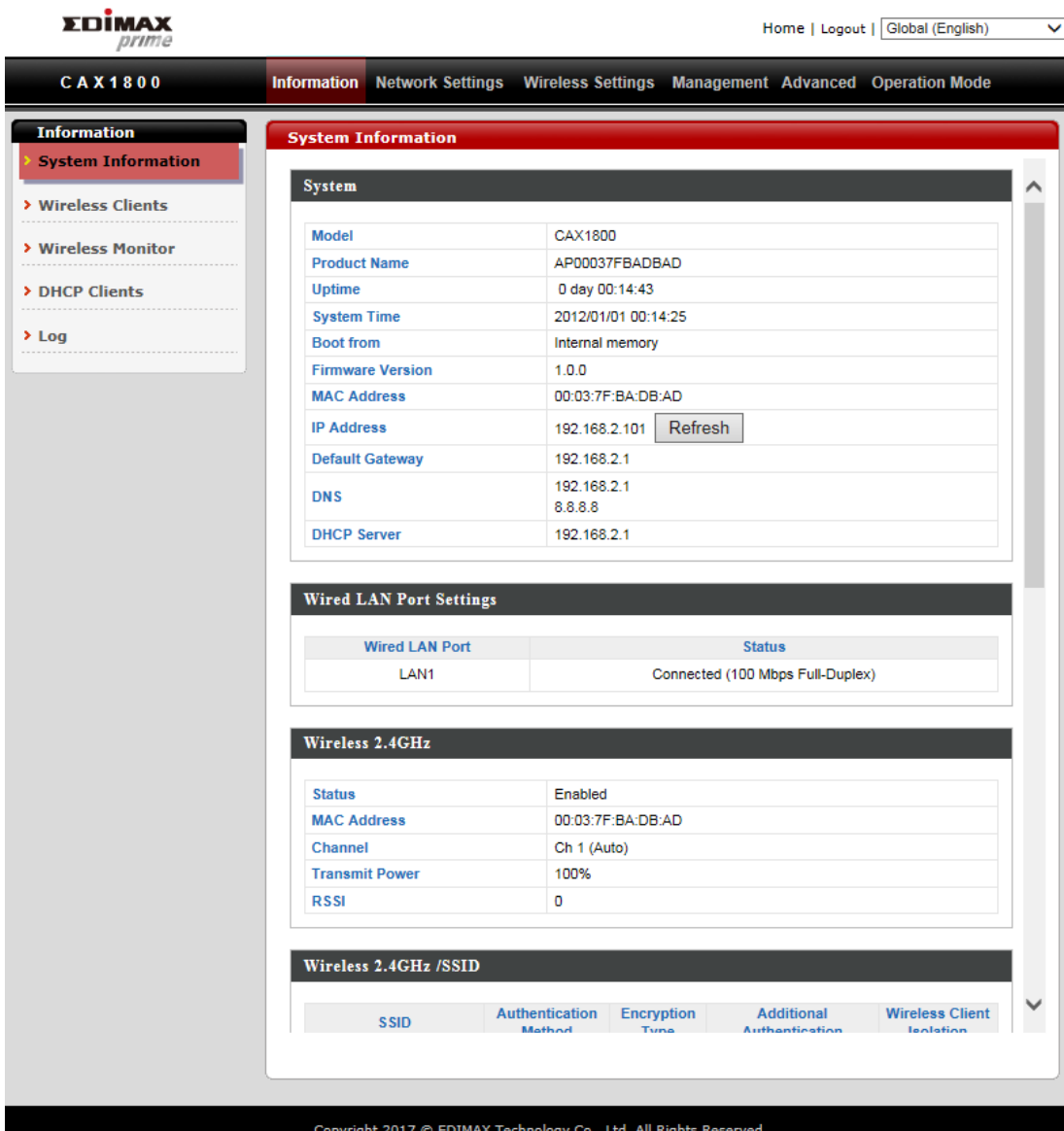

The screenshot displays the EDIMAX CAX1800 configuration interface. The top navigation bar includes 'Home | Logout | Global (English)'. The main menu shows 'CAX1800' and various settings categories: Information, Network Settings, Wireless Settings, Management, Advanced, and Operation Mode. The 'Information' section is expanded, showing a sidebar with 'System Information', 'Wireless Clients', 'Wireless Monitor', 'DHCP Clients', and 'Log'. The main content area is titled 'System Information' and contains several sections:

- System Information Table:**

Model	CAX1800
Product Name	AP00037FBADBAD
Uptime	0 day 00:14:43
System Time	2012/01/01 00:14:25
Boot from	Internal memory
Firmware Version	1.0.0
MAC Address	00:03:7F:BA:DB:AD
IP Address	192.168.2.101 <input type="button" value="Refresh"/>
Default Gateway	192.168.2.1
DNS	192.168.2.1 8.8.8.8
DHCP Server	192.168.2.1
- Wired LAN Port Settings Table:**

Wired LAN Port	Status
LAN1	Connected (100 Mbps Full-Duplex)
- Wireless 2.4GHz Table:**

Status	Enabled
MAC Address	00:03:7F:BA:DB:AD
Channel	Ch 1 (Auto)
Transmit Power	100%
RSSI	0
- Wireless 2.4GHz /SSID Table:**

SSID	Authentication Method	Encryption Type	Additional Authentication	Wireless Client Isolation

Copyright 2017 © EDIMAX Technology Co., Ltd. All Rights Reserved

## i. System Information

“System Information” page displays basic system information.

**Information**

- > **System Information**
- > Wireless Clients
- > Wireless Monitor
- > DHCP Clients
- > Log

### System Information

#### System

Model	CAX1800
Product Name	AP00037FBADB
Uptime	0 day 02:11:28
System Time	2012/01/01 02:11:09
Boot from	Internal memory
Firmware Version	0.1.0
MAC Address	00:03:7F:BA:DB:AD
IP Address	192.168.2.101 <input type="button" value="Refresh"/>
Default Gateway	192.168.2.1
DNS	192.168.2.1 8.8.8.8
DHCP Server	192.168.2.1

#### Wired LAN Port Settings

Wired LAN Port	Status
LAN1	Connected (100 Mbps Full-Duplex)

#### Wireless 2.4GHz

Status	Enabled
MAC Address	00:03:7F:BA:DB:AD
Channel	Ch 3 (Auto)
Transmit Power	100%
RSSI	0

#### Wireless 2.4GHz /SSID

SSID	Authentication Method	Encryption Type	Additional Authentication	Wireless Client Isolation
------	-----------------------	-----------------	---------------------------	---------------------------

<b>System</b>	
<b>Model</b>	Displays the model number of the AP.
<b>Product Name</b>	Displays the product name for reference, which consists of “AP” plus the MAC address.
<b>Uptime</b>	Displays the total time since the device was turned on.
<b>System Time</b>	Displays the system time.
<b>Boot From</b>	Displays information for the booted hardware, booted from internal memory.
<b>Firmware Version</b>	Displays the firmware version.
<b>MAC Address</b>	Displays the AP’s MAC address.
<b>Management VLAN ID</b>	Displays the management VLAN ID.
<b>IP Address</b>	Displays the IP address of this device. <b>(Click “Refresh” to update this value)</b>
<b>Default Gateway</b>	Displays the IP address of the default gateway.
<b>DNS</b>	IP address of DNS <b>(Domain Name Server)</b>
<b>DHCP Server</b>	IP address of DHCP Server.

<b>Wired LAN Port Settings</b>	
<b>Wired LAN Port</b>	Specifies which LAN port.
<b>Status</b>	Displays the status of the specified LAN port. <b>(Connected or disconnected)</b>
<b>VLAN Mode/ID</b>	Displays the VLAN mode (tagged or untagged) and VLAN ID for the specified LAN port.

<b>Wireless 2.4GHz (5GHz)</b>	
<b>Status</b>	Displays the status of the 2.4GHz or 5GHz wireless. (Enabled or disabled)
<b>MAC Address</b>	Displays the AP MAC address.
<b>Channel</b>	Displays the channel number the specified wireless frequency is using for broadcast.
<b>Transmit Power</b>	Displays the wireless radio transmit power level as a percentage.
<b>RSSI</b>	Received Signal Strength Indicator (RSSI) is a measurement of the power present in a received radio signal.

<b>Wireless 2.4GHZ (5GHz) / SSID</b>	
<b>SSID</b>	Displays the SSID name(s) for the specified frequency.
<b>Authentication Method</b>	Displays the authentication method for the specified SSID.
<b>Encryption Type</b>	Displays the encryption type for the specified SSID.
<b>VLAN ID</b>	Displays the VLAN ID for the specified SSID.
<b>Additional Authentication</b>	Displays the additional authentication type for the specified SSID.
<b>Wireless Client Isolation</b>	Displays whether wireless client isolation is in use for the specified SSID.

<b>Wireless 2.4GHZ (5GHz) / WDS Status</b>	
<b>MAC Address</b>	Displays the peer AP MAC address.
<b>Encryption Type</b>	Displays the encryption type for the specified WDS.
<b>VLAN Mode/ID</b>	Displays the VLAN ID for the specified WDS.

## ii. Wireless Clients

“Wireless Clients” page displays information about all wireless clients connected to the device on the 2.4GHz or 5GHz frequency.

### Refresh time

<b>Auto Refresh Time</b>	Select a time interval for the client table list to automatically refresh.
<b>Manual Refresh</b>	Click refresh to manually refresh the client table.

### 2.4GHz (5GHz) WLAN Client Table

<b>SSID</b>	Displays the SSID which the client is connected to.
<b>MAC Address</b>	Displays the MAC address of the client.
<b>Tx</b>	Displays the total data packets transmitted by the specified client.
<b>Rx</b>	Displays the total data packets received by the specified client.
<b>Signal (%)</b>	Displays the wireless signal strength for the specified client.
<b>Connected Time</b>	Displays the total time the wireless client has been connected to the AP.
<b>Idle Time</b>	Client idle time is the time for which the client has not transmitted any data packets.
<b>Vendor</b>	The vendor of the client’s wireless adapter is displayed here.

### iii. Wireless Monitor

“Wireless Monitor” is a tool built into the device to scan and monitor the surrounding wireless environment. Select a frequency and click “Scan” to display a list of all SSIDs within range along with relevant details for each SSID.

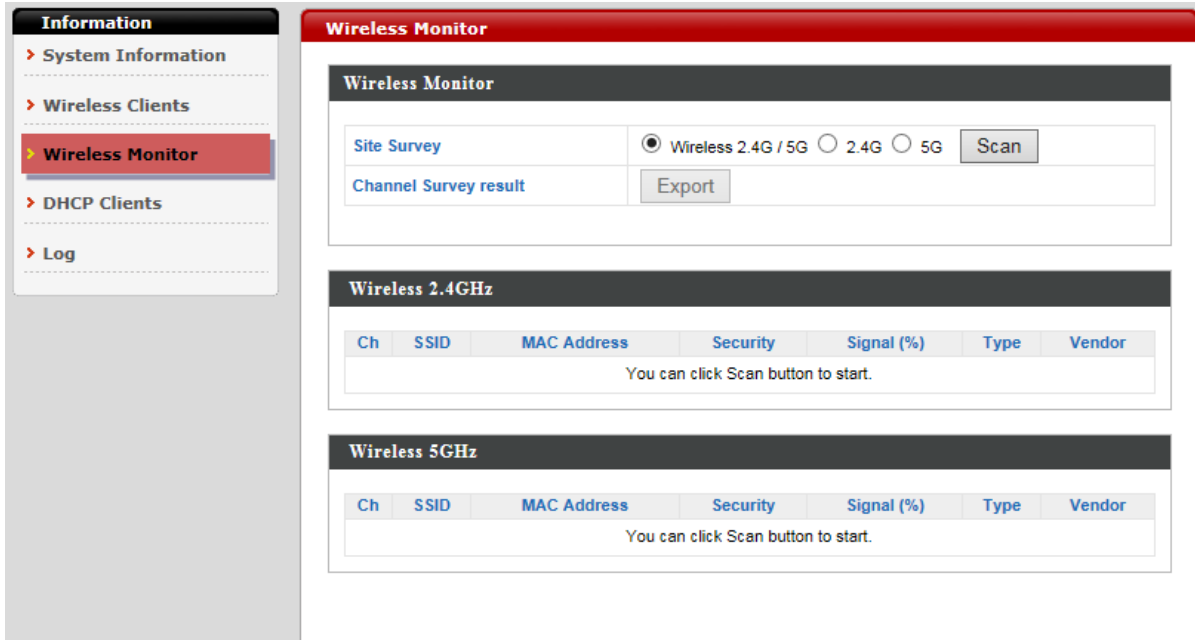

Wireless Monitor	
<b>Site Survey</b>	Select which frequency (or both) to scan, and click “Scan” to begin.
<b>Channel Survey Result</b>	After a scan is complete, click “Export” to save the results to local storage.

Site Survey Results	
<b>Ch</b>	Displays the channel number used by the specified SSID.
<b>SSID</b>	Displays the SSID identified by the scan.
<b>MAC Address</b>	Displays the MAC address of the wireless router/AP for the specified SSID.
<b>Security</b>	Displays the authentication/encryption type of the specified SSID.
<b>Signal (%)</b>	Displays the current signal strength of the SSID.
<b>Type</b>	Displays the 802.11 wireless networking standard(s) of the specified SSID.
<b>Vendor</b>	Displays the vendor of the wireless router/AP for the specified SSID.

## iv. DHCP Clients

“DHCP Clients” shows information of DHCP leased clients.

The screenshot shows a web interface with a sidebar on the left containing a menu with items: Information, System Information, Wireless Clients, Wireless Monitor, DHCP Clients (highlighted), and Log. The main content area has a red header 'DHCP Clients' and a text block stating: 'This table shows the assigned IP address, MAC address and expiration time for each DHCP leased client.' Below this is a table titled 'DHCP Client Table' which is currently empty. A 'Refresh' button is located below the table.

## v. Log

“System log” displays system operation information such as up time and connection processes. This information is useful for administrators.

The screenshot shows a web interface with a sidebar on the left containing a menu with items: Information, System Information, Wireless Clients, Wireless Monitor, DHCP Clients, and Log (highlighted). The main content area has a red header 'Log' and a section titled 'All Events/Activities'. It includes a search box and a checkbox for 'Match whole words'. Below is a table with the following data:

ID	Date and Time	Category	Severity	Users	Events/Activities
59	2012/01/01 00:00:51	SYSTEM	Low	admin	WLAN[5G], Best channel selection start, switch to channel 36 + 40 + 44 + 48
58	2012/01/01 00:00:42	SYSTEM	Low	admin	LAN, Port[0] link is changed to 100Mbps-Full-Duplex
57	2012/01/01 00:00:42	SYSTEM	Low	admin	WLAN[2.4G], Best channel selection start, switch to channel 3
56	2012/01/01 00:00:41	WLAN	Low	admin	ath16: IEEE 802.11 driver had channel switch: freq=5240, ht=1, offset=-1, width=3 (80 MHz), cf1=5210, cf2=0
55	2012/01/01 00:00:41	SYSTEM	Low	admin	Bandsteering, Stopping
54	2012/01/01 00:00:32	WLAN	Low	admin	ath0: IEEE 802.11 driver had channel switch: freq=2422, ht=1, offset=0, width=1 (20 MHz), cf1=2422, cf2=0
53	2012/01/01 00:00:32	SYSTEM	Low	admin	Bandsteering, Stopping
52	2012/01/01 00:00:29	SYSTEM	Low	admin	LAN, Port[0] link status is changed to down



**Older entries will be overwritten when the log is full.**

The following information/events are recorded by the log:

<b>Log (Category)</b>	
<b>USB</b>	Mount & un-mount
<b>Wireless Client</b>	Connected & disconnected Key exchange success & fail
<b>Authentication</b>	Authentication fail or successful
<b>Association</b>	Success or fail
<b>WPS</b>	M1 - M8 messages WPS success
<b>Change Settings</b>	Displays the total time the wireless client has been connected to the AP
<b>System Boot</b>	Displays current model name
<b>Vendor</b>	The vendor of the client's wireless adapter is displayed here
<b>NTP Client</b>	Syncing time with NTP server
<b>Wired Link</b>	LAN Port link status and speed status
<b>Proxy ARP</b>	Proxy ARP module start & stop
<b>Bridge</b>	Bridge start & stop
<b>SNMP</b>	SNMP server start & stop
<b>HTTP</b>	HTTP start & stop
<b>HTTPS</b>	HTTPS start & stop
<b>SSH</b>	SSH-client server start & stop
<b>Telnet</b>	Telnet-client server start or stop
<b>WLAN (2.4G) and (5G)</b>	WLAN (2.4G) and (5G) channel status and country/region status

## V-2. Network Settings

The screenshot shows the EDIMAX prime web interface for a CA X1800 device. The top navigation bar includes 'Home | Logout | Global (English)'. The main menu has 'Information', 'Network Settings', 'Wireless Settings', 'Management', 'Advanced', and 'Operation Mode'. The left sidebar shows 'Network Settings' with sub-items: 'LAN-side IP Address', 'LAN Port', 'IGMP Snooping', 'STP Management', and 'VLAN'. The main content area is titled 'LAN-side IP Address' and contains a table of configuration fields:

LAN-side IP Address	
IP Address Assignment	DHCP Client
IP Address	192.168.2.2
Subnet Mask	255.255.255.0
Default Gateway	From DHCP
Primary DNS Address	From DHCP
Secondary DNS Address	From DHCP

An 'Apply' button is located at the bottom right of the configuration area. The footer contains the text: 'Copyright 2017 © EDIMAX Technology Co., Ltd. All Rights Reserved'.

### i. LAN-side IP Address

“LAN-side IP address” allows users to configure your AP on your LAN. You can enable the AP to dynamically receive an IP address from your router’s DHCP server or you can specify a static IP address for your AP, as well as configure DNS servers.

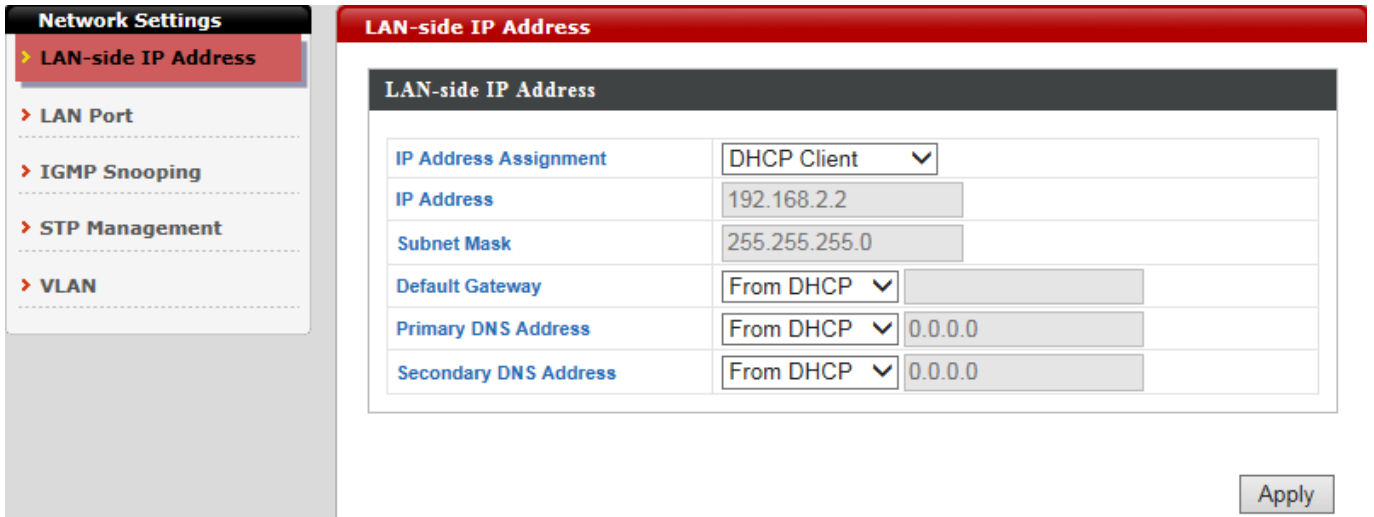

LAN-side IP Address	
<b>IP Address Assignment</b>	<p>Select “DHCP Client” for your AP to be assigned a dynamic IP address from your router’s DHCP server.</p> <p>Select “Static IP” to manually specify a static/fixed IP address for your AP.</p> <p>Select “DHCP Server” for your AP to assign a dynamic IP address to your PC. You will have to set a Primary DNS address and a Secondary DNS address. For example, Google’s Primary DNS address is 8.8.4.4 and Secondary DNS address is 8.8.8.8.</p> <div style="text-align: center;"> </div>
<b>IP Address</b>	Specify the IP address here. This IP address will be assigned to your AP and will replace the default IP address.
<b>Subnet Mask</b>	Specify a subnet mask. The default value is 255.255.255.0
<b>Default Gateway</b>	<p>For DHCP users, select “From DHCP” to get default gateway from your DHCP server or “User-Defined” to enter a gateway manually. For static IP users, the default value is blank.</p> <div style="text-align: center;"> </div>

<b>Primary DNS Address</b>	<p>DHCP users can select “From DHCP” to get primary DNS server’s IP address from DHCP or “User-Defined” to manually enter a value. For static IP users, the default value is blank.</p> <div data-bbox="807 322 1066 456"> <input type="text" value="From DHCP"/> <input type="text" value="User-Defined"/> <input type="text" value="From DHCP"/> </div>
<b>Secondary DNS Address</b>	<p>Users can manually enter a value when DNS server’s primary address is set to “User-Defined”.</p> <div data-bbox="807 562 1066 696"> <input type="text" value="From DHCP"/> <input type="text" value="User-Defined"/> <input type="text" value="From DHCP"/> </div>

**NOTE: DHCP users can select to get DNS servers’ IP address from DHCP or manually enter a value. For static IP users, the default value is blank.**

## ii. LAN Port

“LAN Port” allows users to configure the settings for LAN port.

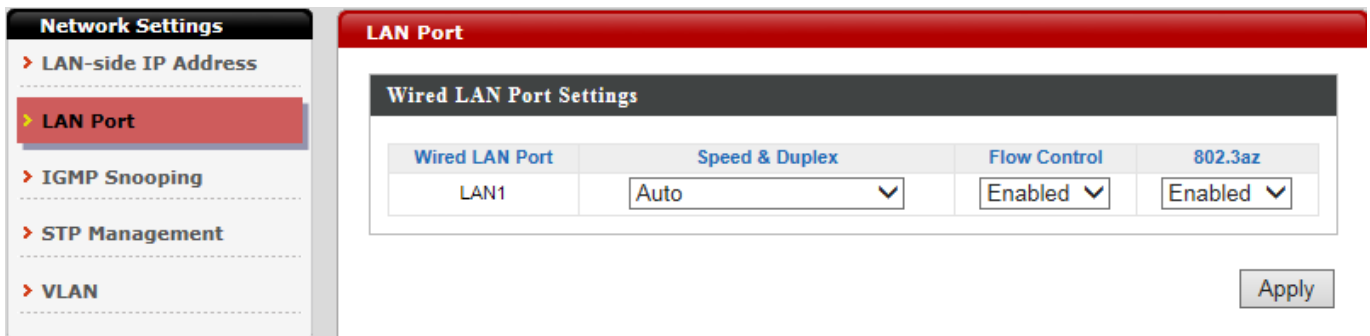

<b>Wired LAN Port</b>	Identifies LAN port 1.
<b>Enable</b>	Enable/disable specified LAN port.
<b>Speed &amp; Duplex</b>	Select a speed & duplex type for specified LAN port, or use the “Auto” value. LAN ports can operate up to 1000Mbps and full-duplex enables simultaneous data packets transfer/receive. <div style="border: 1px solid black; padding: 5px; margin: 10px auto; width: fit-content;"> <p>Auto ▼</p> <p>Auto</p> <p>10 Mbps Half-Duplex</p> <p>10 Mbps Full-Duplex</p> <p>100 Mbps Half-Duplex</p> <p>100 Mbps Full-Duplex</p> <p>1000 Mbps Full-Duplex</p> </div>
<b>Flow Control</b>	Enable/disable flow control. Flow control can pause new session request until current data processing is complete, in order to avoid device overloads under heavy traffic.
<b>802.3az</b>	Enable/disable 802.3az. 802.3az. 802.3az is an energy efficient Ethernet feature which disables unused interfaces to reduce power usage.

### iii. IGMP Snooping

IGMP snooping is the process of listening to Internet Group Management Protocol (IGMP) network traffic. The feature allows a network switch to listen in on the IGMP conversation between hosts and routers. By listening to these conversations the switch maintains a map of which links need which IP multicast streams.

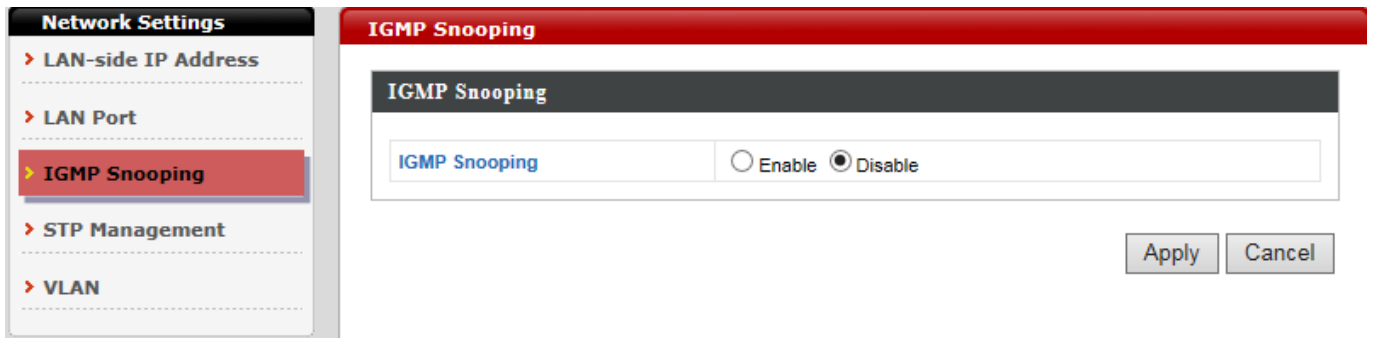

### iv. STP Management

When enabled, STP ensures that you do not create loops when you have redundant paths in your network.

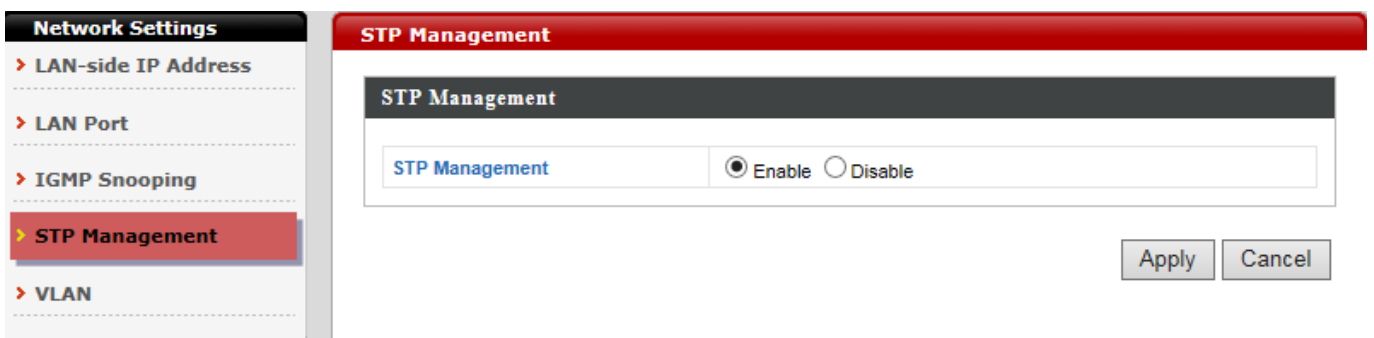

## v. VLAN

VLAN is a local area network which maps workstations virtually instead of physically and allows you to group together or isolate users from each other.

VID	VLAN Name	Untag VLAN Ports	Tag VLAN Ports	Edit	Delete
1	default	Mgmt, LAN, S-1(2.4G), S-2(2.4G), S-3(2.4G), S-4(2.4G), S-5(2.4G), S-6(2.4G), S-7(2.4G), S-8(2.4G), S-9(2.4G), S-10(2.4G), S-11(2.4G), S-12(2.4G), S-13(2.4G), S-14(2.4G), S-15(2.4G), S-16(2.4G), W-1(2.4G), S-1(5G), S-2(5G), S-3(5G), S-4(5G), S-5(5G), S-6(5G), S-7(5G), S-8(5G), S-9(5G), S-10(5G), S-11(5G), S-12(5G), S-13(5G), S-14(5G), S-15(5G), S-16(5G), W-1(5G)		Edit	Delete
2	temp	S-2(2.4G), S-4(2.4G), S-5(2.4G), S-6(2.4G), S-7(2.4G), S-8(2.4G), S-9(2.4G), S-10(2.4G), S-11(2.4G), S-12(2.4G), S-13(2.4G), S-14(2.4G), S-15(2.4G), S-16(2.4G), W-1(2.4G), S-1(5G), S-2(5G), S-3(5G), S-4(5G), S-5(5G), S-6(5G), S-7(5G), S-8(5G), S-9(5G), S-10(5G), S-11(5G), S-12(5G), S-13(5G), S-14(5G), S-15(5G), S-16(5G), W-1(5G)	Mgmt, LAN	Edit	Delete

VLAN Interface	
<b>Wired LAN Port/Wireless</b>	Identifies LAN port 1 and wireless SSIDs.
<b>VLAN Mode</b>	Select “Tagged Port” or “Untagged Port” for specified LAN interface.
<b>VLAN ID</b>	Set a VLAN ID for specified interface, if “Untagged Port” is selected.

Management VLAN	
<b>VLAN ID</b>	Specify the VLAN ID of the management VLAN. Only the hosts belonging to the same VLAN can manage the device.

**NOTE: VLAN IDs in the range 1 – 4095 are supported.**

## V-3. Wireless Settings

**EDIMAX**  
*prime*

Home | Logout | Global (English) ▼

C A X 1 8 0 0    Information   Network Settings   **Wireless Settings**   Management   Advanced   Operation Mode

**Wireless Settings**

- > 2.4GHz 11bgn
  - Basic**
  - Advanced
  - Security
  - WDS
  - Guest Network
- > 5GHz 11ac 11an
  - Basic
  - Advanced
  - Security
  - WDS
  - Guest Network
- > WPS
- > RADIUS
  - RADIUS Settings
  - Internal Server
  - RADIUS Accounts
- > MAC Filter
- > WMM
- > Schedule
- > Traffic Shaping
- > Bandsteering

**Basic**

**2.4GHz Basic Settings**

Wireless	<input checked="" type="radio"/> Enable <input type="radio"/> Disable
Band	11b/g/n/ax ▼
Enable SSID number	1 ▼
SSID1	CAX1800-CCDD10_G
Auto Channel	<input checked="" type="radio"/> Enable <input type="radio"/> Disable
Auto Channel Range	Ch 1 - 11 ▼
Auto Channel Interval	One day ▼ <input type="checkbox"/> Change channel even if clients are connected
Channel Bandwidth	Auto ▼
BSS BasicRateSet	1,2,5.5,11 Mbps ▼

Apply   Cancel

Copyright 2017 © EDIMAX Technology Co., Ltd. All Rights Reserved

## i. Basic (2.4GHz 11bgn)

You can set up basic settings for AP 2.4GHz Wi-Fi network.

The screenshot displays the EDIMAX prime web interface for the CAX1800 device. The top navigation bar includes 'Home | Logout | Global (English)'. The main menu shows 'Information', 'Network Settings', 'Wireless Settings' (selected), 'Management', 'Advanced', and 'Operation Mode'. The left sidebar lists various settings categories, with '2.4GHz 11bgn' expanded to show 'Basic' (selected), 'Advanced', 'Security', 'WDS', and 'Guest Network'. The main content area is titled 'Basic' and contains the '2.4GHz Basic Settings' configuration table.

2.4GHz Basic Settings	
Wireless	<input checked="" type="radio"/> Enable <input type="radio"/> Disable
Band	11b/g/n/ax
Enable SSID number	1
SSID1	CAX1800-CCDD10_G
Auto Channel	<input checked="" type="radio"/> Enable <input type="radio"/> Disable
Auto Channel Range	Ch 1 - 11
Auto Channel Interval	One day <input type="checkbox"/> Change channel even if clients are connected
Channel Bandwidth	Auto
BSS BasicRateSet	1,2,5.5,11 Mbps

Buttons: Apply, Cancel

Copyright 2017 © EDIMAX Technology Co., Ltd. All Rights Reserved

<b>Wireless</b>	Enable or disable the AP 2.4GHz wireless radio. When disabled, no 2.4GHz SSIDs will be active.						
<b>Band</b>	Wireless standard used for the AP. Combinations of 802.11b, 802.11g & 802.11n can be selected.						
<b>Enable SSID Number</b>	<div style="background-color: #333; color: #fff; padding: 2px;"><b>2.4GHz Basic Settings</b></div> <table border="1" style="width: 100%; border-collapse: collapse; margin-top: 5px;"> <tr> <td style="padding: 2px;"><b>Wireless</b></td> <td style="padding: 2px;"><input checked="" type="radio"/> Enable <input type="radio"/> Disable</td> </tr> <tr> <td style="padding: 2px;"><b>Band</b></td> <td style="padding: 2px;">11b/g/n/ax ▼</td> </tr> <tr> <td style="padding: 2px;"><b>Enable SSID number</b></td> <td style="padding: 2px;">16 ▼</td> </tr> </table> <p>Select how many SSIDs to enable for the 2.4GHz frequency from the drop down menu. (A maximum of 16 can be enabled)</p>	<b>Wireless</b>	<input checked="" type="radio"/> Enable <input type="radio"/> Disable	<b>Band</b>	11b/g/n/ax ▼	<b>Enable SSID number</b>	16 ▼
<b>Wireless</b>	<input checked="" type="radio"/> Enable <input type="radio"/> Disable						
<b>Band</b>	11b/g/n/ax ▼						
<b>Enable SSID number</b>	16 ▼						
<b>SSID#</b>	Enter the SSID name for the specified SSID (up to 16). The SSID can consist of any combination of up to 32 alphanumeric characters.						
<b>VLAN ID</b>	Specify a VLAN ID for each SSID.						
<b>Auto Channel</b>	Enable/disable auto channel selection. Enable: Auto channel selection will automatically set the wireless channel for the AP2.4GHz frequency based on availability and potential interference. Disable: Select a channel manually as shown in the next table.						
<b>Auto Channel Range</b>	Select a range to which auto channel selection can choose from.						
<b>Auto Channel Interval</b>	Select a time interval for how often the auto channel setting will check/reassign the wireless channel. Check/uncheck the “Change channel even if clients are connected” box according to your preference.						
<b>Channel Bandwidth</b>	Select the channel bandwidth: - 20MHz (lower performance but less interference). - 40MHz (higher performance but potentially higher interference). - Auto (automatically select based on interference level).						
<b>BSS BasicRateSet</b>	This is a series of rates to control communication frames for wireless clients.						

When auto channel is disabled, configurable fields will change. Select a wireless channel manually:

<b>Auto Channel</b>	<input checked="" type="radio"/> Enable <input type="radio"/> Disable
<b>Auto Channel Range</b>	Ch 1 - 11 ▾
<b>Auto Channel Interval</b>	One day ▾ <input type="checkbox"/> Change channel even if clients are connected
<b>Channel Bandwidth</b>	Auto ▾
<b>BSS BasicRateSet</b>	all ▾



<b>Auto Channel</b>	<input type="radio"/> Enable <input checked="" type="radio"/> Disable
<b>Channel</b>	Ch 11, 2462MHz ▾
<b>Channel Bandwidth</b>	Auto, +Ch 7 ▾
<b>BSS BasicRateSet</b>	all ▾

<b>Channel</b>	Select a wireless channel from 1 – 11.
<b>Channel Bandwidth</b>	Set the channel bandwidth: <ul style="list-style-type: none"> <li>- 20MHz (lower performance but less interference).</li> <li>- 40MHz (higher performance but potentially higher interference)</li> <li>- Auto (automatically select based on interference level).</li> </ul>
<b>BSS BasicRateSet</b>	This is a series of rates to control communication frames for wireless clients.

## ii. Advanced (2.4GHz 11bgn)

In our recommendations, these settings are for experienced users only. Please do not change any of the values on this page unless you are already familiar with these functions.



**Changing these settings can adversely affect the performance of your AP.**

The screenshot shows the EDIMAX prime CAX1800 web interface. The top navigation bar includes 'Home | Logout | Global (English)'. The main menu has 'Wireless Settings' selected. The left sidebar shows '2.4GHz 11bgn' expanded with 'Advanced' selected. The main content area is titled 'Advanced' and contains '2.4GHz Advanced Settings' with the following configuration table:

2.4GHz Advanced Settings	
Contention Slot	Short
Preamble Type	Short
Guard Interval	Short GI
802.11g Protection	<input checked="" type="radio"/> Enable <input type="radio"/> Disable
802.11n Protection	<input checked="" type="radio"/> Enable <input type="radio"/> Disable
DTIM Period	1 (1-255)
RTS Threshold	2347 (1-2347)
Fragment Threshold	2346 (256-2346)
Multicast Rate	Auto
Tx Power	100%
Beacon Interval	100 (40-1000 ms)
Station Idle Timeout	60 (30-65535 seconds)
Airtime Fairness	Auto <input type="button" value="Edit SSID Rate"/>

Buttons for 'Apply' and 'Cancel' are located at the bottom right of the settings area.

<b>Contention Slot</b>	Select “Short” or “Long” – this value is used for contention windows in WMM.
<b>Preamble Type</b>	Set the wireless radio preamble type. The preamble type in 802.11 based wireless communications defines the length of the CRC (Cyclic Redundancy Check) block for communication between the AP and roaming wireless adapters. (The default value is “Short Preamble”)
<b>Guard Interval</b>	Set the guard interval. A shorter interval can improve performance.
<b>802.11g Protection</b>	Enable/disable 802.11g protection, which increases reliability but reduces bandwidth (clients will send Request to Send (RTS) to AP, and AP will broadcast Clear to Send (CTS), before a packet is sent from client).
<b>802.11n Protection</b>	Enable/disable 802.11n protection, which increases reliability but reduces bandwidth (clients will send Request to Send (RTS) to AP, and AP will broadcast Clear to Send (CTS), before a packet is sent from client).
<b>DTIM Period</b>	Set the DTIM (delivery traffic indication message) period value of the wireless radio. (The default value is 1)
<b>RTS Threshold</b>	Set the RTS threshold of the wireless radio. (The default value is 2347)
<b>Fragment Threshold</b>	Set the fragment threshold of the wireless radio. (The default value is 2346)
<b>Multicast Rate</b>	Set the transfer rate for multicast packets or use the “Auto” setting. The range of the transfer rate is between 1Mbps to 54Mbps
<b>Tx Power</b>	Set the power output of the wireless radio. You may not require 100% output power. Setting a lower power output may enhance security since access to your signal can be potentially prevented from malicious/unknown users in distant areas.
<b>Beacon Interval</b>	Set the beacon interval of the wireless radio. (The default value is 100)
<b>Station idle timeout</b>	Set the interval for the AP to send keepalive messages to a wireless client to check if the station is still alive/active.

## Airtime Fairness

Airtime Fairness gives equal amounts of air time (instead of equal number of frames) to each client regardless of its theoretical data rate.

Set airtime fairness to “Auto”, “Static” or “Disable”.

When “Auto” is selected, the share rate is automatically managed.

When “Static” is selected, press “Edit SSID Rate” to enter a % for each SSID’s share rate as shown below:

**Advanced**

Shared Rate for Airtime Fairness

#	SSID / WDS MAC address	Shared Rate
1	CAX1800-BADBAD_G	<input type="text" value="100"/> %

The % field has to add up to 100% or the system will display a message:



total value should be 100 %.

Airtime fairness is disabled if “Disable” is selected.

### iii. Security (2.4GHz 11bgn)

The AP provides various security options (wireless data encryption). When data is encrypted, information transmitted wirelessly cannot be read by anyone who does not know the correct encryption key.



**It is essential to configure wireless security in order to prevent unauthorised access to your network.**

**EDIMAX prime** Home | Logout | Global (English) ▼

**CAX1800** Information Network Settings **Wireless Settings** Management Advanced Operation Mode

**Wireless Settings**

- > 2.4GHz 11bgn
  - Basic
  - Advanced
  - > Security**
  - WDS
  - Guest Network
- > 5GHz 11ac 11an
  - Basic
  - Advanced
  - Security
  - WDS
  - Guest Network
- > WPS
- > RADIUS
  - RADIUS Settings
  - Internal Server
  - RADIUS Accounts
- > MAC Filter
- > WMM
- > Schedule
- > Traffic Shaping
- > Bandsteering

**Security**

**2.4GHz Wireless Security Settings**

SSID	CAX1800-CCDD10_G ▼
Broadcast SSID	Enable ▼
Wireless Client Isolation	Disable ▼
802.11k	Disable ▼
802.11w	Disable ▼
Load Balancing	100 /100
Authentication Method	No Authentication ▼
Additional Authentication	No additional authentication ▼

**2.4GHz Wireless Advanced Settings**

Smart Handover Settings

Smart Handover	<input type="radio"/> Enable <input checked="" type="radio"/> Disable
RSSI Threshold	-80 ▼ dB

Apply Cancel

Copyright 2017 © EDIMAX Technology Co., Ltd. All Rights Reserved

<b>SSID Selection</b>	Select a SSID to configure its security settings.
<b>Broadcast SSID</b>	<p>Enable or disable SSID broadcast.</p> <p>Enable: the SSID will be visible to clients as an available Wi-Fi network.</p> <p>Disable: the SSID will not be visible as an available Wi-Fi network to clients – clients must manually enter the SSID in order to connect. A hidden (disabled) SSID is typically more secure than a visible (enabled) SSID.</p>
<b>Wireless Client Isolation</b>	<p>Enable or disable wireless client isolation.</p> <p>Wireless client isolation prevents clients connected to the APt from communicating with each other and improves security. Typically, this function is useful for corporate environments or public hot spots and can prevent brute force attacks on clients' usernames and passwords.</p>
<b>Load Balancing</b>	Load balancing limits the number of wireless clients connected to an SSID. Set a load balancing value (maximum 100).
<b>Authentication Method</b>	Select an authentication method from the drop down menu and refer to the appropriate information below for your method.

#### iv. WDS (2.4GHz 11bgn)

WDS can bridge/repeat AP together in an extended network and must be configured on each AP, using correct MAC addresses. All APs should use the same wireless channel and encryption method.

 **When using WDS, configure the IP address of each AP to be in the same subnet and ensure there is only one active DHCP server among connected APs, preferably on the WAN side.**

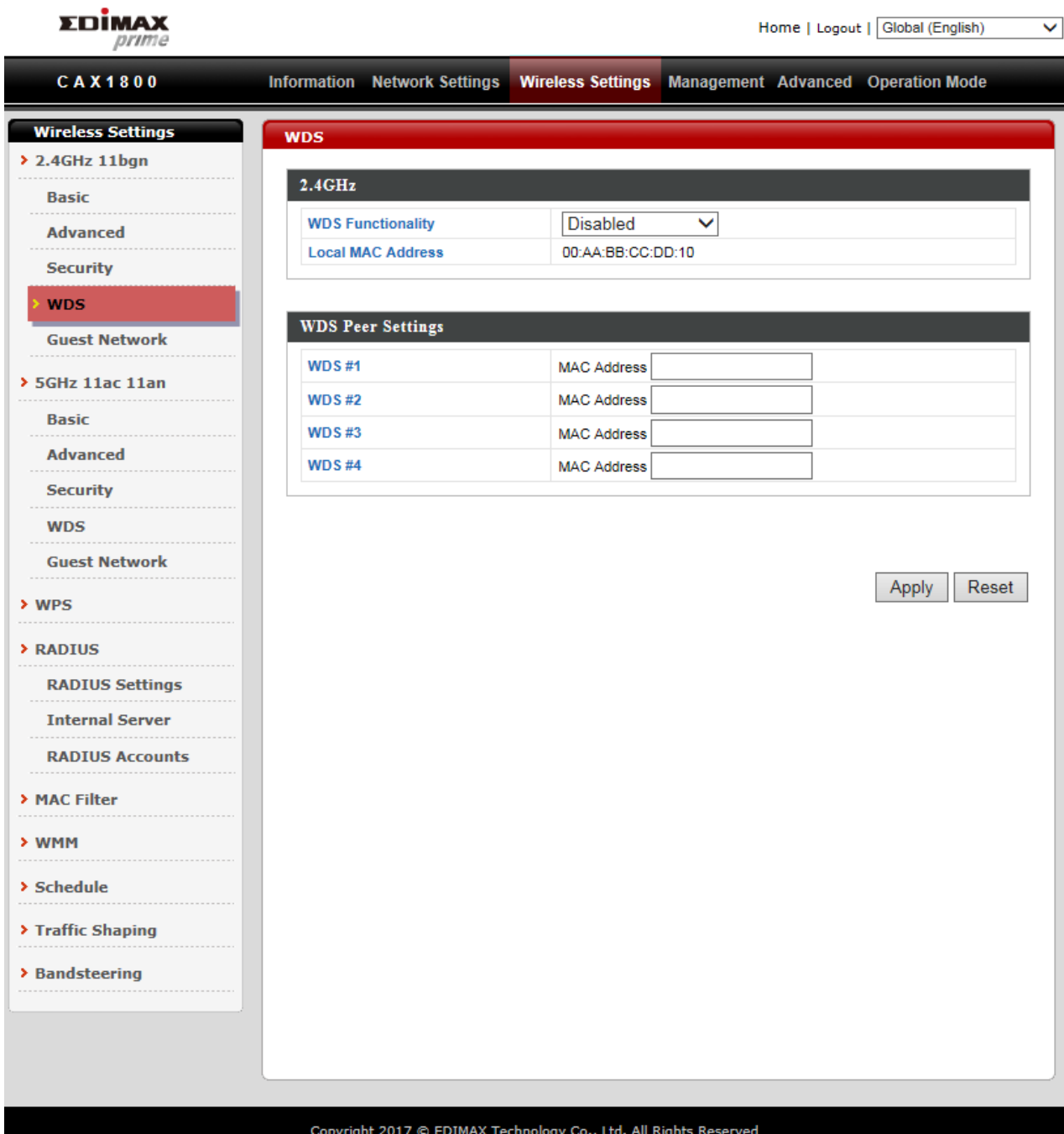

The screenshot shows the EDIMAX prime CAX1800 web interface. The top navigation bar includes 'Home | Logout | Global (English)'. The main menu has 'Wireless Settings' selected. The left sidebar shows 'Wireless Settings' expanded with 'WDS' selected. The main content area is titled 'WDS' and contains the following settings:

- 2.4GHz**
  - WDS Functionality: Disabled (dropdown menu)
  - Local MAC Address: 00:AA:BB:CC:DD:10
- WDS Peer Settings**

WDS #	MAC Address
WDS #1	<input type="text"/>
WDS #2	<input type="text"/>
WDS #3	<input type="text"/>
WDS #4	<input type="text"/>

At the bottom right of the WDS section, there are 'Apply' and 'Reset' buttons. The footer of the page reads 'Copyright 2017 © EDIMAX Technology Co., Ltd. All Rights Reserved'.

WDS settings can be configured as shown below:

2.4GHz	
<b>WDS Functionality</b>	Select “WDS with AP” to use WDS with AP or “WDS Dedicated Mode” to use WDS and also block communication with regular wireless clients. When WDS is used, each AP should be configured with corresponding MAC addresses, wireless channel and wireless encryption method.
<b>Local MAC Address</b>	Displays the MAC address of your AP.

WDS Peer Settings	
<b>WDS #</b>	Enter the MAC address for up to four other WDS devices you wish to connect.

WDS VLAN	
<b>VLAN Mode</b>	Specify the WDS VLAN mode to “Untagged Port” or “Tagged Port”.
<b>VLAN ID</b>	Specify the WDS VLAN ID when “Untagged Port” is selected above.

WDS Encryption method	
<b>Encryption</b>	Select whether to use “None” or “AES” encryption and enter a pre-shared key for AES consisting of 8-63 alphanumeric characters.

## v. Guest Network (2.4GHz 11bgn)

Enable or disable guest network to allow clients to connect as guests.

The screenshot displays the EDIMAX prime web interface. At the top, there is a navigation bar with the EDIMAX prime logo, a language dropdown set to 'Global (English)', and a 'Home | Logout' link. Below this is a secondary navigation bar with tabs for 'Information', 'Network Settings', 'Wireless Settings' (which is active), 'Management', 'Advanced', and 'Operation Mode'. The main content area is divided into a left sidebar and a right main panel. The sidebar, titled 'Wireless Settings', lists various configuration categories: 2.4GHz 11bgn, 5GHz 11ac 11an, WPS, RADIUS, MAC Filter, WMM, Schedule, Traffic Shaping, and Bandsteering. The '2.4GHz 11bgn' category is expanded, showing sub-options: Basic, Advanced, Security, WDS, Guest Network (highlighted in red), and WDS. The 'Guest Network' sub-option is selected, and the main panel displays the 'Guest Network' configuration form. This form includes a '2.4GHz SSID' dropdown menu set to 'CAX1800-CCDD10\_G', a 'Guest Network' label, and two radio buttons: 'Enable' (unselected) and 'Disable' (selected). At the bottom right of the form are 'Apply' and 'Cancel' buttons. The footer of the page contains the copyright notice: 'Copyright 2017 © EDIMAX Technology Co., Ltd. All Rights Reserved'.

## vi. 5GHz 11ac 11an

The “5GHz 11ac 11an” menu allows you to configure your AP 5GHz wireless network across five categories: Basic, Advanced, Security, WDS & Guest Network. Please refer to 2.4GHz 11bgn section for how to set up.

## vii. WPS

Please refer to PG.246 for more details.

## viii. RADIUS (RADIUS Settings)

The RADIUS allows users to configure the device's external RADIUS server settings.

A RADIUS server provides user-based authentication to improve security and offer wireless client control – users can be authenticated before gaining access to a network.

The device can utilize a primary and a secondary (backup) external RADIUS server for each of its wireless frequencies (2.4GHz & 5GHz).

The screenshot displays the EDIMAX prime CAX1800 web management interface. The top navigation bar includes 'Home | Logout | Global (English)'. The main menu shows 'Wireless Settings' selected, with sub-menus for '2.4GHz 11bgn', '5GHz 11ac 11an', 'WPS', 'RADIUS', 'MAC Filter', 'WMM', 'Schedule', 'Traffic Shaping', and 'Bandsteering'. The 'RADIUS' sub-menu is expanded, showing 'RADIUS Settings' as the active page. The 'RADIUS Settings' page is divided into two sections: 'RADIUS Server (2.4GHz)' and 'RADIUS Server (5GHz)'. Each section contains a 'Primary RADIUS Server' configuration block with the following fields: 'RADIUS Type' (radio buttons for Internal and External, with External selected), 'RADIUS Server' (text input), 'Authentication Port' (text input, value 1812), 'Shared Secret' (text input), 'Session Timeout' (text input, value 3600, followed by 'second(s)'), 'Accounting' (radio buttons for Enable and Disable, with Enable selected), and 'Accounting Port' (text input, value 1813). A 'Secondary RADIUS Server' configuration block is also present in each section, with identical fields and values. The footer of the interface reads 'Copyright 2017 © EDIMAX Technology Co., Ltd. All Rights Reserved'.

The screenshot displays the EDIMAX prime CAX1800 wireless settings interface. The 'RADIUS Settings' section is active, showing configuration for both Primary and Secondary RADIUS Servers. The Primary RADIUS Server configuration includes:
 

- RADIUS Type:  Internal,  External
- RADIUS Server: [Empty text box]
- Authentication Port: 1812
- Shared Secret: [Empty text box]
- Session Timeout: 3600 second(s)
- Accounting:  Enable,  Disable
- Accounting Port: 1813

 The Secondary RADIUS Server configuration includes:
 

- RADIUS Type:  Internal,  External
- RADIUS Server: [Empty text box]
- Authentication Port: 1812
- Shared Secret: [Empty text box]
- Session Timeout: 3600 second(s)
- Accounting:  Enable,  Disable
- Accounting Port: 1813

 The interface also features a left-hand navigation menu with options like '2.4GHz 11bgn', '5GHz 11ac 11an', 'WPS', 'RADIUS', 'MAC Filter', 'WMM', 'Schedule', 'Traffic Shaping', and 'Bandsteering'. The 'RADIUS Settings' option is currently selected. At the bottom right, there are 'Apply' and 'Cancel' buttons. The footer indicates 'Copyright 2017 © EDIMAX Technology Co., Ltd. All Rights Reserved'.

<b>RADIUS Type</b>	Select “Internal” to use the AP built-in RADIUS server or “external” to use an external RADIUS server.
<b>RADIUS Server</b>	Enter the RADIUS server host IP address.
<b>Authentication Port</b>	Set the UDP port used in the authentication protocol of the RADIUS server.
<b>Shared Secret</b>	Enter a shared secret/password between 1 – 99 characters in length.
<b>Session Timeout</b>	Set a duration of session timeout in seconds between 0 – 86400.
<b>Accounting</b>	Enable or disable RADIUS accounting.
<b>Accounting Port</b>	When accounting is enabled (above), set the UDP port used in the accounting protocol of the RADIUS server.

## ix. Internal Server

The AP features a built-in RADIUS server which can be configured as shown below used when “Internal” is selected for “RADIUS Type”.

The screenshot displays the EDIMAX prime CAX1800 web management interface. The top navigation bar includes 'Home | Logout | Global (English)'. The main menu shows 'Wireless Settings' as the active section, with sub-menus for 'Information', 'Network Settings', 'Management', 'Advanced', and 'Operation Mode'. The left sidebar lists various settings categories, with 'RADIUS Settings' expanded to show 'Internal Server' selected. The main content area is titled 'Internal Server' and contains the following configuration fields:

Internal Server	<input type="checkbox"/> Enable
EAP Internal Authentication	PEAP(MS-PEAP) ▼
EAP Certificate File Format	PKCS#12(*.pfx/*.p12)
EAP Certificate File	<input type="button" value="Upload"/>
Shared Secret	<input type="text"/>
Session-Timeout	<input type="text" value="3600"/> second(s)
Termination-Action	<input checked="" type="radio"/> Reauthentication (RADIUS-Request) <input type="radio"/> Not-Reauthentication (Default) <input type="radio"/> Not-Send

At the bottom right of the configuration area, there are 'Apply' and 'Cancel' buttons. The footer of the page reads 'Copyright 2017 © EDIMAX Technology Co., Ltd. All Rights Reserved'.

<b>Internal Server</b>	Check/uncheck to enable/disable the AP's internal RADIUS server.
<b>EAP Internal Authentication</b>	Select EAP internal authentication type from the drop down menu.
<b>EAP Certificate File Format</b>	Displays the EAP certificate file format: PCK#12(*.pfx/*.p12)
<b>EAP Certificate File</b>	Click "Upload" to open a new window and select the location of an EAP certificate file to use. If no certificate file is uploaded, the internal RADIUS server will use a self-made certificate.
<b>Shared Secret</b>	Enter a shared secret/password for use between the internal RADIUS server and RADIUS client. The shared secret should be 1 – 99 characters in length.
<b>Session Timeout</b>	Set a duration of session timeout in seconds between 0 – 86400.
<b>Termination Action</b>	Select a termination-action attribute: Reauthentication: sends a RADIUS request to the AP; or, Not-Reauthentication: sends a default termination-action attribute to the AP; or Not-Send: no termination-action attribute is sent to the AP.

## x. RADIUS Accounts

The internal RADIUS server allows you to configure and manage users and can authenticate up to 256 user accounts.

The screenshot shows the EDIMAX prime CAX1800 web interface. The top navigation bar includes 'Home | Logout | Global (English)'. The main menu includes 'Information', 'Network Settings', 'Wireless Settings', 'Management', 'Advanced', and 'Operation Mode'. The left sidebar lists various settings categories, with 'RADIUS Accounts' highlighted. The main content area is titled 'RADIUS Accounts (Max: 256 users)' and contains a 'User Name' input field with an example 'USER1, USER2, USER3, USER4' and a large text area for user details. Below these are 'Add' and 'Reset' buttons. The 'User Registration List' section shows a table with columns for 'Select', 'User Name', 'Password', and 'Customize'. The table currently contains no entries, displaying 'No user entries'. Below the table are 'Delete Selected' and 'Delete All' buttons. The footer of the page reads 'Copyright 2017 © EDIMAX Technology Co., Ltd. All Rights Reserved'.

Enter a username in the box below and click “Add” to add the username.

The close-up screenshot shows the 'User Registration List' table with the following data:

Select	User Name	Password	Customize
<input type="checkbox"/>	USER1	Not Configured	Edit

Below the table are 'Delete Selected' and 'Delete All' buttons.

Select “Edit” to edit the username and password of the RADIUS account:

Edit User Registration List		
User Name	USER1	(4-16Characters)
Password		(6-32Characters)
		Apply Cancel

<b>User Name</b>	Enter the user names here, separated by commas.
<b>Add</b>	Click “Add” to add the user to the user registration list.
<b>Reset</b>	Clear text from the user name box.

<b>Select</b>	Check the box to select a user.
<b>User Name</b>	Displays the user name.
<b>Password</b>	Displays if specified user name has a password (configured) or not (not configured).
<b>Customize</b>	Click “Edit” to open a new field to set/edit a password for the specified user name.

<b>Delete Selected</b>	Delete selected user from the user registration list.
<b>Delete All</b>	Delete all users from the user registration list.

## xi. MAC Filter

MAC filtering is a security feature that can help to prevent unauthorized users from connecting to your AP.

This function allows users to define a list of network devices permitted to connect to the AP. Devices are each identified by their unique MAC address. If a device which is not on the list of permitted MAC addresses attempts to connect to the AP, it will be denied.

The MAC address filtering table is displayed below:

The screenshot displays the EDIMAX prime web interface for the CAX1800 device. The top navigation bar includes 'Home | Logout | Global (English)'. The main menu shows 'Wireless Settings' as the active section. The left sidebar lists various settings, with 'MAC Filter' highlighted. The main content area is titled 'MAC Filter' and contains the following elements:

- Add MAC Addresses** section: Includes 'Enable Wireless Access Control' (radio buttons for Enable and Disable, with 'Enable' selected) and 'Wireless Access Control Mode' (dropdown menu set to 'Whitelist'). An 'Apply' button is located below.
- Add MAC Addresses** section: A large empty text area for entering MAC addresses, with 'Add' and 'Reset' buttons below it.
- MAC Address Filtering Table (Max: 256)**: A table with columns 'Select' and 'MAC Address'. The table is currently empty, displaying 'No MAC Address entries.' Below the table are 'Delete Selected', 'Delete All', and 'Export' buttons.

Copyright 2017 © EDIMAX Technology Co., Ltd. All Rights Reserved

<b>Add MAC Address</b>	Enter a MAC address of computer or network device manually e.g. 'aa-bb-cc-dd-ee-ff'. Or enter multiple MAC addresses separated with commas, e.g. 'aa-bb-cc-dd-ee-ff,aa-bb-cc-dd-ee-gg'.
<b>Add</b>	Click "Add" to add the MAC address to the MAC address filtering table.
<b>Reset</b>	Clear all fields.

MAC address entries will be listed in the "MAC Address Filtering Table". Select an entry using the "Select" checkbox.

MAC Address Filtering Table	
Select	MAC Address
No MAC Address entries.	
<input type="button" value="Delete Selected"/> <input type="button" value="Delete All"/> <input type="button" value="Export"/>	

<b>Select</b>	Delete selected or all entries from the table.
<b>MAC Address</b>	The MAC address is listed here.
<b>Delete Selected</b>	Delete the selected MAC address from the list.
<b>Delete All</b>	Delete all entries from the MAC address filtering table.
<b>Export</b>	Click "Export" to save a copy of the MAC filtering table. A new window will pop up for you to select a location to save the file.

## xii. WMM

WMM is a Wi-Fi Alliance interoperability certification based on the IEEE 802.11e standard, which provides Quality of Service (QoS) features to IEEE 802.11 networks. WMM prioritizes traffic according to four categories: background, best effort, video and voice.

The screenshot shows the EDIMAX prime web interface for a CA X 1800 device. The navigation menu on the left includes sections for 2.4GHz 11bgn, 5GHz 11ac 11an, WPS, RADIUS, MAC Filter, WMM (highlighted), Schedule, Traffic Shaping, and Bandsteering. The main content area displays the WMM settings, specifically the WMM-EDCA Settings. It contains two tables: 'WMM Parameters of Access Point' and 'WMM Parameters of Station'. Both tables list parameters for Back Ground, Best Effort, Video, and Voice categories, including CWMin, CWMax, AIFSN, and TxOP values. The 'Apply' and 'Cancel' buttons are visible at the bottom right of the settings area.

WMM Parameters of Access Point				
	CWMin	CWMax	AIFSN	TxOP
Back Ground	4	10	7	0
Best Effort	4	6	3	0
Video	3	4	1	94
Voice	2	3	1	47

WMM Parameters of Station				
	CWMin	CWMax	AIFSN	TxOP
Back Ground	4	10	7	0
Best Effort	4	10	3	0
Video	3	4	2	94
Voice	2	3	2	47

Configuring WMM consists of adjusting parameters on queues for different categories of wireless traffic. Traffic is sent to the following queues:

<b>Background</b>	Low Priority	High throughput, non time sensitive bulk data e.g. FTP
<b>Best Effort</b>	Medium Priority	Traditional IP data, medium throughput and delay.
<b>Video</b>	High Priority	Time sensitive video data with minimum time delay.
<b>Voice</b>	High Priority	Time sensitive data such as VoIP and streaming media with minimum time delay.

Queues automatically provide minimum transmission delays for video, voice, multimedia and critical applications. The values can be adjusted further manually:

<b>CWMin</b>	Minimum Contention Window (milliseconds): This value is input to the initial random backoff wait time algorithm for retry of a data frame transmission. The backoff wait time will be generated between 0 and this value. If the frame is not sent, the random backoff value is doubled until the value reaches the number defined by CWMax (below). The CWMin value must be lower than the CWMax value.
<b>CWMax</b>	Maximum Contention Window (milliseconds): This value is the upper limit to random backoff value doubling (see above).
<b>AIFSN</b>	Arbitration Inter-Frame Space (milliseconds): Specifies additional time between when a channel goes idle and the AP/client sends data frames. (Traffic with a lower AIFSN value has a higher priority)
<b>TxOP</b>	Transmission Opportunity (milliseconds): The maximum interval of time an AP can transmit. This makes channel access more efficiently prioritized. (A greater value means higher priority)

### xiii. Schedule

The schedule feature allows users to automate the wireless network for the specified time ranges. Wireless scheduling can save energy and increase the security of your network.

The screenshot shows the EDIMAX prime CAX1800 web interface. The top navigation bar includes 'Home | Logout | Global (English)'. The main menu has 'Wireless Settings' selected. The left sidebar lists various settings, with 'Schedule' highlighted in red. The main content area is titled 'Schedule' and contains the following elements:

- Instruction: "Enable the wireless network during the following schedules."
- Warning: "This function will not work until date and time are set." with a 'Settings' button.
- Form: A field labeled 'Schedule' with an 'Enable' checkbox.
- Button: An 'Apply' button.
- Table: A 'Schedule List' table with columns: #, SSID, Day of Week, Time, and Select. The table is currently empty, displaying "No schedule entries".
- Buttons: 'Add', 'Edit', 'Delete Selected', and 'Delete All' buttons located below the table.

Copyright 2017 © EDIMAX Technology Co., Ltd. All Rights Reserved

Please follow the steps below for how to set up schedule,

1. Select "Add" to add a schedule.
2. Settings page will be shown if "Continue" is selected. Check the box of the desired SSID network, day of schedule and select the Start Time and End Time.

**Settings**

2.4GHz SSID		5GHz SSID	
<input type="checkbox"/>	CAX1800-BADBAD_G	<input type="checkbox"/>	CAX1800-BADBAD_A

Sun.	Mon.	Tue.	Wed.	Thu.	Fri.	Sat.
<input type="checkbox"/>	<input type="checkbox"/>	<input type="checkbox"/>	<input type="checkbox"/>	<input type="checkbox"/>	<input type="checkbox"/>	<input type="checkbox"/>

Start Time  :  End Time  :

**Schedule List**

#	SSID	Day of Week	Time	Select
1	CAX1800-BADBAD...	Mon. Tue.	04:00-12:00	<input type="checkbox"/>

## xiv. Traffic Shaping

Traffic shaping is used to optimize or guarantee performance, improve latency, or increase usable bandwidth for some kinds of packets by delaying other kinds.

EDIMAX prime Home | Logout | Global (English) ▼

CAX1800 Information Network Settings Wireless Settings Management Advanced Operation Mode

**Wireless Settings**

- > 2.4GHz 11bgn
  - Basic
  - Advanced
  - Security
  - WDS
  - Guest Network
- > 5GHz 11ac 11an
  - Basic
  - Advanced
  - Security
  - WDS
  - Guest Network
- > WPS
- > RADIUS
  - RADIUS Settings
  - Internal Server
  - RADIUS Accounts
- > MAC Filter
- > WMM
- > Schedule
- > **Traffic Shaping**
- > Bandsteering

**Traffic Shaping**

**Traffic Shaping for ssid(2.4GHz)**

Enable

Unlimited : 0 Mbps

Down Link/Up Link Maximum : 1024 Mbps

SSID	Down Link	Up Link
CAX1800-CCDD10_G	0 Mbps	0 Mbps
<input type="checkbox"/> Each Client	0 Mbps	0 Mbps
CAX1800-CCDD10_G_2	0 Mbps	0 Mbps
<input type="checkbox"/> Each Client	0 Mbps	0 Mbps
CAX1800-CCDD10_G_3	0 Mbps	0 Mbps
<input type="checkbox"/> Each Client	0 Mbps	0 Mbps
CAX1800-CCDD10_G_4	0 Mbps	0 Mbps
<input type="checkbox"/> Each Client	0 Mbps	0 Mbps
CAX1800-CCDD10_G_5	0 Mbps	0 Mbps
<input type="checkbox"/> Each Client	0 Mbps	0 Mbps
CAX1800-CCDD10_G_6	0 Mbps	0 Mbps
<input type="checkbox"/> Each Client	0 Mbps	0 Mbps
CAX1800-CCDD10_G_7	0 Mbps	0 Mbps
<input type="checkbox"/> Each Client	0 Mbps	0 Mbps
CAX1800-CCDD10_G_8	0 Mbps	0 Mbps
<input type="checkbox"/> Each Client	0 Mbps	0 Mbps
CAX1800-CCDD10_G_9	0 Mbps	0 Mbps
<input type="checkbox"/> Each Client	0 Mbps	0 Mbps
CAX1800-CCDD10_G_10	0 Mbps	0 Mbps
<input type="checkbox"/> Each Client	0 Mbps	0 Mbps
CAX1800-CCDD10_G_11	0 Mbps	0 Mbps
<input type="checkbox"/> Each Client	0 Mbps	0 Mbps

Copyright 2017 © EDIMAX Technology Co., Ltd. All Rights Reserved

## xv. Bandsteering

Bandsteering detects clients capable of 5GHz operation and steers them there to make the more crowded 2.4 GHz band available for clients only capable of connecting to 2.4GHz band. This helps improve end user experience by reducing channel utilization, especially in high density environments.

The screenshot shows the EDIMAX prime web interface. The top navigation bar includes 'Home | Logout | Global (English)'. The main menu has 'Wireless Settings' selected. The left sidebar lists various settings categories, with 'Bandsteering' highlighted. The main content area displays the 'Bandsteering' configuration page, which includes a radio button selection for 'Off', '5G First', 'Balanced', and 'User Define'. The 'User Define' option is selected. There are 'Apply' and 'Cancel' buttons at the bottom right of the configuration area. The footer of the interface reads 'Copyright 2017 © EDIMAX Technology Co., Ltd. All Rights Reserved'.

Bandsteering	
Bandsteering	<input type="radio"/> Off <input type="radio"/> 5G First <input type="radio"/> Balanced <input checked="" type="radio"/> User Define
2.4GHz Overload Threshold	<input type="text" value="70"/> (0-100%, suggest:70) Channel utilization percentage
5GHz Overload Threshold	<input type="text" value="70"/> (0-100%, suggest:70) Channel utilization percentage
Min RSSI	<input type="text" value="-75"/> dB

## V-4. Management

CAX1800		Information	Network Settings	Wireless Settings	Management	Advanced	Operation Mode
---------	--	-------------	------------------	-------------------	------------	----------	----------------

Management	
> Admin	
> Date and Time	
> Syslog Server	
> Ping Test	
> Traceroute Test	

Admin	
<b>Account to Manage This Device</b>	
Administrator Name	admin
Administrator Password	..... (4-32Characters)
	..... (Confirm)
<input type="button" value="Apply"/>	
<b>Advanced Settings</b>	
Product Name	AP00AABBCCDD10
HTTP Port	80 (80, 1024-65535)
HTTPS Port	443 (443, 1024-65535)
Management Protocol	<input checked="" type="checkbox"/> HTTP <input checked="" type="checkbox"/> HTTPS <input checked="" type="checkbox"/> TELNET <input type="checkbox"/> SSH <input checked="" type="checkbox"/> SNMP
SNMP Version	v1/v2c ▼
SNMP Get Community	public
SNMP Set Community	private
SNMP V3 Name	admin
SNMP V3 Password	.....
SNMP Trap	Disabled ▼
SNMP Trap Community	public
SNMP Trap Manager	
<input type="button" value="Apply"/>	

## i. Admin

You can change the admin name/password and configure the “Advanced Settings” in here. It is advised to do so for security purposes.

Account to Manage This Device	
Administrator Name	<input type="text" value="admin"/>
Administrator Password	<input type="password" value="....."/> (4-32Characters)
	<input type="password" value="....."/> (Confirm)
<input type="button" value="Apply"/>	

Account to Manage This Device	
<b>Administrator Name</b>	Set the AP administrator name. (Must be between 4-16 alphanumeric characters)
<b>Administrator Password</b>	Set the AP administrator password. (Must be between 4-32 alphanumeric characters)

Advanced Settings	
Product Name	<input type="text" value="AP00037FBADBAD"/>
HTTP Port	<input type="text" value="80"/> (80, 1024-65535)
HTTPS Port	<input type="text" value="443"/> (443, 1024-65535)
Management Protocol	<input checked="" type="checkbox"/> HTTP <input checked="" type="checkbox"/> HTTPS <input checked="" type="checkbox"/> TELNET <input type="checkbox"/> SSH <input checked="" type="checkbox"/> SNMP
Login Timeout	<input type="text" value="5"/> (mins)
SNMP Version	<input type="text" value="v1/v2c"/>
SNMP Get Community	<input type="text" value="public"/>
SNMP Set Community	<input type="text" value="private"/>
SNMP V3 Name	<input type="text" value="admin"/>
SNMP V3 Password	<input type="password" value="....."/>
SNMP Trap	<input type="text" value="Disabled"/>
SNMP Trap Community	<input type="text" value="public"/>
SNMP Trap Manager	<input type="text" value=""/>
<input type="button" value="Apply"/>	

Advanced Settings	
<b>Product Name</b>	Edit the product name according to your preference consisting of 1-32 alphanumeric characters. This name is used for reference purposes.
<b>Management Protocol</b>	Check/uncheck the boxes to enable/disable specified management interfaces.
<b>SNMP Version</b>	Select SNMP version appropriate for your SNMP manager.
<b>SNMP Get Community</b>	Enter an SNMP Get Community name for verification with the SNMP manager for SNMP-GET requests.
<b>SNMP Set Community</b>	Enter an SNMP Set Community name for verification with the SNMP manager for SNMP-SET requests.
<b>SNMP Trap</b>	Enable or disable SNMP Trap to notify SNMP manager of network errors.
<b>SNMP Trap Community</b>	Enter an SNMP Trap Community name for verification with the SNMP manager for SNMP-TRAP requests.
<b>SNMP Trap Manager</b>	Specify the IP address or sever name (2-128 alphanumeric characters) of the SNMP manager.

## ii. Date and Time

Users can configure the date and time settings of the AP here. The date and time of the device can be configured manually or can be synchronized with a time server.

Date and Time Settings	
<b>Local Time</b>	Set the AP date and time manually using the drop down menus.
<b>Acquire Current Time from your PC</b>	Click “Acquire Current Time from Your PC” to enter the required values automatically according to your computer’s current time and date.

NTP Time Server	
<b>Use NTP</b>	The AP also supports NTP (Network Time Protocol) for automatic time and date setup.
<b>Server Name</b>	Enter the host name or IP address of the time server if you wish.
<b>Update Interval</b>	Specify a frequency (in hours) for the AP to update/synchronize with the NTP server.

Time Zone	
<b>Time Zone</b>	Select the time zone of your country/region. If your country/region is not listed, please select another country/region whose time zone is the same as yours.

### iii. Syslog Server

You can send the system log to a server.

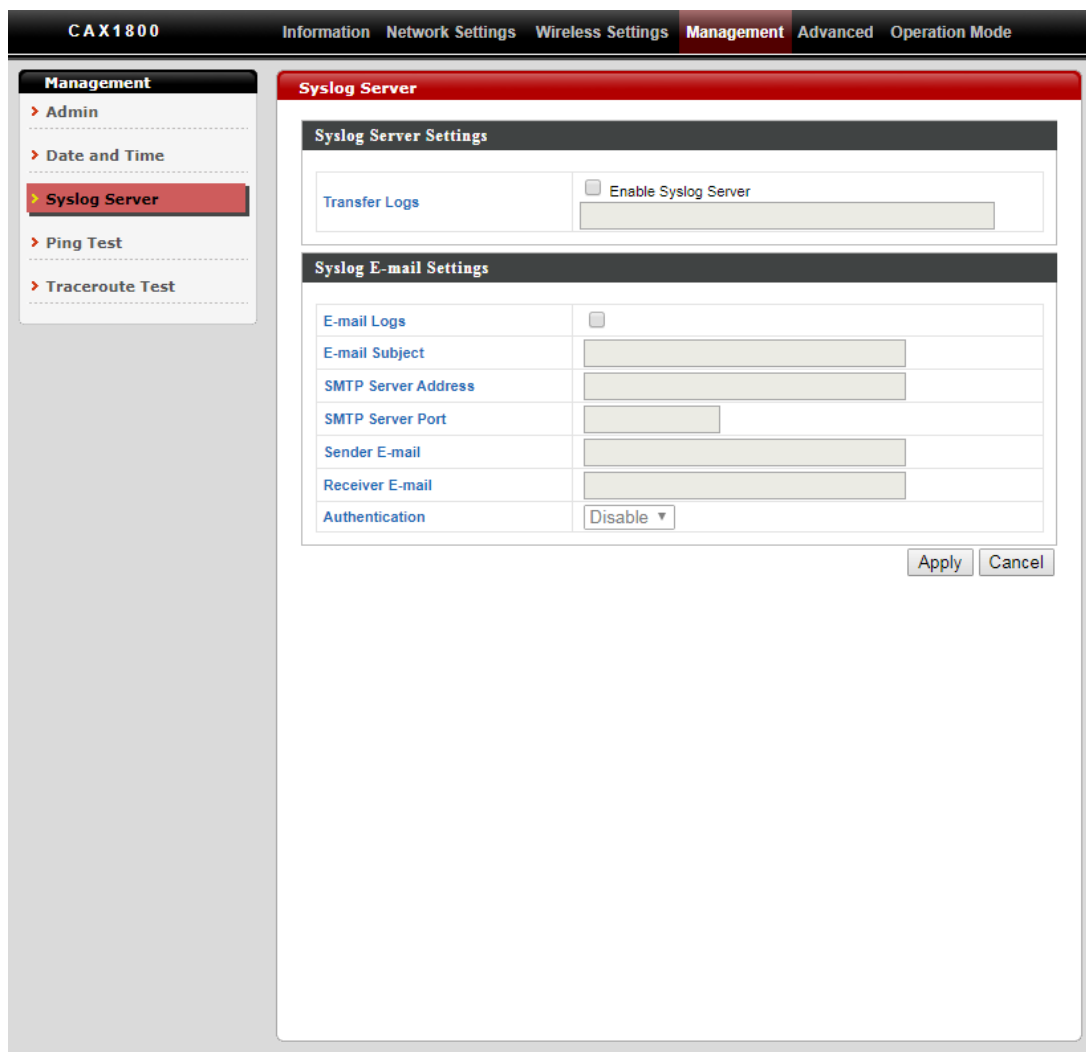

Syslog Server Settings	
<b>Transfer Logs</b>	Check the box to enable the use of a syslog server. Enter a host name, domain or IP address for the server, consisting of up to 128 alphanumeric characters.

Syslog E-mail Settings	
<b>E-mail Logs</b>	Check the box to enable/disable e-mail logs.
<b>E-mail Subject</b>	Specify the subject line of log emails.
<b>SMTP Server Address</b>	Specify the SMTP server address used to send log emails.
<b>SMTP Server Port</b>	Specify the SMTP server port used to send log emails.
<b>Sender E-mail</b>	Specify the sender email address.
<b>Receiver E-mail</b>	Specify the email to receive log emails.
<b>Authentication</b>	Disable or select authentication type: SSL or TLS. When using SSL or TLS, enter the username and password.

## iv. Ping Test

The AP includes a built-in ping test function.

The screenshot displays the web management interface for a CAX1800 device. At the top, a navigation bar includes 'CAX1800' and menu items: 'Information', 'Network Settings', 'Wireless Settings', 'Management' (highlighted), 'Advanced', and 'Operation Mode'. On the left, a 'Management' sidebar lists options: 'Admin', 'Date and Time', 'Syslog Server', 'Ping Test' (highlighted), and 'Traceroute Test'. The main content area is titled 'Ping Test' and features a 'Destination Address' input field and an 'Execute' button. Below this is a 'Result' section with a large, empty grey rectangular area for displaying test outcomes.

<b>Destination Address</b>	Enter the address of the host.
<b>Execute</b>	Click the “Execute” button to ping the host.

## v. Traceroute Test

Traceroute is a diagnostic tool for displaying the route and measuring transit delays of packets across an IP network.

The screenshot shows the web interface for a CAX1800 device. At the top, there is a navigation bar with the following tabs: Information, Network Settings, Wireless Settings, Management (selected), Advanced, and Operation Mode. On the left side, there is a 'Management' menu with the following options: Admin, Date and Time, Syslog Server, Ping Test, and Traceroute Test (highlighted in red). The main content area is titled 'Traceroute Test' and contains a 'Destination Address' input field and an 'Execute' button. Below the input field, there is a 'Result' section with a large, empty gray box for displaying the test results.

<b>Destination Address</b>	Enter the address of the host.
<b>Execute</b>	Click the “Execute” button to execute the traceroute command.

## V-5. Advanced

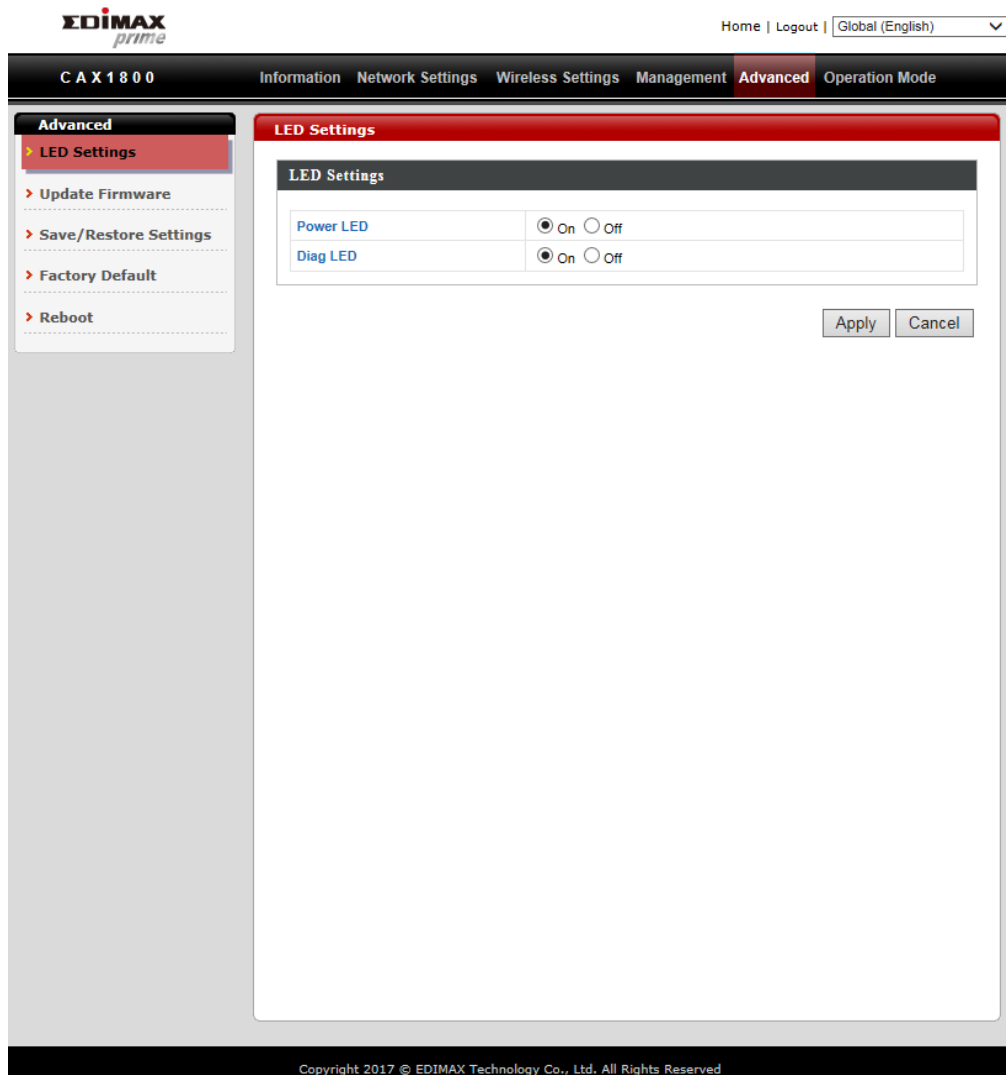

### i. LED Settings

The AP LEDs can be manually enabled or disabled according to your preference.

LED Settings	
Power LED	<input checked="" type="radio"/> On <input type="radio"/> Off
Diag LED	<input checked="" type="radio"/> On <input type="radio"/> Off
<input type="button" value="Apply"/> <input type="button" value="Cancel"/>	

<b>Power LED</b>	Select on or off.
<b>Diag LED</b>	Select on or off.

## ii. Update Firmware

The “Firmware” page allows users to update the firmware of the system.



**Do not switch off or disconnect the AP during a firmware upgrade, as this could damage the device.**

Auto Update Firmware	
Current Firmware Version	1.0.0
Server Firmware Version	

Firmware updated. Rebooting now...

Please wait for 1 seconds.

**Firmware Location**

Click “Choose File” to upload firmware from your local computer.

### iii. Save / Restore Settings

Users can save / backup the device’s current settings as a file to your local computer, and restore the device to previously saved settings.

Save Settings to PC	
<b>Save Settings</b>	Encryption: If you wish to encrypt the configuration file with a password, check the “Encrypt the configuration file with a password” box and enter a password. Click “Save” to save current settings. A new window will open to allow you to specify a location to save to.

Restore Settings from PC	
<b>Restore Settings</b>	Click the “Choose File” button to find a previously saved settings file on your computer. If your settings file is encrypted with a password, check the “Open file with password” box and enter the password in the following field. Click “Restore” to replace your current settings.

## iv. Factory Default

If the AP malfunction or is not responding, rebooting the device maybe an option to consider. If rebooting does not work, try resetting the device back to its factory default settings.



<b>Factory Default</b>	Click “Factory Default” to restore settings to the factory default. A pop-up window will appear and ask you to confirm.
------------------------	---



**After resetting to factory defaults, please wait for the AP to reset and restart.**

## v. Reboot

If the AP malfunctions or is not responding, rebooting the device may be an option to consider.

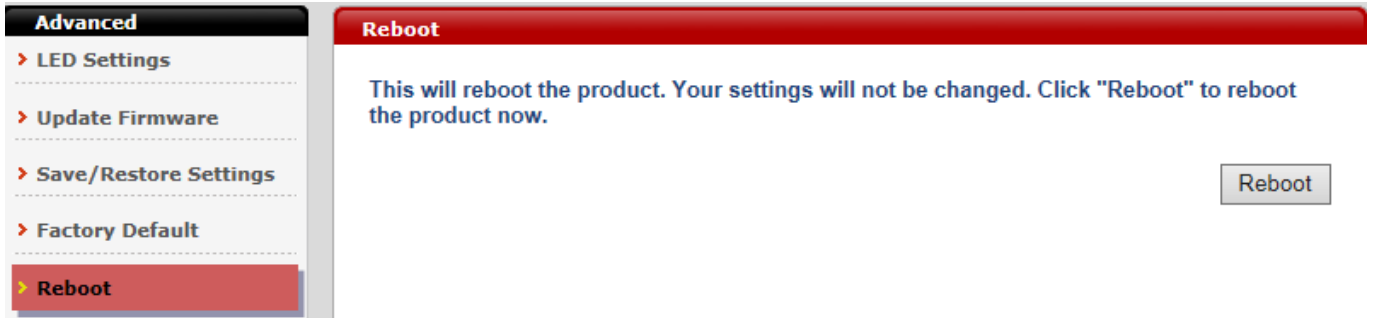

<b>Reboot</b>	Click "Reboot" to reboot the device. A countdown will indicate the progress of the reboot.
---------------	--

## V-6. Operation Mode

The screenshot shows a web interface for configuring an AP. On the left is a sidebar with 'Operation Mode' selected. The main panel has a red header 'Operation Mode'. Below it is a section titled 'Operation Mode' containing a dropdown menu currently set to 'AP Mode'. Below that is a section titled 'Wireless Mode' containing two rows: '2.4GHz Mode' and '5GHz Mode', each with a dropdown menu set to 'Access Point'. At the bottom right are 'Apply' and 'Cancel' buttons.

The AP can function in three different modes. Set the operation mode of the AP here.

1. AP Mode: The device acts as a standalone AP
2. AP controller Mode: The device acts as the designated master of the AP array
3. Managed AP Mode: The device acts as a slave AP within the AP array.

 **In Managed AP mode some functions of the AP will be disabled in this user interface and must be set using Edimax Pro NMS on the AP Controller.**

 **In AP Controller Mode the AP will switch to the Edimax Pro NMS user interface.**

This screenshot is identical to the one above, but the 'Operation Mode' dropdown menu is open, showing three options: 'AP Mode' (highlighted in blue), 'AP Controller Mode', and 'Managed AP mode'. The 'Wireless Mode' section and 'Apply/Cancel' buttons remain the same.

A close-up of the dropdown menu from the previous screenshot. It shows three items: 'AP Mode' (selected and highlighted in blue), 'AP Controller Mode', and 'Managed AP mode'. A small downward arrow is visible at the top right of the menu.

## VI. Edimax Pro NMS

---

Edimax Pro Network Management Suite (NMS) supports the central management of a group of APs, otherwise known as an AP Array. NMS can be installed on one AP and support up to 16 Edimax Pro APs with no additional wireless controller required, reducing costs and facilitating efficient remote AP management.

APs can be deployed and configured according to requirements, creating a powerful network architecture which can be easily managed and expanded in the future, with an easy to use interface and a full range of functionality – ideal for small and mid-sized office environments. A secure WLAN can be deployed and administered from a single point, minimizing cost and complexity.

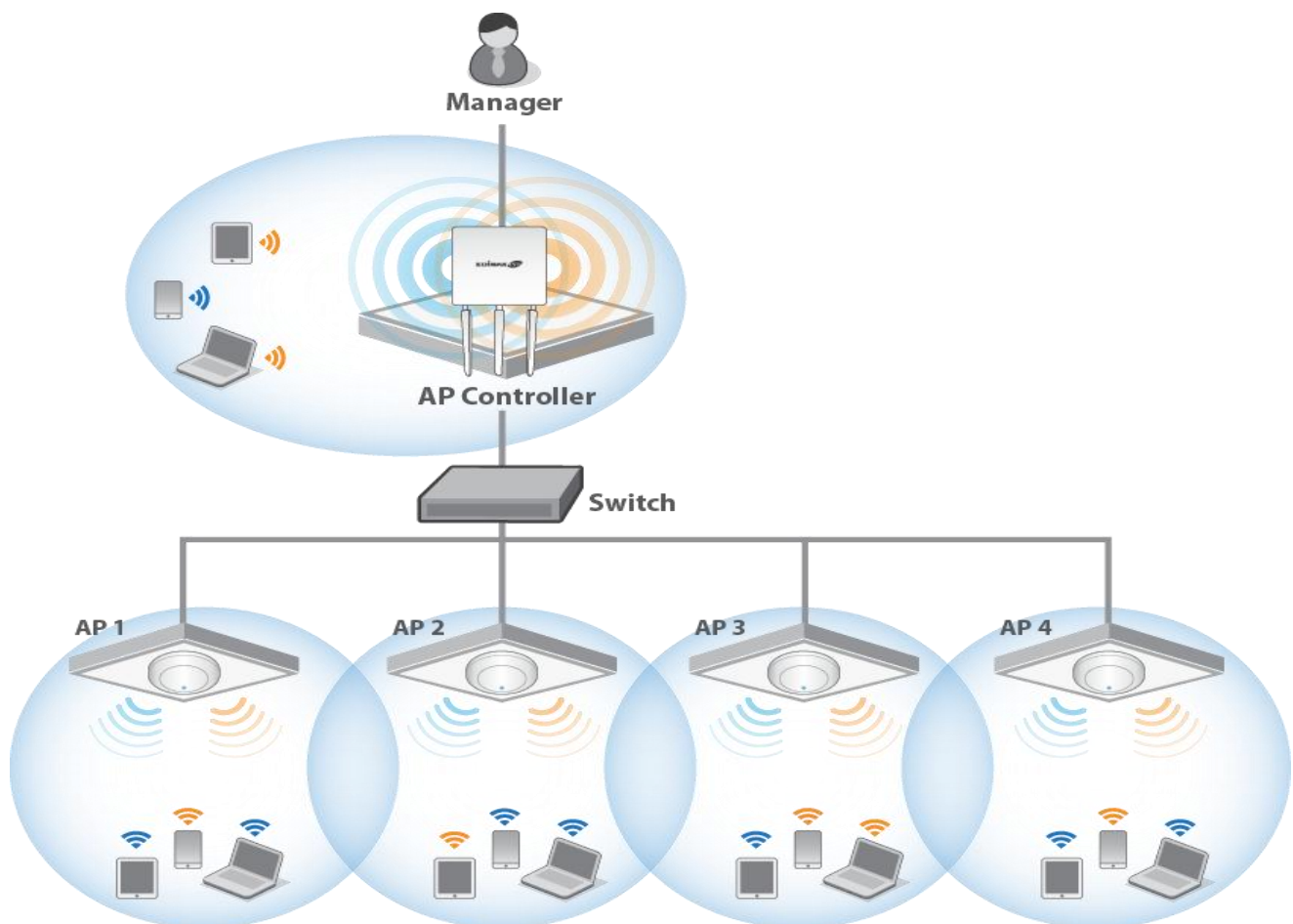

## VI-1. Quick Setup – NMS

Edimax Network Management System (NMS) supports the central management of a group of APs, otherwise known as an AP Array. NMS can be installed on one AP and support up to 16 Edimax APs with no additional wireless controller required, reducing costs and facilitating efficient remote AP management.

NMS is simple to setup. An overview of the system is shown below:

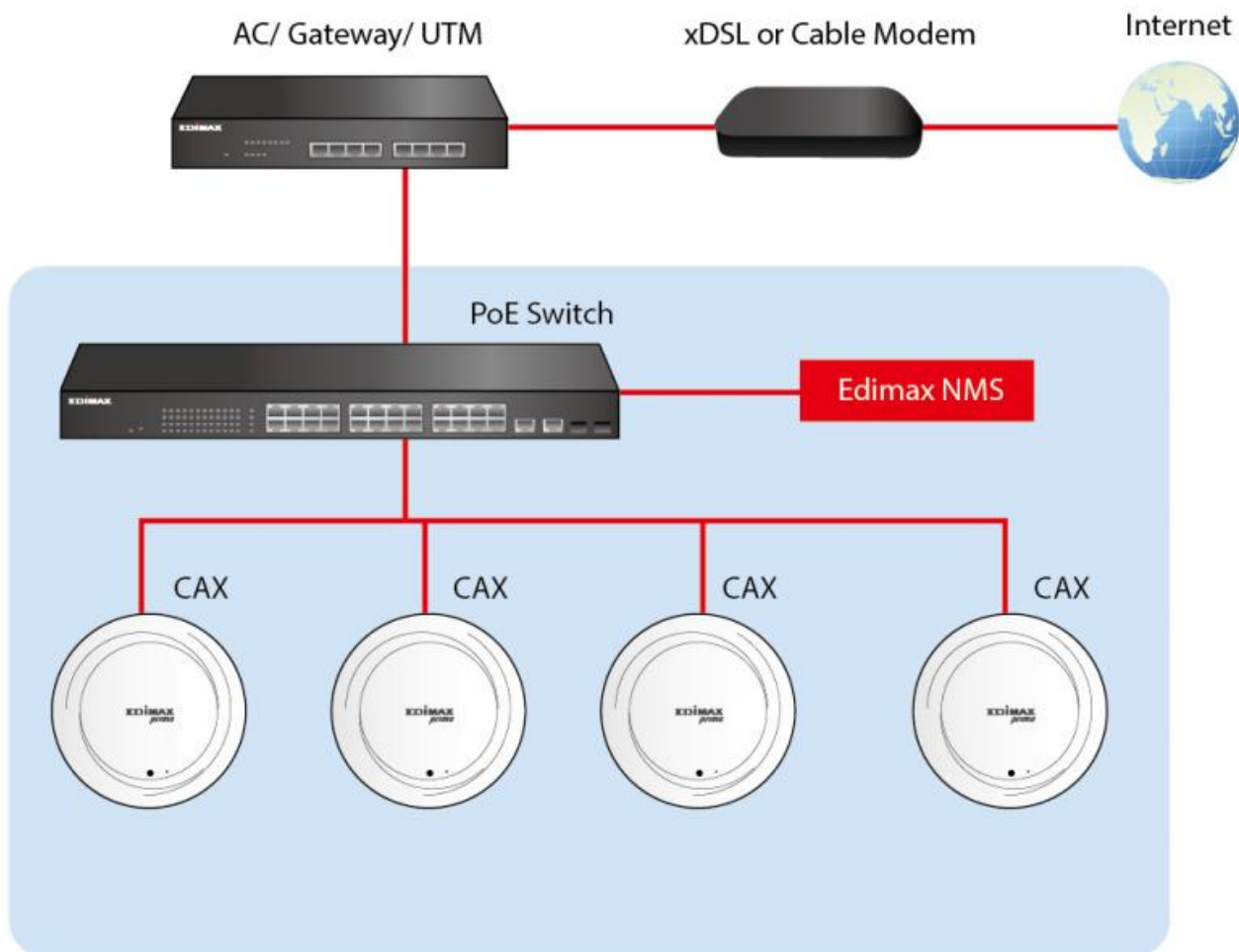

One AP is designated as the AP Controller (master) and other connected Edimax APs are automatically designated as Managed APs (slaves). Using Edimax NMS you can monitor, configure and manage all Managed APs (up to 16) from the single AP Controller.

**Please follow the steps below for how to setup:**

1. Connect all APs to a switch which is connected to a router.

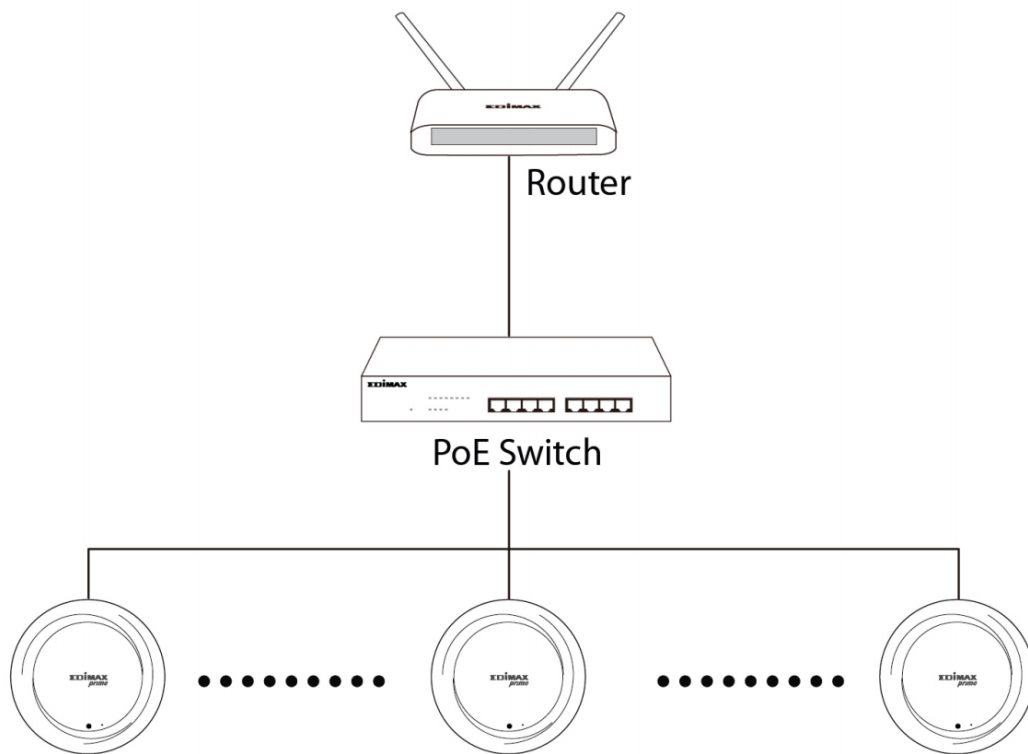

2. Ensure all APs are powered on and check their LEDs.

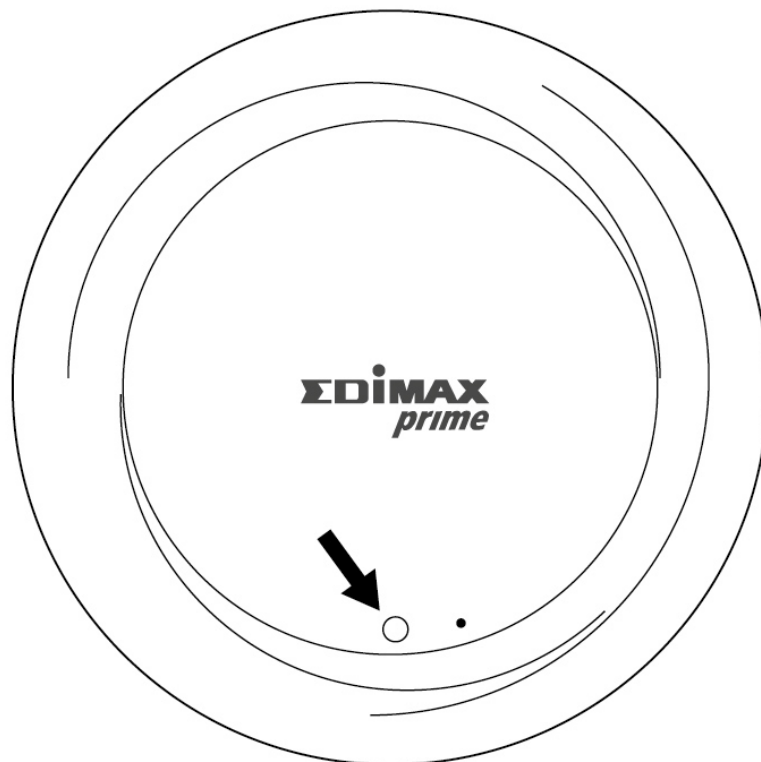

3. Designate one AP as the AP Controller which will manage all other connected APs (up to 16).

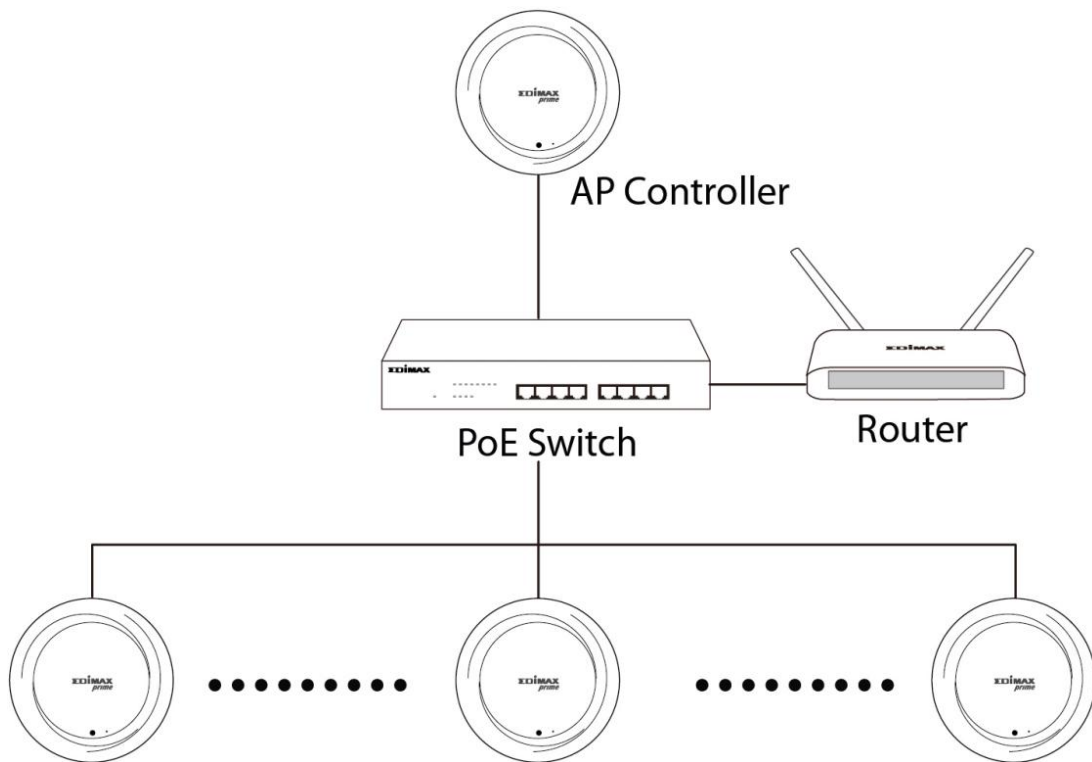

4. Connect a computer to the designated AP Controller using an Ethernet cable.



**Ensure you have the latest firmware from the Edimax website for your Edimax Pro products.**

5. Open a web browser and enter the AP Controller's IP address in the address field. (The default IP address is 192.168.2.2)

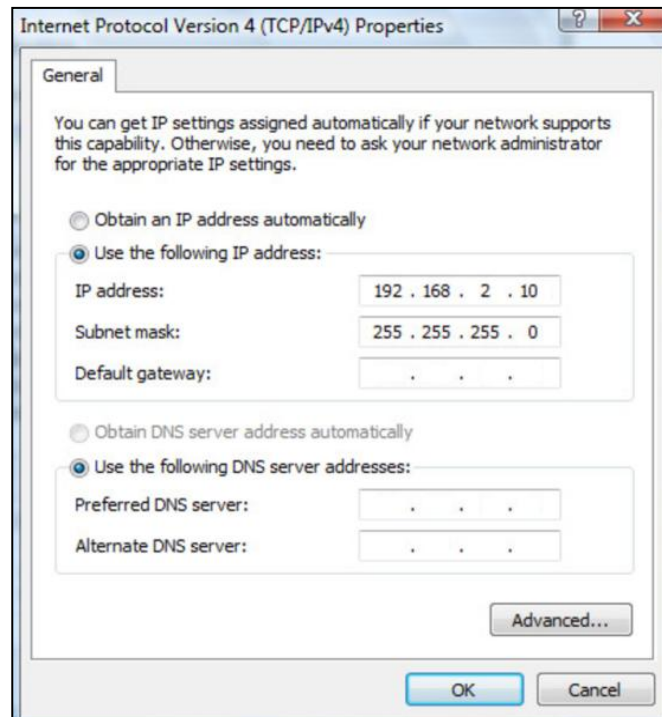

**Your computer's IP address must be in the same subnet as the AP Controller. Refer to the user manual for help.**



**If you changed the AP Controller's IP address, or if your router uses a DHCP server, ensure you enter the correct IP address. Refer to your router's settings.**

6. Enter the default Username / Password to login. (admin / 1234)  
You will arrive at the Edimax Pro NMS Dashboard.

7. Follow the steps below to change the operation Mode,

- i. Go to “Management”.
- ii. Tap “Operation Mode”.
- iii. Select “AP Controller Mode” from the drop down menu.

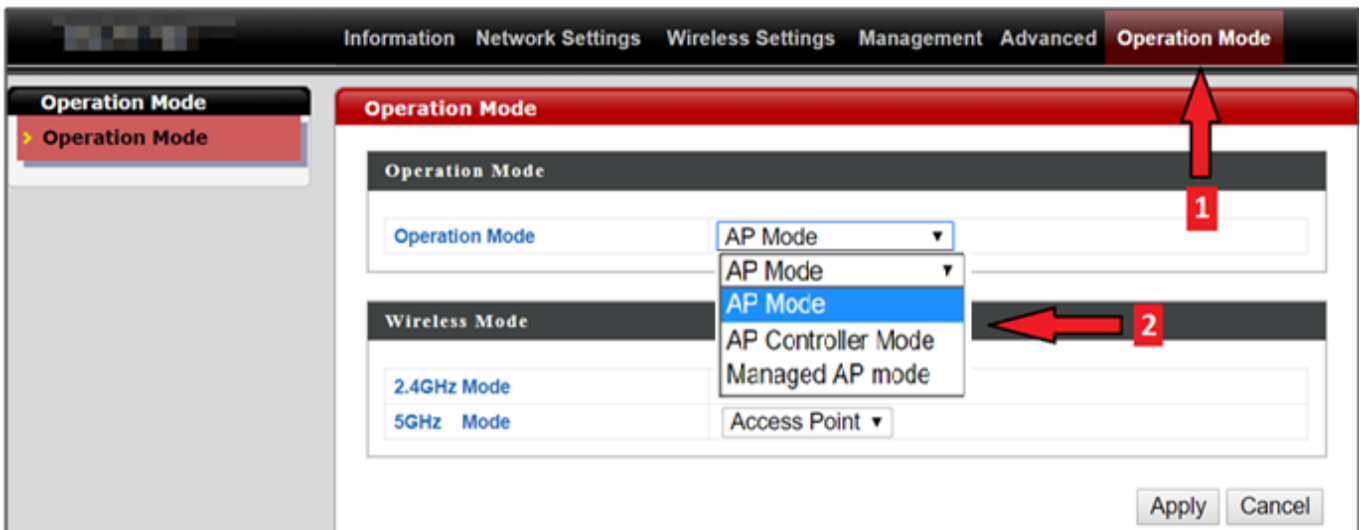

7. Click “Apply” to save the settings.

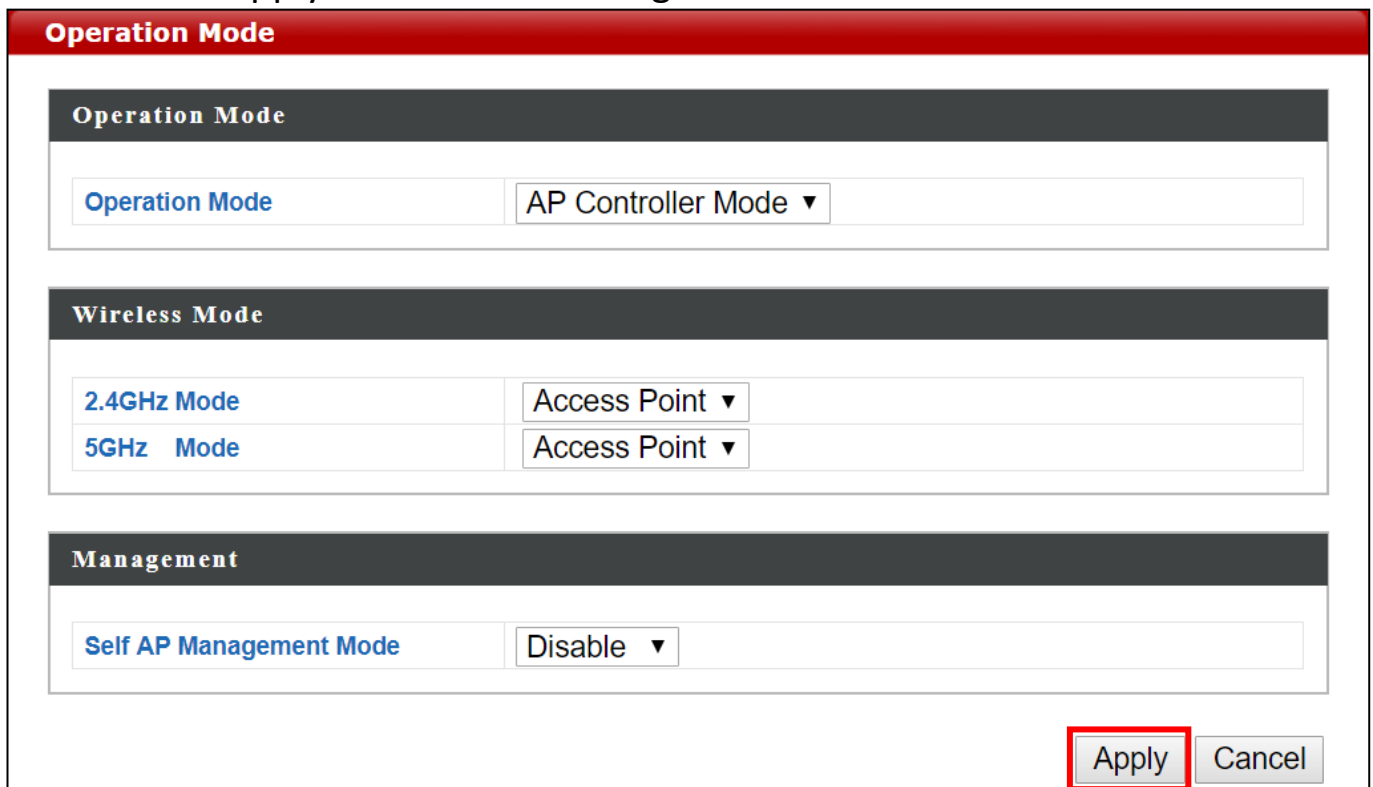

- Edimax Pro NMS includes a wizard to quickly setup the SSID & security for Managed APs. Click “Wizard” in the top right corner to begin.

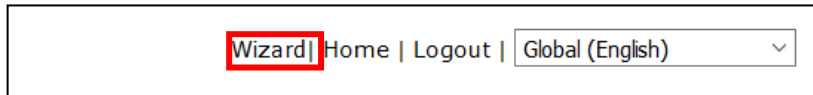

- Follow the instructions on-screen to complete Steps 1-6 and click “Finish” to save the settings.

**Step 1: Installation**

Before start, please power on the managed APs and plug into the same Ethernet network with this AP Controller.

This Setup Wizard will guide you through a basic procedure to configure AP Controller system.

Next >> Cancel

---

**Step 2: Local LAN-side IP Address**

IP Address Assignment	DHCP Client
IP Address	192.168.2.2
Subnet Mask	255.255.255.0
Default Gateway	From DHCP
Primary DNS Address	From DHCP
Secondary DNS Address	From DHCP

<< Back Next >> Cancel

---

**Step 3: Date and Time Settings**

**Local Time**

2012 Year Jan Month 1 Day

0 Hours 00 Minutes 00 Seconds

Acquire Current Time from Your PC

**NTP Time Server**

Use NTP  Enable

Auto Daylight Saving  Enable

Server Name User-Defined

Update Interval 24 (Hours)

**Time Zone**

Time Zone (GMT+08:00) Taipei, Taiwan

<< Back Next >> Cancel

---

**Step 4: Account to Manage This Device**

Administrator Name admin

Administrator Password (6-32 Characters)

(Confirm)

<< Back Next >> Cancel

Step 1 > 2 > 3 > 4 > **5** > 6 > Finish

**Select Free AP(s)**

Search   Match whole words

<input type="checkbox"/>	MAC Address	Device Name	Model	IP Address	Status
<input checked="" type="checkbox"/>	74-DA-38-1D-26-4E	AP74DA381D264E	WAP1200	192.168.2.101	<input type="radio"/>

**Managed AP(s)**

Search   Match whole words

MAC Address	Device Name	Model	IP Address	Status
No Access Point List				

Rescan << Back Next >> Cancel

Step 1 > 2 > 3 > 4 > 5 > **6** > Finish

**2.4GHz Settings**

SSID

Security Key

Guest Network  Enable  Disable

Guest SSID

Security Key

**5GHz Settings**

Clone 2.4GHz Settings

SSID

Security Key

Guest Network  Enable  Disable

Guest SSID

Security Key

<< Back Next >> Cancel

Step 1 > 2 > 3 > 4 > 5 > 6 > **Finish**

## Confirmation

**Management IP**

IP Address Assignment DHCP Client

**Date and Time**

Local Time 2012/01/01 00:00:00

Time Zone (GMT+08:00) Taipei, Taiwan

**Administrator Account**

Administrator Name admin

**Managed AP(s)**

MAC Address	Device Name	Model	IP Address	Status
74-DA-38-1D-26-4E	AP74DA381D264E	WAP1200	192.168.2.101	<input type="radio"/>

**2.4GHz Settings**

SSID

Security Key 12345678

**5GHz Settings**

SSID

Security Key 12345678

<< Back Finish Cancel



**If any of your Managed APs cannot be found, reset it to its factory default settings.**

- Your AP Controller & Managed APs should be fully functional. Use the top menu to navigate around Edimax Pro NMS.

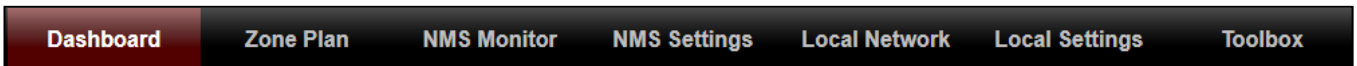

Use Dashboard, Zone Plan, NMS Monitor & NMS Settings to configure Managed APs.

Use Local Network & Local Settings to configure your AP Controller.

## VI-2. Webpage Layout - NMS

The top menu features 7 panels: Dashboard, Zone Plan, NMS Monitor, NMS Settings, Local Network, Local Settings & Toolbox.

### Dashboard:



The Dashboard panel displays an overview of your network and key system information, with quick links to access configuration options for Managed APs and Managed AP groups. Each panel can be refreshed, collapsed or moved according to your preference.

**APs Information**

1	0	1
Managed	Active	Offline
0		
Discovered		

**System Information**

Product Name	WAP1750
Host Name	AP801F02F1968A
MAC Address	80:1F:02:F1:96:8A
IP Address	192.168.2.2
Firmware Version	1.8.1
System Time	2012/01/01 19:53:06
Uptime	0 day 19:53:25
CPU Usage	3%
Memory / Cache Usage	83%

**Devices Information**

Device	Number
Access Points	1
Client Devices	0
Rogue Devices	0

**Managed AP**

Search:  Match whole words

Index	MAC Address	Device Name	Model	IP Address	2.4G Channel	5G Channel	Clients	2.4G Domain	5G Domain	Status	Action
1	74:DA:38:1D:26:4E	AP74DA381D264E	WAP1200	192.168.2.101	N/A	N/A	0	FCC	FCC		

**Managed AP Group**

Search:  Match whole words

Group Name	MAC Address	Device Name	Model	IP Address	Clients	Status	Action
System Default (0)							
Wizard AP Group 2 (1)							

**Active Clients**

Search:  Match whole words

Index	Client MAC Address	AP MAC Address	WLAN	User Name	Radio	Signal(%)	Connected Time	Idle Time	Tx(KB)	Rx(KB)	Vendor
Empty											

## Zone Plan:

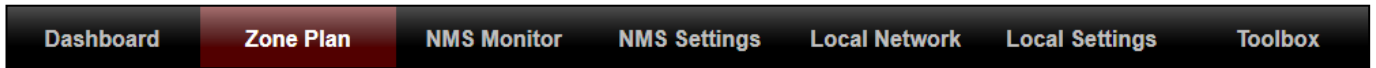

Zone Plan displays a customizable live map of Managed APs for a visual representation of your network coverage. Each AP icon can be moved around the map, and a background image can be uploaded for user-defined location profiles using NMS Settings → Zone Edit. Options can be configured using the menu on the right side and signal strength is displayed for each AP.

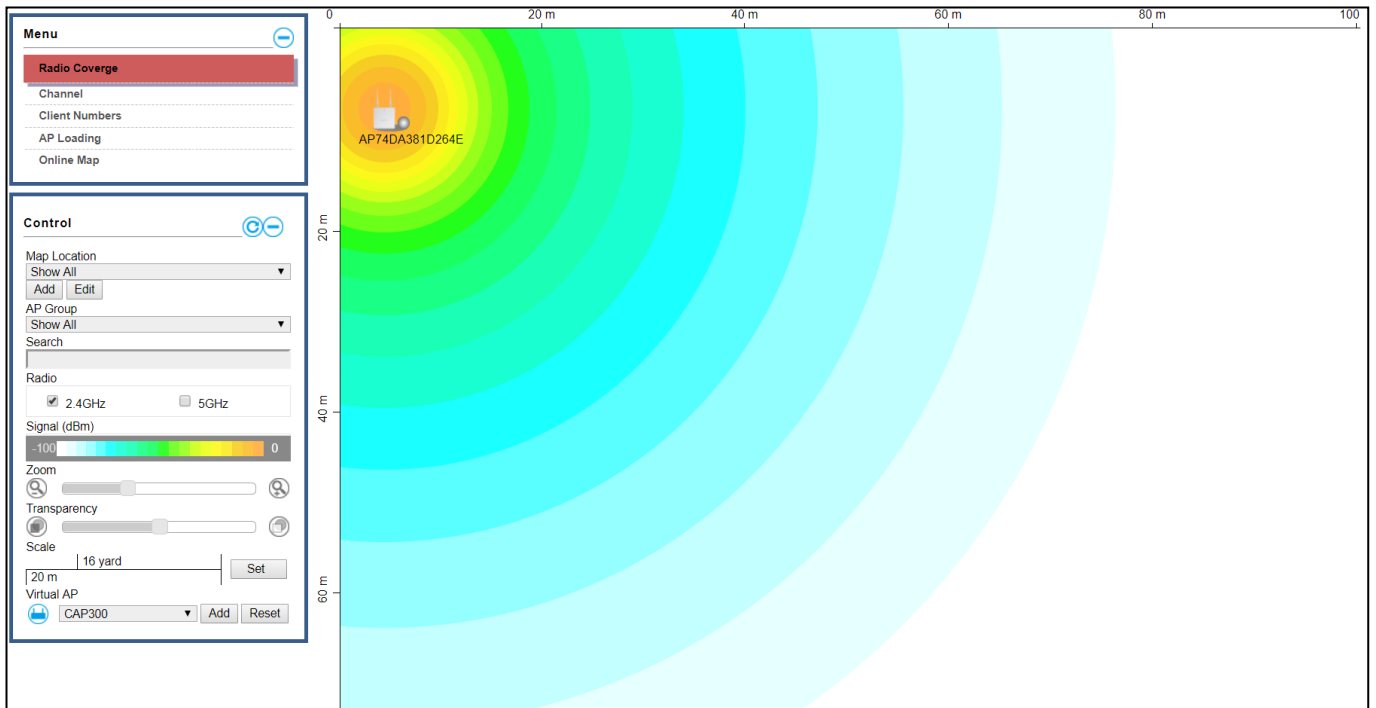

## NMS Monitor:



The NMS Monitor panel provides more detailed monitoring information about the AP Array than found on the Dashboard, grouped according to categories in the menu down the left side.

The screenshot shows the NMS Monitor interface. On the left is a sidebar menu with the following items: Access Point, Managed AP (highlighted), Managed AP Group, WLAN, Active WLAN, Active WLAN Group, Clients, Active Clients, Users, Active Users, Users Log, Rogue Devices, and Information (with sub-items: All Events/Activities, AP Monitoring, SSID Overview). The main content area is titled 'Managed AP' and features a search bar with a 'Match whole words' checkbox. Below the search bar is a table with the following data:

Index	MAC Address	Device Name	Model	IP Address	2.4G Channel	5G Channel	Clients	Status	Action
1	74:DA:38:1D:28:4E	AP74DA381D284E	WAP1200	192.168.2.101	N/A	N/A	0		

# NMS Settings:

NMS Settings provides extensive configuration options for the AP Array. You can manage each AP, assign APs into groups, manage WLAN, RADIUS & guest network settings as well as upgrade firmware across multiple APs. The Zone Plan can also be configured using “Zone Edit”.

**Access Point**

- > WLAN
- > RADIUS
- > Access Control
- > Guest Network
- > Users
- > Guest Portal
- > Zone Edit
- > Schedule
- > Smart Roaming
- > Device Monitoring
- > Firmware Upgrade
- > Advanced
  - System Security
  - Date and Time
  - Google Maps

**Access Point**

Search   Match whole words

<input type="checkbox"/>	Index ▲	MAC Address ▲	Device Name ▲	Model ▲	AP Group ▲	2.4G Channel ▲	5G Channel ▲	2.4G Tx Power ▲	5G Tx Power ▲	Status ▲	Action
<input type="checkbox"/>	1	74:DA:38:1D:26:4E	AP74DA381D264E	WAP1200	Wizard AP Group 2	N/A	N/A	N/A	N/A	<span style="color: gray;">●</span>	

Refresh   Edit   Delete Selected   Delete All

**Access Point Group**

Search   Match whole words

<input type="checkbox"/>	Group Name	AP Members	2.4G WLAN Profile	5G WLAN Profile	2.4G Guest Network Profile	5G Guest Network Profile	RADIUS Profile	Access Control Profile
<input type="checkbox"/>	System Default	0	Disabled	Disabled	Disabled	Disabled	Disabled	Disabled
<input type="checkbox"/>	Wizard AP Group 2	1	Wizard WLAN 2.4G Group 1	Wizard WLAN 5G Group 2	Disabled	Disabled	Disabled	Disabled

Add   Edit   Clone   Delete Selected   Delete All

**Access Point Settings**

Auto Approve  Enable  Disable

Apply

## Local Network:

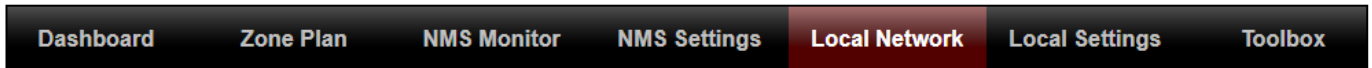

Local Network settings are for your AP Controller. You can configure the IP address and DHCP server of the AP Controller in addition to 2.4GHz & 5Ghz Wi-Fi and security, with WPS, RADIUS server, MAC filtering and WMM settings also available.

The screenshot shows the 'LAN-side IP Address' configuration page. On the left is a sidebar menu with categories like Network Settings, 2.4GHz 11bgn, 5GHz 11ac 11an, WPS, RADIUS, MAC Filter, WMM, and Schedule. The main content area is titled 'LAN-side IP Address' and contains the following fields:

Field	Value
IP Address Assignment	DHCP Client
IP Address	192.168.2.2
Subnet Mask	255.255.255.0
Default Gateway	From DHCP
Primary DNS Address	From DHCP 0.0.0.0
Secondary DNS Address	From DHCP 0.0.0.0

An 'Apply' button is located at the bottom right of the configuration area.

## Local Settings:



Local Settings are for your AP Controller. You can set the operation mode and view network settings (clients and logs) specifically for the AP Controller, as well as other management settings such as date/time, admin accounts, firmware and reset.

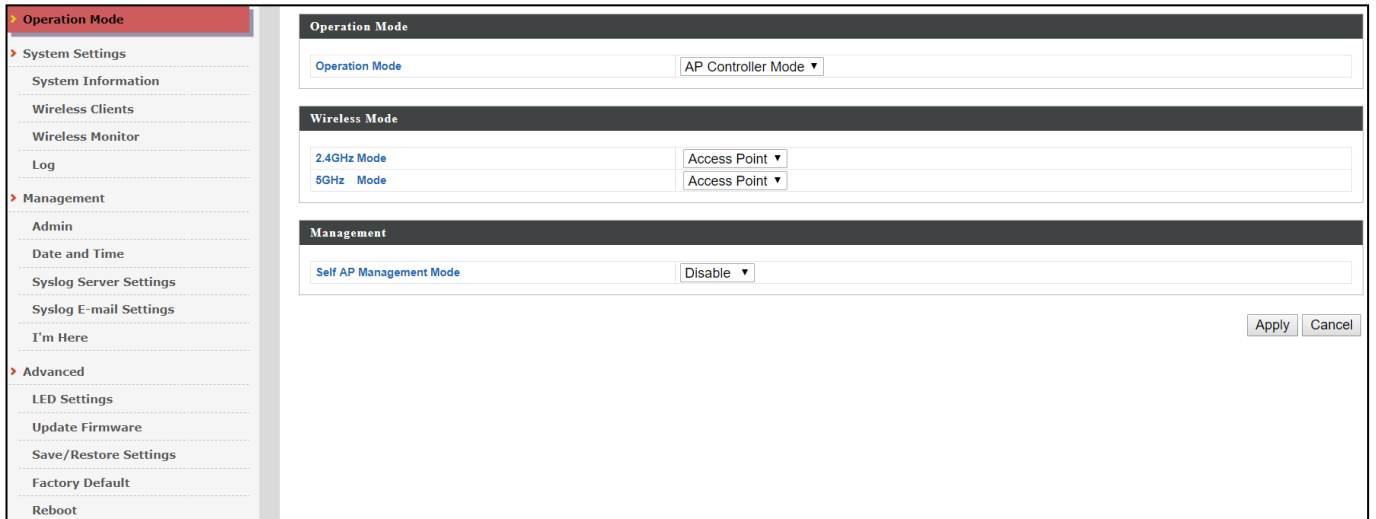

## Toolbox:

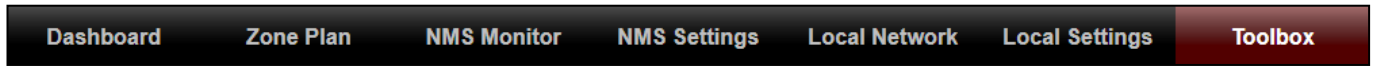

The Toolbox panel provides network diagnostic tools: *Ping*, *Traceroute*, and *IP Scan*.

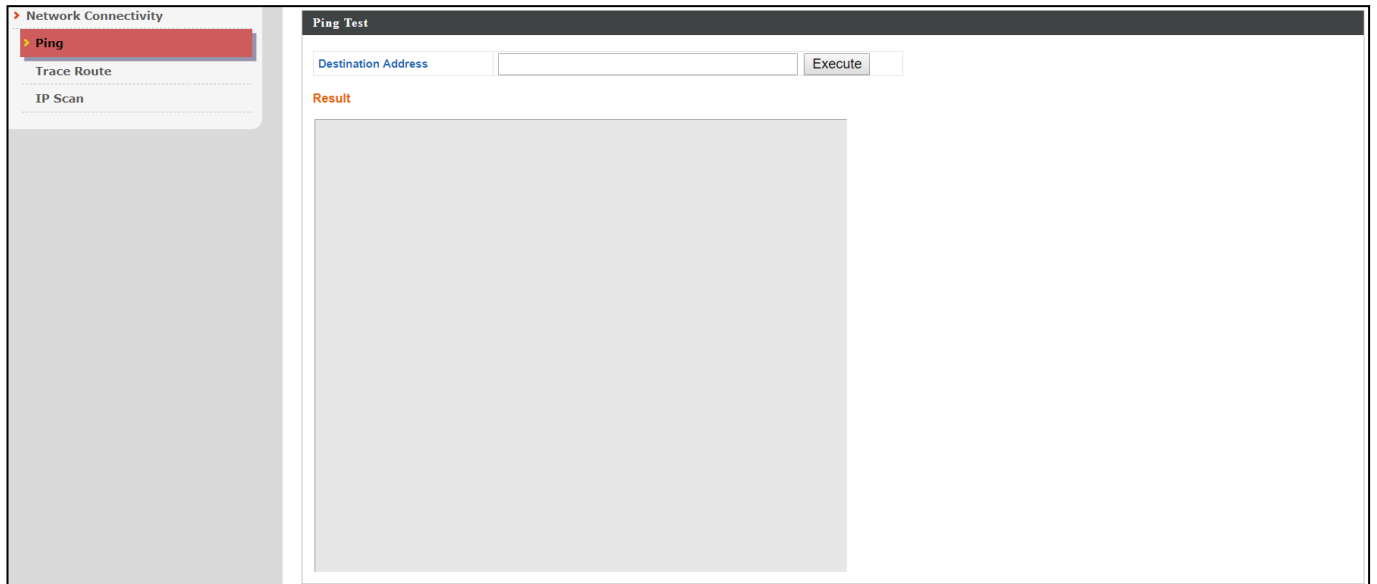

## VI-3. NMS Features

Descriptions of the functions of each main panel can be found below. When using Edimax NMS, click “Apply” to save changes:



 **It is recommended that you login to the AP Controller to make configurations to Managed APs.**

### Login:

1. Connect a computer to the designated AP Controller using an Ethernet cable:

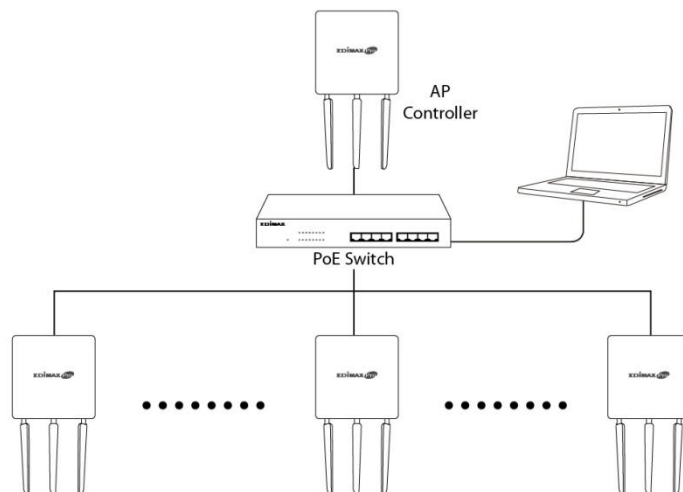

2. Open a web browser and enter the AP Controller’s IP address in the address field. The default IP address is 192.168.2.2.



 **Your computer’s IP address must be in the same subnet as the AP Controller.**



If you changed the AP Controller's IP address, or if your gateway/router uses a DHCP server, ensure you enter the correct IP address. Refer to your gateway/router's settings.



If a DHCP server is used in the network, it is advised to use your DHCP server's settings to assign the AP Controller a static IP address.

3. Enter the username & password to login. The default username & password are admin & 1234.

### Logout:

To logout from Edimax NMS, click "Logout" in the top right corner:

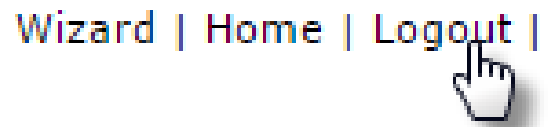
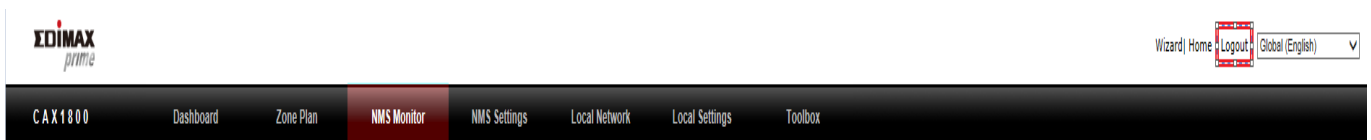

### Restart:

You can restart your AP Controller or any Managed AP using Edimax NMS. To restart your AP Controller go to Local Settings → Advanced → Reboot and click "Reboot".

*This will reboot the product. Your settings will not be changed. Click "Reboot" to reboot the product now.*



To restart Managed APs click the Restart icon for the specified AP on the Dashboard:



## VI-4. Dashboard



The dashboard displays an overview of your AP array:

Auto Refresh Time  1 minute  30 seconds  Disable

**APs Information**

1	0	1
Managed	Active	Offline
0		
Discovered		

**Managed AP**

Search   Match whole words

Index	MAC Address	Device Name	Model	IP Address	2.4G Channel	5G Channel	Clients	2.4G Domain	5G Domain	Status	Action
1	74:DA:38:1D:26:4E	AP74DA381D264E	WAP1200	192.168.2.101	N/A	N/A	0	FCC	FCC	<span style="color: grey;">●</span>	

**System Information**

Product Name	WAP1750
Host Name	AP801F02F1968A
MAC Address	80:1F:02:F1:96:8A
IP Address	192.168.2.2
Firmware Version	1.8.1
System Time	2012/01/01 19:53:06
Uptime	0 day 19:53:25
CPU Usage	<div style="width: 3%; background-color: blue;">3%</div>
Memory / Cache Usage	<div style="width: 63%; background-color: blue;">63%</div>

**Managed AP Group**

Search   Match whole words

Group Name	MAC Address	Device Name	Model	IP Address	Clients	Status	Action
System Default (0)							
Empty							
Wizard AP Group 2 (1)							

**Devices Information**

Device	Number
Access Points	1
Client Devices	0
Rogue Devices	0

**Active Clients**

Search   Match whole words

Index	Client MAC Address	AP MAC Address	WLAN	User Name	Radio	Signal(%)	Connected Time	Idle Time	Tx(KB)	Rx(KB)	Vendor
Empty											



Use the blue icons above to refresh or collapse each panel in the dashboard. Click and drag to move a panel to suit your preference. You can set the dashboard to auto-refresh every 1 minute, 30 seconds or disable auto-refresh:

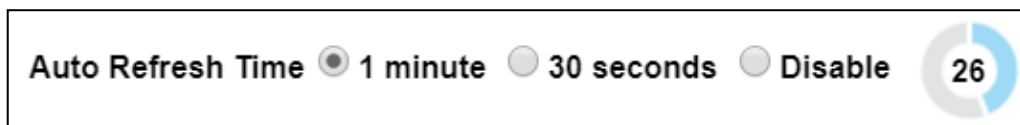

## i. System Information

System Information displays information about the AP Controller: Product Name (model), Host Name, MAC Address, IP Address, Firmware Version, System Time and Uptime (time the AP has been on).

System Information	
Product Name	WAP1750
Host Name	AP801F02F1968A
MAC Address	80:1F:02:F1:96:8A
IP Address	192.168.2.2
Firmware Version	1.8.1
System Time	2012/01/01 19:53:06
Uptime	0 day 19:53:25
CPU Usage	<div style="width: 3%;"><div style="width: 3%;"></div></div> 3%
Memory / Cache Usage	<div style="width: 63%;"><div style="width: 63%;"></div></div> 63%

## ii. Devices Information





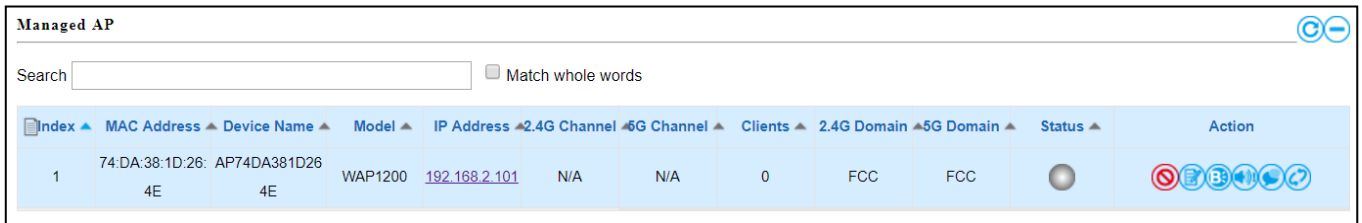

Devices Information is a summary of the number of all devices in the local network: APs, Clients Connected, and Rogue (unidentified) Devices.

Devices Information	
Device	Number
Access Points	1
Client Devices	0
Rogue Devices	0

### iii. Managed AP

This page displays information about the Managed APs in the local network: Index (reference number), MAC Address, Device Name, Model, IP Address, 2.4GHz & 5GHz Wireless Channel Number, No. of Clients connected to each AP, and Status (connected, connecting or disconnected).



Index	MAC Address	Device Name	Model	IP Address	2.4G Channel	5G Channel	Clients	2.4G Domain	5G Domain	Status	Action
1	74:DA:38:1D:26:4E	AP74DA381D264E	WAP1200	<a href="#">192.168.2.101</a>	N/A	N/A	0	FCC	FCC		    

The search function can be used to locate a specific Managed AP. Type in the search box and the list will update:

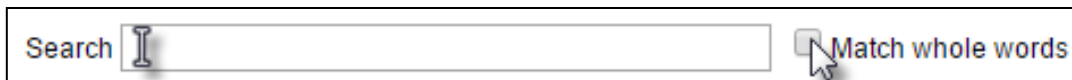

The Status icon displays *grey* (disconnected), *yellow* (connecting) or *green* (connected) for each Managed AP.

Each Managed AP has “Action” icons with the following functions:



#### 1. Disallow

Remove the Managed AP from the AP array and disable connectivity.

#### 2. Edit

Edit various settings for the Managed AP.

#### 3. Blink LED

The Managed AP’s LED will flash temporarily to help identify & locate the AP.

#### 4. Buzzer





The Managed AP's buzzer will sound temporarily to help identify/locate the AP.

#### 5. Network Connectivity

Go to the "Network Connectivity" panel to perform a ping or traceroute.

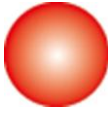
#### 6. Restart

Restarts the Managed AP.

Status Icons			
Icon	Color	Status	Definition
	Grey	Disconnected	Managed AP is disconnected. Please check the network connection and ensure the Managed AP is in the same IP subnet as the AP Controller.
	Red	Authentication Failed Or Incompatible NMS Version	System security must be the same for all APs in the AP array. Please check security settings.  All APs must have the same firmware version. Please use the AP Controller's firmware upgrade function.
	Orange	Configuring or Upgrading	Please wait while the Managed AP makes configurations or while the firmware is upgrading.
	Yellow	Connecting	Please wait while Managed AP is connecting.
	Green	Connected	Managed AP is connected.
	Blue	Waiting for Approval	Managed AP is waiting for approval. Note: Up to sixteen Managed APs are supported. Additional APs will have this status until an existing Managed AP is removed.

## iv. Managed AP Group

Managed APs can be grouped according to your requirements. Managed AP Group displays information about each Managed AP group in the local network: Group Name, MAC Address, Device Name, Model, IP Address, 2.4GHz & 5GHz Wireless Channel Number, No. of Clients connected to each AP, and Status (connected or disconnected).

To edit Managed AP Groups go to NMS Settings → AP.

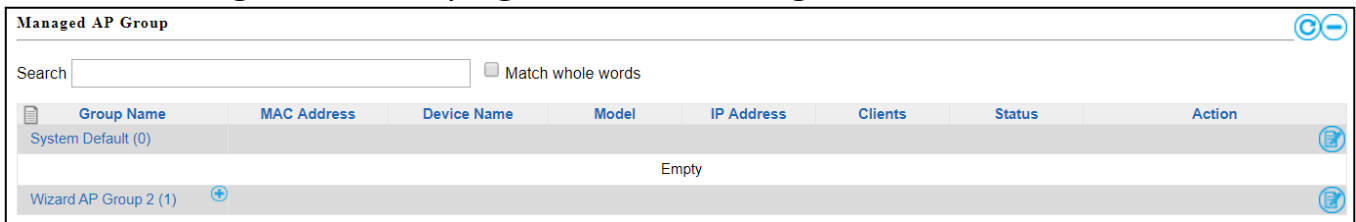

Group Name	MAC Address	Device Name	Model	IP Address	Clients	Status	Action
System Default (0)							
Empty							
Wizard AP Group 2 (1)							

The search function can be used to locate a specific Managed AP Group. Type in the search box and the list will update:

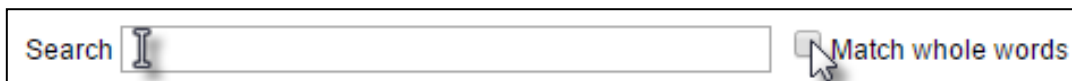

Search   Match whole words

The Status icon displays grey (disconnected), yellow (connecting) or green (connected) for each individual Managed AP.

Each Managed AP Group has “Action” icons with the following functions:



- 1. Disallow**

Remove the Managed AP Group from the AP array and disable connectivity.

- 2. Edit**

Edit various settings for the Managed AP Group.

- 3. Blink LED**

The LED of all Managed APs in the group will flash temporarily to help identify & locate the APs.

- 4. Buzzer**





The buzzer of all Managed APs in the group will sound temporarily to help identify & locate the APs.

- 5. Network Connectivity**

Go to the “Network Connectivity” panel to perform a ping or traceroute.

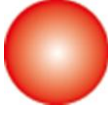
- 6. Restart**

Restarts all Managed APs in the group.

Status Icons			
Icon	Color	Status	Definition
	Grey	Disconnected	Managed AP is disconnected. Please check the network connection and ensure the Managed AP is in the same IP subnet as the AP Controller.
	Red	Authentication Failed Or Incompatible NMS Version	System security must be the same for all APs in the AP array. Please check security settings. All APs must have the same firmware version. Please use the AP Controller's firmware upgrade function.
	Orange	Configuring or Upgrading	Please wait while the Managed AP makes configurations or while the firmware is upgrading.
	Yellow	Connecting	Please wait while Managed AP is connecting.
	Green	Connected	Managed AP is connected.
	Blue	Waiting for Approval	Managed AP is waiting for approval. Note: Up to sixteen Managed APs are supported. Additional APs will have this status until an existing Managed AP is removed.

## v. Active Clients

Active Clients displays information about each client in the local network: Index (reference number), Client MAC Address, Device Name, Model, IP Address, 2.4GHz & 5GHz Wireless Channel Number, No. of Clients connected to each AP, and Status (on or off).



Index	Client MAC Address	AP MAC Address	WLAN	User Name	Radio	Signal(%)	Connected Time	Idle Time	Tx(KB)	Rx(KB)	Vendor
Empty											

The search function can be used to locate a specific client. Type in the search box and the list will update:



Search   Match whole words

## vi. Active Users

Active Users displays information about users currently connected to the AP Array: User Name, MAC Address, IP Address, SSID, Creator, Create Time, Expire Time, Usage Percentage, Vendor, Platform and Action.

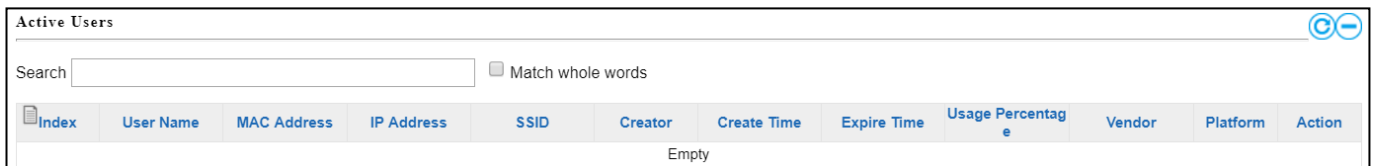

Index	User Name	MAC Address	IP Address	SSID	Creator	Create Time	Expire Time	Usage Percentage	Vendor	Platform	Action
Empty											

The search function can be used to locate a specific user. Type in the search box and the list will update:

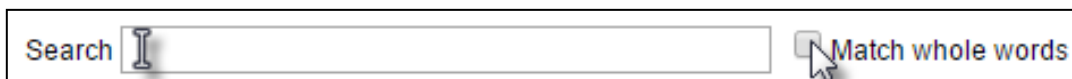

Search   Match whole words

## VI-5. Zone Plan



The Zone Plan can be fully customized to match your network environment. You can move the AP icons and select different location images (upload location images in NMS Settings → Zone Edit) to create a visual map of your AP array.

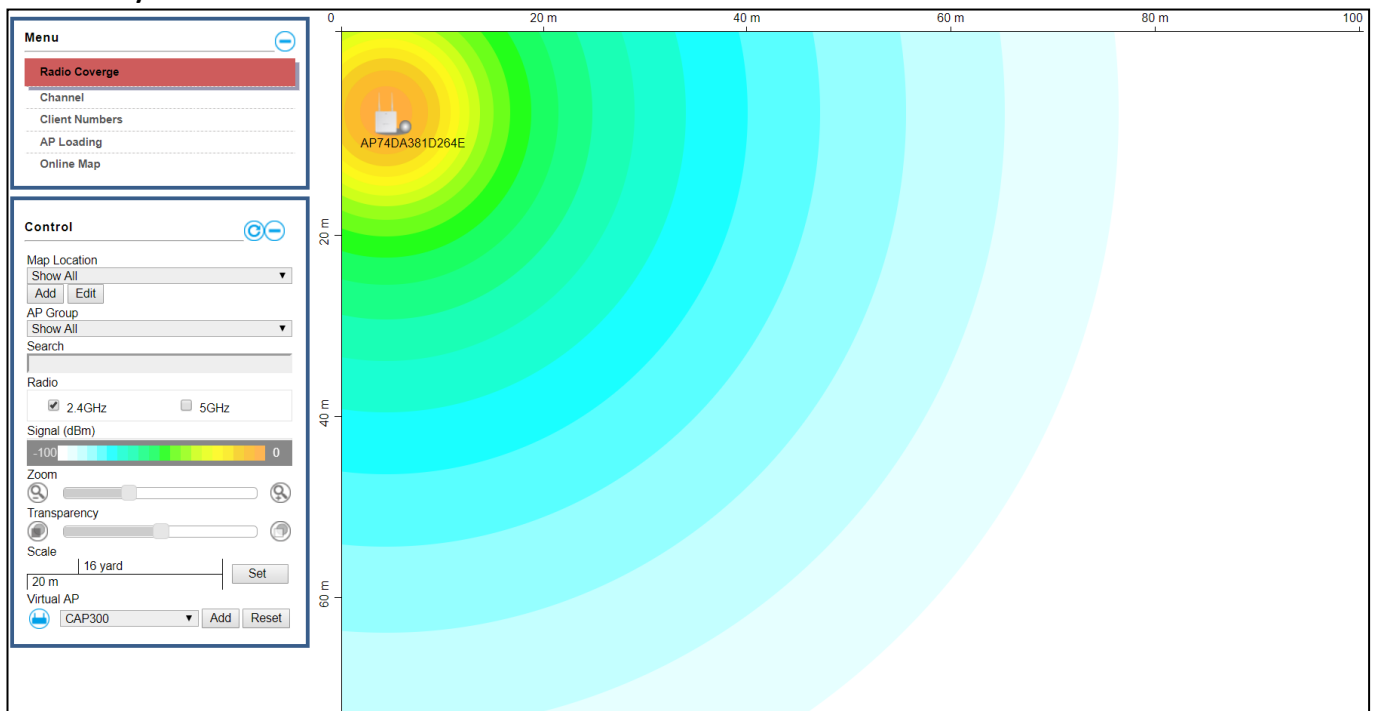

Use the menu on the left side to make adjustments and mouse-over an AP icon in the zone map to see more information. Click an AP icon in the zone map to select it and display action icons:

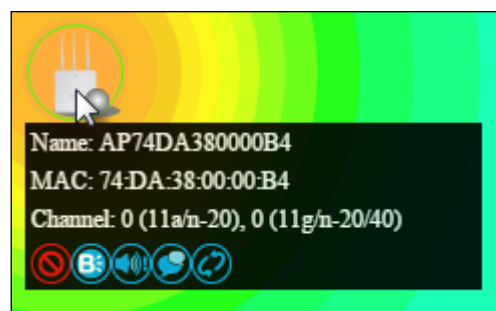

## i. Menu

Menu allows you to keep track of the APs' information. Select between *Radio Coverage*, *Channel*, *Client Numbers*, *AP Loading*, and *Online Map*. When an option is selected, the zone plan and Control section will change accordingly.

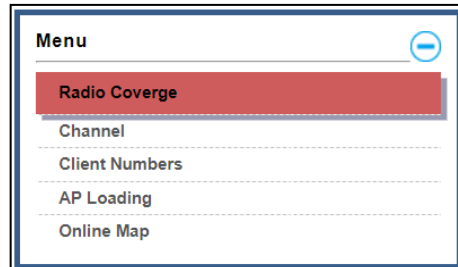

### Radio Coverage:

Below is displayed as Radio Coverage is selected:

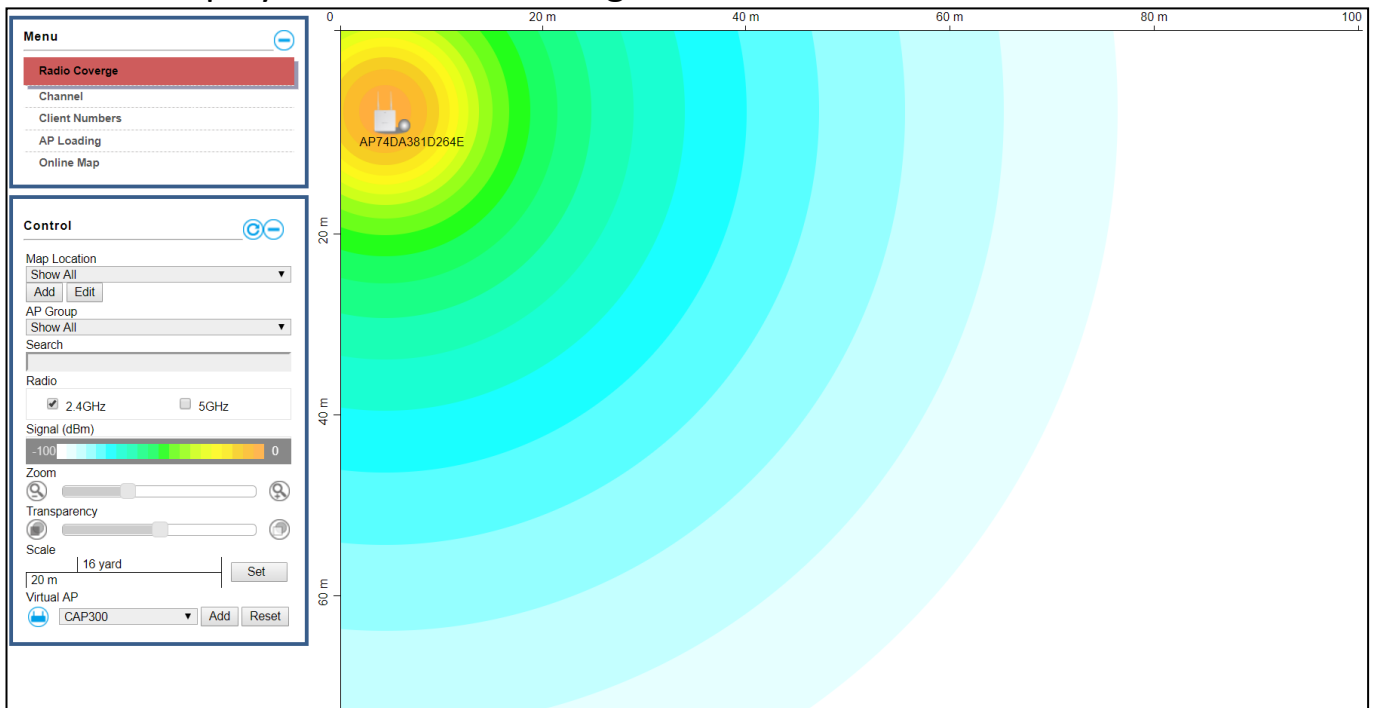

## Channel:

Below is displayed as Channel is selected:

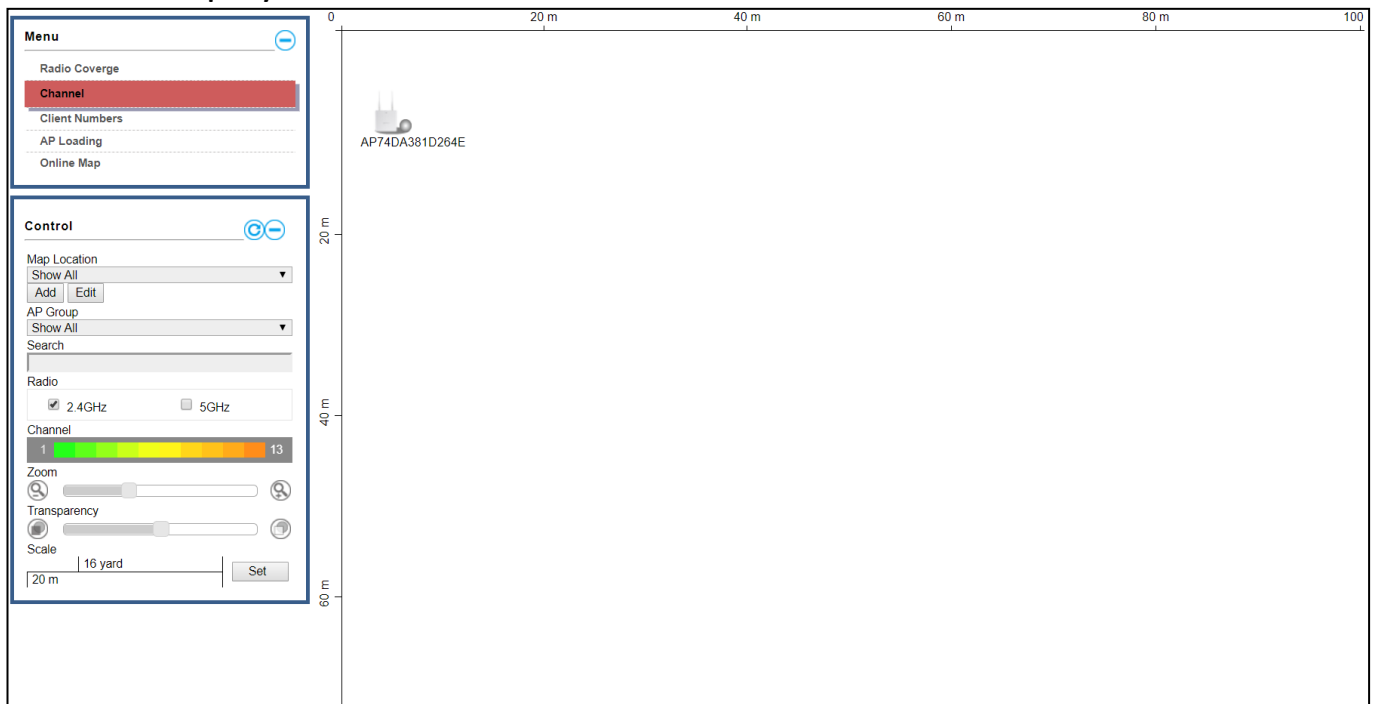

## Client Numbers:

Below is displayed as Client Numbers is selected:

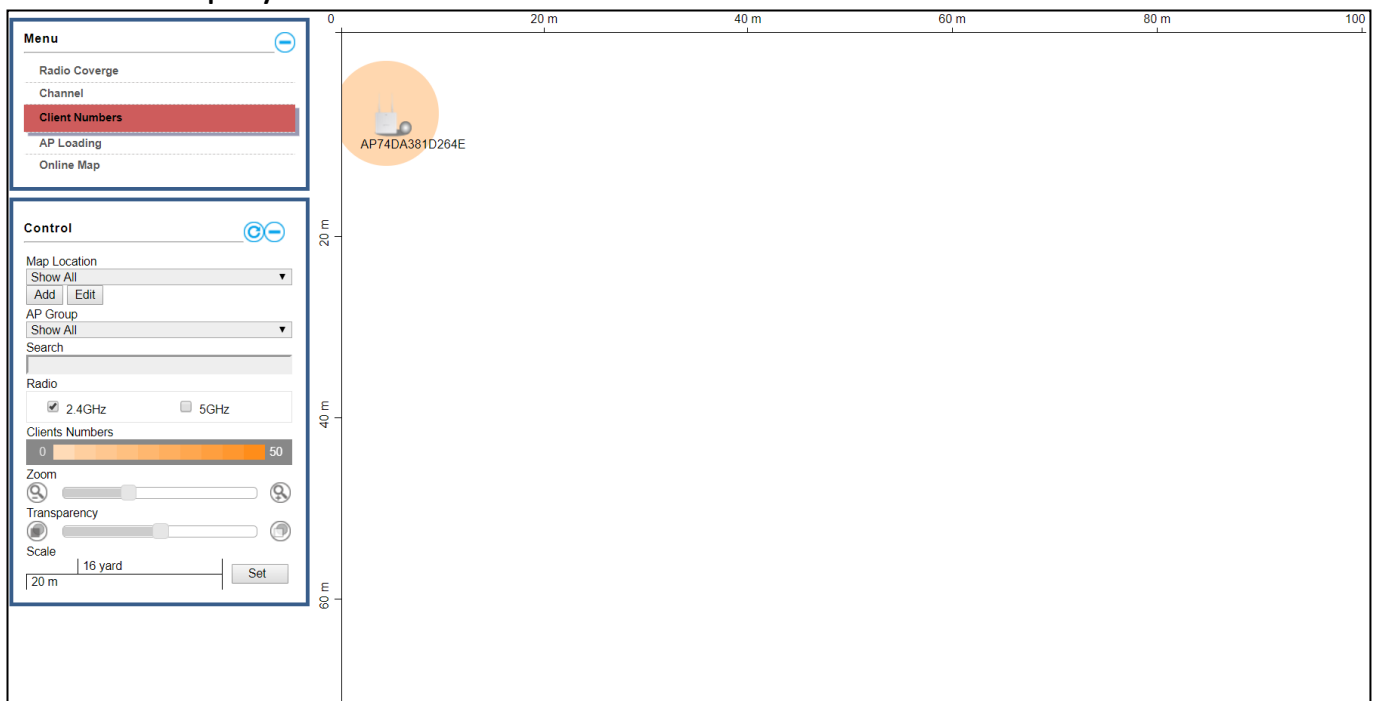

## AP Loading:

Below is displayed as AP Loading is selected:

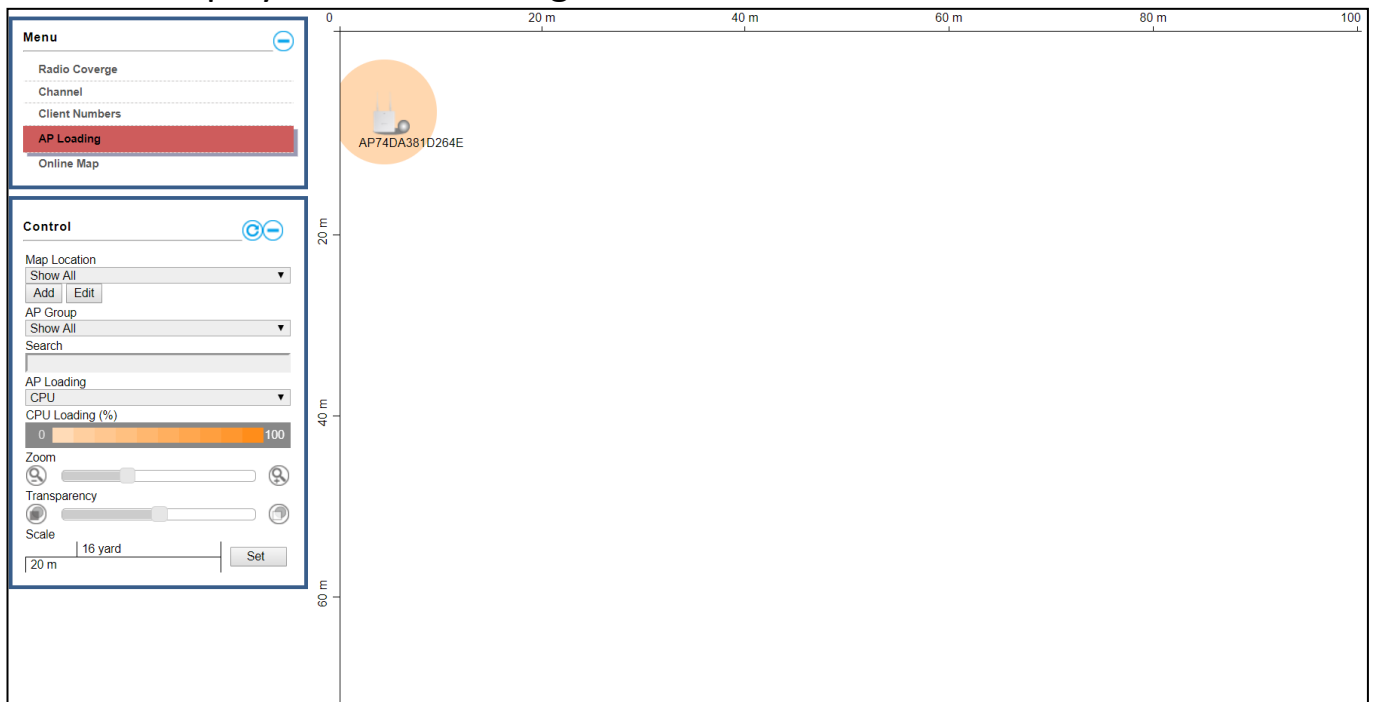

## Online Map:

When Online Map is selected, the message below is displayed:

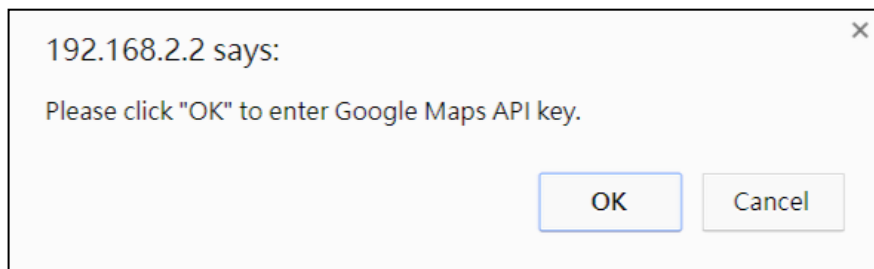

Click "OK" and the interface will bring you to the page shown below to allow API key entry:

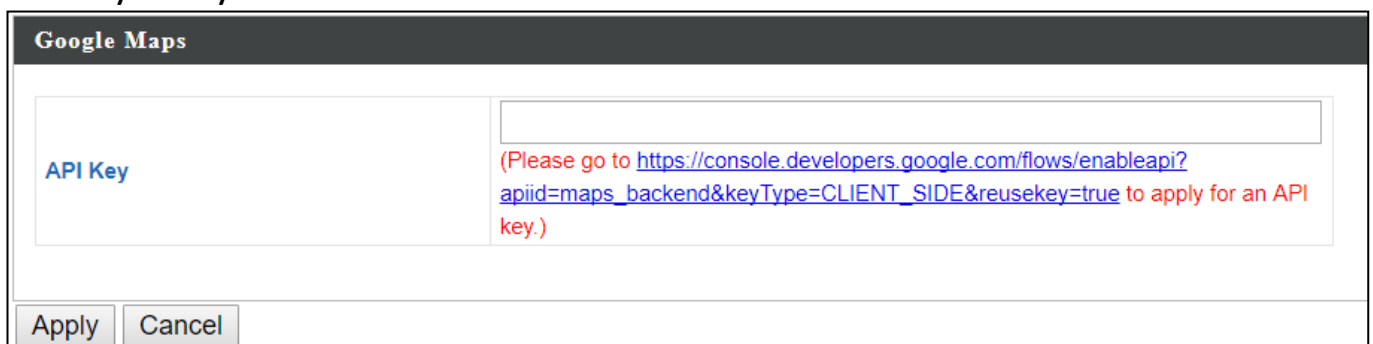

## ii. Control

The Control section will change according to the selection in the Menu section.

<b>Map Location</b>	Select a pre-defined location from the drop down menu. When you upload a location image in NMS Settings → Zone Edit, it will be available for selection here.
<b>AP Group</b>	You can select an AP Group to display in the zone map. Edit AP Groups in NMS Settings → AP.
<b>Search</b>	Use the search box to quickly locate an AP.
<b>Radio</b>	Use the checkboxes to display APs according to 2.4GHz or 5GHz wireless radio frequency.
<b>Signal</b>	When Radio Coverage is selected in Menu, signal strength is shown in the Control section below the “Radio” option. Signal strength chart displays the signal strength in dBm, and is also shown around each AP in the zone map.
<b>Channel</b>	When Channel is selected in Menu, channel is shown in the Control section below the “Radio” option.
<b>Client Numbers</b>	When Client Numbers is selected in Menu, client numbers is shown in the Control section below the “Radio” option.
<b>AP Loading</b>	When AP Loading is selected in Menu, AP loading is shown in the Control section below the “Search” option. Two options are available: “CPU” or “Traffic (Tx + Rx)”.
<b>CPU Loading</b>	This shows the CPU loading of the AP.
<b>Traffic (Tx + Rx)</b>	This shows the Traffic (Tx+Rx) loading.
<b>Zoom</b>	Use the slider to adjust the zoom level of the map.
<b>Transparency</b>	Use the slider to adjust the transparency of location images.
<b>Scale</b>	Zone map scale.
<b>Device/Number</b>	Displays number and type of devices in the zone map.

Click and drag an AP icon to move the icon around the zone map. The signal strength for each AP is displayed according to the “Signal” key in the menu on the right side:

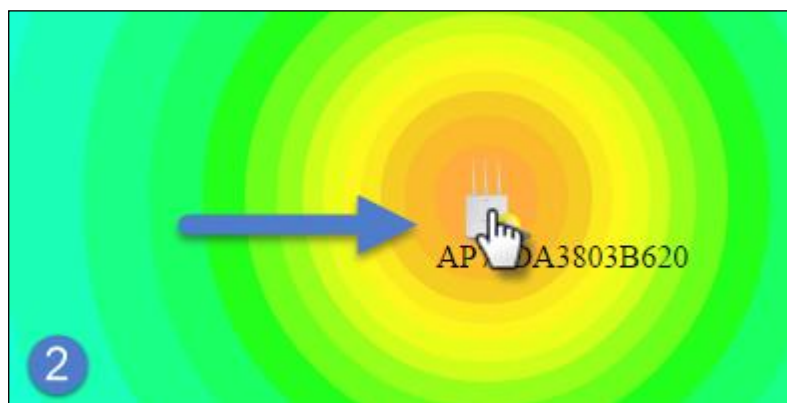
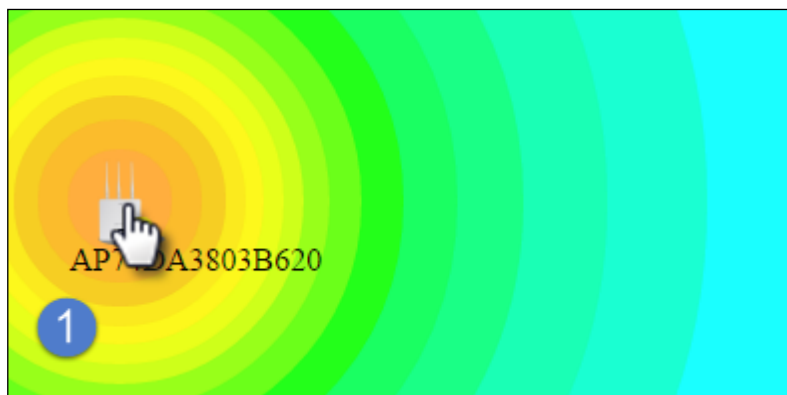

## VI-6. NMS Monitor



### i. AP

#### Managed AP:

Displays information about each Managed AP in the local network: Index (reference number), MAC Address, Device Name, Model, IP Address, 2.4GHz & 5GHz Wireless Channel Number, No. of Clients connected to each AP, and Status (connected, connecting or disconnected).



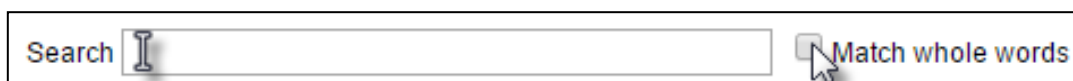

The screenshot shows a table titled "Managed AP" with a search bar and a "Match whole words" checkbox. The table has the following columns: Index, MAC Address, Device Name, Model, IP Address, 2.4G Channel, 5G Channel, Clients, Status, and Action. The first row contains the following data: Index 1, MAC Address 74:DA:38:1D:26:4E, Device Name AP74DA381D264E, Model WAP1200, IP Address 192.168.2.101, 2.4G Channel N/A, 5G Channel N/A, Clients 0, and Status (connected icon). The Action column contains several icons for management.

Index	MAC Address	Device Name	Model	IP Address	2.4G Channel	5G Channel	Clients	Status	Action
1	74:DA:38:1D:26:4E	AP74DA381D264E	WAP1200	192.168.2.101	N/A	N/A	0		

The search function can be used to locate a specific Managed AP. Type in the search box and the list will update:

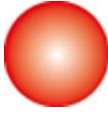

The Status icon displays the status of each Managed AP.

Status Icons			
Icon	Color	Status	Definition
	Grey	Disconnected	Managed AP is disconnected. Please check the network connection and ensure the Managed AP is in the same IP subnet as the AP Controller.
	Red	Authentication Failed Or Incompatible NMS Version	System security must be the same for all APs in the AP array. Please check security settings.  All APs must have the same firmware version. Please use the AP Controller's firmware upgrade function.
	Orange	Configuring or Upgrading	Please wait while the Managed AP makes configurations or while the firmware is upgrading.
	Yellow	Connecting	Please wait while Managed AP is connecting.
	Green	Connected	Managed AP is connected.
	Blue	Waiting for Approval	Managed AP is waiting for approval. Note: Up to sixteen Managed APs are supported. Additional APs will have this status until an existing Managed AP is removed.

Each Managed AP has “Action” icons with the following functions:



1. **Disallow**

Remove the Managed AP from the AP array and disable connectivity.

2. **Edit**

Edit various settings for the Managed AP.

3. **Blink LED**

The Managed AP's LED will flash temporarily to help identify & locate APs.

4. **Buzzer**

The Managed AP's buzzer will sound temporarily to help identify & locate APs.

5. **Network Connectivity**

Go to the "Network Connectivity" panel to perform a ping or traceroute.

6. **Restart**

Restarts the Managed AP.

## ii. Managed AP Group

Managed APs can be grouped according to your requirements. Managed AP Group displays information about each Managed AP group in the local network: Group Name, MAC Address, Device Name, Model, IP Address, 2.4GHz & 5GHz Wireless Channel Number, No. of Clients connected to each AP, and Status (connected or disconnected).

To edit Managed AP Groups go to NMS Settings → AP.

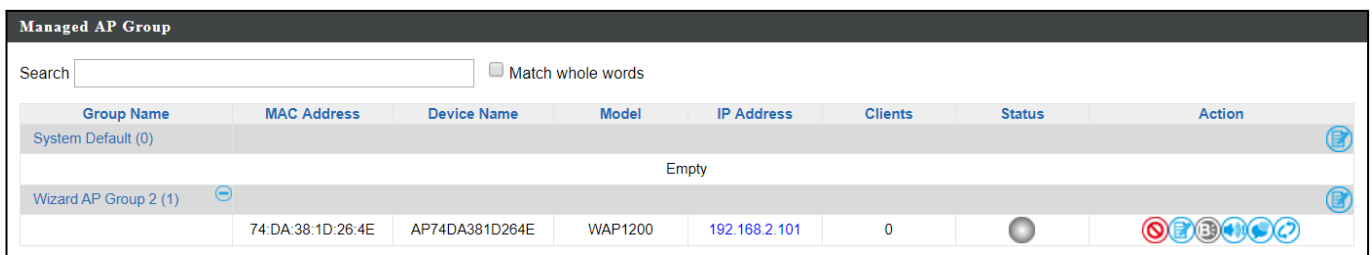



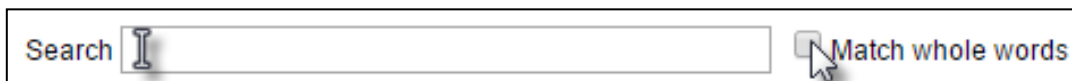

The screenshot shows the 'Managed AP Group' interface. At the top, there is a search bar with the text 'Search' and a checkbox labeled 'Match whole words'. Below the search bar is a table with the following columns: Group Name, MAC Address, Device Name, Model, IP Address, Clients, Status, and Action. The table contains two rows: 'System Default (0)' and 'Wizard AP Group 2 (1)'. The 'Wizard AP Group 2 (1)' row is expanded to show details: MAC Address: 74-DA-38-1D-26-4E, Device Name: AP74DA381D264E, Model: WAP1200, IP Address: 192.168.2.101, Clients: 0, and Status: a grey circle icon. The Action column for this row contains several icons: a red circle with a slash, a blue circle with a plus, a blue circle with a minus, a blue circle with a refresh, and a blue circle with a document.

Group Name	MAC Address	Device Name	Model	IP Address	Clients	Status	Action
System Default (0)							
Empty							
Wizard AP Group 2 (1)	74-DA-38-1D-26-4E	AP74DA381D264E	WAP1200	192.168.2.101	0	●	⊘ ⊕ ↻ 📄

The search function can be used to locate a specific Managed AP Group. Type in the search box and the list will update:

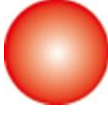

The Status icon displays the status of each Managed AP.

Status Icons			
Icon	Color	Status	Definition
	Grey	Disconnected	Managed AP is disconnected. Please check the network connection and ensure the Managed AP is in the same IP subnet as the AP Controller.
	Red	Authentication Failed Or Incompatible NMS Version	System security must be the same for all APs in the AP array. Please check security settings.  All APs must have the same firmware version. Please use the AP Controller's firmware upgrade function.
	Orange	Configuring or Upgrading	Please wait while the Managed AP makes configurations or while the firmware is upgrading.
	Yellow	Connecting	Please wait while Managed AP is connecting.
	Green	Connected	Managed AP is connected.
	Blue	Waiting for Approval	Managed AP is waiting for approval. Note: Up to sixteen Managed APs are supported. Additional APs will have this status until an existing Managed AP is removed.

Each Managed AP has “Action” icons with the following functions:



### **1. Disallow**

Remove the Managed AP Group from the AP array and disable connectivity.

### **2. Edit**

Edit various settings for the Managed AP Group.

### **3. Blink LED**

The LED of all Managed APs in the group will flash temporarily to help identify & locate the APs.

### **4. Buzzer**

The buzzer of all Managed APs in the group will sound temporarily to help identify & locate the APs.

### **5. Network Connectivity**

Go to the “Network Connectivity” panel to perform a ping or traceroute.

### **6. Restart**

Restarts all Managed APs in the group.

### iii. WLAN

#### Active WLAN:

Displays information about each SSID in the AP Array: Index (reference number), Name/SSID, VLAN ID, Authentication, Encryption, IP Address and Additional Authentication.

To configure encryption and VLANs for Managed APs go to NMS Settings → WLAN.

The search function can be used to locate a specific SSID. Type in the search box and the list will update:

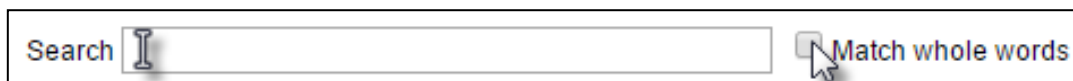

A search interface consisting of a text input field with a cursor, a checkbox labeled "Match whole words", and a mouse cursor pointing at the checkbox.

Active WLAN					
Index	Name/ESSID	VLAN ID	Authentication	Encryption	Additional Authentication
1	wap1750	1	WPA2PSK	AES	No additional authentication

## Active WLAN Group:

WLAN groups can be created according to your preference. Active WLAN Group displays information about WLAN group: *Group Name, Name/SSID, VLAN ID, Authentication, Encryption, IP Address and Additional Authentication.*

The search function can be used to locate a specific Active WLAN Group. Type in the search box and the list will update:

Search   Match whole words

Active WLAN Group					
Search	<input type="text"/>	<input type="checkbox"/> Match whole words			
Group Name	Name/ESSID	VLAN ID	Authentication	Encryption	Additional Authentication
Wizard WLAN 2.4G Group 1 (1)	wap1750	1	WPA2PSK	AES	No additional authentication
Wizard WLAN 5G Group 2 (1)	wap1750	1	WPA2PSK	AES	No additional authentication

## iv. Clients

### Active Clients:

Displays information about clients currently connected to the AP Array: Index (reference number), Client MAC Address, AP MAC Address, WLAN (SSID), Radio (2.4GHz or 5GHz), Signal Strength received by Client, Connected Time, Idle Time, Tx & Rx (Data transmitted and received by Client in KB), and the Vendor of the client device.

You can set or disable the auto-refresh time for the client list or click “Refresh” to manually refresh.

The search function can be used to locate a specific client. Type in the search box and the list will update:

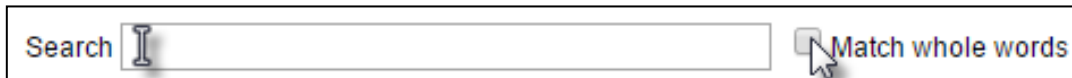

A search input field with the word "Search" on the left and a cursor inside the text box. To the right of the text box is a checkbox labeled "Match whole words".



The screenshot shows the "Clients" interface. At the top, there is a "Manual Refresh" button and a "Refresh" button. Below this is the "Active Clients" section, which includes a search input field and a "Match whole words" checkbox. A table with the following columns is visible: Index, Client MAC Address, AP MAC Address, WLAN, User Name, Radio, Signal(%), Connected Time, Idle Time, Tx(KB), Rx(KB), and Vendor. The table content is currently empty.

## v. Users

### Active Users:

Displays information about users currently connected.

Active Users												
Search <input type="text"/> <input type="checkbox"/> Match whole words												
Index	User Name	MAC Address	IP Address	SSID	Creator	Create Time	Expire Time	Usage Percentage	Traffic progress	Vendor	Platform Action	
Empty												

### Users Log:

Displays the log information about users currently connected.

Search <input type="text"/>	<input type="checkbox"/> Match whole words
-----------------------------	--

Users Log						
Search <input type="text"/> <input type="checkbox"/> Match whole words						
ID	Date and Time	Category	Severity	Users	Events/Activities	
Refresh						

## vi. Rogue Devices

Rogue AP detection can identify any unauthorized APs which may have been installed in the network.

Click “Start” to scan for rogue devices:



*Unknown Rogue Devices area displays information about rogue devices discovered during the scan: Index (reference number), Channel, SSID, MAC Address, Security, Signal Strength, Type, Vendor and Action.*

The search function can be used to locate a known rogue device. Type in the search box and the list will update:

Search   Match whole words

**Rogue Devices**

Scan

---

**Unknown Rogue Devices**

Search   Match whole words

Index	Channel	SSID	MAC Address	Security	Signal (%)	Type	Vendor	Action
No Rogue Device								

---

**Known Rogue Devices**

Search   Match whole words

## vii. Information

### All Events/Activities:

Displays a log of time-stamped events for each AP in the Array – use the drop down menu to select an AP and view the log.

Select AP:  ▼

All Events/Activities

- 74:DA:38:1D:26:4E
- 74:DA:38:1D:26:5A

Select AP:  ▼

All Events/Activities

Search   Match whole words

ID ▼	Date and Time	Severity ▲	Users ▲	Events/Activities
15	2012/01/01 00:01:10	Low	admin	Managed AP(74:DA:38:1D:26:4E) was disconnected
14	2012/01/01 00:07:01	Low	admin	Managed AP(74:DA:38:1D:26:4E) connect successfully
13	2012/01/01 00:00:21	Low	admin	Managed AP(74:DA:38:1D:26:4E) start NMS WTP service successfully
12	2012/01/01 00:00:55	Low	admin	Managed AP(74:DA:38:1D:26:4E) start NMS WTP service successfully
11	2012/01/01 00:01:05	Low	admin	Managed AP(74:DA:38:1D:26:4E) start NMS WTP service successfully
10	2012/01/01 00:07:40	Low	admin	Managed AP(74:DA:38:1D:26:4E) was disconnected
9	2012/01/01 00:09:57	Low	admin	Managed AP(74:DA:38:1D:26:4E) connect successfully
8	2012/01/01 00:00:24	Low	admin	Managed AP(74:DA:38:1D:26:4E) start NMS WTP service successfully
7	2012/01/01 00:10:31	Low	admin	Managed AP(74:DA:38:1D:26:4E) was disconnected
6	2012/01/01 00:12:15	Low	admin	Managed AP(74:DA:38:1D:26:4E) connect successfully
5	2012/01/01 00:13:58	Low	admin	Managed AP(74:DA:38:1D:26:4E) was disconnected
4	2012/01/01 00:14:31	Low	admin	Managed AP(74:DA:38:1D:26:4E) connect successfully
3	2012/01/01 00:00:22	Low	admin	Managed AP(74:DA:38:1D:26:4E) start NMS WTP service successfully
2	2012/01/01 00:00:55	Low	admin	Managed AP(74:DA:38:1D:26:4E) start NMS WTP service successfully
1	2012/01/01 00:00:23	Low	admin	Managed AP(74:DA:38:1D:26:4E) start NMS WTP service successfully

## AP Monitoring:

Displays graphical monitoring information about APs in the Array for 2.4GHz & 5GHz: *Traffic Tx (data transmitted in MB), Traffic Rx (data received in MB), No. of Clients, Wireless Channel, Tx Power (wireless radio power), CPU Usage and Memory Usage.*

Use the drop down menus to select an AP and date.

You can set or disable the auto-refresh time for the data:

Auto Refresh Time :  1 minute  30 seconds  Disable



Select AP: 74:DA:38:1D:26:4E   

Select Date: No Data    **Managed AP will analysis the system every hour. When the statistics information is ready, AP Controller will retrieve and display. Please wait for a moment.**

Managed AP Information	Traffic Tx
<b>Model Name</b> WAP1200 <b>Model Image</b> <b>Host Name</b> AP74DA381D264E <b>MAC Address</b> 74:DA:38:1D:26:4E <b>IP Address</b> 192.168.2.101 <b>Firmware Version</b> 1.8.1	<input checked="" type="checkbox"/> Traffic Tx <input type="checkbox"/> Client Number <input type="checkbox"/> Channel <input type="checkbox"/> Tx Power <input type="checkbox"/> CPU Usage <input type="checkbox"/> Memory / Cache Usage

**WLAN Information**

2.4G	
WLAN Groups	Wizard WLAN 2.4G Group 1
WLAN member list	wap1750

5G	
WLAN Groups	Wizard WLAN 5G Group 2
WLAN member list	wap1750

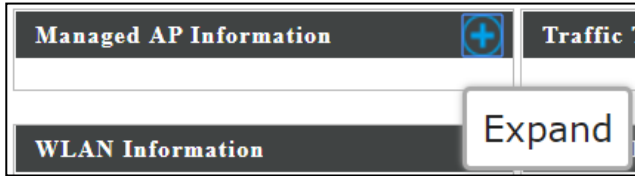

Select AP:

Select Date:  **Managed AP will analysis the system every hour. When the statistics information is ready, AP Controller will retrieve and display. Please wait for a moment.**

Managed AP Information	Traffic Tx												
<table border="1"> <tr> <td><b>Model Name</b></td> <td>WAP1200</td> </tr> <tr> <td><b>Model Image</b></td> <td></td> </tr> <tr> <td><b>Host Name</b></td> <td>AP74DA381D264E</td> </tr> <tr> <td><b>MAC Address</b></td> <td>74:DA:38:1D:26:4E</td> </tr> <tr> <td><b>IP Address</b></td> <td>192.168.2.101</td> </tr> <tr> <td><b>Firmware Version</b></td> <td>1.8.1</td> </tr> </table>	<b>Model Name</b>	WAP1200	<b>Model Image</b>		<b>Host Name</b>	AP74DA381D264E	<b>MAC Address</b>	74:DA:38:1D:26:4E	<b>IP Address</b>	192.168.2.101	<b>Firmware Version</b>	1.8.1	
<b>Model Name</b>	WAP1200												
<b>Model Image</b>													
<b>Host Name</b>	AP74DA381D264E												
<b>MAC Address</b>	74:DA:38:1D:26:4E												
<b>IP Address</b>	192.168.2.101												
<b>Firmware Version</b>	1.8.1												
	<b>Traffic RX</b>												
	<b>Client Number</b>												
	<b>Channel</b>												
	<b>Tx Power</b>												
	<b>CPU Usage</b>												
	<b>Memory / Cache Usage</b>												

WLAN Information
<b>2.4G</b>
WLAN Groups: Wizard WLAN 2.4G Group 1
WLAN member list: wap1750
<b>5G</b>
WLAN Groups: Wizard WLAN 5G Group 2
WLAN member list: wap1750

## SSID Overview:

Displays graphical monitoring information about APs in the Array for 2.4GHz & 5GHz.

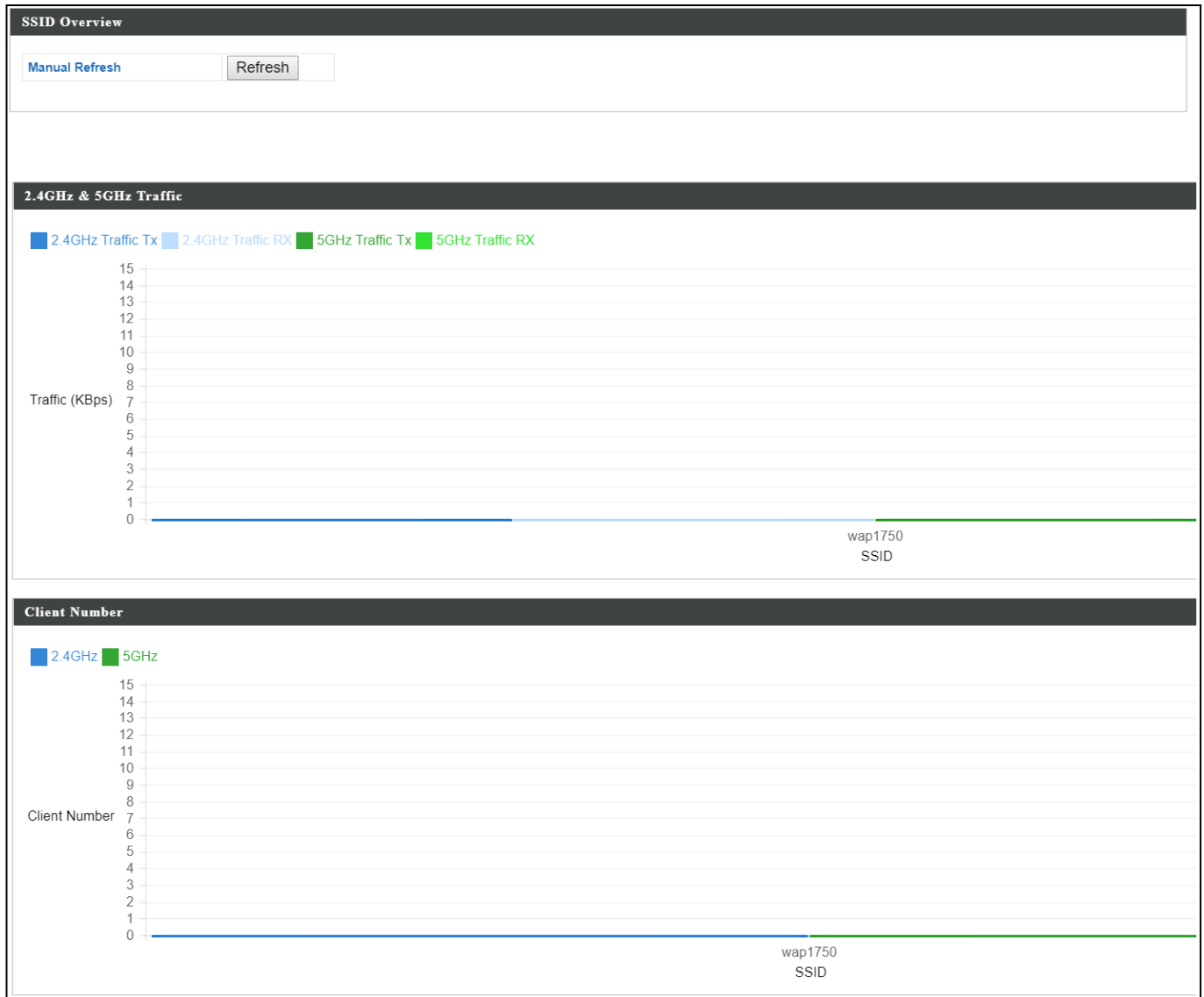

## VI-7. NMS Settings



### i. Access Point

Displays information about each AP and AP group in the local network and allows you to edit APs and edit or add AP groups.

The search function can be used to locate an AP or AP group. Type in the search box and the list will update:

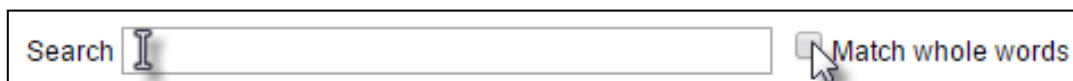

**Access Point**

Search   Match whole words

<input type="checkbox"/>	Index ▲	MAC Address ▲	Device Name ▲	Model ▲	AP Group ▲	2.4G Channel ▲	5G Channel ▲	2.4G Tx Power ▲	5G Tx Power ▲	Status ▲	Action
<input type="checkbox"/>	1	74:DA:38:1D:26:4E	AP74DA381D264E	WAP1200	Wizard AP Group 2	11	36	Full (14dbm)	Full (16dbm)	<span style="color: green;">●</span>	
<input type="checkbox"/>	2	74:DA:38:1D:26:5A	AP74DA381D265A	WAP1200	System Default	N/A	N/A	N/A	N/A	<span style="color: green;">●</span>	

---

**Access Point Group**

Search   Match whole words

<input type="checkbox"/>	Group Name	AP Members	2.4G WLAN Profile	5G WLAN Profile	2.4G Guest Network Profile	5G Guest Network Profile	RADIUS Profile	Access Control Profile
<input type="checkbox"/>	System Default	1	Disabled	Disabled	Disabled	Disabled	Disabled	Disabled
<input type="checkbox"/>	Wizard AP Group 2	1	Wizard WLAN 2.4G Group 1	Wizard WLAN 5G Group 2	Disabled	Disabled	Disabled	Disabled

---

**Access Point Settings**

Auto Approve  Enable  Disable

The Status icon displays *grey* (disconnected), *red* (authentication failed/incompatible NMS version), *orange* (upgrading firmware), *yellow* (connecting), *green* (connected) or *blue* (waiting for approval) for each individual Managed AP.

The “Action” icons enable you to allow or disallow an AP:

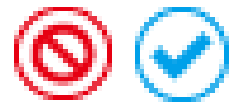

Select an AP or AP group using the check-boxes and click “Edit” to make configurations, or click “Add” to add a new AP group:



The AP Settings panel can enable or disable Auto Approve for all Managed APs. When enabled, Managed APs will automatically join the AP Array with the Controller AP. When disabled, Managed APs must be manually approved to join the AP Array with the Controller AP.

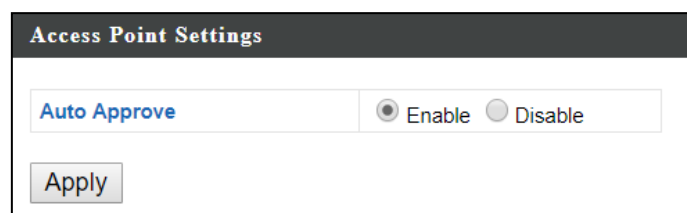

AP Settings	
<b>Auto Approve</b>	Enable or disable Auto Approve for all Managed APs.

To manually approve a Managed AP, use the *allow* “Action” icon for the specified AP:

### Edit AP:

Configure your selected AP on your LAN. You can set the AP as a DHCP client or specify a static IP address for your AP, and assign the AP to an AP group, as well as edit 2.4GHz & 5GHz wireless radio settings. Event log is displayed at the bottom of the page.

You can also use Profile Settings to assign the AP to WLAN, Guest Network, RADIUS and Access Control groups independently from AP Group settings. Click “Save” to save the settings. Click “Cancel” to forfeit the changes. Click “Save and Apply” to save and apply the settings.

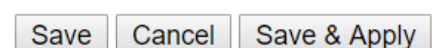

## Edit Basic Settings:

When “Override Group Setting” is checked, options/fields will turn white to allow adjustments.

**Override Group Setting**

Basic Settings	
Name	AP74DA381D264E
Description	
MAC Address	74:DA:38:1D:26:4E
AP Group	Wizard AP Group 2 ▼
IP Address Assignment	<input type="checkbox"/> Override Group Setting DHCP Client ▼
IP Address	192.168.2.101
Subnet Mask	255.255.255.0
Default Gateway	From DHCP ▼ 0.0.0.0
Primary DNS	User-Defined ▼
Secondary DNS	User-Defined ▼
IGMP Snooping	<input type="checkbox"/> Override Group Setting Disable ▼
Location Type	Indoor ▼

IP Address Assignment	<input checked="" type="checkbox"/> <b>Override Group Setting</b> DHCP Client ▼
IP Address	192.168.2.101
Subnet Mask	255.255.255.0
Default Gateway	From DHCP ▼ 0.0.0.0
Primary DNS	User-Defined ▼
Secondary DNS	User-Defined ▼
IGMP Snooping	<input checked="" type="checkbox"/> <b>Override Group Setting</b> Disable ▼
Location Type	Indoor ▼

Basic Settings	
<b>Name</b>	Edit the AP name. The default name is AP + MAC address.
<b>Description</b>	Enter a description of the AP for reference e.g. 2 <sup>nd</sup> Floor Office.
<b>MAC Address</b>	Displays MAC address.
<b>AP Group</b>	Use the drop down menu to assign the AP to an AP Group.
<b>IP Address Assignment</b>	Select “DHCP Client” for your AP to be assigned a dynamic IP address from your router’s DHCP server, or select “Static IP” to manually specify a static/fixed IP address for your AP (below). Check the box “Override Group Setting” if the AP is a member of an AP Group and you wish to use a different setting than the AP Group setting.
<b>IP Address</b>	Specify the IP address here. This IP address will be assigned to

	your AP and will replace the default IP address.
<b>Subnet Mask</b>	Specify a subnet mask. The default value is 255.255.255.0
<b>Default Gateway</b>	For DHCP users, select “From DHCP” to get default gateway from your DHCP server or “User-Defined” to enter a gateway manually. For static IP users, the default value is blank.
<b>Primary DNS</b>	DHCP users can select “From DHCP” to get primary DNS server’s IP address from DHCP or “User-Defined” to manually enter a value. For static IP users, the default value is blank.
<b>Secondary DNS</b>	DHCP users can select “From DHCP” to get secondary DNS server’s IP address from DHCP or “User-Defined” to manually enter a value. For static IP users, the default value is blank.
<b>IGMP Snooping</b>	Enable / Disable the IGMP Snooping function. IGMP snooping is the process of listening to Internet Group Management Protocol (IGMP) network traffic.
<b>Location Type</b>	Select the location of the AP (indoor or outdoor).

### Edit Web Account Settings:

**Web Account Settings**

Override Group Setting

Administrator Name	admin	
Administrator Password	1234	(6-32Characters)

When “Override Group Setting” is checked, options/fields will turn white to allow adjustments.

**Override Group Setting**

### Edit VLAN Settings:

**VLAN Settings**

Wired LAN Port	VLAN Mode	VLAN ID
Wired Port(#1)	<input type="checkbox"/> Override Group Setting Untagged Port	<input type="checkbox"/> Override Group Setting 1
Wired Port(#2)	<input type="checkbox"/> Override Group Setting Untagged Port	<input type="checkbox"/> Override Group Setting 1
Management VLAN ID	<input type="checkbox"/> Override Group Setting	1

When “Override Group Setting” is checked, options/fields will turn white to allow adjustments.

**Override Group Setting**

# Edit Radio Settings:

**Radio Settings**

Radio B/G/N (2.4 GHz)		Radio A/N/AC (5.0 GHz)	
Wireless	<input type="checkbox"/> Override Group Setting Enable	<input type="checkbox"/> Override Group Setting Enable	
Band	<input type="checkbox"/> Override Group Setting 11b/g/n	<input type="checkbox"/> Override Group Setting 11a/n/ac	
Auto Pilot	<input type="checkbox"/> Override Group Setting Disable <small>Please set AP position on the Zone Plan first.</small>	<input type="checkbox"/> Override Group Setting Disable <small>Please set AP position on the Zone Plan first.</small>	
Auto Pilot Sensitivity	<input type="checkbox"/> Override Group Setting Low	<input type="checkbox"/> Override Group Setting Low	
Auto Pilot Range	<input type="checkbox"/> Override Group Setting Ch 1 - 11	<input type="checkbox"/> Override Group Setting Band 1	
Auto Pilot Interval	<input type="checkbox"/> Override Group Setting Half day <input type="checkbox"/> Change channel even if clients are connected	<input type="checkbox"/> Override Group Setting Half day <input type="checkbox"/> Change channel even if clients are connected	
Channel	<input type="checkbox"/> Override Group Setting Ch 11, 2462MHz	<input type="checkbox"/> Override Group Setting Ch 36, 5.18GHz	
Channel Bandwidth	<input type="checkbox"/> Override Group Setting 20 MHz	<input type="checkbox"/> Override Group Setting 20 MHz	
BSS BasicRateSet	<input type="checkbox"/> Override Group Setting all	<input type="checkbox"/> Override Group Setting all	

⊖ Advanced Settings

Radio B/G/N (2.4 GHz)		Radio A/N/AC (5.0 GHz)	
Contention Slot	<input type="checkbox"/> Override Group Setting Short		
Preamble Type	<input type="checkbox"/> Override Group Setting Short		
Guard Interval	<input type="checkbox"/> Override Group Setting Short GI	<input type="checkbox"/> Override Group Setting Short GI	
802.11n Protection	<input type="checkbox"/> Override Group Setting Enable	<input type="checkbox"/> Override Group Setting Enable	
CE Adaptive	<input type="checkbox"/> Override Group Setting Disable		
DTIM Period	<input type="checkbox"/> Override Group Setting 1 (1-255)	<input type="checkbox"/> Override Group Setting 1 (1-255)	
RTS Threshold	<input type="checkbox"/> Override Group Setting 2347 (1-2347)	<input type="checkbox"/> Override Group Setting 2347 (1-2347)	
Fragment Threshold	<input type="checkbox"/> Override Group Setting 2346 (256-2346)	<input type="checkbox"/> Override Group Setting 2346 (256-2346)	
Multicast Rate	<input type="checkbox"/> Override Group Setting Auto	<input type="checkbox"/> Override Group Setting Auto	
Tx Power	<input type="checkbox"/> Override Group Setting 100%	<input type="checkbox"/> Override Group Setting 100%	
Beacon Interval	<input type="checkbox"/> Override Group Setting 100 (40-1000 ms)	<input type="checkbox"/> Override Group Setting 100 (40-1000 ms)	
Station idle timeout	<input type="checkbox"/> Override Group Setting 60 (30-65535 seconds)	<input type="checkbox"/> Override Group Setting 60 (30-65535 seconds)	

⊖ WDS Settings

Radio B/G/N (2.4 GHz)		Radio A/N (5.0 GHz)	
WDS Functionality	None	None	
WDS #1	AP Device Name User-Defined MAC Address	AP Device Name User-Defined MAC Address	
WDS #2	AP Device Name User-Defined MAC Address	AP Device Name User-Defined MAC Address	
WDS #3	AP Device Name User-Defined MAC Address	AP Device Name User-Defined MAC Address	
WDS #4	AP Device Name User-Defined MAC Address	AP Device Name User-Defined MAC Address	
WDS VLAN Mode	Untagged Port (Enter at least one MAC address.)	Untagged Port (Enter at least one MAC address.)	
WDS VLAN ID	1	1	
WDS Encryption	None (Enter at least one MAC address.)	None (Enter at least one MAC address.)	

Radio Settings	
<b>Wireless</b>	Enable or disable the AP's 2.4GHz or 5GHz wireless radio. When disabled, no SSIDs on that frequency will be active.
<b>Band</b>	Select the wireless standard used for the AP. Combinations of 802.11b, 802.11g, 802.11n & 802.11ac can be selected.
<b>Auto Pilot</b>	Enable/disable auto channel selection. Auto channel selection will automatically set the wireless channel for the AP's 2.4GHz or 5GHz frequency based on availability and potential interference. When disabled, select a channel manually.
<b>Auto Pilot Sensitivity</b>	Select sensitivity of Auto Pilot.
<b>Auto Pilot Range</b>	Select a range from which the auto channel setting (above) will choose a channel.
<b>Auto Pilot Interval</b>	Specify a frequency for how often the auto channel setting will check/reassign the wireless channel. Check/uncheck the "Change channel even if clients are connected" box according

	to your preference.
<b>Channel</b>	When Auto Pilot is disabled, select a channel (1-11) manually.
<b>Channel Bandwidth</b>	Set the channel bandwidth or use Auto (automatically select based on interference level).
<b>BSS BasicRateSet</b>	Set a Basic Service Set (BSS) rate: this is a series of rates to control communication frames for wireless clients.

These settings are for experienced users only. Please do not change any of the values on this page unless you are already familiar with these functions.



**Changing these settings can adversely affect the performance of your AP.**

Advanced Settings	
<b>Contention Slot</b>	Select “Short” or “Long” – this value is used for contention windows in WMM.
<b>Preamble Type</b>	Set the wireless radio preamble type. The preamble type in 802.11 based wireless communication defines the length of the CRC (Cyclic Redundancy Check) block for communication between the AP and roaming wireless adapters. The default value is “Short Preamble”.
<b>Guard Interval</b>	Set the guard interval. A shorter interval can improve performance.
<b>802.11n Protection</b>	Enable/disable 802.11n protection, which increases reliability but reduces bandwidth (clients will send Request to Send (RTS) to AP, and AP will broadcast Clear to Send (CTS), before a packet is sent from client.)
<b>CE Adaptive</b>	The measurement procedure follows clause 5.3.11.2.2 of the ETSI EN 300 328 V1.8.1
<b>DTIM Period</b>	Set the DTIM (delivery traffic indication message) period value of the wireless radio. (The default value is 1)
<b>RTS Threshold</b>	Set the RTS threshold of the wireless radio. (The default value is 2347)
<b>Fragment Threshold</b>	Set the fragment threshold of the wireless radio. (The default value is 2346)

<b>Multicast Rate</b>	Set the transfer rate for multicast packets or use the “Auto” setting.
<b>Tx Power</b>	Set the power output of the wireless radio. You may not require 100% output power. Setting a lower power output can enhance security since potentially malicious/unknown users in distant areas will not be able to access your signal.
<b>Beacon Interval</b>	Set the beacon interval of the wireless radio. The default value is 100.
<b>Station idle timeout</b>	Set the interval for keepalive messages from the AP to a wireless client to verify if the station is still alive / active.

WDS Settings	
<b>WDS Functionality</b>	A wireless distribution system (WDS) is a system enabling the wireless interconnection of APs in an IEEE 802.11 network. It allows a wireless network to be expanded using multiple APs without the traditional requirement for a wired backbone to link them.
<b>AP Device Name</b>	Set AP Device Name.
<b>MAC Address</b>	Set MAC Address of AP.
<b>WDS VLAN Mode</b>	Enable / Disable VLAN function.
<b>WDS VLAN ID</b>	Set VLAN ID of WDS.
<b>WDS Encryption</b>	Set WDS Encryption.

## Edit WMM-EDCA Settings:

WMM-EDCA Settings				
<input type="checkbox"/> Override Group Setting				
WMM Parameters of Access Point				
	CWMin	CWMax	AIFSN	TxOP
Back Ground	4	10	7	0
Best Effort	4	6	3	0
Video	3	4	1	94
Voice	2	3	1	47
WMM Parameters of Station				
	CWMin	CWMax	AIFSN	TxOP
Back Ground	4	10	7	0
Best Effort	4	10	3	0
Video	3	4	2	94
Voice	2	3	2	47

When “Override Group Setting” is checked, options/fields will turn white to allow adjustments.

**Override Group Setting**

WMM-EDCA Settings:	
<b>Back Ground</b>	Access Category (AC) is Back Ground
<b>Best Effort</b>	Access Category (AC) is Best Effort
<b>Video</b>	Access Category (AC) is video
<b>Voice</b>	Access Category (AC) is voice

## Edit BandSteering Settings:

BandSteering Settings	
Bandsteering	<input type="checkbox"/> Override Group Setting <input checked="" type="radio"/> Off <input type="radio"/> 5G First <input type="radio"/> Balanced <input type="radio"/> User Define

When “Override Group Setting” is checked, options/fields will turn white to allow adjustments.

**Override Group Setting**

## Edit Profile Settings:

Profile Settings		
	Radio B/G/N (2.4 GHz)	Radio A/N/AC (5.0 GHz)
WLAN Group	<input type="checkbox"/> Override Group Setting Wizard WLAN 2.4G Group 1 ▼	<input type="checkbox"/> Override Group Setting Wizard WLAN 5G Group 2 ▼
Guest Network Group	<input type="checkbox"/> Override Group Setting Disable ▼	<input type="checkbox"/> Override Group Setting Disable ▼
RADIUS Group	<input type="checkbox"/> Override Group Setting Disable ▼	
MAC Access Control Group	<input type="checkbox"/> Override Group Setting Disable ▼	

When “Override Group Setting” is checked, options/fields will turn white to allow adjustments.

**Override Group Setting**

Profile Settings	
<b>WLAN Group</b>	Assign the AP’s 2.4GHz or 5GHz SSID(s) to a WLAN Group.
<b>Guest Network Group</b>	Assign the AP’s 2.4GHz or 5GHz SSID(s) to a Guest Network Group.
<b>RADIUS Group</b>	Assign the AP’s 2.4GHz SSID(s) to a RADIUS group. Y
<b>MAC Access Control Group</b>	Assign the AP’s 2.4GHz SSID(s) to a RADIUS group.

## Events:

Press “Refresh” to refresh the event log

Press “Save” to save the event log as .log file.

ID	Date and Time	Severity	Users	Events/Activities
15	2012/01/01 00:01:10	Low	admin	Managed AP(74:DA:38:1D:26:4E) was disconnected
14	2012/01/01 00:07:01	Low	admin	Managed AP(74:DA:38:1D:26:4E) connect successfully
13	2012/01/01 00:00:21	Low	admin	Managed AP(74:DA:38:1D:26:4E) start NMS WTP service successfully
12	2012/01/01 00:00:55	Low	admin	Managed AP(74:DA:38:1D:26:4E) start NMS WTP service successfully
11	2012/01/01 00:01:05	Low	admin	Managed AP(74:DA:38:1D:26:4E) start NMS WTP service successfully
10	2012/01/01 00:07:40	Low	admin	Managed AP(74:DA:38:1D:26:4E) was disconnected
9	2012/01/01 00:09:57	Low	admin	Managed AP(74:DA:38:1D:26:4E) connect successfully
8	2012/01/01 00:00:24	Low	admin	Managed AP(74:DA:38:1D:26:4E) start NMS WTP service successfully
7	2012/01/01 00:10:31	Low	admin	Managed AP(74:DA:38:1D:26:4E) was disconnected
6	2012/01/01 00:12:15	Low	admin	Managed AP(74:DA:38:1D:26:4E) connect successfully
5	2012/01/01 00:13:58	Low	admin	Managed AP(74:DA:38:1D:26:4E) was disconnected
4	2012/01/01 00:14:31	Low	admin	Managed AP(74:DA:38:1D:26:4E) connect successfully
3	2012/01/01 00:00:22	Low	admin	Managed AP(74:DA:38:1D:26:4E) start NMS WTP service successfully
2	2012/01/01 00:00:55	Low	admin	Managed AP(74:DA:38:1D:26:4E) start NMS WTP service successfully
1	2012/01/01 00:00:23	Low	admin	Managed AP(74:DA:38:1D:26:4E) start NMS WTP service successfully

## Add/Edit AP Group:

Configure your selected AP group. AP group settings apply to all APs in the group, unless individually set to override group settings.

You can use Profile Group Settings to assign the AP group to WLAN, Guest Network, RADIUS and Access Control groups.

## Edit Basic Group Settings:

The Group Settings panel can be used to quickly move APs between existing groups: select an AP and use the drop down menu or search to select AP groups and use << and >> arrows to move APs between groups.

Basic Group Settings	
Name	System Default
Description	System default group for APs
IGMP Snooping	Disable

Basic Group Settings	
<b>Name</b>	Edit the AP group name.
<b>Description</b>	Enter a description of the AP group for reference e.g. 2 <sup>nd</sup> Floor Office Group.
<b>IGMP Snooping</b>	Enable / Disable the IGMP Snooping function. IGMP snooping is the process of listening to Internet Group Management Protocol (IGMP) network traffic.

### Edit Web Account Group Settings:

Web Account Group Settings		
Administrator Name	<input type="text" value="admin"/>	
Administrator Password	<input type="text" value="1234"/>	(6-32Characters)

### Edit VLAN Group Settings:

VLAN Group Settings		
Wired LAN Port	VLAN Mode	VLAN ID
Wired Port(#1)	Untagged Port ▼	<input type="text" value="1"/>
Wired Port(#2)	Untagged Port ▼	<input type="text" value="1"/>
Management VLAN ID	<input type="text" value="1"/>	

# Edit Radio Group Settings:

Radio Group Settings			
	Radio B/G/N (2.4 GHz)	Radio A/N/AC (5.0 GHz)	
Wireless	Enable ▾	Enable ▾	
Band	11b/g/n ▾	11a/n/ac ▾	
Auto Pilot	Disable ▾	Disable ▾	
Auto Pilot Sensitivity	Low ▾	Low ▾	
Auto Pilot Range	Ch 1 - 11 ▾	Band 1 ▾	
Auto Pilot Interval	Half day ▾ <input type="checkbox"/> Change channel even if clients are connected	Half day ▾ <input type="checkbox"/> Change channel even if clients are connected	
Channel	Ch 11, 2462MHz ▾	Ch 36, 5.18GHz ▾	
Channel Bandwidth	20 MHz ▾	20 MHz ▾	
BSS BasicRateSet	all ▾	all ▾	
 Advanced Settings			
	Radio B/G/N (2.4 GHz)	Radio A/N/AC (5.0 GHz)	
Contention Slot	Short ▾		
Preamble Type	Short ▾		
Guard Interval	Short GI ▾	Short GI ▾	
802.11n Protection	Enable ▾	Enable ▾	
CE Adaptive	Disable ▾		
DTIM Period	1 (1-255)	1 (1-255)	
RTS Threshold	2347 (1-2347)	2347 (1-2347)	
Fragment Threshold	2346 (256-2346)	2346 (256-2346)	
Multicast Rate	Auto ▾	Auto ▾	
Tx Power	100% ▾	100% ▾	
Beacon Interval	100 (40-1000 ms)	100 (40-1000 ms)	
Station idle timeout	60 (30-65535 seconds)	60 (30-65535 seconds)	

Radio Group Settings	
<b>Wireless</b>	Enable or disable the AP group's 2.4GHz or 5GHz wireless radio. When disabled, no SSIDs on that frequency will be active.
<b>Band</b>	Select the wireless standard used for the AP group. Combinations of 802.11b, 802.11g, 802.11n & 802.11ac can be selected.
<b>Auto Pilot</b>	Enable/disable auto channel selection. Auto channel selection will automatically set the wireless channel for the AP group's 2.4GHz or 5GHz frequency based on availability and potential interference. When disabled, select a channel manually.
<b>Auto Pilot Sensitivity</b>	Select sensitivity of Auto Pilot.
<b>Auto Pilot Range</b>	Select a range from which the auto channel setting (above) will choose a channel.
<b>Auto Pilot Interval</b>	Specify a frequency for how often the auto channel setting will check/reassign the wireless channel. Check/uncheck the "Change channel even if clients are connected" box according to your preference.
<b>Channel</b>	When Auto Pilot is disabled, select a channel (1-11) manually.
<b>Channel Bandwidth</b>	Set the channel bandwidth or use Auto (automatically select based on interference level).
<b>BSS BasicRateSet</b>	Set a Basic Service Set (BSS) rate: this is a series of rates to control communication frames for wireless clients.

These settings are for experienced users only. Please do not change any of the values on this page unless you are already familiar with these functions.



**Changing these settings can adversely affect the performance of your APs.**

Advanced Settings	
<b>Contention Slot</b>	Select “Short” or “Long” – this value is used for contention windows in WMM.
<b>Preamble Type</b>	Set the wireless radio preamble type. The preamble type in 802.11 based wireless communication defines the length of the CRC (Cyclic Redundancy Check) block for communication between the AP and roaming wireless adapters. The default value is “Short Preamble”.
<b>Guard Interval</b>	Set the guard interval. A shorter interval can improve performance.
<b>802.11n Protection</b>	Enable/disable 802.11n protection, which increases reliability but reduces bandwidth (clients will send Request to Send (RTS) to AP, and AP will broadcast Clear to Send (CTS), before a packet is sent from client.)
<b>CE Adaptive</b>	The measurement procedure follows clause 5.3.11.2.2 of the ETSI EN 300 328 V1.8.1
<b>DTIM Period</b>	Set the DTIM (delivery traffic indication message) period value of the wireless radio. The default value is 1.
<b>RTS Threshold</b>	Set the RTS threshold of the wireless radio. The default value is 2347.
<b>Fragment Threshold</b>	Set the fragment threshold of the wireless radio. The default value is 2346.
<b>Multicast Rate</b>	Set the transfer rate for multicast packets or use the “Auto” setting.
<b>Tx Power</b>	Set the power output of the wireless radio. You may not require 100% output power. Setting a lower power output can enhance security since potentially malicious/unknown users in distant areas will not be able to access your signal.
<b>Beacon Interval</b>	Set the beacon interval of the wireless radio. The default value is 100.
<b>Station idle timeout</b>	Set the interval for keepalive messages from the AP to a wireless client to verify if the station is still alive/active.

## Edit WMM-EDCA Settings:

WMM-EDCA Settings				
WMM Parameters of Access Point				
	CWMin	CWMax	AIFSN	TxOP
Back Ground	4	10	7	0
Best Effort	4	6	3	0
Video	3	4	1	94
Voice	2	3	1	47

WMM Parameters of Station				
	CWMin	CWMax	AIFSN	TxOP
Back Ground	4	10	7	0
Best Effort	4	10	3	0
Video	3	4	2	94
Voice	2	3	2	47

## Edit BandSteering Settings:

BandSteering Group Settings	
Bandsteering	<input checked="" type="radio"/> Off <input type="radio"/> 5G First <input type="radio"/> Balanced <input type="radio"/> User Define

## Edit Profile Settings:

Profile Group Settings		
	Radio B/G/N (2.4 GHz)	Radio A/N/AC (5.0 GHz)
WLAN Group	Disable ▾	Disable ▾
Guest Network Group	Disable ▾	Disable ▾
RADIUS Group	Disable ▾	
MAC Access Control Group	Disable ▾	

Profile Group Settings	
<b>WLAN Group</b>	Assign the AP group's 2.4GHz or 5GHz SSIDs to a WLAN Group.
<b>Guest Network Group</b>	Assign the AP group's 2.4GHz or 5GHz SSIDs to a Guest Network Group.
<b>RADIUS Group</b>	Assign the AP group's 2.4GHz SSIDs to a RADIUS group. You can edit RADIUS groups in NMS Settings → RADIUS.
<b>MAC Access Control Group</b>	Assign the AP's 2.4GHz SSIDs to a RADIUS group. You can edit RADIUS groups in NMS Settings → Access Control.

## Edit Group Settings:

Group Settings

Members

Search

Group Name : Wizard AP Group 2

<input type="checkbox"/>	MAC Address ▲	Device Name ▼
<input type="checkbox"/>	74:DA:38:1D:26:4E	AP74DA381D264E

Search

Group Name : System Default

<input type="checkbox"/>	MAC Address ▲	Device Name ▼ ▲
<input type="checkbox"/>	74:DA:38:1D:26:5A	AP74DA381D265A

<<

>>

## ii. WLAN

Displays information about each WLAN and WLAN group in the local network and allows you to add or edit WLANs & WLAN Groups.

The search function can be used to locate a WLAN or WLAN Group. Type in the search box and the list will update:

Search   Match whole words

### WLAN

Search   Match whole words

<input type="checkbox"/>	Name/ESSID	VLAN ID	Authentication	Encryption	Additional Authentication
<input type="checkbox"/>	wap1750	1	WPA2PSK	AES	No additional authentication

### WLAN Groups

Search   Match whole words

<input type="checkbox"/>	Group Name	WLAN members	WLAN member list	Used AP	Used AP Group
<input type="checkbox"/>	Wizard WLAN 2.4G Group 1	1	wap1750	AP74DA381D264E	Wizard AP Group 2
<input type="checkbox"/>	Wizard WLAN 5G Group 2	1	wap1750	AP74DA381D264E	Wizard AP Group 2

Select a WLAN or WLAN Group using the check-boxes and click “Edit” or click “Add” to add a new WLAN or WLAN Group:



## Add/Edit WLAN:

WLAN Settings	
Name/ESSID	<input type="text"/>
Description	<input type="text"/>
VLAN ID	<input type="text" value="1"/>
Broadcast SSID	Enable ▾
Wireless Client Isolation	Disable ▾
802.11k	Disable ▾
Load Balancing	<input type="text" value="50"/> /100
Authentication Method	No Authentication ▾
Additional Authentication	No additional authentication ▾

WLAN Access Policy	
<b>Traffic Shaping Settings</b>	
Traffic Shaping	Disable ▾
Downlink	<input type="text" value="50"/> Mbps
Uplink	<input type="text" value="50"/> Mbps

WLAN Advanced Settings	
<b>Smart Handover Settings</b>	
Smart Handover	<input type="radio"/> Enable <input checked="" type="radio"/> Disable
RSSI Threshold	<input type="text" value="-80"/> dB
<b>Active WLAN Schedule Settings</b> <small>*Please enable (NMS Settings-&gt;Advanced-&gt;Date and Time-&gt;NTP Time Server) to make this function work.</small>	
Schedule Group	Disable ▾

WLAN Settings	
<b>Name/ESSID</b>	Edit the WLAN name (SSID).
<b>Description</b>	Enter a description of the SSID for reference e.g. 2 <sup>nd</sup> Floor Office HR.
<b>VLAN ID</b>	Specify the VLAN ID.
<b>Broadcast SSID</b>	Enable or disable SSID broadcast. When enabled, the SSID will be visible to clients as an available Wi-Fi network. When disabled, the SSID will not be visible as an available Wi-Fi network to clients – clients must manually enter the SSID in order to connect. A hidden (disabled) SSID is typically more secure than a visible (enabled) SSID.
<b>Wireless Client Isolation</b>	Enable or disable wireless client isolation. Wireless client isolation prevents clients connected to the AP from communicating with each other and improves security. Typically, this function is useful for corporate environments or public hot spots and can prevent brute force attacks on clients' usernames and passwords.
<b>802.11k</b>	Enable / Disable to define and expose radio and network information (helps facilitate the management and maintenance of a mobile wireless LAN).
<b>Load Balancing</b>	Load balancing limits the number of wireless clients connected to an SSID. Set a load balancing value (maximum 100).
<b>Authentication Method</b>	Select an authentication method from the drop down menu.
<b>WPA Type</b>	It can select WPA only or WPA2 only or WPA/WPA2 Mixed Mode-PSK
<b>Encryption Type</b>	It can select TKIP/AES Mixed Mode or AES
<b>Key Renewal Interval</b>	It can set renewal interval time
<b>Pre-Shared Key Type</b>	It can set Passphrase or Hex (64 characters)
<b>Pre-Shared Key</b>	It can set 8-64 characters
<b>Additional Authentication</b>	Select an additional authentication method from the drop down menu.

Various security options (wireless data encryption) are available. When data is encrypted, information transmitted wirelessly cannot be read by anyone who does not know the correct encryption key.



**It is essential to configure wireless security in order to prevent unauthorised access to your network.**



**Select hard-to-guess passwords which include combinations of numbers, letters and symbols, and change your password regularly.**

WLAN Access Policy	
<b>Traffic Shaping</b>	Enable / Disable traffic shaping.
<b>Downlink</b>	Set downlink between 1-200Mbps
<b>Uplink</b>	Set uplink between 1-200Mbps

WLAN Advanced Settings	
<b>Smart Handover</b>	Enable or disable Smart Handover.
<b>RSSI Threshold</b>	Set a RSSI Threshold level.

## Add/Edit WLAN Group:

WLAN Group Settings

<b>Name</b>	Wizard WLAN 2.4G Group 1		
<b>Description</b>	Created by Wizard		
<b>Members</b>	Search <input style="width: 100px;" type="text"/>	<input type="checkbox"/> Match whole words	
	<input type="checkbox"/>	<b>Name/ESSID</b>	<b>VLAN ID</b>
	<input checked="" type="checkbox"/>	wap1750 <input type="checkbox"/> Override	1 <input type="checkbox"/> Override <span style="border: 1px solid gray; padding: 2px;">Disable ▾</span>

\*Schedule Group function will not work until ([NMS Settings->Advanced->Date and Time->NTP Time Server](#)) are enabled.

Save
Cancel
Save & Apply

WLAN Group Settings	
<b>Name</b>	Edit the WLAN Group name.
<b>Description</b>	Enter a description of the WLAN Group for reference e.g. 2 <sup>nd</sup> Floor Office HR Group.
<b>Members</b>	Select SSIDs to include in the group using the checkboxes and assign VLAN IDs.

### iii. RADIUS

Displays information about External & Internal RADIUS Servers, Accounts and Groups and allows you to add or edit RADIUS Servers, Accounts & Groups.

The search function can be used to locate a RADIUS Server, Account or Group. Type in the search box and the list will update:

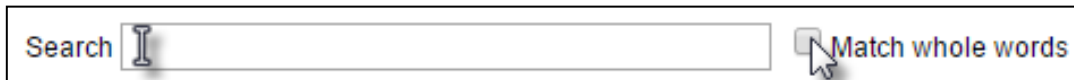

Search   Match whole words

Make a selection using the check-boxes and click “Edit” or click “Add” to add a new WLAN or WLAN Group:



#### External RADIUS Server

Search   Match whole words

<input type="checkbox"/>	Name	RADIUS Server	Authentication Port	Session Timeout (sec)	Accounting
Please add External RADIUS Server setting					

#### Internal RADIUS Server

Search   Match whole words

<input type="checkbox"/>	Name	EAP Authentication	Session Timeout (sec)	Termination-Action
Please add Internal RADIUS Server setting				

#### RADIUS Accounts (Max: 256 users)

Search   Match whole words

<input type="checkbox"/>	Name	Password	Description
Please add User Account			

#### RADIUS Group

Search   Match whole words

<input type="checkbox"/>	Name	2.4GHz	5GHz	RADIUS Accounts	Used AP	Used AP Group
Please add RADIUS group setting						

## Add/Edit External RADIUS Server:

External RADIUS Server	
Name	<input type="text"/>
Description	<input type="text"/>
RADIUS Server	<input type="text"/>
Authentication Port	<input type="text" value="1812"/>
Shared Secret	<input type="text"/>
Session Timeout	<input type="text" value="3600"/> Seconds
Accounting	<input checked="" type="radio"/> Enable <input type="radio"/> Disable
Accounting Port	<input type="text" value="1813"/>
<input type="button" value="Save"/> <input type="button" value="Cancel"/> <input type="button" value="Save &amp; Apply"/>	

<b>Name</b>	Enter a name for the RADIUS Server.
<b>Description</b>	Enter a description of the RADIUS Server for reference.
<b>RADIUS Server</b>	Enter the RADIUS server host IP address.
<b>Authentication Port</b>	Set the UDP port used in the authentication protocol of the RADIUS server.
<b>Shared Secret</b>	Enter a shared secret/password between 1 – 99 characters in length.
<b>Session Timeout</b>	Set a duration of session timeout in seconds between 0 – 86400.
<b>Accounting</b>	Enable or disable RADIUS accounting.
<b>Accounting Port</b>	When accounting is enabled (above), set the UDP port used in the accounting protocol of the RADIUS server.

## Add/Edit Internal RADIUS Server:

Upload EAP Certificate File	
EAP Certificate File Format	PKCS#12(*.pfx/*.p12)
Upload EAP Certificate File	Choose File No file chosen
Password of EAP Certificate File	<input type="text"/>
<input type="button" value="Upload"/>	
Internal RADIUS Server	
Name	<input type="text"/>
Description	<input type="text"/>
EAP Internal Authentication	PEAP(MS-PEAP) ▾
Shared Secret	<input type="text"/>
Session-Timeout	3600 Seconds
Termination-Action	<input checked="" type="radio"/> Reauthentication (RADIUS-Request) <input type="radio"/> Not-Reauthentication (Default) <input type="radio"/> Not-Send
<input type="button" value="Save"/> <input type="button" value="Cancel"/> <input type="button" value="Save &amp; Apply"/>	

Upload EAP Certificate File	
<b>EAP Certificate File Format</b>	Displays the EAP certificate file format: PKCS#12(*.pfx/*.p12)
<b>EAP Certificate File</b>	Click “Upload” to open a new window and select the location of an EAP certificate file to use. If no certificate file is uploaded, the internal RADIUS server will use a self-made certificate.

Internal RADIUS Server	
<b>Name</b>	Enter a name for the Internal RADIUS Server.
<b>Description</b>	Enter a description of the Internal RADIUS Server for reference.
<b>EAP Certificate File Format</b>	Displays the EAP certificate file format: PCK#12(*.pfx/*.p12)
<b>EAP Certificate File</b>	Click “Upload” to open a new window and select the location of an EAP certificate file to use. If no certificate file is uploaded, the internal RADIUS server will use a self-made certificate.
<b>EAP Internal Authentication</b>	Select EAP internal authentication type from the drop down menu.
<b>Shared Secret</b>	Enter a shared secret/password for use between the internal RADIUS server and RADIUS client. The shared secret should be 1 – 99 characters in length.
<b>Session Timeout</b>	Set a duration of session timeout in seconds between 0 – 86400.
<b>Termination Action</b>	Select a termination-action attribute: “Reauthentication” sends a RADIUS request to the AP, “Not-Reauthentication” sends a default termination-action attribute to the AP, “Not-Send” no termination-action attribute is sent to the AP.

### **Add/Edit/Import/Export RADIUS Accounts:**

The internal RADIUS server can authenticate up to 256 user accounts. The “RADIUS Accounts” page allows you to configure and manage users.

**RADIUS Accounts**

**User Name**  
 Example: USER1, USER2, USER3

---

**User Registration List**

User Name	Password	Description	Action
Please add Account(s)			

**RADIUS Accounts**

**User Name**  
 Example: USER1, USER2, USER3

EdimaxNew

**User Registration List**

User Name	Password	Description	Action
EdimaxNew	....		<input type="button" value="Delete"/>
Edimax1	Configured	Edimax1	

RADIUS Accounts	
<b>User Name</b>	Enter the user names here, separated by commas.
<b>Add</b>	Click “Add” to add the user to the user registration list.
<b>Reset</b>	Clear text from the user name box.

User Registration List	
<b>User Name</b>	Displays the user name.
<b>Password</b>	Enter a password.
<b>Description</b>	Enter a description of the user.
<b>Delete</b>	Delete the user.

**User Registration List**

User Name	Password	Description
Edimax1	....	Edimax1

Edit User Registration List	
<b>User Name</b>	Existing user name is displayed here and can be edited according to your preference.
<b>Password</b>	Enter or edit a password for the specified user.
<b>Description</b>	Displays current description of the user and can be edited.

<b>Delete Selected</b>	Delete selected user from the user registration list.
<b>Delete All</b>	Delete all users from the user registration list.

## Import:

If you wish to import RADIUS accounts, press “Import”. The following page is displayed below. Choose a file from a file and press “Upload” to import RADIUS accounts.

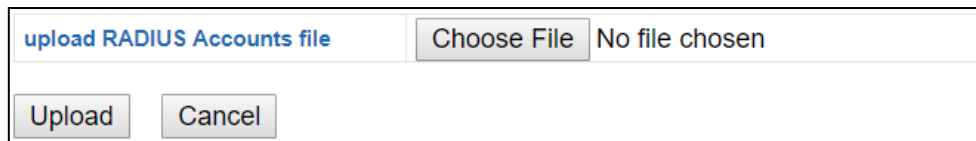

The screenshot shows a web interface for uploading RADIUS accounts. It features a text input field with the placeholder text "upload RADIUS Accounts file". To the right of the input field is a "Choose File" button, followed by the text "No file chosen". Below the input field are two buttons: "Upload" and "Cancel".

## Export:

If you wish to export your current list of RADIUS accounts, press “Export”. Your list will be saved in a format similar to the one below:

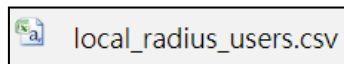

## Add/Edit RADIUS Group:

RADIUS Group Settings										
Group Name	<input type="text"/>									
Description	<input type="text"/>									
2.4GHz RADIUS	Primary : <input type="button" value="Disabled"/> Secondary : <input type="button" value="Disabled"/>									
5GHz RADIUS	Primary : <input type="button" value="Disabled"/> Secondary : <input type="button" value="Disabled"/>									
Members	Search <input type="text"/> <input type="checkbox"/> Match whole words <table border="1"> <thead> <tr> <th><input type="checkbox"/></th> <th>Username</th> <th>Password</th> </tr> </thead> <tbody> <tr> <td><input type="checkbox"/></td> <td>Edimax1</td> <td>Configured</td> </tr> <tr> <td><input type="button" value="Add"/></td> <td><input type="text"/></td> <td><input type="text" value="....."/></td> </tr> </tbody> </table>	<input type="checkbox"/>	Username	Password	<input type="checkbox"/>	Edimax1	Configured	<input type="button" value="Add"/>	<input type="text"/>	<input type="text" value="....."/>
<input type="checkbox"/>	Username	Password								
<input type="checkbox"/>	Edimax1	Configured								
<input type="button" value="Add"/>	<input type="text"/>	<input type="text" value="....."/>								
<input type="button" value="Save"/> <input type="button" value="Cancel"/> <input type="button" value="Save &amp; Apply"/>										

RADIUS Group Settings	
<b>Group Name</b>	Edit the RADIUS Group name.
<b>Description</b>	Enter a description of the RADIUS Group for reference.
<b>2.4GHz RADIUS</b>	Enable/Disable primary & secondary RADIUS servers for 2.4GHz.
<b>5GHz RADIUS</b>	Enable/Disable primary & secondary RADIUS servers for 5GHz.
<b>Members</b>	Add RADIUS user accounts to the RADIUS group.

## iv. Access Control

MAC Access Control is a security feature that can help to prevent unauthorized users from connecting to your AP.

This function allows you to define a list of network devices permitted to connect to the AP. Devices are each identified by their unique MAC address. If a device not on the list of permitted MAC addresses attempts to connect to the AP, it will be denied.

The Access Control panel displays information about MAC Access Control & MAC Access Control Groups and Groups and allows you to add or edit MAC Access Control & MAC Access Control Group settings.

The search function can be used to locate a MAC address or MAC Access Control Group. Type in the search box and the list will update:

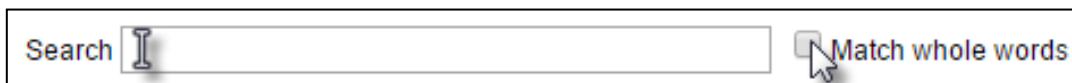

A search interface consisting of a text input field with the word "Search" inside, followed by a "Match whole words" checkbox.

Make a selection using the check-boxes and click “Edit” or click “Add” to add a new MAC Address or MAC Access Control Group:

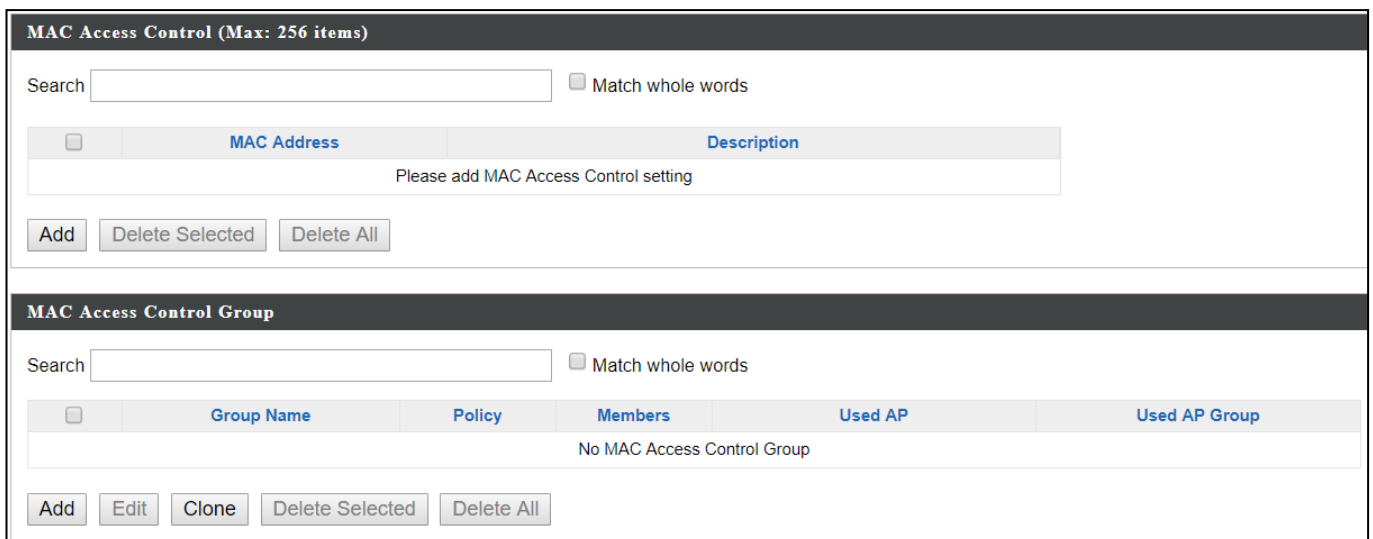

The screenshot shows two configuration panels. The top panel is titled "MAC Access Control (Max: 256 items)" and contains a search box, a "Match whole words" checkbox, a table with columns "MAC Address" and "Description", and buttons for "Add", "Delete Selected", and "Delete All". The table is currently empty with the text "Please add MAC Access Control setting". The bottom panel is titled "MAC Access Control Group" and contains a search box, a "Match whole words" checkbox, a table with columns "Group Name", "Policy", "Members", "Used AP", and "Used AP Group", and buttons for "Add", "Edit", "Clone", "Delete Selected", and "Delete All". The table is currently empty with the text "No MAC Access Control Group".

<b>Delete Selected</b>	Delete the selected entry(s) from the list.
<b>Delete All</b>	Delete all entries from the table.

### Add/Edit MAC Access Control:

Click “Add” to enter the page shown below:

**MAC Access Control**

**Add MAC Address**

Example: MAC1, MAC2, MAC3

Remain entries(256)

Add
Reset

---

**MAC Access Control List**

MAC Address	Description	Delete
Please add MAC Addresses.		

Save
Cancel
Save & Apply

<b>Add MAC Address</b>	Enter a MAC address of computer or network device manually e.g. ‘aa-bb-cc-dd-ee-ff’ or enter multiple MAC addresses separated with commas, e.g. ‘aa-bb-cc-dd-ee-ff,aa-bb-cc-dd-ee-gg’
<b>Add</b>	Click “Add” to add the MAC address to the MAC address filtering table.
<b>Reset</b>	Clear all fields.

MAC address entries will be listed in the “MAC Address Filtering Table”. Select an entry using the “Select” checkbox.

### Add/Edit/Clone MAC Access Control Group:

Click “Add” to enter the page shown below:

MAC Filter Group Settings	
<b>Group Name</b>	Edit the MAC Access Control Group name.
<b>Description</b>	Enter a description of the MAC Access Control Group for reference.
<b>Action</b>	Select “Blacklist” to deny access to specified MAC addresses in the group, and select “Whitelist” to permit access to specified MAC address in the group.
<b>Members</b>	Check the checkbox to add MAC addresses to the group.

## v. Guest Network

You can setup an additional “Guest” Wi-Fi network so guest users can enjoy Wi-Fi connectivity without accessing your primary networks. The “Guest” screen displays settings for your guest Wi-Fi network.

The Guest Network panel displays information about Guest Networks and Guest Network Groups and allows you to add or edit Guest Network and Guest Network Group settings.

The search function can be used to locate a Guest Network or Guest Network Group. Type in the search box and the list will update:

A search interface showing a text input field with the word "Search" and a cursor, followed by a checkbox labeled "Match whole words".

Make a selection using the check-boxes and click “Edit” or click “Add” to add a new Guest Network or Guest Network Group.



A screenshot of the management interface. The top section is titled "Guest Network" and includes a search box, a "Match whole words" checkbox, a table with columns "Name/SSID", "VLAN ID", "Authentication", "Encryption", and "Additional Authentication", and buttons "Add", "Edit", "Clone", "Delete Selected", and "Delete All". The bottom section is titled "Guest Network Group" and includes a search box, a "Match whole words" checkbox, a table with columns "Group Name", "Guest Network members", "Guest Network member list", "Used AP", and "Used AP Group", and buttons "Add", "Edit", "Clone", "Delete Selected", and "Delete All".

<b>Delete Selected</b>	Delete the selected entry(s) from the list.
<b>Delete All</b>	Delete all entries from the table.

## Add/Edit Guest Network:

Click “Add” to enter the page shown below:

### Guest Network Settings

Name/ESSID	<input type="text"/>
Description	<input type="text"/>
VLAN ID	<input type="text" value="1"/>
Broadcast SSID	Enable ▾
Wireless Client Isolation	STA Separator ▾
802.11k	Disable ▾
Load Balancing	<input type="text" value="50"/> /100

Authentication Method	No Authentication ▾
Additional Authentication	No additional authentication ▾

### Guest Access Policy

#### Guest Portal Settings

Guest Portal	Disable ▾
--------------	-----------

#### Traffic Shaping Settings

Traffic Shaping	Disable ▾
Downlink	<input type="text" value="50"/> Mbps
Uplink	<input type="text" value="50"/> Mbps

#### Layer 3-Filtering Settings

Rules	Disable ▾																														
Exceptions	<table><thead><tr><th>Type</th><th>IP Address</th><th>Subnet Mask</th></tr></thead><tbody><tr><td>Disable ▾</td><td>0.0.0.0</td><td>0.0.0.0</td></tr><tr><td>Disable ▾</td><td>0.0.0.0</td><td>0.0.0.0</td></tr><tr><td>Disable ▾</td><td>0.0.0.0</td><td>0.0.0.0</td></tr><tr><td>Disable ▾</td><td>0.0.0.0</td><td>0.0.0.0</td></tr><tr><td>Disable ▾</td><td>0.0.0.0</td><td>0.0.0.0</td></tr><tr><td>Disable ▾</td><td>0.0.0.0</td><td>0.0.0.0</td></tr><tr><td>Disable ▾</td><td>0.0.0.0</td><td>0.0.0.0</td></tr><tr><td>Disable ▾</td><td>0.0.0.0</td><td>0.0.0.0</td></tr><tr><td>Disable ▾</td><td>0.0.0.0</td><td>0.0.0.0</td></tr></tbody></table>	Type	IP Address	Subnet Mask	Disable ▾	0.0.0.0	0.0.0.0	Disable ▾	0.0.0.0	0.0.0.0	Disable ▾	0.0.0.0	0.0.0.0	Disable ▾	0.0.0.0	0.0.0.0	Disable ▾	0.0.0.0	0.0.0.0	Disable ▾	0.0.0.0	0.0.0.0	Disable ▾	0.0.0.0	0.0.0.0	Disable ▾	0.0.0.0	0.0.0.0	Disable ▾	0.0.0.0	0.0.0.0
	Type	IP Address	Subnet Mask																												
	Disable ▾	0.0.0.0	0.0.0.0																												
	Disable ▾	0.0.0.0	0.0.0.0																												
	Disable ▾	0.0.0.0	0.0.0.0																												
	Disable ▾	0.0.0.0	0.0.0.0																												
	Disable ▾	0.0.0.0	0.0.0.0																												
	Disable ▾	0.0.0.0	0.0.0.0																												
	Disable ▾	0.0.0.0	0.0.0.0																												
	Disable ▾	0.0.0.0	0.0.0.0																												
Disable ▾	0.0.0.0	0.0.0.0																													

### Guest Network Advanced Settings

#### Schedule Group Settings

\*This function will not work until ([NMS Settings->Advanced->Date and Time->NTP Time Server](#)) are enabled.

Schedule Group	Disable ▾
----------------	-----------

Save   Cancel   Save & Apply

Guest Network Settings	
<b>Name/ESSID</b>	Edit the Guest Network name (SSID).
<b>Description</b>	Enter a description of the Guest Network for reference e.g. 2 <sup>nd</sup> Floor Office HR.
<b>VLAN ID</b>	Specify the VLAN ID.
<b>Broadcast SSID</b>	Enable or disable SSID broadcast. When enabled, the SSID will be visible to clients as an available Wi-Fi network. When disabled, the SSID will not be visible as an available Wi-Fi network to clients – clients must manually enter the SSID in order to connect. A hidden (disabled) SSID is typically more secure than a visible (enabled) SSID.
<b>Wireless Client Isolation</b>	Enable or disable wireless client isolation. Wireless client isolation prevents clients connected to the AP from communicating with each other and improves security. Typically, this function is useful for corporate environments or public hot spots and can prevent brute force attacks on clients' usernames and passwords.
<b>802.11k</b>	Enable / Disable to define and expose radio and network information. (Helps facilitate the management and maintenance of a mobile wireless LAN)
<b>Load Balancing</b>	Load balancing limits the number of wireless clients connected to an SSID. Set a load balancing value (maximum 100).
<b>Authentication Method</b>	Select an authentication method from the drop down menu.
<b>Additional Authentication</b>	Select an additional authentication method from the drop down menu.

Various security options (wireless data encryption) are available. When data is encrypted, information transmitted wirelessly cannot be read by anyone who does not know the correct encryption key.



**It is essential to configure wireless security in order to prevent unauthorised access to your network.**



**Select hard-to-guess passwords which may include combinations of numbers, letters and symbols, and change your passwords regularly.**

Guest Access Policy	
<b>Guest Portal</b>	Enable or disable guest portal for the guest network.
<b>Traffic Shaping</b>	Enable or disable traffic shaping for the guest network.
<b>Downlink</b>	Enter a downlink limit in MB.
<b>Uplink</b>	Enter an uplink limit in MB.
<b>Rules</b>	Enter IP addresses to be filtered according to the drop down menu: "Allow all by Default", "Deny all by Default", "Internet Only" and "Disable"
<b>Exceptions</b>	After selecting the rule above, exceptions can be setup to allow / deny guest access.

Guest Network Advanced Settings	
<b>Schedule Group</b>	Select a schedule group.

<b>Clone</b>	Select an entry and clone its settings. You will be taken to the add guest network settings page shown above. Enter / edit the fields and save your selection.
--------------	--

### Add/Edit Guest Network Group:

**Guest Group Settings**

<b>Name</b>	<input type="text"/>								
<b>Description</b>	<input type="text"/>								
<b>Members</b>	<div style="display: flex; align-items: flex-start;"> <div style="margin-right: 10px;">Search <input type="text"/></div> <input type="checkbox"/> Match whole words </div> <table border="1" style="width: 100%; border-collapse: collapse; margin-top: 5px;"> <thead> <tr> <th><input type="checkbox"/></th> <th>Name/SSID</th> <th>VLAN ID</th> <th>Schedule Group</th> </tr> </thead> <tbody> <tr> <td><input type="checkbox"/></td> <td>EdimaxGuest</td> <td><input type="checkbox"/> Override <input type="text" value="1"/></td> <td><input type="checkbox"/> Override <input type="text" value="Disable"/></td> </tr> </tbody> </table> <p style="font-size: small; color: red; margin-top: 5px;">*Schedule Group function will not work until (<a href="#">NMS Settings-&gt;Advanced-&gt;Date and Time-&gt;NTP Time Server</a>) are enabled.</p>	<input type="checkbox"/>	Name/SSID	VLAN ID	Schedule Group	<input type="checkbox"/>	EdimaxGuest	<input type="checkbox"/> Override <input type="text" value="1"/>	<input type="checkbox"/> Override <input type="text" value="Disable"/>
<input type="checkbox"/>	Name/SSID	VLAN ID	Schedule Group						
<input type="checkbox"/>	EdimaxGuest	<input type="checkbox"/> Override <input type="text" value="1"/>	<input type="checkbox"/> Override <input type="text" value="Disable"/>						

Save
Cancel
Save & Apply

Guest Network Group Settings	
<b>Group Name</b>	Edit the Guest Network Group name.
<b>Description</b>	Enter a description of the Guest Network for reference.
<b>Members</b>	Add SSIDs to the Guest Network group.

## vi. Users

**Users (Max: 128 users)**

Search   Match whole words

	Name	Create Time	Valid Period	Expiration Date	Description	Traffic Usage	Traffic Limitation	Status	Action
<input type="checkbox"/>	aaa	2012/01/01 02:40:05	Always			0%	Disabled		
<input type="checkbox"/>	test1	2017/08/28 18:47:20	Always			0%	Disabled		
<input type="checkbox"/>	t2	2017/08/30 14:17:26	Always		t2	0%	Disabled		

---

**User Group**

Search   Match whole words

	Group Name	User members	User member list	Description	Role Type
<input type="checkbox"/>	Default	0			Default
<input type="checkbox"/>	test	1	aaa		Front Desk manager
<input type="checkbox"/>	111	1	test1		Guest Portal user
<input type="checkbox"/>	w1	1	t2	w1	Guest Portal user

### User Panel:

Press “Add” to add a new user, or “Edit” to edit an existing user, or “Clone” to clone an existing user’s settings. For the 3 options specified above, enter the fields below:

**User Settings**

<b>Name</b>	<input style="width: 95%;" type="text"/>
<b>Description</b>	<input style="width: 95%;" type="text"/>
<b>Password</b>	<input style="width: 95%;" type="text"/>
<b>Confirm Password</b>	<input style="width: 95%;" type="text"/>
<b>User Group</b>	Default ▼

**Usage Traffic Management**

<b>Maximum Usage Traffic</b>	<input type="checkbox"/> <b>Enable</b>	<input style="width: 50px;" type="text" value="100"/>	<input style="width: 50px;" type="text" value="MB"/> (Max: 1 TB)
------------------------------	--	---	--

## User Group Panel:

Click “Add” to add a new user group, or “Edit” to edit an existing user group, or “Clone” to clone an existing user group’s settings. For the 3 options specified above, enter the fields below:

**User Group Settings**

<b>Name</b>	<input type="text"/>								
<b>Description</b>	<input type="text"/>								
<b>Role Type</b>	Default ▾								
	Search <input type="text"/> <input type="checkbox"/> Match whole words								
<b>Members</b>	<table border="1"><thead><tr><th><input type="checkbox"/></th><th>Name</th><th>User Group</th><th>Description</th></tr></thead><tbody><tr><td colspan="4">Please add User setting</td></tr></tbody></table>	<input type="checkbox"/>	Name	User Group	Description	Please add User setting			
<input type="checkbox"/>	Name	User Group	Description						
Please add User setting									

Apply Cancel

## vii. Guest Portal

A guest portal is a web page which is displayed to newly connected users before they are granted broader access to network resources.

**Guest Portal**

Search   Match whole words

<input type="checkbox"/>	Name	Guest Portal Type	Used Guest Network
Please add Guest Portal setting			

Add Edit Delete Selected Delete All

**Guest Portal Settings**

Idle Timeout	5 ▾ minutes
Login Password Retry	5 (1-30 times)
Lockout	5 (1-30 times)

Save Save & Apply

Guest Portal Settings	
<b>Idle Timeout</b>	Select an idle timeout time from the drop down menu.
<b>Login Password Retry Lockout</b>	Enter a number (between 1 and 30) for the number of login password retry. If login password has been entered incorrectly for the number entered here, it will be locked.

**Add / Edit:**

Enter the fields according to the selected “Guest Portal Type” below:

Dynamic Users ▼
Free
Service Level Agreement
Static Users
<b>Dynamic Users</b>
External Captive Portal

## Free Guest Portal Type:

Guest Portal Settings	
Name	portal1
Description	portl1
Guest Portal Type	Free ▼
Landing Page	<input checked="" type="radio"/> Promotion URL <input type="text" value="http://"/> ▼
<input type="text"/>	
<input type="button" value="Save &amp; Apply"/> <input type="button" value="Cancel"/>	

Guest Portal Settings	
<b>Name</b>	Enter / edit portal name.
<b>Description</b>	Enter / edit description of the portal for reference.
<b>Landing Page</b>	Enter a "Promotion URL".

## User Level Agreement Guest Portal Type:

Guest Portal Settings	
Name	portal1
Description	portl1
Guest Portal Type	Service Level Agreement ▼
Landing Page	<input checked="" type="radio"/> Redirect to the original URL <input type="radio"/> Promotion URL <input type="text" value="http://"/>
Default Language	Global (English) ▼

Guest Portal Customization	
<a href="#">Login Portal</a>	<a href="#">Edit</a>
<p>Login page preview</p>	 <div data-bbox="638 952 1045 1265" style="border: 1px solid gray; padding: 5px;"> <p style="text-align: center;">Terms and Conditions of Use</p> <p>Please read these terms and conditions of use ("Terms and Conditions") carefully before accessing and browsing this web site ("Web Site"). You can use this web site only if you agree to and accept the Terms and Conditions without limitation or reservation. We may at our sole and exclusive discretion, change, alter, modify, add, and/or remove portions of the Terms and Conditions at any time by updating the contents of this page. You are requested to visit this page and check the then effective Terms and Conditions periodically.</p> <p style="text-align: center;">Limitation of Use</p> <p>All materials on this Web Site are protected by copyright laws, and other applicable laws of each country throughout the world and treaty provisions. Except for personal or non-commercial internal use, you are prohibited to use (including, without limitation,</p> </div> <div data-bbox="758 1276 933 1321" style="text-align: center; margin-top: 10px;"> <input type="button" value="Continue"/> </div>

Guest Portal Settings	
<b>Name</b>	Enter / edit portal name.
<b>Description</b>	Enter / edit description of the portal for reference.
<b>Landing Page</b>	Select between "Redirect to the original URL" or "Promotion URL" (enter the promotion URL).
<b>Default Language</b>	Choose a default language.

For Login Portal, click "Edit" and see below to edit the login portal.

## Static Users Guest Portal Type:

Guest Portal Settings	
Name	portal1
Description	portl1
Guest Portal Type	Static Users ▼
Authentication Server	Local Database ▼
Authentication User Group	111 ▼
Landing Page	<input checked="" type="radio"/> Redirect to the original URL <input type="radio"/> Promotion URL <input type="text" value="http://"/>
Default Language	Global (English) ▼

Guest Portal Customization	
Login Portal	<input type="button" value="Edit"/>
Login page preview	  <p>The preview shows a login form with the EDIMAX logo and tagline 'NETWORKING PEOPLE TOGETHER'. The form title is 'Captive Portal Login'. It includes a language dropdown set to 'Global (English)', 'User Name' and 'Password' input fields, a red 'Login' button, a checked 'Remember Me' checkbox, and an unchecked checkbox for 'Accept Terms of use' with a link to the terms.</p>

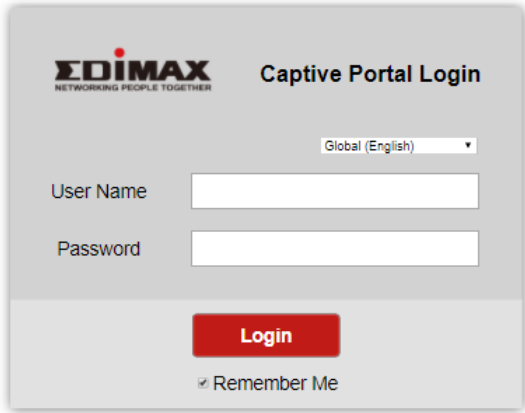
Guest Portal Settings	
<b>Name</b>	Enter / edit portal name.
<b>Description</b>	Enter / edit description of the portal for reference.
<b>Authentication Server</b>	Select an authentication server.
<b>Authentication User Group</b>	Select an authentication user group.
<b>Landing Page</b>	Select between “Redirect to the original URL” or “Promotion URL” (enter the promotion URL).
<b>Default Language</b>	Choose a default language.

For Login Portal, click “Edit” and see below to edit the login portal.

### Dynamic Users Guest Portal Type:

**Guest Portal Settings**

<b>Name</b>	<input type="text" value="portal1"/>
<b>Description</b>	<input type="text" value="port1"/>
<b>Guest Portal Type</b>	Dynamic Users ▾
<b>Authentication Server</b>	Local Database ▾
<b>Authentication User Group</b>	111 ▾
<b>Landing Page</b>	<input checked="" type="radio"/> Redirect to the original URL <input type="radio"/> Promotion URL   <input type="text" value="http://"/> ▾
<b>Default Language</b>	Global (English) ▾

**Front Desk Settings**

<b>User Group</b>	test ▾
<b>Generation URL</b>	http://192.168.2.3/frontdesk.html
<b>Guest Account Creation</b>	<input checked="" type="checkbox"/> Replace expired user, when user table is full
<b>Printout Message</b>	<input type="button" value="Edit"/>
<b>Notification Method</b>	<input checked="" type="checkbox"/> Printout

**Guest Portal Customization**

<b>Login Portal</b>	<input type="button" value="Edit"/>
<b>Login page preview</b>	 <p>The preview shows a login page with the EDIMAX logo, a language dropdown set to 'Global (English)', fields for 'User Name' and 'Password', a red 'Login' button, a 'Remember Me' checkbox, and a link to 'Accept Terms of use'.</p>

Guest Portal Settings	
<b>Name</b>	Enter / edit portal name.
<b>Description</b>	Enter / edit description of the portal for reference.
<b>Authentication Server</b>	Select an authentication server.
<b>Authentication User Group</b>	Select an authentication user group.
<b>Landing Page</b>	Select between “Redirect to the original URL” or “Promotion URL” (enter the promotion URL).
<b>Default Language</b>	Choose a default language.

Front Desk Settings	
<b>User Group</b>	Select a user group.
<b>Generation URL</b>	Go to this URL to create dynamic account (and password) for a user.
<b>Guest Account Creation</b>	Check / uncheck to enable / disable “Replace expired user when user table is full”.
<b>Printout Message</b>	Click “Edit” to edit printout message, please see below.
<b>Notification Method</b>	Check / uncheck to enable / disable notification by printout.

Definition Table	
Symbol	Description
{SSID}	The SSID for Guest Portal user
{USERNAME}	The Name of Guest Portal user
{PASSWORD}	The Password of Guest Portal user
{EXPIRETIME}	The expire time of user account
{CREATETIME}	The create time of user account
{SN}	The Serial number of user account

\* While printing the user data in Front Desk page, the "Symbol" will be replaced by the value in Users database.

---

Printout Content
<p>Welcome!</p> <p>EDIMAX Technology Co., Ltd</p> <p>-----</p> <p>Guest Internet Service</p> <p>-----</p> <p>SSID: {SSID}</p> <p>Username: {USERNAME}</p> <p>Password: {PASSWORD}</p> <p>Expire Time: {EXPIRETIME}</p> <p>-----</p> <p>Create Time: <u>{CREATETIME}</u></p> <p>S/N: {SN}</p> <p>-----</p> <p>Thank you very much !</p>

Preview   Confirm   Cancel

Click “Preview” to preview the printout, “Confirm” to confirm the message, or “Cancel” to cancel the changes.

For Login Portal, click “Edit” and see below to edit the login portal.

## External Captive Portal Guest Portal Type:

Guest Portal Settings	
Name	<input type="text"/>
Description	<input type="text"/>
Guest Portal Type	External Captive Portal ▾
Landing Page	<input checked="" type="radio"/> Use external redirect URL <input type="radio"/> Promotion URL <input type="text" value="http://"/> ▾ <input type="text"/>



External Settings	
External Type	Authentication Text ▾
Login URL	<input type="text" value="http://"/> <input type="text" value="172.217.27.132"/> <input type="button" value="Resolve"/>
Authentication Text	<input type="text"/> (16-32Characters) <small>To know how to use Authentication Text. Please, <a href="#">Click me</a>.</small>

Guest Portal Settings	
<b>Name</b>	Enter / edit portal name.
<b>Description</b>	Enter / edit description of the portal for reference.
<b>Landing Page</b>	Select between “Use external redirect URL” or “Promotion URL” (enter the promotion URL).

External Settings	
<b>Login URL</b>	Enter / edit a login URL.
<b>Authentication Text</b>	Enter an authentication text. Click “Click me” for help.

## Editing “Login Portal”:

Login Portal Customization

Header Image	<div style="border: 1px solid #ccc; padding: 2px; display: flex; align-items: center;"> <input type="button" value="Choose File"/> No file chosen         </div> <div style="text-align: center; margin: 5px 0;">  </div> <p style="font-size: small; color: red;">Size: 800x200 pixels</p>
Logo Image	<div style="border: 1px solid #ccc; padding: 2px; display: flex; align-items: center;"> <input type="button" value="Choose File"/> No file chosen         </div> <div style="text-align: center; margin: 5px 0;">  </div> <p style="font-size: small; color: red;">Size: 200x50 pixels</p>
Title Message	<input type="text" value="Captive Portal Login"/>
Background Color	<input type="text" value="FFFFFF"/>
Terms of use	<input type="checkbox"/> Accept by Default <div style="border: 1px solid #ccc; padding: 5px; font-size: small;"> <p style="text-align: center; margin: 0;">Terms and Conditions of Use</p> <p>Please read these terms and conditions of use ("Terms and Conditions") carefully before accessing and browsing this web site ("Web Site"). You can use this web site only if you agree to and accept the Terms and Conditions without limitation or reservation. We may at our sole and exclusive discretion, change, alter, modify, add, and/or remove portions of the Terms and Conditions at any time by updating the contents of this page. You are requested to visit this page and check the then effective Terms and Conditions periodically.</p> </div>

<b>Header Image</b>	Click “Choose File” to select a file as the header image.
<b>Logo Image</b>	Click “Choose File” to select a file as the logo image. (Only for Static and Dynamic users guest portal type)
<b>Title Message</b>	Enter / edit a title message. (Only for Static and Dynamic users guest portal type)
<b>Background Color</b>	Click on the field where color selection will be available. Select a desired color.
<b>Terms of use</b>	Enter / edit the terms of use message

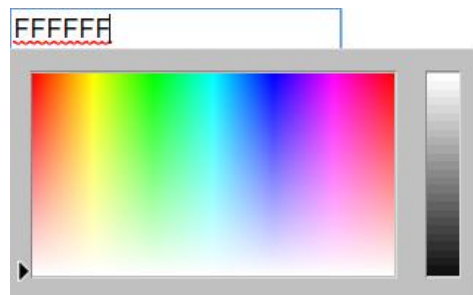

Click “Preview” to preview the printout, “Confirm” to confirm the message, or “Cancel” to cancel the changes.

### viii. Zone Edit

Zone Edit displays information about zones for use with the Zone Plan feature and allows you to add or edit zones.

The search function can be used to find existing zones. Type in the search box and the list will update:

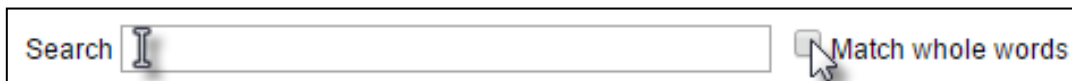

A search bar with the text "Search" and a cursor icon. To the right of the search bar is a checkbox labeled "Match whole words".

Make a selection using the check-boxes and click “Edit” or click “Add” to add a new zone.



Two buttons: "Edit" and "Add". The "Edit" button has a checkmark icon to its left and a hand cursor pointing to it. The "Add" button is below the "Edit" button.

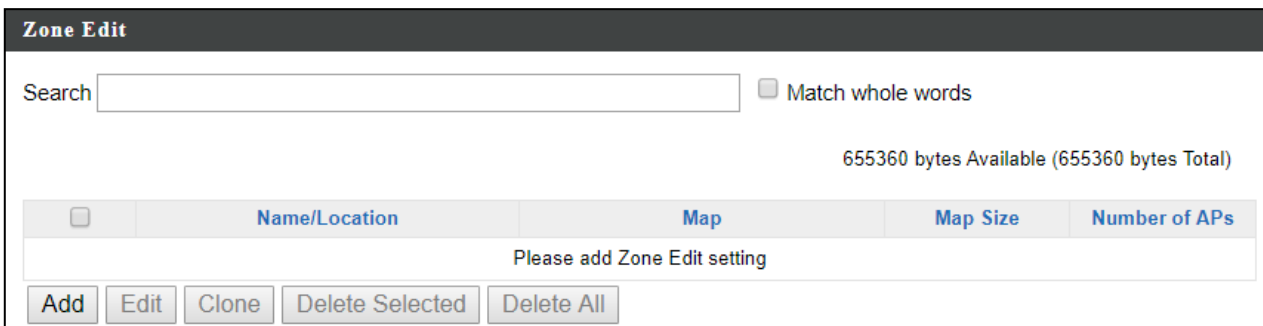

**Zone Edit**

Search   Match whole words

655360 bytes Available (655360 bytes Total)

<input type="checkbox"/>	Name/Location	Map	Map Size	Number of APs
Please add Zone Edit setting				

## Add/Edit Zone:

**Upload Zone Image**

Map Image File
Choose File
No file chosen

Upload



**Member(s) Settings**

Name/Location

Description

Search

 Match whole words

	MAC Address	Device Name	Model	Status
<input type="checkbox"/>	System Default			
<input type="checkbox"/>	74:DA:38:1D:26:5A	AP74DA381D265A	WAP1200	<span style="color: green;">●</span>
<input type="checkbox"/>	Wizard AP Group 2			
<input type="checkbox"/>	74:DA:38:1D:26:4E	AP74DA381D264E	WAP1200	<span style="color: green;">●</span>

Apply
Cancel

### Upload Zone Image

<b>Choose File</b>	Click to locate an image file to be displayed as a map in the Zone Plan feature. Typically a floor plan image is useful.
--------------------	--

### Member(s) Setting

<b>Name/Location</b>	Name the location or simply enter the name of the location.
<b>Description</b>	Enter a description of the zone/location for reference.
<b>Members</b>	Assign APs to the specified zone/location for use with the Zone Plan feature.

## ix. Schedule

Setup schedule start time/end time in Active WLAN Schedule Settings or Guest Network Advanced Settings.

### Schedule

Search   Match whole words

<input type="checkbox"/>	Name	Description	Day of week	Time
Please add Schedule setting				

### Schedule Groups

Search   Match whole words

<input type="checkbox"/>	Group Name	Schedule members	Schedule member list
Please add Schedule group setting			

### Add / Edit:

### Schedule Settings

Name

Description

Sun.	Mon.	Tue.	Wed.	Thu.	Fri.	Sat.
<input type="checkbox"/>	<input type="checkbox"/>	<input type="checkbox"/>	<input type="checkbox"/>	<input type="checkbox"/>	<input type="checkbox"/>	<input type="checkbox"/>

Start Time  :  End Time  :

## x. Smart Roaming

Smart roaming permits continuous connectivity on wireless devices that are moving. The handoffs from one station to another are fast and secure, and are managed seamlessly.

Roaming Groups				
<input type="checkbox"/>	Group Name	Used WLAN/GUEST SSID	Used WLAN/GUEST Group	Used AP Number
Please add Roaming Group setting				
<input type="button" value="Add"/> <input type="button" value="Edit"/> <input type="button" value="Delete Selected"/> <input type="button" value="Delete All"/>				

### Add / Edit:

Roaming Group Settings	
Name	<input type="text"/>
Description	<input type="text"/>
Mobility Domain	<input type="text"/>
Encryption Key	<input type="text"/>
Over the DS	<input type="radio"/> Enable <input checked="" type="radio"/> Disable
SSID Type	<input checked="" type="radio"/> WLAN <input type="radio"/> GUEST
GUEST SSID	GUEST Group: <input type="text" value="1234"/> GUEST: <input type="text" value="None"/>
WLAN SSID	WLAN Group: <input type="text" value="group1"/> WLAN: <input type="text" value="None"/>
<input type="button" value="Save"/> <input type="button" value="Cancel"/> <input type="button" value="Save &amp; Apply"/>	

Roaming Group Settings	
<b>Name</b>	Enter / edit the name of roaming group.
<b>Description</b>	Enter / edit a description for reference.
<b>Mobility Domain</b>	Enter / edit a mobility domain.
<b>Encryption Key</b>	Enter / edit an encryption key.
<b>Over the DS</b>	Check to enable / disable this function.
<b>SSID Type</b>	Select the SSID type.
<b>Guest SSID</b>	Select the Guest Group from the drop down menu. Select a Guest from the drop down menu.
<b>WLAN SSID</b>	Select the WLAN Group from the drop down menu. Select a WLAN from the drop down menu.

## xi. Device Monitoring

This page monitors the device's status (alive or not alive) after you set the Device IP.

The screenshot shows the 'Device Monitoring' interface. At the top, there is a search bar with a 'Match whole words' checkbox. Below the search bar is a table with three columns: 'Device IP', 'Description', and 'Status'. The table is currently empty, with the text 'Please add devices' centered in the first row. At the bottom of the interface, there are five buttons: 'Add', 'Edit', 'Delete Selected', 'Delete All', and 'Email Setting'.

### Add / Edit:

The screenshot shows the 'Add IP Address' form and the 'Devices List' table. The 'Add IP Address' form has a large text input field and two buttons: 'Add' and 'Reset'. Below the form is the 'Devices List' table, which has three columns: 'Device IP', 'Description', and 'Delete'. The table contains one row with the IP address '192.168.2.100' and the description 'cap300'. At the bottom of the interface, there are two buttons: 'Apply' and 'Cancel'.

Enter an IP Address and click “Add” to add the device(s). Click “Reset” to clear the field.

## xii. Firmware Upgrade

Firmware Upgrade allows you to upgrade firmware to AP Groups. First, upload the firmware file from a local disk or external FTP server: locate the file and click “Upload” or “Check”. The table below will display the Firmware Name, Firmware Version, NMS Version, Model and Size.

Then click “Upgrade All” to upgrade all APs in the Array or select AP groups from the list using check-boxes and click “Upgrade Selected” to upgrade only selected APs.

### Firmware Upgrade

Update firmware from  Local  External FTP Server

Firmware File  No file chosen

Timeout  Seconds

Firmware Name	Firmware Version	NMS Version	Model	Size (bytes)

### Access Point Group

<input type="checkbox"/>	Group Name	Index	MAC Address	Device Name	Model	IP Address	Status	Firmware Version	NMS Version	Progress
<input type="checkbox"/>	System Default (1)									
<input type="checkbox"/>		1	74:DA:38:1D:26:5A	AP74DA381D265A	WAP1200	192.168.2.102		1.8.1	1.3.2.0	<input type="text" value="0%"/>
<input type="checkbox"/>	Wizard AP Group 2 (1)									
<input type="checkbox"/>		1	74:DA:38:1D:26:4E	AP74DA381D264E	WAP1200	192.168.2.101		1.8.1	1.3.2.0	<input type="text" value="0%"/>

### xiii. Advanced

#### System Security:

Configure the NMS system login name and password.

System Security	
NMS Security Name	<input type="text" value="administrator"/>
NMS Security Key	<input type="text" value="1234567890123456"/> (8~16 Characters)
Sync NMS Security with Active Managed APs	<input type="checkbox"/> Enable <i>*Before changing NMS Security Name and Key, please make sure all Managed APs are connected; all other configuration update is complete, and status color is green.</i>
<input type="button" value="Apply"/>	

#### Date & Time:

Configure the date & time settings of the AP Array. The date and time of the APs can be configured manually or can be synchronized with a time server.

Date and Time Settings						
Local Time	2012	Year	Jan	Month	1	Day
	0	Hours	00	Minutes	00	Seconds
<input type="button" value="Acquire Current Time from Your PC"/>						
NTP Time Server						
Use NTP	<input type="checkbox"/> Enable					
Auto Daylight Saving	<input checked="" type="checkbox"/> Enable					
Server Name	User-Defined <input type="text"/>					
Update Interval	24 (Hours)					
Time Zone						
Time Zone	(GMT+08:00) Taipei, Taiwan					
<input type="button" value="Save"/> <input type="button" value="Cancel"/> <input type="button" value="Save &amp; Apply"/>						

Date and Time Settings	
<b>Local Time</b>	Set the AP's date and time manually using the drop down menus.
<b>Acquire Current Time from your PC</b>	Click "Acquire Current Time from Your PC" to enter the required values automatically according to your computer's current time and date.

NTP Time Server	
<b>Use NTP</b>	The AP also supports NTP (Network Time Protocol) for automatic time and date setup.
<b>Server Name</b>	Enter the host name or IP address of the time server if you wish.
<b>Update Interval</b>	Specify a frequency (in hours) for the AP to update/synchronize with the NTP server.

Time Zone	
<b>Time Zone</b>	Select the time zone of your country/ region. If your country/region is not listed, please select another country/region whose time zone is the same as yours.

## Google Maps:

Click on the link below the entry field and follow Google's instructions to obtain an API key. Enter the key into the entry field.

The screenshot shows a dialog box titled "Google Maps". It contains a text input field labeled "API Key" on the left. To the right of the input field is a link: "(Please go to [https://console.developers.google.com/flows/enableapi?apiid=maps\\_backend&keyType=CLIENT\\_SIDE&reusekey=true](https://console.developers.google.com/flows/enableapi?apiid=maps_backend&keyType=CLIENT_SIDE&reusekey=true) to apply for an API key.)". At the bottom of the dialog box, there are two buttons: "Apply" and "Cancel".

## VI-8. Local Network

Dashboard

Zone Plan

NMS Monitor

NMS Settings

Local Network

Local Settings

Toolbox

### i. Network Settings

#### LAN-Side IP Address:

The “LAN-side IP address” page allows you to configure your AP Controller on your Local Area Network (LAN). You can enable the AP to dynamically receive an IP address from your router’s DHCP server or you can specify a static IP address for your AP, as well as configure DNS servers. You can also set your AP Controller as a DHCP server to assign IP addresses to other devices on your LAN.



**The AP’s default IP address is 192.168.2.2**



**Disable other DHCP servers on the LAN if using AP Controllers DHCP Server.**

LAN-side IP Address	
IP Address Assignment	Static IP Address ▾
IP Address	192.168.2.2
Subnet Mask	255.255.255.0
Default Gateway	
Primary DNS Address	0.0.0.0
Secondary DNS Address	0.0.0.0

LAN-side IP Address	
<b>IP Address Assignment</b>	Select “Static IP” to manually specify a static/fixed IP address for your AP. Select “DHCP Client” for your AP to be assigned a dynamic IP address from your router’s DHCP server, or select “DHCP Server” for your AP to act as a DHCP server and assign IP addresses on your LAN.

Static IP Address	
<b>IP Address</b>	Specify the IP address here. This IP address will be assigned to your AP and will replace the default IP address.
<b>Subnet Mask</b>	Specify a subnet mask. The default value is 255.255.255.0
<b>Default Gateway</b>	For DHCP users, select “From DHCP” to get default gateway from your DHCP server or “User-Defined” to enter a gateway manually. For static IP users, the default value is blank.
<b>Primary DNS Address</b>	For static IP users, the default value is blank.
<b>Secondary DNS Address</b>	For static IP users, the default value is blank.

**LAN-side IP Address**

IP Address Assignment	DHCP Client ▼	
IP Address	192.168.2.2	
Subnet Mask	255.255.255.0	
Default Gateway	From DHCP ▼	
Primary DNS Address	From DHCP ▼	0.0.0.0
Secondary DNS Address	From DHCP ▼	0.0.0.0

DHCP Client	
<b>IP Address</b>	When “DHCP Client” is selected this value cannot be modified.
<b>Subnet Mask</b>	When “DHCP Client” is selected this value cannot be modified.
<b>Default Gateway</b>	Select “From DHCP” or select “User-Defined” and enter a default gateway.
<b>Primary DNS Address</b>	Select “From DHCP” or select “User-Defined” and enter a primary DNS address.
<b>Secondary DNS Address</b>	Select “From DHCP” or select “User-Defined” and enter a secondary DNS address.

LAN-side IP Address	
IP Address Assignment	DHCP Server ▼
IP Address	192.168.2.2
Subnet Mask	255.255.255.0
IP Address Range	192.168.2.120 ~ 192.168.2.140
Domain Name	setup.edimax.com
Lease Time	One Hour ▼
Default Gateway	
Primary DNS Address	0.0.0.0
Secondary DNS Address	0.0.0.0

DHCP Server Static IP Address			
Index	MAC Address	IP Address	Action
1			Add

DHCP Client List			
Index	MAC Address	IP Address	Lease Time
No DHCP Client			

Apply

DHCP Server	
<b>IP Address</b>	Specify the IP address here. This IP address will be assigned to your AP and will replace the default IP address.
<b>Subnet Mask</b>	Specify a subnet mask. The default value is 255.255.255.0
<b>IP Address Range</b>	Enter the start and end IP address of the IP address range which your AP's DHCP server will assign to devices on the network.
<b>Domain Name</b>	Enter a domain name.
<b>Lease Time</b>	Select a lease time from the drop down menu. IP addresses will be assigned for this period of time.
<b>Default Gateway</b>	Enter a default gateway.
<b>Primary DNS Address</b>	Enter a primary DNS address.
<b>Secondary DNS Address</b>	Enter a secondary DNS address.

Your AP's DHCP server can be configured to assign static (fixed) IP addresses to specified network devices, identified by their unique MAC address:

DHCP Server Static IP Address	
<b>MAC Address</b>	Enter the MAC address of the network device to be assigned a static IP address.
<b>IP Address</b>	Specify the IP address to assign the device.
<b>Add</b>	Click to assign the IP address to the device.

## LAN Port Settings:

The “LAN Port” page allows you to configure the settings for your AP Controllers wired LAN (Ethernet) ports.

Wired LAN Port	Enable	Speed & Duplex	Flow Control	802.3az
LAN1	Enabled ▾	Auto ▾	Enabled ▾	Enabled ▾

Apply

<b>Wired LAN Port</b>	Identifies LAN port 1.
<b>Enable</b>	Enable/disable specified LAN port.
<b>Speed &amp; Duplex</b>	Select a speed & duplex type for specified LAN port, or use the “Auto” value. LAN ports can operate up to 1000Mbps and full-duplex enables simultaneous data packets transfer/receive.
<b>Flow Control</b>	Enable/disable flow control. Flow control can pause new session request until current data processing is complete, in order to avoid device overloads under heavy traffic.
<b>802.3az</b>	Enable/disable 802.3az. 802.3az is an Energy Efficient Ethernet feature which disables unused interfaces to reduce power usage.

**VLAN:**

“VLAN” (Virtual Local Area Network) enables you to configure VLAN settings. A VLAN is a local area network which maps workstations virtually instead of physically and allows you to group together or isolate users from each other.

 **VLAN IDs in the range 1 – 4095 are supported.**

**VLAN Interface**

Wired LAN Port	VLAN Mode	VLAN ID
LAN1	Untagged Port ▼	1

Wireless 2.4GHz	VLAN Mode	VLAN ID
SSID [WIFI1700 F1006A_C_1]	Untagged Port	1
SSID [WIFI1700 F1006A_C_2]	Untagged Port	1

Wireless 5GHz	VLAN Mode	VLAN ID
SSID [WIFI1700 F1006A_C_1]	Untagged Port	1

**Management VLAN**

<b>VLAN ID</b>	1
----------------	---

VLAN Interface	
<b>Wired LAN Port/Wireless</b>	Identifies LAN port 1 and wireless SSIDs.
<b>VLAN Mode</b>	Select “Tagged Port” or “Untagged Port” for specified LAN interface.
<b>VLAN ID</b>	Set a VLAN ID for specified interface, if “Untagged Port” is selected.

Management VLAN	
<b>VLAN ID</b>	Specify the VLAN ID of the management VLAN. Only the hosts belonging to the same VLAN can manage the device.

## ii. 2.4GHz 11bgn

The “2.4GHz 11bgn” menu allows you to view and configure information for your AP’s 2.4GHz wireless network across five categories: Basic, Advanced, Security, WDS & Guest Network.

### Basic:

The “Basic” screen displays basic settings for your AP’s 2.4GHz Wi-Fi network.

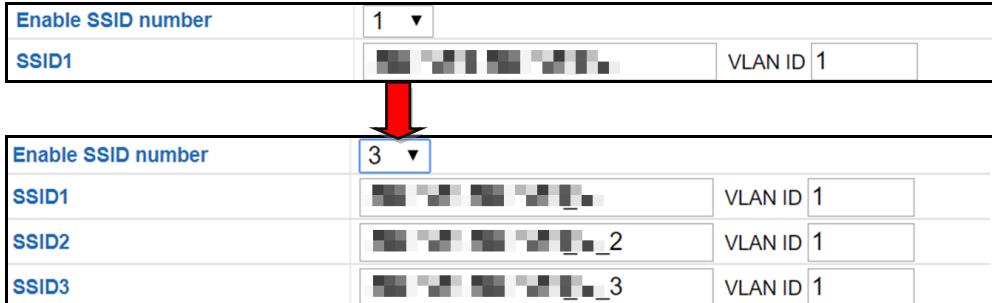
<b>Wireless</b>	Enable or disable the AP’s 2.4GHz wireless radio. When disabled, no 2.4GHz SSIDs will be active.
<b>Band</b>	Wireless standard used for the AP. Combinations of 802.11b, 802.11g & 802.11n can be selected.
<b>Enable SSID Number</b>	Select how many SSIDs to enable for the 2.4GHz frequency from the drop down menu. A maximum of 16 can be enabled. 
<b>SSID#</b>	Enter the SSID name for the specified SSID (up to 16). The SSID can consist of any combination of up to 32 alphanumeric characters.

<b>VLAN ID</b>	Specify a VLAN ID for each SSID.
<b>Auto Channel</b>	Enable/disable auto channel selection. Enable: Auto channel selection will automatically set the wireless channel for the AP's 2.4GHz frequency based on availability and potential interference. Disable: Select a channel manually as shown in the next table.
<b>Auto Channel Range</b>	Select a range to which auto channel selection can choose from.
<b>Auto Channel Interval</b>	Select a time interval for how often the auto channel setting will check/reassign the wireless channel. Check/uncheck the "Change channel even if clients are connected" box according to your preference.
<b>Channel Bandwidth</b>	Select the channel bandwidth: 20MHz (lower performance but less interference); or 40MHz (higher performance but potentially higher interference); or Auto (automatically select based on interference level).
<b>BSS BasicRateSet</b>	Set a Basic Service Set (BSS) rate: this is a series of rates to control communication frames for wireless clients.

When auto channel is disabled, configurable fields will change. Select a wireless channel manually:

<b>Auto Channel</b>	<input checked="" type="radio"/> Enable <input type="radio"/> Disable
<b>Auto Channel Range</b>	Ch 1 - 11 ▼
<b>Auto Channel Interval</b>	One day ▼ <input type="checkbox"/> Change channel even if clients are connected
<b>Channel Bandwidth</b>	Auto ▼
<b>BSS BasicRateSet</b>	all ▼



<b>Auto Channel</b>	<input type="radio"/> Enable <input checked="" type="radio"/> Disable
<b>Channel</b>	Ch 11, 2462MHz ▼
<b>Channel Bandwidth</b>	Auto, +Ch 7 ▼
<b>BSS BasicRateSet</b>	all ▼

<b>Channel</b>	Select a wireless channel from 1 – 11.
<b>Channel Bandwidth</b>	Set the channel bandwidth: 20MHz (lower performance but less interference); or 40MHz (higher performance but potentially higher interference); or Auto (automatically select based on interference level).
<b>BSS BasicRateSet</b>	Set a Basic Service Set (BSS) rate: this is a series of rates to control communication frames for wireless clients.

## Advanced:

These settings are for experienced users only. Please do not change any of the values on this page unless you are already familiar with these functions.



**Changing these settings can adversely affect the performance of your AP.**

2.4GHz Advanced Settings	
Contention Slot	Short ▾
Preamble Type	Short ▾
Guard Interval	Short GI ▾
802.11g Protection	<input checked="" type="radio"/> Enable <input type="radio"/> Disable
802.11n Protection	<input checked="" type="radio"/> Enable <input type="radio"/> Disable
DTIM Period	1 (1-255)
RTS Threshold	2347 (1-2347)
Fragment Threshold	2346 (256-2346)
Multicast Rate	Auto ▾
Tx Power	100% 21dbm ▾
Beacon Interval	100 (40-1000 ms)
Station Idle Timeout	60 (30-65535 seconds)
Airtime Fairness	Disabled ▾ <a href="#">Edit SSID Rate</a>

[Apply](#) [Cancel](#)

<b>Contention Slot</b>	Select “Short” or “Long” – this value is used for contention windows in WMM.
<b>Preamble Type</b>	Set the wireless radio preamble type. The preamble type in 802.11 based wireless communications defines the length of the CRC (Cyclic Redundancy Check) block for communication between the AP and roaming wireless adapters. The default value is “Short Preamble”.
<b>Guard Interval</b>	Set the guard interval. A shorter interval can improve performance.
<b>802.11g Protection</b>	Enable/disable 802.11g protection, which increases reliability but reduces bandwidth (clients will send Request to Send (RTS) to AP, and AP will broadcast Clear to Send (CTS), before a packet is sent from client).
<b>802.11n Protection</b>	Enable/disable 802.11n protection, which increases reliability but reduces bandwidth (clients will send Request to Send (RTS) to AP, and AP will broadcast Clear to Send (CTS), before a packet is sent from client).
<b>DTIM Period</b>	Set the DTIM (delivery traffic indication message) period value of the wireless radio. The default value is 1.
<b>RTS Threshold</b>	Set the RTS threshold of the wireless radio. The default value is 2347.
<b>Fragment Threshold</b>	Set the fragment threshold of the wireless radio. The default value is 2346.
<b>Multicast Rate</b>	Set the transfer rate for multicast packets or use the “Auto” setting. The range of the transfer rate is between 1Mbps to 54Mbps
<b>Tx Power</b>	Set the power output of the wireless radio. You may not require 100% output power. Setting a lower power output may enhance security since access to your signal can be potentially prevented from malicious/unknown users in distant areas.
<b>Beacon Interval</b>	Set the beacon interval of the wireless radio. The default value is 100.
<b>Station idle timeout</b>	Set the interval for the AP to send keepalive messages to a wireless client to check if the station is still alive / active.

## Airtime Fairness

Airtime Fairness gives equal amounts of air time (instead of equal number of frames) to each client regardless of its theoretical data rate.

Set airtime fairness to “Auto”, “Static” or “Disable”.

When “Auto” is selected, the share rate is automatically managed.

When “Static” is selected, press “Edit SSID Rate” to enter a % for each SSID’s share rate as shown below:

Shared Rate for Airtime Fairness

#	SSID / WDS MAC address	Shared Rate	
1	XXXXXXXXXXXX	75	%
2	XXXXXXXXXXXX	20	%
3	XXXXXXXXXXXX	5	%

Apply Cancel

The % field has to add up to 100% or the system will display a message:

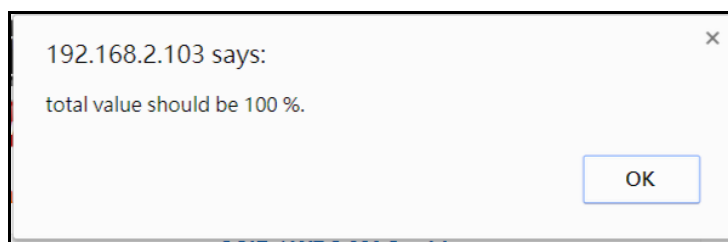

Airtime fairness is disabled if “Disable” is selected.

## Security:

The AP provides various security options (wireless data encryption). When data is encrypted, information transmitted wirelessly cannot be read by anyone who does not know the correct encryption key.



**It is essential to configure wireless security in order to prevent unauthorised access to your network.**

2.4GHz Wireless Security Settings	
SSID	<input type="text" value=""/>
Broadcast SSID	Enable ▾
Wireless Client Isolation	Disable ▾
802.11k	Disable ▾
Load Balancing	100 /100
Authentication Method	No Authentication ▾
Additional Authentication	No additional authentication ▾

2.4GHz Wireless Advanced Settings	
Smart Handover Settings	
Smart Handover	<input type="radio"/> Enable <input checked="" type="radio"/> Disable
RSSI Threshold	-80 ▾ dB

<b>SSID Selection</b>	Select a SSID to configure its security settings.
<b>Broadcast SSID</b>	<p>Enable or disable SSID broadcast.</p> <p>Enable: the SSID will be visible to clients as an available Wi-Fi network.</p> <p>Disable: the SSID will not be visible as an available Wi-Fi network to clients – clients must manually enter the SSID in order to connect. A hidden (disabled) SSID is typically more secure than a visible (enabled) SSID.</p>
<b>Wireless Client Isolation</b>	<p>Enable or disable wireless client isolation.</p> <p>Wireless client isolation prevents clients connected to the AP from communicating with each other and improves security. Typically, this function is useful for corporate environments or public hot spots and can prevent brute force attacks on clients' usernames and passwords.</p>
<b>Load Balancing</b>	Load balancing limits the number of wireless clients connected to an SSID. Set a load balancing value (maximum 100).
<b>Authentication Method</b>	Select an authentication method from the drop down menu and refer to the appropriate information below for your method.

### **No Authentication / Additional Authentication:**

When “No Authentication” is selected in “Authentication Method”, extra options are made available in the next line:

<b>Additional Authentication</b>	<p>Select an additional authentication method from the drop down menu or select “No additional authentication” for no authentication, where no password/key is required to connect to the AP.</p> <p>For other options, refer to the information below.</p>
----------------------------------	---



**“No additional authentication” is not recommended as anyone can connect to your device’s SSID.**

Additional wireless authentication methods can be applied to all authentication methods:



**WPS must be disabled to use additional authentication.**

### MAC Address Filter:

Restrict wireless clients access based on MAC address specified in the MAC filter table.

### MAC-RADIUS Authentication:

Restrict wireless clients access based on MAC address via a RADIUS server, or password authentication via a RADIUS server.



**WPS must be disabled to use MAC-RADIUS authentication.**

<b>Additional Authentication</b>	MAC RADIUS authentication ▼
<b>MAC RADIUS Password</b>	<input checked="" type="radio"/> Use MAC address <input type="radio"/> Use the following password <input type="text"/>

### MAC Filter & MAC-RADIUS Authentication:

Restrict wireless clients access using both of the above MAC filtering & RADIUS authentication methods.

<b>Additional Authentication</b>	MAC filter & MAC RADIUS authentication ▼
<b>MAC RADIUS Password</b>	<input checked="" type="radio"/> Use MAC address <input type="radio"/> Use the following password <input type="text"/>

<b>MAC RADIUS Password</b>	Select whether to use MAC address or password authentication via RADIUS server. If you select “Use the following password”, enter the password in the field below.
----------------------------	--

## WEP:

WEP (Wired Equivalent Privacy) is a basic encryption type. When selected, a notice will pop-up as exemplified below:

WPS 2.0 will be disabled if WEP is used.

Below is a figure showing the configurable fields:

Authentication Method	WEP ▼
Key Length	64-bit ▼
Key Type	ASCII (5Characters) ▼
Default Key	Key 1 ▼
Encryption Key 1	<input type="text"/>
Encryption Key 2	<input type="text"/>
Encryption Key 3	<input type="text"/>
Encryption Key 4	<input type="text"/>

<b>Key Length</b>	Select 64-bit or 128-bit. 128-bit is more secure than 64-bit and is recommended.
<b>Key Type</b>	Choose from “ASCII” (any alphanumerical character 0-9, a-z and A-Z) or “Hex” (any characters from 0-9, a-f and A-F).
<b>Default Key</b>	Select which encryption key (1 – 4 below) is the default key. For security purposes, you can set up to four keys (below) and change which is the default key.
<b>Encryption Key 1 – 4</b>	Enter your encryption key/password according to the format you selected above.

For a higher level of security, please consider using WPA encryption.

## IEEE802.1x/EAP:

Below is a figure showing the configurable fields:

Authentication Method	IEEE802.1x/EAP ▼
Key Length	64-bit ▼

<b>Key Length</b>	Select 64-bit or 128-bit. 128-bit is more secure than 64-bit and is recommended.
-------------------	--

## WPA-PSK:

WPA-PSK is a secure wireless encryption type with strong data protection and user authentication, utilizing 128-bit encryption keys.

Below is a figure showing the configurable fields:

Authentication Method	WPA-PSK ▼
802.11r Fast Roaming	<input checked="" type="radio"/> Enable <input type="radio"/> Disable
WPA Type	WPA/WPA2 Mixed Mode-PSK ▼
Encryption Type	TKIP/AES Mixed Mode ▼
Key Renewal Interval	60 minute(s)
Pre-shared Key Type	Passphrase ▼
Pre-shared Key	<input type="text"/>

Fast Roaming Settings will also be shown:

802.11r Fast Transition Roaming Settings	
mobility_domain	<input type="text"/>
Encryption Key	<input type="text"/>
Over the DS	<input type="radio"/> Enable <input checked="" type="radio"/> Disable

<b>802.11r Fast Roaming</b>	When your device roams from one AP to another on the same network, 802.11r uses a feature called Fast Basic Service Set Transition (FT) to authenticate more quickly. FT works with both preshared key (PSK) and 802.1X authentication methods.
<b>WPA Type</b>	Select from WPA/WPA2 Mixed Mode-PSK, WPA2 or WPA only. WPA2 is safer than WPA, but is not supported by all wireless clients. Please make sure your wireless client supports your selection.
<b>Encryption</b>	Select “TKIP/AES Mixed Mode” or “AES” encryption type.
<b>Key Renewal Interval</b>	Specify a frequency for key renewal in minutes.
<b>Pre-Shared Key Type</b>	Choose from “Passphrase” (8 – 63 alphanumeric characters) or “Hex” (up to 64 characters from 0-9, a-f and A-F).
<b>Pre-Shared Key</b>	Please enter a security key/password according to the format you selected above.

802.11r Fast Transition Roaming Settings	
<b>Mobility_domain</b>	Specify the mobility domain (2.4GHz or 5GHz)
<b>Encryption Key</b>	Specify the encryption key
<b>Over the DS</b>	Enable or disable this function.

## WPA-EAP:

Authentication Method	WPA-EAP ▼
802.11r Fast Roaming	<input checked="" type="radio"/> Enable <input type="radio"/> Disable
WPA Type	WPA/WPA2 mixed mode-EAP ▼
Encryption Type	TKIP/AES Mixed Mode ▼
Key Renewal Interval	60 minute(s)

Fast Roaming Settings will also be shown:

802.11r Fast Transition Roaming Settings	
mobility_domain	<input type="text"/>
Encryption Key	<input type="text"/>
Over the DS	<input type="radio"/> Enable <input checked="" type="radio"/> Disable

<b>WPA Type</b>	Select from WPA/WPA2 Mixed Mode-EAP, WPA2-EAP or WPA-EAP.
<b>Encryption Type</b>	Select “TKIP/AES Mixed Mode” or “AES” encryption type.
<b>Key Renewal Interval</b>	Specify a frequency for key renewal in minutes.



**WPA-EAP must be disabled to use MAC-RADIUS authentication.**

802.11r Fast Transition Roaming Settings	
<b>Mobility_domain</b>	Specify the mobility domain (2.4GHz or 5GHz)
<b>Encryption Key</b>	Specify the encryption key
<b>Over the DS</b>	Enable or disable this function.

## WDS:

Wireless Distribution System (WDS) can bridge/repeat APs together in an extended network. WDS settings can be configured as shown below.



**When using WDS, configure the IP address of each AP to be in the same subnet and ensure there is only one active DHCP server among connected APs, preferably on the WAN side.**

WDS must be configured on each AP, using correct MAC addresses. All APs should use the same wireless channel and encryption method.

## 2.4GHz

WDS Functionality	Disabled ▼
Local MAC Address	80:1F:02:F1:96:8A

## WDS Peer Settings

WDS #1	MAC Address	<input type="text"/>
WDS #2	MAC Address	<input type="text"/>
WDS #3	MAC Address	<input type="text"/>
WDS #4	MAC Address	<input type="text"/>

## WDS VLAN

VLAN Mode	Untagged Port ▼ (Enter at least one MAC address.)
VLAN ID	<input type="text" value="1"/>

## WDS Encryption method

Encryption	None ▼ (Enter at least one MAC address.)
------------	--

Apply Reset

2.4GHz	
<b>WDS Functionality</b>	Select “WDS with AP” to use WDS with AP or “WDS Dedicated Mode” to use WDS and also block communication with regular wireless clients. When WDS is used, each AP should be configured with corresponding MAC addresses, wireless channel and wireless encryption method.
<b>Local MAC Address</b>	Displays the MAC address of your AP.

WDS Peer Settings	
<b>WDS #</b>	Enter the MAC address for up to four other WDS devices you wish to connect.

WDS VLAN	
<b>VLAN Mode</b>	Specify the WDS VLAN mode to “Untagged Port” or “Tagged Port”.
<b>VLAN ID</b>	Specify the WDS VLAN ID when “Untagged Port” is selected above.

WDS Encryption method	
<b>Encryption</b>	Select whether to use “None” or “AES” encryption and enter a pre-shared key for AES consisting of 8-63 alphanumeric characters.

## Guest Network:

Enable / disable guest network to allow clients to connect as guests.



The screenshot shows a configuration window titled "Guest Network". It features a header bar with the title. Below the header, there are two rows of settings. The first row contains a color selection bar on the left and a dropdown menu on the right. The second row contains the text "Guest Network" on the left and two radio buttons labeled "Enable" and "Disable" on the right, with "Disable" being selected. At the bottom right of the window, there are two buttons: "Apply" and "Cancel".

### iii. 5GHz 11ac 11an

The "5GHz 11ac 11an" menu allows you to view and configure information for your AP's 5GHz wireless network across five categories: Basic, Advanced, Security, WDS & Guest Network.

#### Basic:

The "Basic" screen displays basic settings for your AP's 5GHz Wi-Fi network (s).

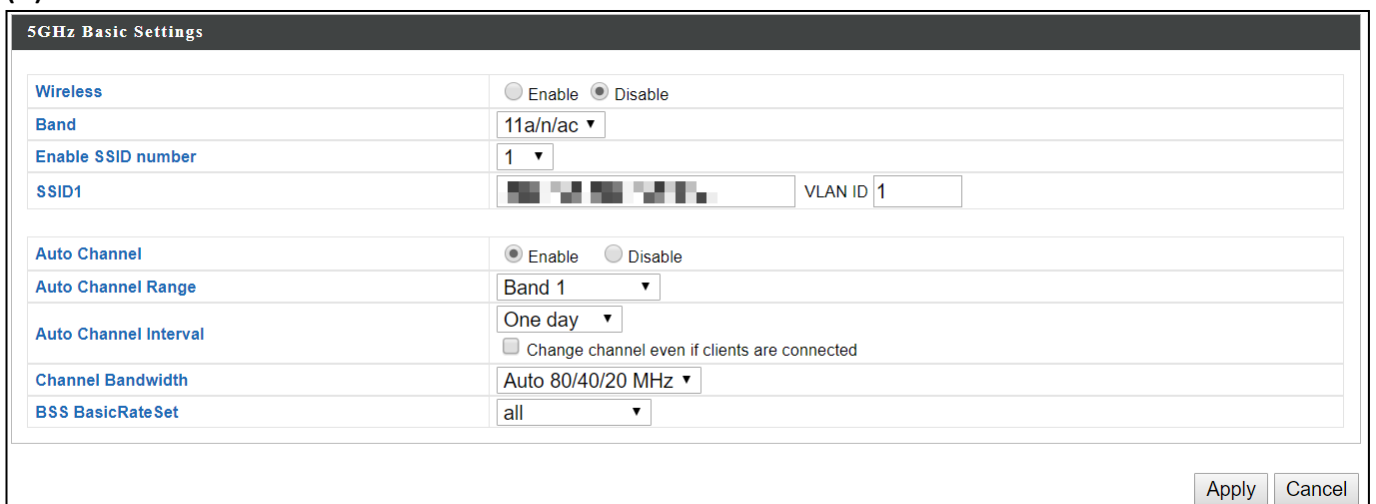

The screenshot shows a configuration window titled "5GHz Basic Settings". It contains several rows of settings. The first row is "Wireless" with radio buttons for "Enable" and "Disable", where "Disable" is selected. The second row is "Band" with a dropdown menu set to "11a/n/ac". The third row is "Enable SSID number" with a dropdown menu set to "1". The fourth row is "SSID1" with a color selection bar and a "VLAN ID" field set to "1". The fifth row is "Auto Channel" with radio buttons for "Enable" and "Disable", where "Enable" is selected. The sixth row is "Auto Channel Range" with a dropdown menu set to "Band 1". The seventh row is "Auto Channel Interval" with a dropdown menu set to "One day" and a checkbox for "Change channel even if clients are connected" which is unchecked. The eighth row is "Channel Bandwidth" with a dropdown menu set to "Auto 80/40/20 MHz". The ninth row is "BSS BasicRateSet" with a dropdown menu set to "all". At the bottom right of the window, there are two buttons: "Apply" and "Cancel".

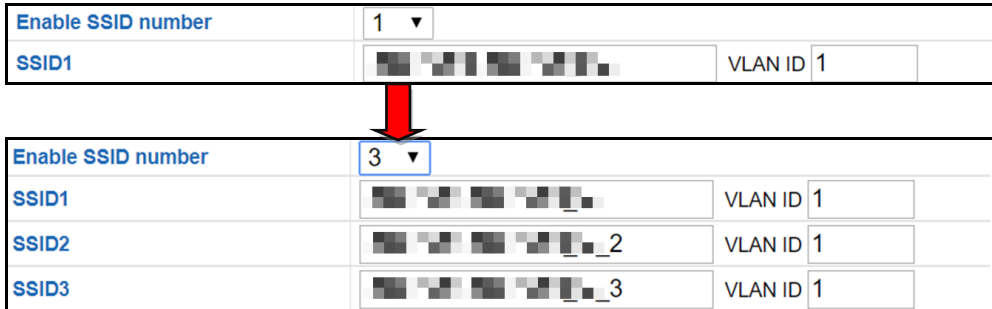
<b>Wireless</b>	Enable or disable the AP's 5GHz wireless radio. When disabled, no 5GHz SSIDs will be active.
<b>Band</b>	Wireless standard used for the AP. Combinations of 802.11a, 802.11n & 802.11ac can be selected.
<b>Enable SSID Number</b>	Select how many SSIDs to enable for the 2.4GHz frequency from the drop down menu. A maximum of 16 can be enabled. 
<b>SSID#</b>	Enter the SSID name for the specified SSID (up to 16). The SSID can consist of any combination of up to 32 alphanumeric characters.
<b>VLAN ID</b>	Specify a VLAN ID for each SSID.
<b>Auto Channel</b>	Enable/disable auto channel selection. Auto channel selection will automatically set the wireless channel for the AP's 5GHz frequency based on availability and potential interference. When disabled, configurable fields will change as shown below:
<b>Auto Channel Range</b>	Select a range to which auto channel selection can choose from.
<b>Auto Channel Interval</b>	Select a time interval for how often the auto channel setting will check/reassign the wireless channel. Check/uncheck the "Change channel even if clients are connected" box according to your preference.
<b>Channel Bandwidth</b>	Select the channel bandwidth: 20MHz (lower performance but less interference); or Auto 40/20 MHz; or Auto 80/40/20 MHz (automatically select based on interference level).
<b>BSS BasicRateSet</b>	Set a Basic Service Set (BSS) rate: this is a series of rates to control communication frames for wireless clients.

When auto channel is disabled, configurable fields will change. Select a wireless channel manually:

<b>Auto Channel</b>	<input checked="" type="radio"/> Enable <input type="radio"/> Disable
<b>Auto Channel Range</b>	Band 1 ▼
<b>Auto Channel Interval</b>	One day ▼ <input type="checkbox"/> Change channel even if clients are connected
<b>Channel Bandwidth</b>	Auto 80/40/20 MHz ▼
<b>BSS BasicRateSet</b>	all ▼



<b>Auto Channel</b>	<input type="radio"/> Enable <input checked="" type="radio"/> Disable
<b>Channel</b>	Ch 36, 5.18GHz ▼
<b>Channel Bandwidth</b>	Auto 80/40/20 MHz ▼
<b>BSS BasicRateSet</b>	all ▼

<b>Channel</b>	Select a wireless channel.
<b>Channel Bandwidth</b>	Select the channel bandwidth: <ul style="list-style-type: none"> <li>- 20MHz (lower performance but less interference)</li> <li>- Auto 40/20 MHz</li> <li>- Auto 80/40/20 MHz (automatically select based on interference level)</li> </ul>
<b>BSS BasicRateSet</b>	Set a Basic Service Set (BSS) rate: this is a series of rates to control communication frames for wireless clients.

## Advanced:

These settings are for experienced users only. Please do not change any of the values on this page unless you are already familiar with these functions.



**Changing these settings can adversely affect the performance of your AP.**

5GHz Advanced Settings	
Guard Interval	Short GI ▾
802.11n Protection	<input checked="" type="radio"/> Enable <input type="radio"/> Disable
DTIM Period	1 (1-255)
RTS Threshold	2347 (1-2347)
Fragment Threshold	2346 (256-2346)
Multicast Rate	Auto ▾
Tx Power	100% 21dbm ▾
Beacon Interval	100 (40-1000 ms)
Station Idle Timeout	60 (30-65535 seconds)
Beamforming	<input checked="" type="radio"/> Enable <input type="radio"/> Disable
Airtime Fairness	Disabled ▾ <a href="#">Edit SSID Rate</a>

[Apply](#) [Cancel](#)

<b>Guard Interval</b>	Set the guard interval. A shorter interval can improve performance.
<b>802.11n Protection</b>	Enable/disable 802.11n protection, which increases reliability but reduces bandwidth (clients will send Request to Send (RTS) to AP, and AP will broadcast Clear to Send (CTS), before a packet is sent from client.)
<b>DTIM Period</b>	Set the DTIM (delivery traffic indication message) period value of the wireless radio. (The default value is 1)
<b>RTS Threshold</b>	Set the RTS threshold of the wireless radio. (The default value is 2347)
<b>Fragment Threshold</b>	Set the fragment threshold of the wireless radio. (The default value is 2346)

<b>Multicast Rate</b>	Set the transfer rate for multicast packets or use the “Auto” setting.
<b>Tx Power</b>	Set the power output of the wireless radio. You may not require 100% output power. Setting a lower power output can enhance security since potentially malicious/unknown users in distant areas will not be able to access your signal.
<b>Beacon Interval</b>	Set the beacon interval of the wireless radio. The default value is 100.
<b>Station idle timeout</b>	Set the interval for keepalive messages from the AP to a wireless client to verify if the station is still alive/active.
<b>Beamforming</b>	Beamforming is a signal processing technique used in sensor arrays for directional signal transmission or reception. This is achieved by combining elements in an antenna array in such a way that signals at particular angles experience constructive interference while others experience destructive interference. Beamforming can be used at both the transmitting and receiving ends in order to achieve spatial selectivity. The improvement compared with omnidirectional reception / transmission is known as the directivity of the array.

## Airtime Fairness

Airtime Fairness gives equal amounts of air time (instead of equal number of frames) to each client regardless of its theoretical data rate.

Set airtime fairness to “Auto”, “Static” or “Disable”.

When “Auto” is selected, the share rate is automatically managed.

When “Static” is selected, press “Edit SSID Rate” to enter a % for each SSID’s share rate as shown below:

Shared Rate for Airtime Fairness

#	SSID / WDS MAC address	Shared Rate
1	XXXXXXXXXXXX	75 %
2	XXXXXXXXXXXX	20 %
3	XXXXXXXXXXXX	5 %

Apply Cancel

The % field has to add up to 100% or the system will display a message:

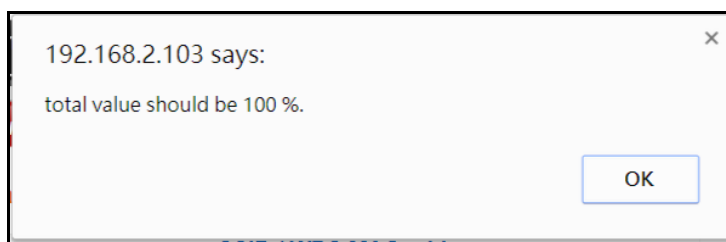

Airtime fairness is disabled if “Disable” is selected.

## Security:

The AP provides various security options (wireless data encryption). When data is encrypted, information transmitted wirelessly cannot be read by anyone who does not know the correct encryption key.



**It's essential to configure wireless security in order to prevent unauthorised access to your network.**

5GHz Wireless Security Settings	
SSID	<input type="text" value="XXXXXXXXXX"/>
Broadcast SSID	<input type="text" value="Enable"/>
Wireless Client Isolation	<input type="text" value="Disable"/>
802.11k	<input type="text" value="Disable"/>
Load Balancing	<input type="text" value="100"/> /100
Authentication Method	<input type="text" value="No Authentication"/>
Additional Authentication	<input type="text" value="No additional authentication"/>

5GHz Wireless Advanced Settings	
Smart Handover Settings	
Smart Handover	<input type="radio"/> Enable <input checked="" type="radio"/> Disable
RSSI Threshold	<input type="text" value="-80"/> dB

<b>SSID Selection</b>	Select which SSID to configure security settings for.
<b>Broadcast SSID</b>	Enable or disable SSID broadcast. When enabled, the SSID will be visible to clients as an available Wi-Fi network. When disabled, the SSID will not be visible as an available Wi-Fi network to clients – clients must manually enter the SSID in order to connect. A hidden (disabled) SSID is typically more secure than a visible (enabled) SSID.
<b>Wireless Client Isolation</b>	Enable or disable wireless client isolation. Wireless client isolation prevents clients connected to the AP from communicating with each other and improves security. Typically, this function is useful for corporate environments or public hot spots and can prevent brute force attacks on clients' usernames and passwords.
<b>Load Balancing</b>	Load balancing limits the number of wireless clients connected to an SSID. Set a load balancing value (maximum 100).
<b>Authentication Method</b>	Select an authentication method from the drop down menu.

## WDS:

Wireless Distribution System (WDS) can bridge/repeat APs together in an extended network. WDS settings can be configured as shown below.



**When using WDS, configure the IP address of each AP to be in the same subnet and ensure there is only one active DHCP server among connected APs, preferably on the WAN side.**

WDS must be configured on each AP, using correct MAC addresses. All APs should use the same wireless channel and encryption method.

5GHz WDS Mode	
WDS Functionality	Disabled ▼
Local MAC Address	80:1F:02:F1:96:8B
WDS Peer Settings	
WDS #1	MAC Address <input type="text"/>
WDS #2	MAC Address <input type="text"/>
WDS #3	MAC Address <input type="text"/>
WDS #4	MAC Address <input type="text"/>
WDS VLAN	
VLAN Mode	Untagged Port ▼ (Enter at least one MAC address.)
VLAN ID	1
Encryption method	
Encryption	None ▼ (Enter at least one MAC address.)
<input type="button" value="Apply"/> <input type="button" value="Reset"/>	

5GHz WDS Mode	
<b>WDS Functionality</b>	Select “WDS with AP” to use WDS with AP or “WDS Dedicated Mode” to use WDS and also block communication with regular wireless clients. When WDS is used, each AP should be configured with corresponding MAC addresses, wireless channel and wireless encryption method.
<b>Local MAC Address</b>	Displays the MAC address of your AP.

WDS Peer Settings	
<b>WDS #</b>	Enter the MAC address for up to four other WDA devices you wish to connect.

WDS VLAN	
<b>VLAN Mode</b>	Specify the WDS VLAN mode to “Untagged Port” or “Tagged Port”.
<b>VLAN ID</b>	Specify the WDS VLAN ID when “Untagged Port” is selected above.

WDS Encryption	
<b>Encryption</b>	Select whether to use “None” or “AES” encryption and enter a pre-shared key for AES with 8-63 alphanumeric characters.

### Guest Network:

Enable / disable guest network to allow clients to connect as guests.

The screenshot shows a configuration window titled "Guest Network". Inside the window, there is a section with a blue header "Guest Network". Below this header, there are two radio buttons: "Enable" and "Disable". The "Disable" radio button is selected. To the right of the radio buttons, there are two buttons: "Apply" and "Cancel".

#### iv. WPS

Wi-Fi Protected Setup is a simple way to establish connections between WPS compatible devices. WPS can be activated on compatible devices by pushing a WPS button on the compatible device or from within the compatible device's firmware / configuration interface (known as PBC or "Push Button Configuration"). When WPS is activated in the correct manner and at the correct time for two compatible devices, they will automatically connect. "PIN code WPS" is a variation of PBC which includes the additional use of a PIN code between the two devices for verification.

 **Please refer to the manufacturer's instructions of your WPS device.**

<b>WPS</b>		<input type="checkbox"/> Enable
<input type="button" value="Apply"/>		
<b>WPS</b>		
Product PIN	58327142	<input type="button" value="Generate PIN"/>
Push-button WPS	<input type="button" value="Start"/>	
WPS by PIN	<input type="text"/>	<input type="button" value="Start"/>
<b>WPS Security</b>		
WPS Status	Not Configured	<input type="button" value="Release"/>

<b>WPS</b>	Check/uncheck this box to enable/disable WPS functionality. WPS must be disabled when using MAC-RADIUS authentication.
------------	--

WPS	
<b>Product PIN</b>	Displays the WPS PIN code of the device, used for PIN code WPS. You will be required to enter this PIN code into another WPS device for PIN code WPS. Click “Generate PIN” to generate a new WPS PIN code.
<b>Push-Button WPS</b>	Click “Start” to activate WPS on the AP for approximately 2 minutes.
<b>WPS by PIN</b>	Enter the PIN code of another WPS device and click “Start” to attempt to establish a WPS connection. WPS function will last for approximately 2 minutes.

WPS Security	
<b>WPS Status</b>	WPS security status is displayed here. Click “Release” to clear the existing status.

## v. RADIUS

The RADIUS menu allows you to configure the AP's external RADIUS server settings.

A RADIUS server provides user-based authentication to improve security and offer wireless client control – users can be authenticated before gaining access to a network.

The AP can utilize a primary and a secondary (backup) external RADIUS server for each of its wireless frequencies (2.4GHz & 5GHz).

### RADIUS Settings:

Configure the RADIUS server settings for 2.4GHz and 5GHz. Each frequency can use an internal or external RADIUS server.

RADIUS Server (2.4GHz)	
<b>Primary RADIUS Server</b>	
RADIUS Type	<input type="radio"/> Internal <input checked="" type="radio"/> External
RADIUS Server	<input type="text"/>
Authentication Port	<input type="text" value="1812"/>
Shared Secret	<input type="text"/>
Session Timeout	<input type="text" value="3600"/> second(s)
Accounting	<input checked="" type="radio"/> Enable <input type="radio"/> Disable
Accounting Port	<input type="text" value="1813"/>
<b>Secondary RADIUS Server</b>	
RADIUS Type	<input type="radio"/> Internal <input checked="" type="radio"/> External
RADIUS Server	<input type="text"/>
Authentication Port	<input type="text" value="1812"/>
Shared Secret	<input type="text"/>
Session Timeout	<input type="text" value="3600"/> second(s)
Accounting	<input checked="" type="radio"/> Enable <input type="radio"/> Disable
Accounting Port	<input type="text" value="1813"/>

**RADIUS Server (5GHz)**

**Primary RADIUS Server**

RADIUS Type	<input type="radio"/> Internal <input checked="" type="radio"/> External
RADIUS Server	<input style="width: 90%;" type="text"/>
Authentication Port	<input style="width: 80%;" type="text" value="1812"/>
Shared Secret	<input style="width: 90%;" type="text"/>
Session Timeout	<input style="width: 80%;" type="text" value="3600"/> second(s)
Accounting	<input checked="" type="radio"/> Enable <input type="radio"/> Disable
Accounting Port	<input style="width: 80%;" type="text" value="1813"/>

**Secondary RADIUS Server**

RADIUS Type	<input type="radio"/> Internal <input checked="" type="radio"/> External
RADIUS Server	<input style="width: 90%;" type="text"/>
Authentication Port	<input style="width: 80%;" type="text" value="1812"/>
Shared Secret	<input style="width: 90%;" type="text"/>
Session Timeout	<input style="width: 80%;" type="text" value="3600"/> second(s)
Accounting	<input checked="" type="radio"/> Enable <input type="radio"/> Disable
Accounting Port	<input style="width: 80%;" type="text" value="1813"/>

<b>RADIUS Type</b>	Select “Internal” to use the AP’s built-in RADIUS server or “external” to use an external RADIUS server.
<b>RADIUS Server</b>	Enter the RADIUS server host IP address.
<b>Authentication Port</b>	Set the UDP port used in the authentication protocol of the RADIUS server.
<b>Shared Secret</b>	Enter a shared secret/password between 1 – 99 characters in length.
<b>Session Timeout</b>	Set a duration of session timeout in seconds between 0 – 86400.
<b>Accounting</b>	Enable or disable RADIUS accounting.
<b>Accounting Port</b>	When accounting is enabled (above), set the UDP port used in the accounting protocol of the RADIUS server.

## Internal Server:

The AP features a built-in RADIUS server which can be configured as shown below.

Internal Server	
Internal Server	<input type="checkbox"/> Enable
EAP Internal Authentication	<input type="text" value=""/>
EAP Certificate File Format	PKCS#12(*.pfx/*.p12)
EAP Certificate File	<input type="button" value="Upload"/>
Shared Secret	<input type="text" value=""/>
Session-Timeout	<input type="text" value="3600"/> second(s)
Termination-Action	<input type="radio"/> Reauthentication (RADIUS-Request) <input type="radio"/> Not-Reauthentication (Default) <input type="radio"/> Not-Send

<b>Internal Server</b>	Check/uncheck to enable/disable the AP's internal RADIUS server.
<b>EAP Internal Authentication</b>	Select EAP internal authentication type from the drop down menu.
<b>EAP Certificate File Format</b>	Displays the EAP certificate file format: PCK#12(*.pfx/*.p12)
<b>EAP Certificate File</b>	Click "Upload" to open a new window and select the location of an EAP certificate file to use. If no certificate file is uploaded, the internal RADIUS server will use a self-made certificate.
<b>Shared Secret</b>	Enter a shared secret/password for use between the internal RADIUS server and RADIUS client. The shared secret should be 1 – 99 characters in length.
<b>Session Timeout</b>	Set a duration of session timeout in seconds between 0 – 86400.
<b>Termination Action</b>	Select a termination-action attribute: Reauthentication: sends a RADIUS request to the AP Not-Reauthentication: sends a default termination-action attribute to the AP Not-Send: no termination-action attribute is sent to the AP.

## RADIUS Accounts:

The internal RADIUS server can authenticate up to 256 user accounts. The “RADIUS Accounts” page allows you to configure and manage users.

### RADIUS Accounts (Max: 256 users)

**User Name**

Example: USER1, USER2, USER3, USER4

### User Registration List

Select	User Name	Password	Customize
No user entries			

Enter a username in the box below and click “Add” to add the username. The webpage will display the message below:

You may press **CONTINUE** button to continue configuring other setting or press **APPLY** button to restart the system for changes to take effect.

If you choose to apply the settings (by clicking “Apply”), your system will restart the system with a message shown below:

Configuration is complete. Reloading now...  
Please wait for  seconds.

Press “Continue” to see the new user registration list.

User Registration List			
Select	User Name	Password	Customize
<input type="checkbox"/>	USER1	Not Configured	<input type="button" value="Edit"/>
<input type="button" value="Delete Selected"/>			<input type="button" value="Delete All"/>

Select “Edit” to edit the username and password of the RADIUS account:

Edit User Registration List	
<b>User Name</b>	<input type="text" value="USER1"/> (4-16Characters)
<b>Password</b>	<input type="text"/> (6-32Characters)
<input type="button" value="Apply"/> <input type="button" value="Cancel"/>	

<b>User Name</b>	Enter the user names here, separated by commas.
<b>Add</b>	Click “Add” to add the user to the user registration list.
<b>Reset</b>	Clear text from the user name box.

<b>Select</b>	Check the box to select a user.
<b>User Name</b>	Displays the user name.
<b>Password</b>	Displays if specified user name has a password (configured) or not (not configured).
<b>Customize</b>	Click “Edit” to open a new field to set/edit a password for the specified user name (below).

<b>Delete Selected</b>	Delete selected user from the user registration list.
<b>Delete All</b>	Delete all users from the user registration list.

## vi. MAC Filter

MAC filtering is a security feature that can help to prevent unauthorized users from connecting to your AP.

This function allows you to define a list of network devices permitted to connect to the AP. Devices are each identified by their unique MAC address. If a device which is not on the list of permitted MAC addresses attempts to connect to the AP, it will be denied.

The MAC address filtering table is displayed below:

**Add MAC Addresses**

**Enable Wireless Access Control**  Enable  Disable

**Wireless Access Control Mode** Blacklist ▼

---

**Add MAC Addresses**

<b>Add MAC Address</b>	Enter a MAC address of computer or network device manually e.g. 'aa-bb-cc-dd-ee-ff' or enter multiple MAC addresses separated with commas, e.g. 'aa-bb-cc-dd-ee-ff,aa-bb-cc-dd-ee-gg'
<b>Add</b>	Click "Add" to add the MAC address to the MAC address filtering table.
<b>Reset</b>	Clear all fields.

MAC address entries will be listed in the "MAC Address Filtering Table". Select an entry using the "Select" checkbox.

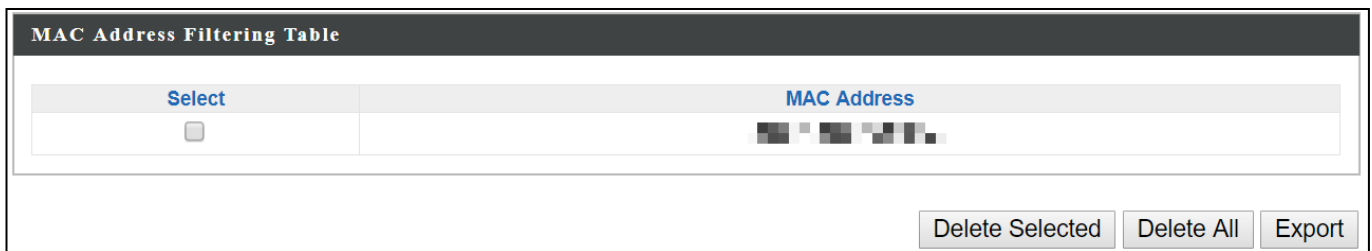

<b>Select</b>	Delete selected or all entries from the table.
<b>MAC Address</b>	The MAC address is listed here.
<b>Delete Selected</b>	Delete the selected MAC address from the list.
<b>Delete All</b>	Delete all entries from the MAC address filtering table.
<b>Export</b>	Click "Export" to save a copy of the MAC filtering table. A new window will pop up for you to select a location to save the file.

## vii. WMM

Wi-Fi Multimedia (WMM) is a Wi-Fi Alliance interoperability certification based on the IEEE 802.11e standard, which provides Quality of Service (QoS) features to IEEE 802.11 networks. WMM prioritizes traffic according to four categories: background, best effort, video and voice.

**WMM-EDCA Settings**

WMM Parameters of Access Point				
	CWMin	CWMax	AIFSN	TxOP
<b>Back Ground</b>	<input type="text" value="4"/>	<input type="text" value="10"/>	<input type="text" value="7"/>	<input type="text" value="0"/>
<b>Best Effort</b>	<input type="text" value="4"/>	<input type="text" value="6"/>	<input type="text" value="3"/>	<input type="text" value="0"/>
<b>Video</b>	<input type="text" value="3"/>	<input type="text" value="4"/>	<input type="text" value="1"/>	<input type="text" value="94"/>
<b>Voice</b>	<input type="text" value="2"/>	<input type="text" value="3"/>	<input type="text" value="1"/>	<input type="text" value="47"/>

WMM Parameters of Station				
	CWMin	CWMax	AIFSN	TxOP
<b>Back Ground</b>	<input type="text" value="4"/>	<input type="text" value="10"/>	<input type="text" value="7"/>	<input type="text" value="0"/>
<b>Best Effort</b>	<input type="text" value="4"/>	<input type="text" value="10"/>	<input type="text" value="3"/>	<input type="text" value="0"/>
<b>Video</b>	<input type="text" value="3"/>	<input type="text" value="4"/>	<input type="text" value="2"/>	<input type="text" value="94"/>
<b>Voice</b>	<input type="text" value="2"/>	<input type="text" value="3"/>	<input type="text" value="2"/>	<input type="text" value="47"/>

Configuring WMM consists of adjusting parameters on queues for different categories of wireless traffic. Traffic is sent to the following queues:

<b>Background</b>	Low Priority	High throughput, non time sensitive bulk data e.g. FTP
<b>Best Effort</b>	Medium Priority	Traditional IP data, medium throughput and delay.
<b>Video</b>	High Priority	Time sensitive video data with minimum time delay.
<b>Voice</b>	High Priority	Time sensitive data such as VoIP and streaming media with minimum time delay.

Queues automatically provide minimum transmission delays for video, voice, multimedia and critical applications. The values can be adjusted further manually:

<b>CWMin</b>	Minimum Contention Window (milliseconds): This value is input to the initial random backoff wait time algorithm for retry of a data frame transmission. The backoff wait time will be generated between 0 and this value. If the frame is not sent, the random backoff value is doubled until the value reaches the number defined by CWMax (below). The CWMin value must be lower than the CWMax value. The contention window scheme helps to avoid frame collisions and determine priority of frame transmission. A shorter window has a higher probability (priority) of transmission.
<b>CWMax</b>	Maximum Contention Window (milliseconds): This value is the upper limit to random backoff value doubling (see above).
<b>AIFSN</b>	Arbitration Inter-Frame Space (milliseconds): Specifies additional time between when a channel goes idle and the AP/client sends data frames. Traffic with a lower AIFSN value has a higher priority.
<b>TxOP</b>	Transmission Opportunity (milliseconds): The maximum interval of time an AP/client can transmit. This makes channel access more efficiently prioritized. A value of 0 means only one frame per transmission. A greater value means higher priority.

## viii. Schedule

The schedule feature allows you to automate the wireless network for the specified time ranges. Wireless scheduling can save energy and increase the security of your network.

Enable the wireless network during the following schedules.

This function will not work until date and time are set. [Settings](#)

Schedule  Enable

[Apply](#)

### Schedule List

#	SSID	Day of Week	Time	Select
No schedule entries				

[Add](#) [Edit](#) [Delete Selected](#) [Delete All](#)

1. Select “Add” to add a schedule.  
The webpage will display the message below:

You may press CONTINUE button to continue configuring other setting or press APPLY button to restart the system for changes to take effect.

[Apply](#) [Continue](#)

If you choose to apply the settings (by clicking “Apply”), your system will restart the system with a message shown below:

Configuration is complete. Reloading now...

Please wait for  seconds.

- Settings page will be shown if “Continue” is selected:  
 Check/uncheck the box of the desired SSID network, day of schedule and select the Start Time and End Time (using the dropdown menu).  
 Select “Apply” to apply the settings, or “Cancel” to forfeit the schedule.

**Settings**

2.4GHz SSID		5GHz SSID	
<input type="checkbox"/>	[Redacted SSID]	<input type="checkbox"/>	[Redacted SSID]
<input type="checkbox"/>	[Redacted SSID]		

Sun.	Mon.	Tue.	Wed.	Thu.	Fri.	Sat.
<input type="checkbox"/>	<input type="checkbox"/>	<input type="checkbox"/>	<input type="checkbox"/>	<input type="checkbox"/>	<input type="checkbox"/>	<input type="checkbox"/>

Start Time
00 ▾ : 00 ▾
End Time
00 ▾ : 00 ▾

Schedules will be shown in the Schedule List as exemplified below:

**Schedule List**

#	SSID	Day of Week	Time	Select
1	[Redacted SSID]	Mon.	07:00-16:00	<input type="checkbox"/>

## VI-9. Local Settings

### i. Operation Mode

The AP can function in five different modes. Set the operation mode of the AP here.

1. AP Mode: The device acts as a standalone AP
2. AP controller Mode: The device acts as the designated master of the AP array
3. Managed AP Mode: The device acts as a slave AP within the AP array.

The screenshot shows a configuration window with three main sections: **Operation Mode**, **Wireless Mode**, and **Management**. In the **Operation Mode** section, the 'Operation Mode' dropdown is set to 'AP Controller Mode'. In the **Wireless Mode** section, both '2.4GHz Mode' and '5GHz Mode' dropdowns are set to 'Access Point'. In the **Management** section, the 'Self AP Management Mode' dropdown is set to 'Disable'. At the bottom right, there are 'Apply' and 'Cancel' buttons.

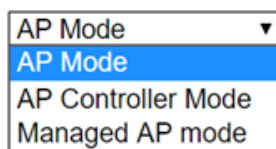

**In Managed AP mode some functions of the AP will be disabled in this user interface and must be set using Edimax Pro NMS on the AP Controller.**





**In AP Controller Mode the AP will switch to the Edimax Pro NMS user interface.**

# System Information:

“System Information” page displays basic system information.

**System**

Model	
Product Name	AP801F02F1968A
Uptime	1 day 23:51:09
System Time	 /01/02 23:53:07
Boot from	Internal memory
Firmware Version	1.8.1
MAC Address	80:1F:02:F1:96:8A
Management VLAN ID	1
IP Address	192.168.2.103 <input type="button" value="Refresh"/>
Default Gateway	192.168.2.70
DNS	192.168.2.70
DHCP Server	192.168.2.70



**Wired LAN Port Settings**

Wired LAN Port	Status	VLAN Mode/ID
LAN1	Connected (100 Mbps Full-Duplex)	Untagged Port / 1
LAN2	Disconnected (--)	Untagged Port / 1

**Wireless 2.4GHz**

Status	Enabled
MAC Address	80:1F:02:F1:96:8A
Channel	Ch 7 (Auto)
Transmit Power	100% 28dbm
RSSI	-63/-79/-80

**Wireless 2.4GHz /SSID**

SSID	Authentication Method	Encryption Type	VLAN ID	Additional Authentication	Wireless Client Isolation
	No Authentication	No Encryption	1	No additional authentication	Disabled
	No Authentication	No Encryption	1	No additional authentication	Disabled

**Wireless 2.4GHz /WDS Disabled**

MAC Address	Encryption Type	VLAN Mode/ID
No WDS entries.		

**Wireless 5GHz**

Status	Enabled
MAC Address	80:1F:02:F1:96:8B
Channel	Ch 36 + 40 + 44 + 48 (Auto)
Transmit Power	100% 24dbm
RSSI	0/0

**Wireless 5GHz /SSID**

SSID	Authentication Method	Encryption Type	VLAN ID	Additional Authentication	Wireless Client Isolation
	No Authentication	No Encryption	1	No additional authentication	Disabled

**Wireless 5GHz /WDS Disabled**

MAC Address	Encryption Type	VLAN Mode/ID
No WDS entries.		

System	
<b>Model</b>	Displays the model number of the AP.
<b>Product Name</b>	Displays the product name for reference, which consists of "AP" plus the MAC address.
<b>Uptime</b>	Displays the total time since the device was turned on.
<b>System Time</b>	Displays the system time.
<b>Boot From</b>	Displays information for the booted hardware, booted from internal memory.
<b>Firmware Version</b>	Displays the firmware version.
<b>MAC Address</b>	Displays the AP's MAC address.
<b>Management VLAN ID</b>	Displays the management VLAN ID.
<b>IP Address</b>	Displays the IP address of this device. Click "Refresh" to update this value.
<b>Default Gateway</b>	Displays the IP address of the default gateway.
<b>DNS</b>	IP address of DNS (Domain Name Server)
<b>DHCP Server</b>	IP address of DHCP Server.

Wired LAN Port Settings	
<b>Wired LAN Port</b>	Specifies which LAN port (1 or 2).
<b>Status</b>	Displays the status of the specified LAN port (connected or disconnected).
<b>VLAN Mode/ID</b>	Displays the VLAN mode (tagged or untagged) and VLAN ID for the specified LAN port.

Wireless 2.4GHz (5GHz)	
<b>Status</b>	Displays the status of the 2.4GHz or 5GHz wireless (enabled or disabled).
<b>MAC Address</b>	Displays the AP's MAC address.
<b>Channel</b>	Displays the channel number the specified wireless frequency is using for broadcast.
<b>Transmit Power</b>	Displays the wireless radio transmit power level as a percentage.
<b>RSSI</b>	Received signal strength indicator (RSSI) is a measurement of the power present in a received radio signal.

Wireless 2.4GHZ (5GHz) / SSID	
<b>SSID</b>	Displays the SSID name(s) for the specified frequency.
<b>Authentication Method</b>	Displays the authentication method for the specified SSID.
<b>Encryption Type</b>	Displays the encryption type for the specified SSID.
<b>VLAN ID</b>	Displays the VLAN ID for the specified SSID.
<b>Additional Authentication</b>	Displays the additional authentication type for the specified SSID.
<b>Wireless Client Isolation</b>	Displays whether wireless client isolation is in use for the specified SSID.

Wireless 2.4GHZ (5GHz) / WDS Status	
<b>MAC Address</b>	Displays the peer AP's MAC address.
<b>Encryption Type</b>	Displays the encryption type for the specified WDS.
<b>VLAN Mode/ID</b>	Displays the VLAN ID for the specified WDS.

## Wireless Clients:

“Wireless Clients” page displays information about all wireless clients connected to the AP on the 2.4GHz or 5GHz frequency.

Refresh Time	
Auto Refresh Time	<input checked="" type="radio"/> 5 seconds <input type="radio"/> 1 second <input type="radio"/> Disable
Manual Refresh	<input type="button" value="Refresh"/>

2.4GHz WLAN Client Table											
#	SSID	IP Address	MAC Address	Tx	Rx	Signal (%)	RSSI (dbm)	Connected Time	Idle Time	Vendor	Kick
No wireless client											

5GHz WLAN Client Table											
#	SSID	IP Address	MAC Address	Tx	Rx	Signal (%)	RSSI (dbm)	Connected Time	Idle Time	Vendor	Kick
No wireless client											

Refresh time	
<b>Auto Refresh Time</b>	Select a time interval for the client table list to automatically refresh.
<b>Manual Refresh</b>	Click refresh to manually refresh the client table.

2.4GHz (5GHz) WLAN Client Table	
<b>SSID</b>	Displays the SSID which the client is connected to.
<b>MAC Address</b>	Displays the MAC address of the client.
<b>Tx</b>	Displays the total data packets transmitted by the specified client.
<b>Rx</b>	Displays the total data packets received by the specified client.
<b>Signal (%)</b>	Displays the wireless signal strength for the specified client.
<b>Connected Time</b>	Displays the total time the wireless client has been connected to the AP.
<b>Idle Time</b>	Client idle time is the time for which the client has not transmitted any data packets i.e. is idle.
<b>Vendor</b>	The vendor of the client’s wireless adapter is displayed here.

## Wireless Monitor:

“Wireless Monitor” is a tool built into the AP to scan and monitor the surrounding wireless environment. Select a frequency and click “Scan” to display a list of all SSIDs within range along with relevant details for each SSID.

Wireless Monitor	
<b>Site Survey</b>	Select which frequency (or both) to scan, and click “Scan” to begin.
<b>Channel Survey Result</b>	After a scan is complete, click “Export” to save the results to local storage.

Site Survey Results	
<b>Ch</b>	Displays the channel number used by the specified SSID.
<b>SSID</b>	Displays the SSID identified by the scan.
<b>MAC Address</b>	Displays the MAC address of the wireless router/AP for the specified SSID.
<b>Security</b>	Displays the authentication/encryption type of the specified SSID.
<b>Signal (%)</b>	Displays the current signal strength of the SSID.
<b>Type</b>	Displays the 802.11 wireless networking standard(s) of the specified SSID.
<b>Vendor</b>	Displays the vendor of the wireless router/AP for the specified SSID.

## Log:

“System log” displays system operation information such as up time and connection processes. This information is useful for network administrators.



**Older entries will be overwritten when the log is full**

All Events/Activities					
Search <input type="text"/> <input type="checkbox"/> Match whole words					
ID	Date and Time	Category	Severity	Users	Events/Activities
186	/01/03 01:00:52	DHCPC	Low	admin	DHCP Client, Lease obtained: 192.168.2.103; lease time 3600
185	/01/03 00:30:52	DHCPC	Low	admin	DHCP Client, Lease obtained: 192.168.2.103; lease time 3600
184	/01/03 00:00:52	DHCPC	Low	admin	DHCP Client, Lease obtained: 192.168.2.103; lease time 3600
183	/01/02 23:30:52	DHCPC	Low	admin	DHCP Client, Lease obtained: 192.168.2.103; lease time 3600
182	/01/02 23:00:51	DHCPC	Low	admin	DHCP Client, Lease obtained: 192.168.2.103; lease time 3600
181	/01/02 22:30:51	DHCPC	Low	admin	DHCP Client, Lease obtained: 192.168.2.103; lease time 3600
180	/01/02 22:00:51	DHCPC	Low	admin	DHCP Client, Lease obtained: 192.168.2.103; lease time 3600
179	/01/02 21:30:51	DHCPC	Low	admin	DHCP Client, Lease obtained: 192.168.2.103; lease time 3600
178	/01/02 21:00:51	DHCPC	Low	admin	DHCP Client, Lease obtained: 192.168.2.103; lease time 3600
177	/01/02 20:36:40	SYSTEM	Low	admin	WLAN[5G], Best channel selection start, switch to channel 36 + 40 + 44 + 48
176	/01/02 20:36:29	SYSTEM	Low	admin	Bandsteering, Stopping
175	/01/02 20:36:18	SYSTEM	Low	admin	Bandsteering, Stopping
174	/01/02 20:36:18	SYSTEM	Low	admin	Traffic Shaping ssid, Stopping
173	/01/02 20:36:18	SYSTEM	Low	admin	SNMP, start SNMP server
172	/01/02 20:36:18	SYSTEM	Low	admin	SNMP, stop SNMP server
171	/01/02 20:36:18	SYSTEM	Low	admin	LAN, Firewall Disabled
170	/01/02 20:36:18	SYSTEM	Low	admin	LAN, NAT Disabled
169	/01/02 20:36:18	SYSTEM	Low	admin	LAN, stop Firewall
168	/01/02 20:36:18	SYSTEM	Low	admin	LAN, stop NAT
167	/01/02 20:36:18	SYSTEM	Low	admin	SCHEDULE, Schedule Stopping

Save Clear Refresh ◀ 186-167 ▶

<b>Save</b>	Click to save the log as a file on your local computer.
<b>Clear</b>	Clear all log entries.
<b>Refresh</b>	Refresh the current log.

The following information/events are recorded by the log:

<b>Log (Category)</b>	
<b>USB</b>	Mount & un-mount
<b>Wireless Client</b>	Connected & disconnected Key exchange success & fail
<b>Authentication</b>	Authentication fail or successful
<b>Association</b>	Success or fail
<b>WPS</b>	M1 - M8 messages WPS success
<b>Change Settings</b>	Displays the total time the wireless client has been connected to the AP
<b>System Boot</b>	Displays current model name
<b>Vendor</b>	The vendor of the client's wireless adapter is displayed here
<b>NTP Client</b>	Syncing time with NTP server
<b>Wired Link</b>	LAN Port link status and speed status
<b>Proxy ARP</b>	Proxy ARP module start & stop
<b>Bridge</b>	Bridge start & stop
<b>SNMP</b>	SNMP server start & stop
<b>HTTP</b>	HTTP start & stop
<b>HTTPS</b>	HTTPS start & stop
<b>SSH</b>	SSH-client server start & stop
<b>Telnet</b>	Telnet-client server start or stop
<b>WLAN (2.4G) and (5G)</b>	WLAN (2.4G) and (5G) channel status and country/region status

## ii. Management

### Admin:

You can change the password used to login to the browser-based configuration interface here. It is advised to do so for security purposes.

 **If you change the administrator password, please make a note of the new password. In the event that you forget this password and are unable to login to the browser based configuration interface.**

Account to Manage This Device	
Administrator Name	<input type="text" value="admin"/>
Administrator Password	<input type="password" value="....."/> (4-32Characters)
	<input type="password" value="....."/> (Confirm)
<input type="button" value="Apply"/>	

Advanced Settings	
Product Name	<input type="text" value="AP801F02F1968A"/>
HTTP Port	<input type="text" value="80"/> (80, 1024-65535)
HTTPS Port	<input type="text" value="443"/> (443, 1024-65535)
Management Protocol	<input checked="" type="checkbox"/> HTTP <input checked="" type="checkbox"/> HTTPS <input checked="" type="checkbox"/> TELNET <input type="checkbox"/> SSH
Login Timeout	<input type="text" value="5"/> (mins)
<input type="button" value="Apply"/>	

Account to Manage This Device	
<b>Administrator Name</b>	Set the AP's administrator name. This is used to log in to the browser based configuration interface and must be between 4-16 alphanumeric characters (case sensitive).
<b>Administrator Password</b>	Set the AP's administrator password. This is used to log in to the browser based configuration interface and must be between 4-32 alphanumeric characters (case sensitive).

Advanced Settings	
<b>Product Name</b>	Edit the product name according to your preference consisting of 1-32 alphanumeric characters. This name is used for reference purposes.
<b>Management Protocol</b>	Check/uncheck the boxes to enable/disable specified management interfaces (see below). When SNMP is enabled, complete the SNMP fields below.
<b>SNMP Version</b>	Select SNMP version appropriate for your SNMP manager.
<b>SNMP Get Community</b>	Enter an SNMP Get Community name for verification with the SNMP manager for SNMP-GET requests.
<b>SNMP Set Community</b>	Enter an SNMP Set Community name for verification with the SNMP manager for SNMP-SET requests.
<b>SNMP Trap</b>	Enable or disable SNMP Trap to notify SNMP manager of network errors.
<b>SNMP Trap Community</b>	Enter an SNMP Trap Community name for verification with the SNMP manager for SNMP-TRAP requests.
<b>SNMP Trap Manager</b>	Specify the IP address or sever name (2-128 alphanumeric characters) of the SNMP manager.

## Date and Time:

Configure the date and time settings of the AP here. The date and time of the device can be configured manually or can be synchronized with a time server.

**Date and Time Settings**

**Local Time**

2012 ▼ Year
Jan ▼ Month
1 ▼ Day

0 ▼ Hours
00 ▼ Minutes
00 ▼ Seconds

Acquire Current Time from Your PC

**NTP Time Server**

**Use NTP**

Enable

**Auto Daylight Saving**

Enable

**Server Name**

User-Defined ▼

**Update Interval**

24 (Hours)

**Time Zone**

**Time Zone**

(GMT+08:00) Taipei, Taiwan ▼

Date and Time Settings	
<b>Local Time</b>	Set the AP's date and time manually using the drop down menus.
<b>Acquire Current Time from your PC</b>	Click "Acquire Current Time from Your PC" to enter the required values automatically according to your computer's current time and date.

NTP Time Server	
<b>Use NTP</b>	The AP also supports NTP (Network Time Protocol) for automatic time and date setup.
<b>Server Name</b>	Enter the host name or IP address of the time server if you wish.
<b>Update Interval</b>	Specify a frequency (in hours) for the AP to update/synchronize with the NTP server.

Time Zone	
<b>Time Zone</b>	Select the time zone of your country/region. If your country/region is not listed, please select another country/region whose time zone is the same as yours.

Press “Apply” to apply the configuration, or “Cancel” to forfeit the changes.

### Syslog Server Settings:

The system log can be sent to a server.

Syslog Server Settings	
<b>Transfer Logs</b>	Check the box to enable the use of a syslog server. Enter a host name, domain or IP address for the server, consisting of up to 128 alphanumeric characters.

## Syslog E-mail Settings:

Syslog E-mail Settings	
E-mail Logs	<input type="checkbox"/>
E-mail Subject	<input type="text"/>
SMTP Server Address	<input type="text"/>
SMTP Server Port	<input type="text"/>
Sender E-mail	<input type="text"/>
Receiver E-mail	<input type="text"/>
Authentication	Disable ▾

Syslog E-mail Settings	
<b>E-mail Logs</b>	Check the box to enable/disable e-mail logs.
<b>E-mail Subject</b>	Specify the subject line of log emails.
<b>SMTP Server Address</b>	Specify the SMTP server address used to send log emails.
<b>SMTP Server Port</b>	Specify the SMTP server port used to send log emails.
<b>Sender E-mail</b>	Specify the sender email address.
<b>Receiver E-mail</b>	Specify the email to receive log emails.
<b>Authentication</b>	Disable or select authentication type: SSL or TLS. When using SSL or TLS, enter the username and password.

## iv. Advanced

### LED Settings:

The AP's LEDs can be manually enabled or disabled according to your preference.

LED Settings	
Power LED	<input checked="" type="radio"/> On <input type="radio"/> Off
Diag LED	<input checked="" type="radio"/> On <input type="radio"/> Off

Apply Cancel

<b>Power LED</b>	Select on or off.
<b>Diag LED</b>	Select on or off.

## Update Firmware:

The “Firmware” page allows you to update the firmware of the system. Updated firmware versions often offer increased performance and security, as well as bug fixes. Download the latest firmware from the Edimax website.

**Firmware Location**

Update firmware from  a file on your PC

---

**Update Firmware from PC**

Firmware Update File  No file chosen



**Do not switch off or disconnect the AP during a firmware upgrade, as this could damage the device.**

<b>Firmware Location</b>	Click “Choose File” to upload firmware from your local computer.
--------------------------	--

## Save/Restore Settings:

The device's "Save / Restore Settings" page enables you to save / backup the device's current settings as a file to your local computer, and restore the AP to previously saved settings.

The screenshot shows a web interface for saving and restoring settings. It is divided into three main sections:

- Save/Restore Method:** A radio button selection where "Using your PC" is selected.
- Save Settings to PC:** A "Save Settings" link, a checkbox for "Encrypt the configuration file with a password" (unchecked), a password input field, and a "Save" button.
- Restore Settings from PC:** A "Restore Settings" link, a "Choose File" button (showing "No file chosen"), a checkbox for "Open file with password" (unchecked), a password input field, and a "Restore" button.

### Save Settings to PC

#### Save Settings

Encryption: If you wish to encrypt the configuration file with a password, check the "Encrypt the configuration file with a password" box and enter a password. Click "Save" to save current settings. A new window will open to allow you to specify a location to save to.

### Restore Settings from PC

#### Restore Settings

Click the "Choose File" button to find a previously saved settings file on your computer. If your settings file is encrypted with a password, check the "Open file with password" box and enter the password in the following field. Click "Restore" to replace your current settings.

## Factory Default:

If the AP malfunctions or is not responding, rebooting the device maybe an option to consider. If rebooting does not work, try resetting the device back to its factory default settings. You can reset the AP back to its default settings using this feature if the reset button is not accessible.

This will restore all settings to factory defaults.

Factory Default

<b>Factory Default</b>	Click “Factory Default” to restore settings to the factory default. A pop-up window will appear and ask you to confirm.
------------------------	---



**After resetting to factory defaults, please wait for the AP to reset and restart.**

## Reboot:

If the AP malfunctions or is not responding, rebooting the device may be an option to consider. You can reboot the AP remotely using this feature.

This will reboot the product. Your settings will not be changed. Click "Reboot" to reboot the product now.

Reboot

### Reboot

Click "Reboot" to reboot the device. A countdown will indicate the progress of the reboot.

## VI-10. Toolbox

The Toolbox panel provides network diagnostic tools: Ping, Traceroute, and IP Scan.

### i. Network Connectivity

#### Ping:

Ping is a computer network administration utility used to test whether a particular host is reachable across an IP network and to measure the round-trip time for sent messages.

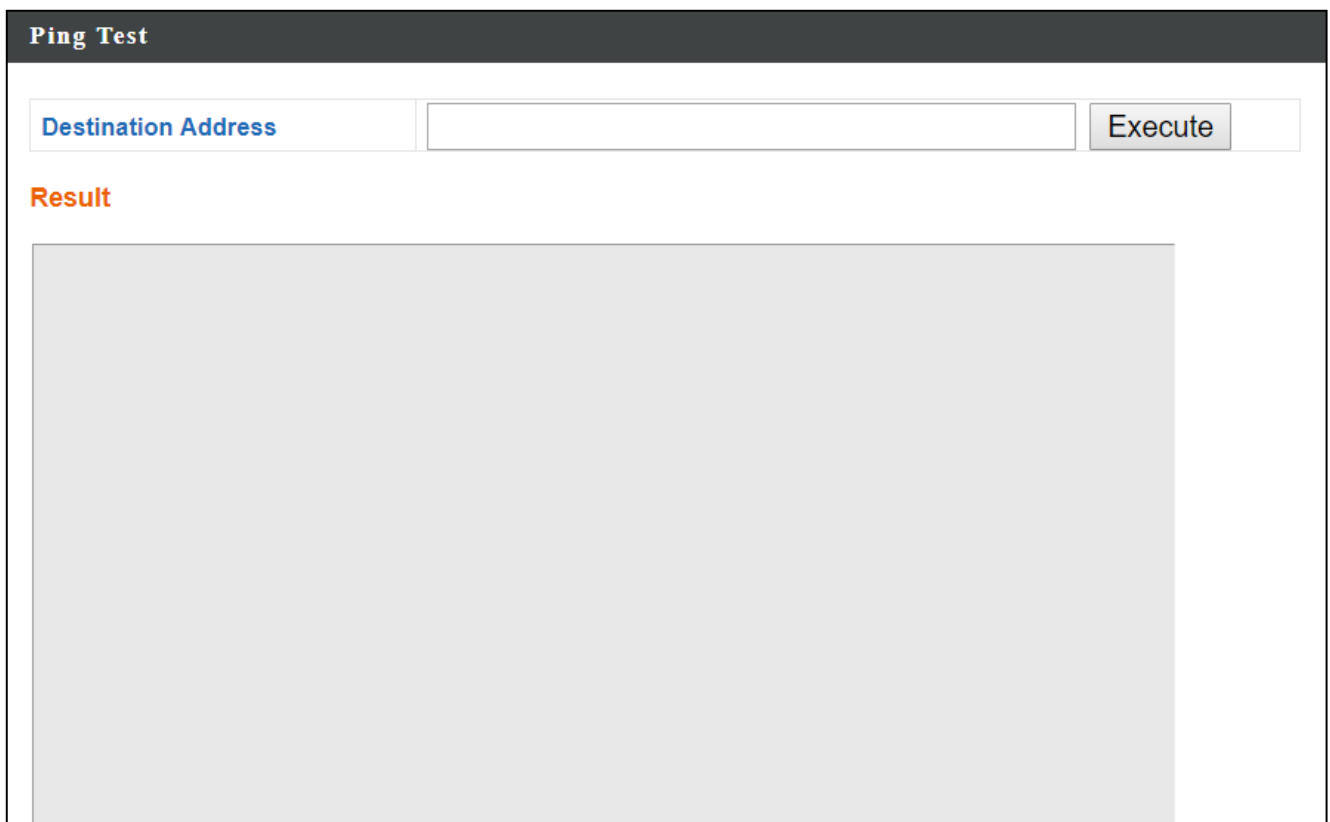

The screenshot shows a web-based interface for a 'Ping Test' tool. At the top, there is a dark header with the text 'Ping Test'. Below the header, there is a form with a text input field labeled 'Destination Address' and a button labeled 'Execute'. Below the form, there is a section labeled 'Result' with a large, empty gray rectangular area for displaying the test results.

<b>Destination Address</b>	Enter the address of the host.
<b>Execute</b>	Click "Execute" to ping the host.

## Trace Route:

Traceroute is a diagnostic tool for displaying the route (path) and measuring transit delays of packets across an IP network.

**Traceroute Test**

Destination Address  Execute

**Result**

[Large grey placeholder area]

<b>Destination Address</b>	Enter the address of the host.
<b>Execute</b>	Click "Execute" to execute the traceroute command.

## IP Scan:

**IP Scan**

IP domain  .  .  \* scan

**Result**

Graphic Illustration:  un-used  distributed  non-distributable  scanning

	0	1	2	3	4	5	6	7	8	9	10	11	12	13	14	15	16	17	18	19	20	21	22	23	24	25	26	27	28	29	30	31
0-31																																
32-63																																
64-95																																
96-127																																
128-159																																
160-191																																
192-223																																
224-255																																

## VII. WPS

---

WPS is a simple way to establish connections between WPS compatible devices. You can use the WPS button on CAX1800 webpage to activate the AP's WPS function.

1. Go to "Wireless Settings".
2. Tap "WPS".
3. Check the checkbox of "Enable" and click "Apply" to turn on WPS function.
4. Click Start to establish connections between WPS compatible devices.

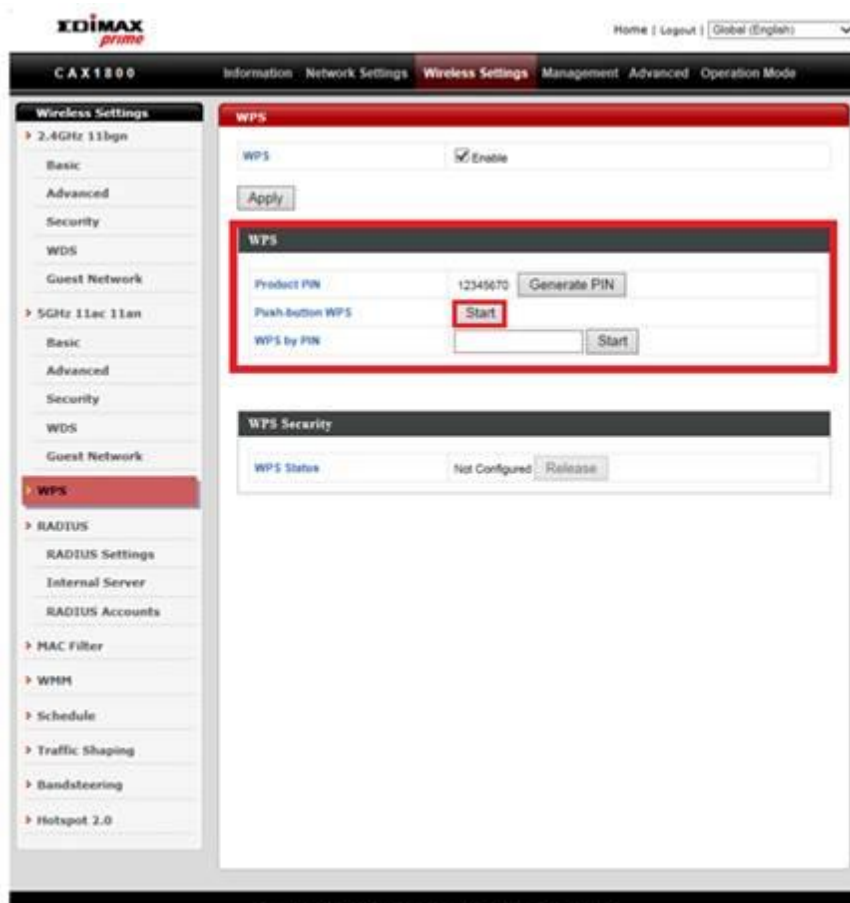

5. Within two minutes, press the WPS button to activate WPS on your WPS-compatible wireless device.

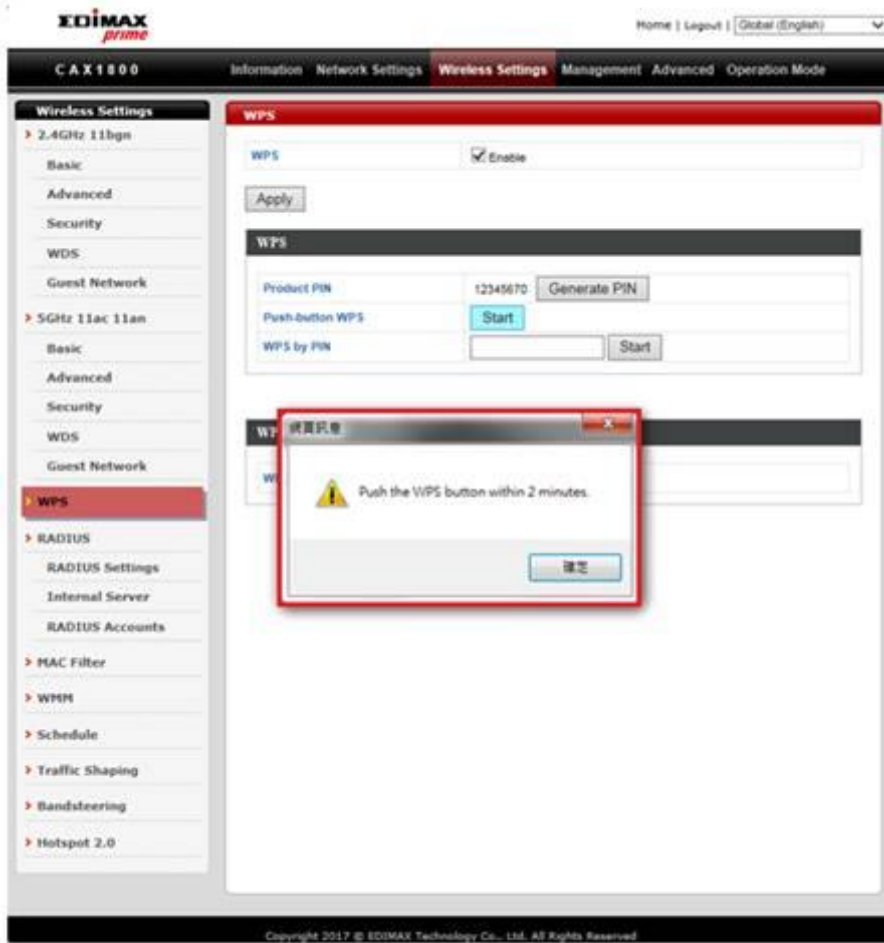

## VIII. Reset

If you experience problems with your AP, you can reset the device back to its factory settings.

1. Press and hold the reset button on the AP for at least 10 seconds then release the button.



**You may need to use a pin or similar sharp object to push the reset button.**

2. Wait for the AP to restart. The AP is ready for setup when the LED is **Blue**.

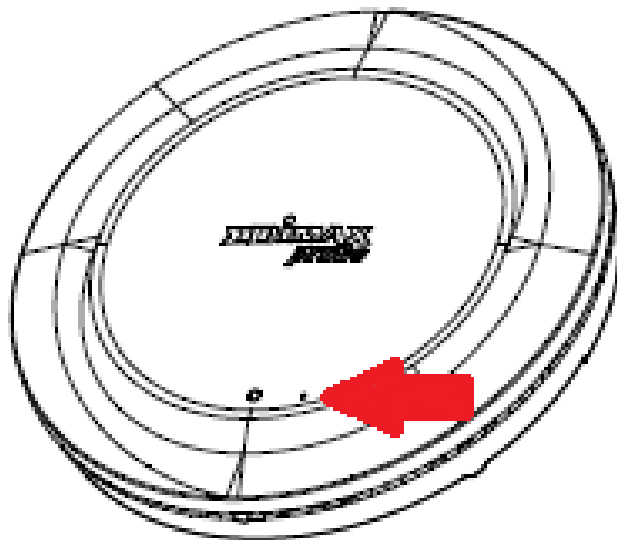

## COPYRIGHT

Copyright © Edimax Technology Co., Ltd. all rights reserved. No part of this publication may be reproduced, transmitted, transcribed, stored in a retrieval system, or translated into any language or computer language, in any form or by any means, electronic, mechanical, magnetic, optical, chemical, manual or otherwise, without the prior written permission from Edimax Technology Co., Ltd.

Edimax Technology Co., Ltd. makes no representations or warranties, either expressed or implied, with respect to the contents hereof and specifically disclaims any warranties, merchantability, or fitness for any particular purpose. Any software described in this manual is sold or licensed as is. Should the programs prove defective following their purchase, the buyer (and not this company, its distributor, or its dealer) assumes the entire cost of all necessary servicing, repair, and any incidental or consequential damages resulting from any defect in the software. Edimax Technology Co., Ltd. reserves the right to revise this publication and to make changes from time to time in the contents hereof without the obligation to notify any person of such revision or changes.

The product you have purchased and the setup screen may appear slightly different from those shown in this QIG. The software and specifications are subject to change without notice. Please visit our website [www.edimax.com](http://www.edimax.com) for updates. All brand and product names mentioned in this manual are trademarks and/or registered trademarks of their respective holders.

	AT	BE	BG	HR	CY	CZ	DK	
	EE	FI	FR	DE	EL	HU	IE	
	IT	LV	LT	LU	MT	NL	PL	
	PT	RO	SK	SI	ES	SE	UK	UK(NI)

The device is restricted to indoor use only when operating in the 5150 to 5350 MHz frequency range.

## Federal Communication Commission Interference Statement

This equipment has been tested and found to comply with the limits for a Class B digital device, pursuant to Part 15 of FCC Rules. These limits are designed to provide reasonable protection against harmful interference in a residential installation. This equipment generates, uses, and can radiate radio frequency energy and, if not installed and used in accordance with the instructions, may cause harmful interference to radio communications. However, there is no guarantee that interference will not occur in a particular installation. If this equipment does cause harmful interference to radio or television reception, which can be determined by turning the equipment off and on, the user is encouraged to try to correct the interference by one or more of the following measures:

1. Reorient or relocate the receiving antenna.
2. Increase the separation between the equipment and receiver.
3. Connect the equipment into an outlet on a circuit different from that to which the receiver is connected.
4. Consult the dealer or an experienced radio technician for help.

### FCC Caution

Any changes or modifications not expressly approved by the party responsible for compliance could void the user's authority to operate equipment.

This device complies with Part 15 of the FCC Rules. Operation is subject to the following two conditions: (1) this device may not cause harmful interference, and (2) this device must accept any interference received, including interference that may cause undesired operation.

For product available in the USA/Canada market, only channel 1~11 can be operated. Selection of other channels is not possible.

This device is restricted to indoor use.

### Federal Radiation Exposure Statement

1. This Transmitter must not be co-located or operating in conjunction with any other antenna or transmitter.
2. This equipment complies with FCC RF radiation exposure limits set forth for an uncontrolled environment. This equipment should be installed and operated with a minimum distance of 20 centimeters between the radiator and your body or nearby persons.

**This device is restricted to indoor use.**

### RED Compliance Statement

#### Compliance with 2014/53/EU Radio Equipment Directive (RED)

In accordance with Article 10.8(a) and 10.8(b) of the RED, the following table provides information on the frequency bands used and the maximum RF transmit power of the product for sale in the EU:

Frequency range (MHz)	Max. Transmit Power (dBm)
2400-2483.5	19.95
5150-5250	22.84

A simplified DoC shall be provided as follows: Article 10(9)

Hereby, Edimax Technology Co., Ltd. declares that the radio equipment type **AX1800 Dual-Band Ceiling Mount PoE AP** is in compliance with Directive 2014/53/EU

The full text of the EU declaration of conformity is available at the following internet address: <http://www.edimax.com/edimax/global/>

This equipment complies with EU radiation exposure limits set forth for an uncontrolled environment. This equipment should be installed and operated with minimum distance 20cm between the radiator & your body.

**Safety**

This equipment is designed with the utmost care for the safety of those who install and use it. However, special attention must be paid to the dangers of electric shock and static electricity when working with electrical equipment. All guidelines of this and of the computer manufacture must therefore be allowed at all times to ensure the safe use of the equipment.

**EU Countries Intended for Use**

The ETSI version of this device is intended for home and office use in Austria, Belgium, Bulgaria, Cyprus, Czech, Denmark, Estonia, Finland, France, Germany, Greece, Hungary, Ireland, Italy, Latvia, Lithuania, Luxembourg, Malta, Netherlands, Poland, Portugal, Romania, Slovakia, Slovenia, Spain, Sweden, Turkey, and United Kingdom. The ETSI version of this device is also authorized for use in EFTA member states: Iceland, Liechtenstein, Norway, and Switzerland.

**EU Countries Not Intended for Use**

None

## EU Declaration of Conformity

- English:** This equipment is in compliance with the essential requirements and other relevant provisions of Directive 2014/53/EU, 2014/35/EU.
- Français:** Cet équipement est conforme aux exigences essentielles et autres dispositions de la directive 2014/53/EU, 2014/35/EU.
- Čeština:** Toto zařízení je v souladu se základními požadavky a ostatními příslušnými ustanoveními směrnic 2014/53/EU, 2014/35/EU.
- Polski:** Urządzenie jest zgodne z ogólnymi wymaganiami oraz szczególnymi warunkami określonymi Dyrektywą UE 2014/53/EU, 2014/35/EU.
- Română:** Acest echipament este în conformitate cu cerințele esențiale și alte prevederi relevante ale Directivei 2014/53/UE, 2014/35/UE.
- Русский:** Это оборудование соответствует основным требованиям и положениям Директивы 2014/53/EU, 2014/35/EU.
- Magyar:** Ez a berendezés megfelel az alapvető követelményeknek és más vonatkozó irányelveknek (2014/53/EU, 2014/35/EU).
- Türkçe:** Bu cihaz 2014/53/EU, 2014/35/EU direktifleri zorunlu istekler ve diğer hükümlerle ile uyumludur.
- Українська:** Обладнання відповідає вимогам і умовам директиви 2014/53/EU, 2014/35/EU.
- Slovenčina:** Toto zariadenie spĺňa základné požiadavky a ďalšie príslušné ustanovenia smerníc 2014/53/EU, 2014/35/EU.
- Deutsch:** Dieses Gerät erfüllt die Voraussetzungen gemäß den Richtlinien 2014/53/EU, 2014/35/EU.
- Español:** El presente equipo cumple los requisitos esenciales de la Directiva 2014/53/EU, 2014/35/EU.
- Italiano:** Questo apparecchio è conforme ai requisiti essenziali e alle altre disposizioni applicabili della Direttiva 2014/53/EU, 2014/35/UE.
- Nederlands:** Dit apparaat voldoet aan de essentiële eisen en andere van toepassing zijnde bepalingen van richtlijn 2014/53/EU, 2014/35/EU.
- Português:** Este equipamento cumpre os requisitos essenciais da Directiva 2014/53/EU, 2014/35/EU.
- Norsk:** Dette utstyret er i samsvar med de viktigste kravene og andre relevante regler i Direktiv 2014/53/EU, 2014/35/EU.
- Svenska:** Denna utrustning är i överensstämmelse med de väsentliga kraven och övriga relevanta bestämmelser i direktiv 2014/53/EU, 2014/35/EU.
- Dansk:** Dette udstyr er i overensstemmelse med de væsentligste krav og andre relevante forordninger i direktiv 2014/53/EU, 2014/35/EU.
- suomen kieli:** Tämä laite täyttää direktiivien 2014/53/EU, 2014/35/EU. oleelliset vaatimukset ja muut asiaankuuluvat määräykset.

FOR USE IN 



---

## WEEE Directive & Product Disposal



At the end of its serviceable life, this product should not be treated as household or general waste. It should be handed over to the applicable collection point for the recycling of electrical and electronic equipment, or returned to the supplier for disposal.

## Declaration of Conformity

We, Edimax Technology Co., Ltd., declare under our sole responsibility, that the equipment described below complies with the requirements of the European Radio Equipment Directive.

**Equipment: AX1800 Dual-Band Ceiling Mount PoE AP**  
**Model No.: CAX1800**

The following European standards for essential requirements have been followed:

### Directives 2014/53/EU

Spectrum : EN 300 328 V2.1.1 (2016-11)  
EN 301 893 V2.1.1 (2017-05)

EMC : EN 301 489-1 V2.2.0 (2017-03)  
EN 301 489-17 V3.2.0 (2017-03)  
EN 55032:2015/AC:2016 Class B  
EN 61000-3-2:2014  
EN 61000-3-3:2013  
EN 55035:2017

EMF : EN 62311:2008 and EN 50665:2017

Safety (LVD) : IEC 62368-1:2014 (2<sup>nd</sup> Edition) and/or EN 62368-1:2014+A11:2017

Edimax Technology Europe B.V.  
Fijenhof 2,  
5652 AE Eindhoven,  
The Netherlands

Printed Name: David Huang  
Title: Director  
Edimax Technology Europe B.V.

a company of:  
Edimax Technology Co., Ltd.  
No. 278, Xinhua 1st Rd.,  
Neihu Dist., Taipei City,  
Taiwan



Date of Signature: Nov., 2019

Signature:

Printed Name:

Albert Chang

Title:

Director

Edimax Technology Co., Ltd.

## Notice According to GNU General Public License Version 2

This product includes software that is subject to the GNU General Public License version 2. The program is free software and distributed without any warranty of the author. We offer, valid for at least three years, to give you, for a charge no more than the costs of physically performing source distribution, a complete machine-readable copy of the corresponding source code.

Das Produkt beinhaltet Software, die den Bedingungen der GNU/GPL-Version 2 unterliegt. Das Programm ist eine sog. „Free Software“, der Autor stellt das Programm ohne irgendeine Gewährleistungen zur Verfügung. Wir bieten Ihnen für einen Zeitraum von drei Jahren an, eine vollständige maschinenlesbare Kopie des Quelltextes der Programme zur Verfügung zu stellen – zu nicht höheren Kosten als denen, die durch den physikalischen Kopiervorgang anfallen.

### GNU GENERAL PUBLIC LICENSE Version 2, June 1991

Copyright (C) 1989, 1991 Free Software Foundation, Inc. 51 Franklin Street, Fifth Floor, Boston, MA 02110-1301, USA  
Everyone is permitted to copy and distribute verbatim copies of this license document, but changing it is not allowed.

#### Preamble

The licenses for most software are designed to take away your freedom to share and change it. By contrast, the GNU General Public License is intended to guarantee your freedom to share and change free software--to make sure the software is free for all its users. This General Public License applies to most of the Free Software Foundation's software and to any other program whose authors commit to using it. (Some other Free Software Foundation software is covered by the GNU Lesser General Public License instead.) You can apply it to your programs, too.

When we speak of free software, we are referring to freedom, not price. Our General Public Licenses are designed to make sure that you have the freedom to distribute copies of free software (and charge for this service if you wish), that you receive source code or can get it if you want it, that you can change the software or use pieces of it in new free programs; and that you know you can do these things.

To protect your rights, we need to make restrictions that forbid anyone to deny you these rights or to ask you to surrender the rights. These restrictions translate to certain responsibilities for you if you distribute copies of the software, or if you modify it.

For example, if you distribute copies of such a program, whether gratis or for a fee, you must give the recipients all the rights that you have. You must make sure that they, too, receive or can get the source code. And you must show them these terms so they know their rights.

We protect your rights with two steps: (1) copyright the software, and (2) offer you this license which gives you legal permission to copy, distribute and/or modify the software.

Also, for each author's protection and ours, we want to make certain that everyone understands that there is no warranty for this free software. If the software is modified by someone else and passed on, we want its recipients to know that what they have is not the original, so that any problems introduced by others will not reflect on the original authors' reputations.

Finally, any free program is threatened constantly by software patents. We wish to avoid the danger that redistributors of a free program will individually obtain patent licenses, in effect making the program proprietary. To prevent this, we have made it clear that any patent must be licensed for everyone's free use or not licensed at all.

The precise terms and conditions for copying, distribution and modification follow.

#### TERMS AND CONDITIONS FOR COPYING, DISTRIBUTION AND MODIFICATION

0. This License applies to any program or other work which contains a notice placed by the copyright holder saying it may be distributed under the terms of this General Public License. The "Program", below, refers to any such program or work, and a "work based on the Program" means either the Program or any derivative work under copyright law: that is to say, a work containing the Program or a portion of it, either verbatim or with modifications and/or translated into another language. (Hereinafter, translation is included without limitation in the term "modification".) Each licensee is addressed as "you".

Activities other than copying, distribution and modification are not covered by this License; they are outside its scope. The act of running the Program is not restricted, and the output from the Program is covered only if its contents constitute a work based on the Program (independent of having been made by running the Program). Whether that is true depends on what the Program does.

1. You may copy and distribute verbatim copies of the Program's source code as you receive it, in any medium, provided that you conspicuously and appropriately publish on each copy an appropriate copyright notice and disclaimer of warranty; keep

intact all the notices that refer to this License and to the absence of any warranty; and give any other recipients of the Program a copy of this License along with the Program.

You may charge a fee for the physical act of transferring a copy, and you may at your option offer warranty protection in exchange for a fee.

2. You may modify your copy or copies of the Program or any portion of it, thus forming a work based on the Program, and copy and distribute such modifications or work under the terms of Section 1 above, provided that you also meet all of these conditions:

- a) You must cause the modified files to carry prominent notices stating that you changed the files and the date of any change.
- b) You must cause any work that you distribute or publish, that in whole or in part contains or is derived from the Program or any part thereof, to be licensed as a whole at no charge to all third parties under the terms of this License.
- c) If the modified program normally reads commands interactively when run, you must cause it, when started running for such interactive use in the most ordinary way, to print or display an announcement including an appropriate copyright notice and a notice that there is no warranty (or else, saying that you provide a warranty) and that users may redistribute the program under these conditions, and telling the user how to view a copy of this License. (Exception: if the Program itself is interactive but does not normally print such an announcement, your work based on the Program is not required to print an announcement.)

These requirements apply to the modified work as a whole. If identifiable sections of that work are not derived from the Program, and can be reasonably considered independent and separate works in themselves, then this License, and its terms, do not apply to those sections when you distribute them as separate works. But when you distribute the same sections as part of a whole which is a work based on the Program, the distribution of the whole must be on the terms of this License, whose permissions for other licensees extend to the entire whole, and thus to each and every part regardless of who wrote it.

Thus, it is not the intent of this section to claim rights or contest your rights to work written entirely by you; rather, the intent is to exercise the right to control the distribution of derivative or collective works based on the Program.

In addition, mere aggregation of another work not based on the Program with the Program (or with a work based on the Program) on a volume of a storage or distribution medium does not bring the other work under the scope of this License.

3. You may copy and distribute the Program (or a work based on it, under Section 2) in object code or executable form under the terms of Sections 1 and 2 above provided that you also do one of the following:

- a) Accompany it with the complete corresponding machine-readable source code, which must be distributed under the terms of Sections 1 and 2 above on a medium customarily used for software interchange; or,
- b) Accompany it with a written offer, valid for at least three years, to give any third party, for a charge no more than your cost of physically performing source distribution, a complete machine-readable copy of the corresponding source code, to be distributed under the terms of Sections 1 and 2 above on a medium customarily used for software interchange; or,
- c) Accompany it with the information you received as to the offer to distribute corresponding source code. (This alternative is allowed only for noncommercial distribution and only if you received the program in object code or executable form with such an offer, in accord with Subsection b above.)

The source code for a work means the preferred form of the work for making modifications to it. For an executable work, complete source code means all the source code for all modules it contains, plus any associated interface definition files, plus the scripts used to control compilation and installation of the executable. However, as a special exception, the source code distributed need not include anything that is normally distributed (in either source or binary form) with the major components (compiler, kernel, and so on) of the operating system on which the executable runs, unless that component itself accompanies the executable.

If distribution of executable or object code is made by offering access to copy from a designated place, then offering equivalent access to copy the source code from the same place counts as distribution of the source code, even though third parties are not compelled to copy the source along with the object code.

4. You may not copy, modify, sublicense, or distribute the Program except as expressly provided under this License. Any attempt otherwise to copy, modify, sublicense or distribute the Program is void, and will automatically terminate your rights under this License. However, parties who have received copies, or rights, from you under this License will not have their licenses terminated so long as such parties remain in full compliance.

5. You are not required to accept this License, since you have not signed it. However, nothing else grants you permission to modify or distribute the Program or its derivative works. These actions are prohibited by law if you do not accept this License.

Therefore, by modifying or distributing the Program (or any work based on the Program), you indicate your acceptance of this License to do so, and all its terms and conditions for copying, distributing or modifying the Program or works based on it.

6. Each time you redistribute the Program (or any work based on the Program), the recipient automatically receives a license from the original licensor to copy, distribute or modify the Program subject to these terms and conditions. You may not impose any further restrictions on the recipients' exercise of the rights granted herein. You are not responsible for enforcing compliance by third parties to this License.

7. If, as a consequence of a court judgment or allegation of patent infringement or for any other reason (not limited to patent issues), conditions are imposed on you (whether by court order, agreement or otherwise) that contradict the conditions of this License, they do not excuse you from the conditions of this License. If you cannot distribute so as to satisfy simultaneously your obligations under this License and any other pertinent obligations, then as a consequence you may not distribute the Program at all. For example, if a patent license would not permit royalty-free redistribution of the Program by all those who receive copies directly or indirectly through you, then the only way you could satisfy both it and this License would be to refrain entirely from distribution of the Program.

If any portion of this section is held invalid or unenforceable under any particular circumstance, the balance of the section is intended to apply and the section as a whole is intended to apply in other circumstances.

It is not the purpose of this section to induce you to infringe any patents or other property right claims or to contest validity of any such claims; this section has the sole purpose of protecting the integrity of the free software distribution system, which is implemented by public license practices. Many people have made generous contributions to the wide range of software distributed through that system in reliance on consistent application of that system; it is up to the author/donor to decide if he or she is willing to distribute software through any other system and a licensee cannot impose that choice.

This section is intended to make thoroughly clear what is believed to be a consequence of the rest of this License.

8. If the distribution and/or use of the Program is restricted in certain countries either by patents or by copyrighted interfaces, the original copyright holder who places the Program under this License may add an explicit geographical distribution limitation excluding those countries, so that distribution is permitted only in or among countries not thus excluded. In such case, this License incorporates the limitation as if written in the body of this License.

9. The Free Software Foundation may publish revised and/or new versions of the General Public License from time to time. Such new versions will be similar in spirit to the present version, but may differ in detail to address new problems or concerns.

Each version is given a distinguishing version number. If the Program specifies a version number of this License which applies to it and "any later version", you have the option of following the terms and conditions either of that version or of any later version published by the Free Software Foundation. If the Program does not specify a version number of this License, you may choose any version ever published by the Free Software Foundation.

10. If you wish to incorporate parts of the Program into other free programs whose distribution conditions are different, write to the author to ask for permission. For software which is copyrighted by the Free Software Foundation, write to the Free Software Foundation; we sometimes make exceptions for this. Our decision will be guided by the two goals of preserving the free status of all derivatives of our free software and of promoting the sharing and reuse of software generally.

#### **NO WARRANTY**

11. BECAUSE THE PROGRAM IS LICENSED FREE OF CHARGE, THERE IS NO WARRANTY FOR THE PROGRAM, TO THE EXTENT PERMITTED BY APPLICABLE LAW. EXCEPT WHEN OTHERWISE STATED IN WRITING THE COPYRIGHT HOLDERS AND/OR OTHER PARTIES PROVIDE THE PROGRAM "AS IS" WITHOUT WARRANTY OF ANY KIND, EITHER EXPRESSED OR IMPLIED, INCLUDING, BUT NOT LIMITED TO, THE IMPLIED WARRANTIES OF MERCHANTABILITY AND FITNESS FOR A PARTICULAR PURPOSE. THE ENTIRE RISK AS TO THE QUALITY AND PERFORMANCE OF THE PROGRAM IS WITH YOU. SHOULD THE PROGRAM PROVE DEFECTIVE, YOU ASSUME THE COST OF ALL NECESSARY SERVICING, REPAIR OR CORRECTION.

12. IN NO EVENT UNLESS REQUIRED BY APPLICABLE LAW OR AGREED TO IN WRITING WILL ANY COPYRIGHT HOLDER, OR ANY OTHER PARTY WHO MAY MODIFY AND/OR REDISTRIBUTE THE PROGRAM AS PERMITTED ABOVE, BE LIABLE TO YOU FOR DAMAGES, INCLUDING ANY GENERAL, SPECIAL, INCIDENTAL OR CONSEQUENTIAL DAMAGES ARISING OUT OF THE USE OR INABILITY TO USE THE PROGRAM (INCLUDING BUT NOT LIMITED TO LOSS OF DATA OR DATA BEING RENDERED INACCURATE OR LOSSES SUSTAINED BY YOU OR THIRD PARTIES OR A FAILURE OF THE PROGRAM TO OPERATE WITH ANY OTHER PROGRAMS), EVEN IF SUCH HOLDER OR OTHER PARTY HAS BEEN ADVISED OF THE POSSIBILITY OF SUCH DAMAGES