

Euro Pen Kits Assembly Instructions

Required Accessories:

- 7mm long mandrel
- 7mm drill bit BPD-7MM-PRC
- 3 pcs. pen bushings BUSH-BT-N
- 7mm barrel trimmer CT-PM-7MM or CT-PM-SET-4E
- 2 part epoxy glue (cyanoacrylate)



Diagram A/Parts Layout



Preparing the Blanks:

- Cut 16mm square blanks, to the length of the brass tubes (add 1.6mm for squaring off).
- Drill a 7mm centered hole lengthwise through each blank.
- Spread glue over the tubes. Insert the tubes into the blanks with a twisting motion to spread the glue evenly inside. Center the tubes lengthwise inside the blanks.
- When the glue dries, square the ends of the blanks. Use a 7mm barrel trimmer or belt/disc sander to take the wood down flush to the brass tube.

Diagram B / Turning the Blanks

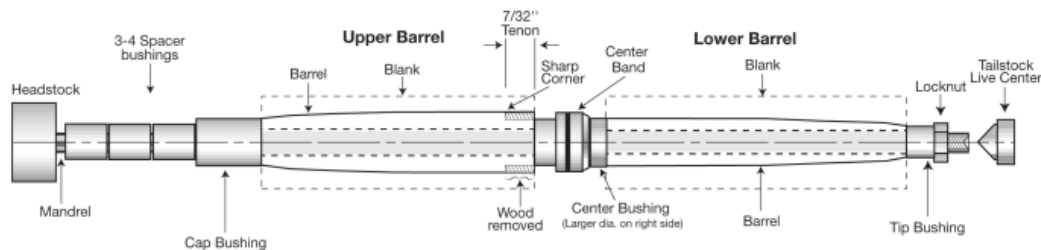

Turning the Blanks:

- Place 3-4 spacer bushings onto the mandrel. Place the cap bushing next on the mandrel, then slide on the upper blank. Place the center band or a scrap band over the center bushing, square end of band toward cap. Place this on mandrel. Use tape to hold the center band against the lower blank. Place lower blank against the center bushing, next, slide on the tip bushing, thread

the lock nut hand tight. Bring the tailstock snug with the mandrel. (Do not over tighten, it could damage the mandrel). Slide the stop bushing towards the blank, adjusting to remove spaces, then tighten the screw set and lock nut.

- Turn the wood down to the bushings and the diameter of the center band with chisels and sand paper. Taper the end cap and tip ends of the blanks (follow diagram C for profile) to conform with the cap and tip. Remove tape and use the outside dia. of the band to determine the outside diameter of the upper blank. Be sure the wood on the lower blank next to center bushing does not exceed the bushing diameter, it may cause the twisting mechanism to jam when parts are engaged. Sand down to the final size.

Cutting the Tenon:

- Keep the center band away from the upper barrel. Make a pencil mark 6mm from end. Use a parting tool to cut a 6mm tenon down to the diameter of the bushing.

Use the center band by sliding it over tenon to achieve a good snug fit. Make sure you keep a sharp outside 90° corner on the tenon. Finish, polish and wax both barrels.

- Use a finish of your choice but be careful if brushing on a poly, etc. You can stick the tube, bushings, and mandrel together.

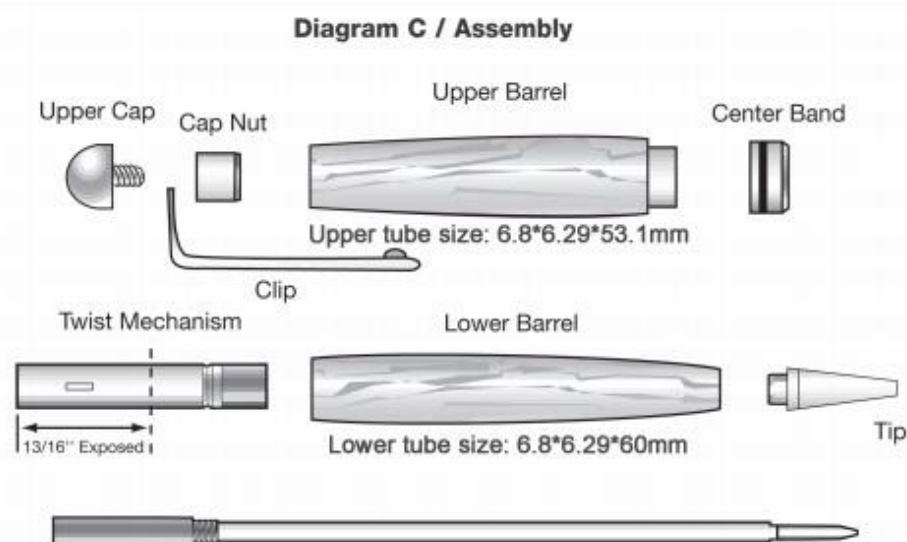

Assembly

- Line up finished parts according to diagram C.
- To press parts together, use a pen press or a vice or a clamping instrument with wooden jaws. Press with caution, to avoid cracking the wood or scratching gold plated parts.
- Press the cap nut (recessed end first) into the tapered end of the upper barrel (shorter).
- Use a drop of glue around the tenon, slide center band (square end first) over the tenon. Push in, let dry.
- Insert the cap thread into the hole in the clip. Screw together tightly into cap nut.
- Press tip into the tapered end of the lower barrel (longer).
- Scribe a line/ mark on the twist mechanism 21mm from the chrome end. Press with the brass end of the mechanism first into the opposite end of the barrel to the line scribed. Leaving 21mm exposed.
- Twist the mechanism and pen barrel to check the retracting and extension of the refill. Press the mechanism further in if necessary.
- Insert refill into twist mechanism and screw to the end.
- Engage and push barrels together.
- Pen operates by twisting the barrels to extend or retract writing tip.