

CORE BOX BITS

For use in fluting flat surfaces such as mantles and facades.

TWO FLUTE
 SUFFIX 1/2 = 1/2"
 SHANK, OTHERWISE 1/4"

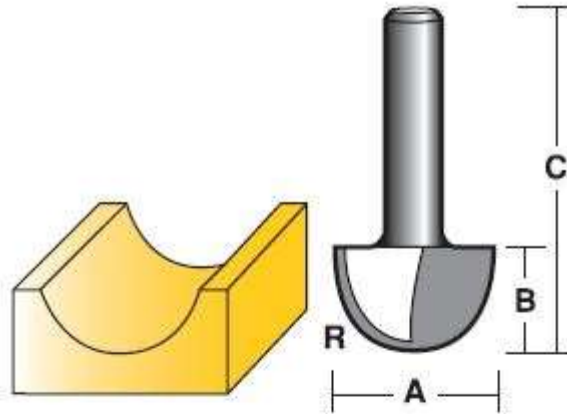

PART No.	A		B		C		R RADIUS	
	in.	mm	in.	mm	in.	mm	in.	mm

HIGH SPEED STEEL

H 408	1/4	6.35	1/4	6.35	1-1/4	31.8	1/8	3.2
H 412	3/8	9.5	1/4	6.35	1-1/4	31.8	3/16	4.8
H 416	1/2	12.7	11/32	8.7	1-1/4	31.8	1/4	6.35
H 420	5/8	15.9	3/8	9.5	1-3/8	35	5/16	8.0
H 424	3/4	19	15/32	12	1-3/8	35	3/8	9.5

SOLID CARBIDE

T 408	1/4	6.35	5/16	8	1-1/2	38.1	1/8	3.2
-------	-----	------	------	---	-------	------	-----	-----

CARBIDE TIPPED

T 410	5/16	7.9	1/4	6.35	1-1/4	31.8	5/32	4.0
T 412	3/8	9.5	1/4	6.35	1-1/4	31.8	3/16	4.8
T 416	1/2	12.7	31/64	12.2	1-1/2	38.1	1/4	6.35
T 416 1/2	1/2	12.7	31/64	12.2	2-1/4	57.1	1/4	6.35
T 420	5/8	15.9	3/8	9.5	1-3/4	44.4	5/16	8.0
T 420 1/2	5/8	15.9	3/8	9.5	2-1/4	57.1	5/16	8.0
T 424	3/4	19	1/2	12.7	1-7/8	47	3/8	9.5
T 424 1/2	3/4	19	1/2	12.7	2-1/4	57.1	3/8	9.5
T 432 1/2	1	25.4	5/8	15.9	2-1/2	63.5	1/2	12.7
T 440 1/2	1-1/4	31.8	3/4	19	2-1/2	63.5	5/8	15.9
T 448 1/2	1-1/2	38	7/8	22.2	2-5/8	67	3/4	19.0