

# DOVETAIL BITS

For dovetail joint, drawer fronts, etc. for the quality minded craftsman.

TWO FLUTE  
 SUFFIX 1/2 = 1/2" SHANK,  
 SUFFIX 3/8 = 3/8" SHANK,  
 SUFFIX 10mm = 10mm  
 SHANK, OTHERWISE 1/4"

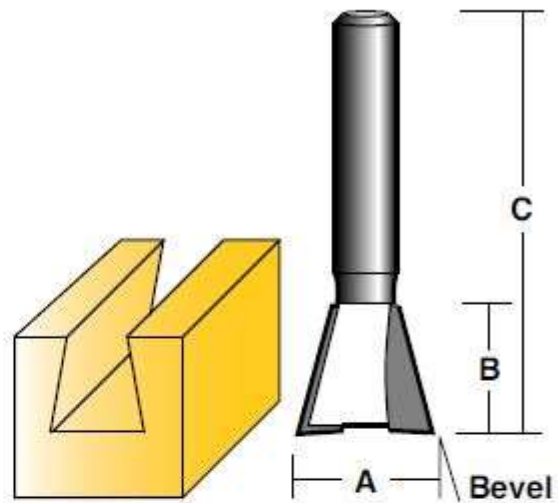

PART No.	A		B	C		Bevel
	in.	mm	mm	in.	mm	

## HIGH SPEED STEEL

H 1012	9/32	7.1	9.5	1-5/8	41	5°
H 1018	9/16	14.3	13.5	1-5/8	41	15°
H 1018 1/2	9/16	14.3	13.5	2	50.8	15°

## SOLID CARBIDE

T 1012	9/32	7.1	9.5	1-1/2	38.1	5°
--------	------	-----	-----	-------	------	----

## CARBIDE TIPPED

T 1016	1/2	12.7	13.5	1-3/4	44.4	15°
T 1018	9/16	14.3	13.5	1-3/4	44.4	15°
T 1018 3/8	9/16	14.3	13.5	2-3/4	70	15°
T 1018 10MM	9/16	14.3	13.5	2-3/4	70	15°
T 1018 1/2	9/16	14.3	13.5	2-3/4	70	15°
T 1019	19/32	15	12.7	1-3/4	44.4	15°
T 1024 1/2	3/4	19	26	2-3/4	70	5°