

2 & 3-Compartment Clear RPET Takeaway Lid B-LBL-2/3C-RPET

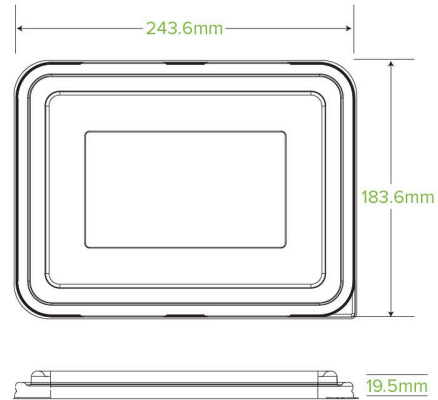

Our PET clear lids are great for packaging cold food. They are not compatible with hot foods, microwave or oven heating. This is the matching lid for the 2 & 3 compartment trays. Recyclable in most councils.

Carton quantity: 500	Sleeves per carton: 4	Units per sleeve: 125
Carton Size LxWxH (cm): 50x45x39	Carton gross weight (kg): 10.750000	Carton barcode: 19344062061523
Raw material: Plastic - Recycled PET (Polyethylene Terephthalate)	Lining/coating: None	Window material: None
Printing Type: None	Inks: None	Dimensions top LxW (mm): 243x183
Dimensions base LxW (mm): 243x183	Product Depth: 19	Product weight (g): 21.5
Use: Cold, Wet & Dry Products	Manufactured: China	Customise: Yes - Please Contact Our Team For More Information
MOQ custom: MOQ apply see custom packaging	Mould fees: Yes - see custom packaging	Environmental production certified: ISO 14001
Facility Quality Systems: ISO 9001	Factory food safety certified: BRC	Corporate social accreditation: BSCI
Home compostable: No	Industrially compostable: No	Recyclable: Yes