

460ml / 16oz (90mm) Kraft Green Stripe Double Wall BioCup BCK-16DW-GS-V2

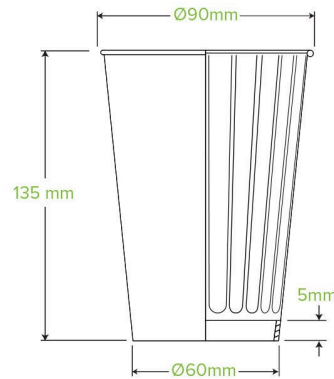

Paper Double Wall BioCups are lined with a water-based aqueous coating and certified home compostable (AS5810). This 16oz Green Stripe BioCup is printed kraft-look. This takeaway cup fits our large lids

Carton quantity: 600	Sleeves per carton: 15	Units per sleeve: 40
Carton Size LxWxH (cm): 45.5x27.5x64	Carton gross weight (kg): 12.860000	Raw material: Paper - FSC™ Mix certified paper
Lining/coating: Aqueous	Window material: None	Printing Type: Offset
Inks: Food Contact Safe Inks	Brim fill capacity (ml): 464	Dimensions top LxW (mm): 90x90
Dimensions base LxW (mm): 60x60	Product Depth: 136	Product weight (g): 20
Thickness: 285gsm + 35gsm	Use: Hot, Cold, Wet & Dry Products	Manufactured: China
Customise: Print	MOQ custom: 50000	Mould fees: No
Environmental production certified: ISO 14001	Facility Quality Systems: No	Factory food safety certified: BRC
Corporate social accreditation: SMETA	Home compostable: Certified to AS5810 Australian standards, Certified to NF T51-800 European standards	Industrially compostable: Certified to EN13432 European Standards
Recyclable: No		