

Unlined Large Enclosed BioBoard Chip Box BB-CHIP-L

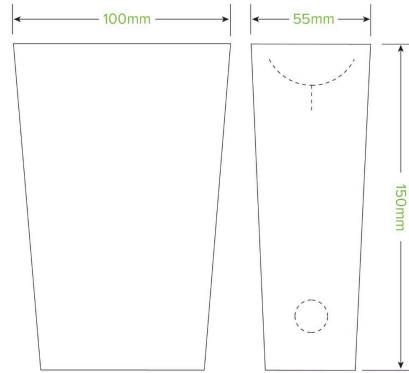

Our Enclosed Chip Boxes are made from premium paperboard and have a self-closing lid that protects chips during transit. This functional, secure design allows for efficient takeaway that avoids any spillage in takeaway bags. The ventilation holes prevent the chips from going soggy. Home compostable and recyclable if clean. Available in small & large.

Carton quantity: 800	Sleeves per carton: 8	Units per sleeve: 100
Carton Size LxWxH (cm): 66x19x36	Carton gross weight (kg): 12.700000	Carton barcode: 19344062072345
Raw material: Paper - FSC™ Recycled	Lining/coating: None	Window material: None
Printing Type: Offset	Inks: Food Contact Safe Inks	Brim fill capacity (ml): 628
Dimensions top LxW (mm): 100x55	Dimensions base LxW (mm): 75x40	Product Depth: 150
Product weight (g): 14.86	Thickness: 260gsm	Use: Dry Contents Only, Hot or Cold
Manufactured: China	Customise: Print	MOQ custom: 30000
Mould fees: No	Environmental production certified: ISO 14001	Facility Quality Systems: ISO 9001
Factory food safety certified: BRC	Corporate social accreditation: SMETA	Home compostable: No
Industrially compostable: No	Recyclable: Yes - If Not Contaminated By Food	