

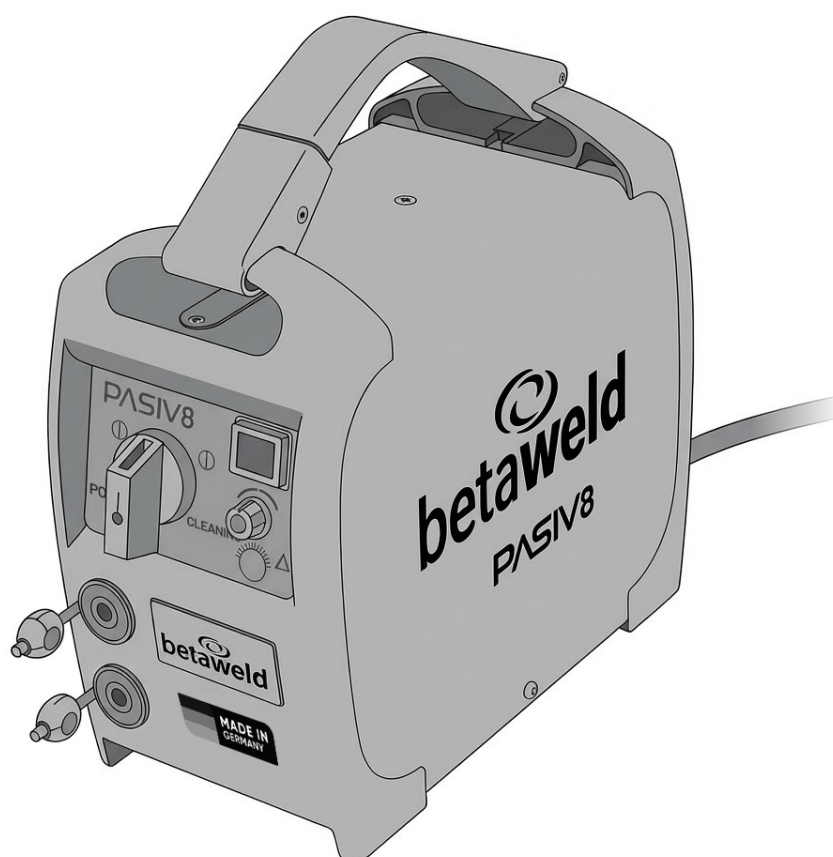

OPERATING INSTRUCTIONS



PASIV8

ELECTROCHEMICAL CLEANING AND POLISHING EQUIPMENT

VERSION
V1 | 24.10.2025
V2 | 10.02.2026

BETAWELD
PO Box 1498 Canning Vale DC 6970
AUSTRALIA
Phone: 1300 120 130
info@betaweld.com.au



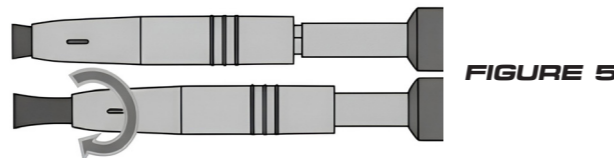
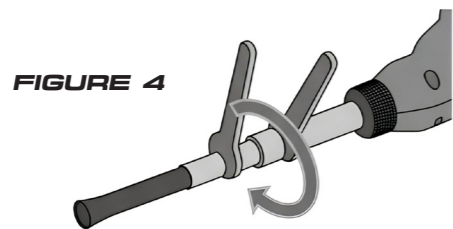
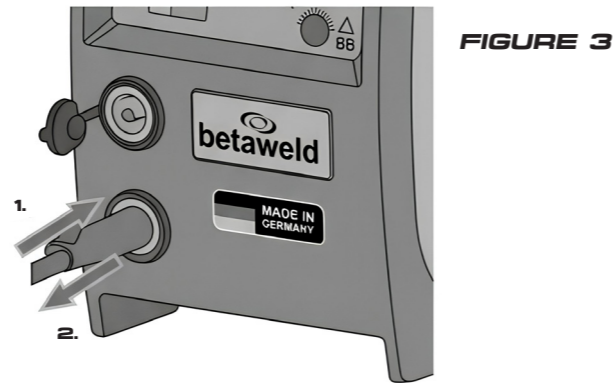
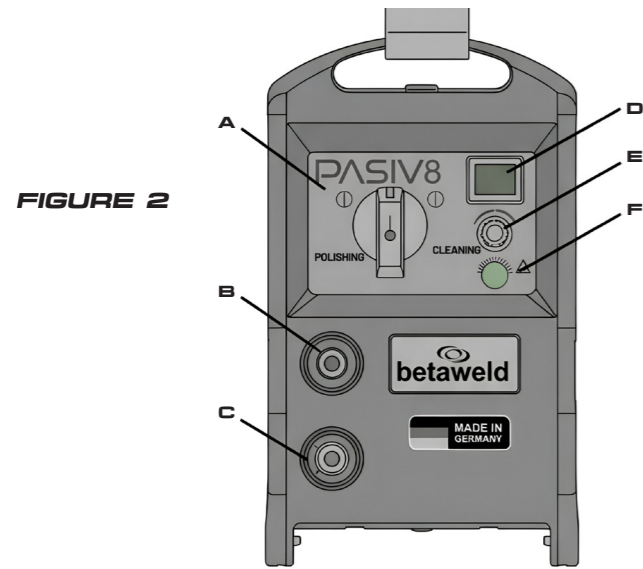
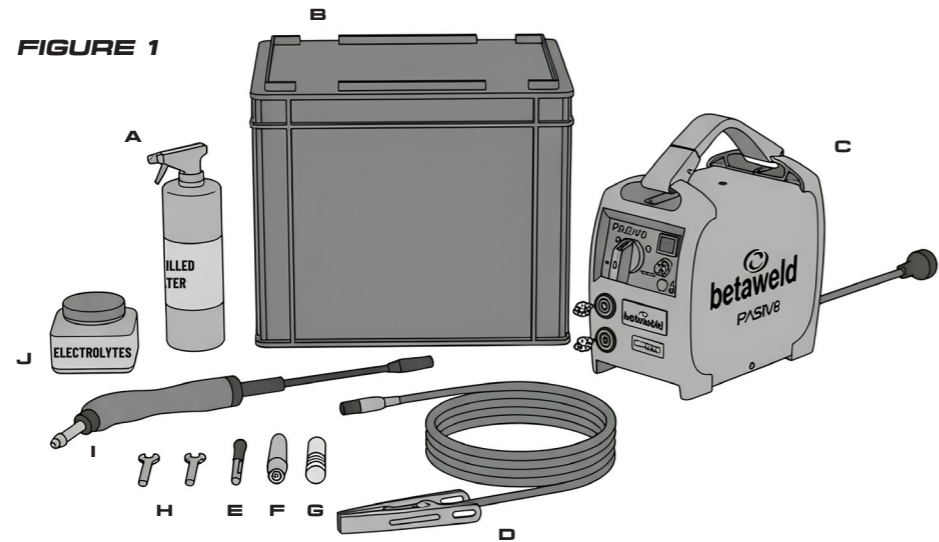

1. Scope of delivery

A	6153	Distilled water spray bottle 500ml	G	6158	Screw sleeve XL
B	AB-07-001	Shipping/storage box	H	6157	Open Spanner SW 10mm (2pc)
C	6050	PASIV8 (see specification plate)	I	6155	Betaweld handle, 4m, 10mm ²
D	6156	Ground clamp, 4m, 10mm ²	J	6154	Wide mouth container, 500ml
E	6150	Performance brush XL (1/5 pcs.)			
F	EP-02-816	Brush protective cap			

2. Front controls

A	Function switch	D	Power switch with indicator light
B	Black high-current socket with plug (for brush)	E	Thermal fuse
C	Red high-current socket with plug (for ground clamp)	F	Indicator light (output power)

1 Identification	3 5 Operation	6
1.1 Labeling	3 5.1 Adjusting the length of the carbon fibre brush	7
1.2 Classification of warnings	3 5.2 Preparing the required liquids	7
	5.3 Cleaning the weld seam	7
2 Safety	4 5.4 Polishing the weld seam	7
2.1 Intended use	4 5.5 Finishing the cleaning and polishing process	7
2.2 Safety instructions for electrical engineering		
2.3 Product-specific safety instructions	6 Decommissioning	7
2.4 Safety instructions for cleaning and polishing	4 6.1 Disconnecting the high-current connector	8
2.5 Chemical substance safety instructions		
2.6 Safety instructions for use	7 Maintenance and cleaning	8
2.7 Safety instructions for protective clothing	5 7.1 Maintenance and cleaning intervals	8
2.8 Information for emergencies	5 7.2 Replacing the carbon fibre brush	8
3 Product	5 8 Faults and troubleshooting	8
3.1 Technical data	5 8.1 Thermal fuse has blown	8
3.2 Thermal protection	5 8.2 Insufficient power	8
3.3 Cleaning/polishing handle	5 8.3 Poor cleaning effect	8
3.4 Ground clamp	5 8.4 High material wear	9
4 Commissioning	5 9 Disposal and further information	9
4.1 Mounting carbon fibre brushes	5 9.1 Disposing of electrolytes	9
4.2 Connecting the ground clamp	5 9.2 Process vapors	9
	5 9.3 Passivation of stainless steel	9
	10 Warranty	9

1. Identification
Electrochemical cleaning and polishing devices are used to clean and polish stainless steels. This operating manual refers to the Betaweld PASIV8 devices. They are designed for commercial use in workshops and industry.

The respective device may only be operated with original spare parts and accessories from Betaweld. The illustrations in this instruction show the cleaning device in the PASIV8 version.

1.1 Labeling
The product fulfils the requirements that apply to the market to which it has been introduced.

If corresponding labeling is required, it has been attached to the product.

1.2 Classification of warnings
The warnings used in this operation manual are divided into four different levels of potentially dangerous working steps.

Depending on the type of danger, the following signals are used:

! DANGER

Describes an imminent danger. If not avoided it may cause severe injury or death.

! WARNING

Describes a potentially dangerous situation. If not avoided it may cause severe injury or death.

! CAUTION

Describes a potentially harmful situation. If not avoided minor or slight injuries may result.

! NOTICE

Describes the risk of impairing work results or potential material damage and irreparable damage to the device or the equipment.

2. Safety

The product has been developed and manufactured in accordance with state-of-the-art technology and the recognised safety standards and regulations. These operating instructions provide you with all the information you need for trouble-free and safe operation. These operating instructions provides you with basic safety instructions and warns you against residual hazards which must be observed in order to operate the product safely. Non-observance of the safety instructions may result in risks to the life or health of personnel and result in environmental damage or material damage. The manufacturer will accept no liability for damage caused by non-observance of the documentation.

- Please read the documentation carefully before using the product for the first time and comply with the instructions provided.
- Only operate the product in technically perfect condition in compliance with all documentation.
- Provide good lighting of the work area and keep the work area clean.

- For the entire duration of maintenance, servicing and repair work, switch off the power source and disconnect the mains plug.
- Thoroughly read the documentation before carrying out any specific work, e.g. commissioning, operation, transport and maintenance.
- Protect yourself and others from the hazards described in the documentation.
- Store the documentation within easy reach of the device for reference and enclose all documentation when transferring the product.
- Observe all local accident prevention regulations.
- Have commissioning as well as operating and maintenance work carried out exclusively by qualified personnel. Qualified personnel are persons who, based on their special training, knowledge, experience and due to their knowledge of the relevant standards, are able to assess the tasks assigned to them and identify possible dangers.
- For disposal observe all local regulations, laws, provisions, standards and guidelines.

2.1 Intended use

- The device described in this manual may only be used for the purpose described in the instructions and in the manner described. Observe the operating, maintenance and servicing conditions.
- The device is designed exclusively for commercial use.

- Any other use is considered improper use.
- Unauthorised modifications or changes to increase performance are not permitted.

2.2 Electro-technical safety instructions

- Check the respective device for any damage and correct functionality as intended in this manual.
- Do not expose the device to rain and avoid a moist or wet environment.

- Protect yourself from electric shock by using insulating pads and wearing dry clothing.
- Do not use the device in areas with a risk of fire or explosion.

2.3 Product-specific safety instructions

! WARNING

Dangers due to improper use

If the device is not used as intended, it may cause a risk to people, animals and property.

- Only use the device as intended.
- Do not use the device in rain or snow.
- Do not use the device where there is an increased risk of electric shock.
- The device must not be used to defrost pipes.
- Only place the device on dry, leveled surfaces to prevent it from tipping over.
- Do not modify the device to increase its performance.
- Ensure that any work on the device or system is only carried out by qualified persons.
- Do not short-circuit the carbon fibre brush and the ground clamp. There is a risk of skin burns.
- Do not touch uninsulated components of the handle and the earthing pliers at the same time. There is a risk of electric shock.
- Please note that specific workplace safety standards may apply. Inform yourself in advance.

! CAUTION

Risk of injury and damage to the device by unauthorised persons

Improper repairs and modifications to the product may lead to serious injuries and damage to the device. The product warranty is invalidated if tampered with by unauthorised persons.

- Ensure that any work on the device or system is only carried out by authorised and qualified persons.

2.4 Safety instructions for cleaning and polishing

- Electromagnetic fields can affect pacemakers. Persons with pacemakers are not allowed to work with the device and are not allowed to stay in the immediate vicinity of the device.
- Carbon fibre brushes or electrodes and workpieces can become very hot. There is a risk of burns. Wear protective gloves.

2.5 Safety instructions on chemical substances

- Only use electrolytes from Betaweld
- Observe the safety data sheet of the electrolyte used.
- Electrolyte splashes can cause burns to the eyes and skin. Always wear the prescribed, acid-resistant protective clothing in accordance with the relevant local regulations.
- Use the device only in well-ventilated areas to avoid inhaling vapors.

2.6 Safety instructions for use

- Do not exceed the maximum load data specified in the documentation. Overloads may lead to destruction.
- Do not make any structural changes to the product.
- Do not use the device outdoors, in wet conditions and in environments where there is a risk of fire and explosion.

2.7 Safety instructions for protective clothing

- Do not wear loose clothing or jewellery.
- Wear a hairnet if you have long hair.

2.8 Information for emergencies

In case of emergency immediately cut off the electrical power supply.

3. Product

When cleaning with the carbon fibre brush, contamination caused by welding is removed from the surface and the passive layer of the stainless steel is renewed. When polishing with the carbon fibre brush,

- All metal vapors are harmful! Ensure adequate ventilation or extraction. Do not exceed the applicable occupational exposure limits (OEL).
- Do not place the brush on the workpiece. Otherwise an electric current may flow.

- Electrolyte splashes can cause chemical burns on stone floors or other materials. Wipe up electrolyte splashes immediately with plenty of water.
- Store and dispose of electrolytes in accordance with safety data sheets (SDS) and local regulations. Keep the electrolyte away from children and pets.
- If electrolyte gets into the eyes, rinse them immediately with plenty of water and consult an ophthalmologist immediately.







Protect the device from the effects of acids and alkalis. Do not expose the device to ionising or non-ionising radiation, vibration, shock, or continuous shock.

- Wear acid-resistant goggles, protective gloves and an acid-resistant apron.

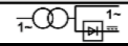
in addition to cleaning, material in the Qm range is removed, thus creating a polished surface. The device works with low alternating or direct voltage (AC/DC), which is harmless to humans.

3.1 Technical data

PASIV8 (230V)	
Permissible temperature for storage and transport	-20 °C to +55 °C
Permissible ambient temperature	-10°C to +40°C
Weight	6.2 kg
Dimensions (L x W x H)	300mm x 150mm x 240mm
Total weight with accessories	Protection class I
EMC classification	Class A
Supply voltage	U1 = 230V
Plug Type	AU Plug Type I 15A

Betaweld PO Box 1498 Canning Vale DC 6970 AUSTRALIA P: 1300 120 130 W: betaweld.com.au		 creating better welding solutions Made in Germany	
Type	PASIV8	S.-Nr.:	
		DIN EN IEC 60974-1 DIN EN IEC 60974-10	
CLEANING AC	50Hz/60Hz	0A/9,5VAC - 80A/8,2VAC	
	U ₀ = 9,5VAC	X [40°C]	30% 60% 100%
		I ₂	80A 70A 60A
		U ₂	8,2 VAC 8,4 VAC 8,6 VAC
POLISHING DC		0A/15,8VDC - 40A/9,2VDC	
	U ₀ = 15,8VDC	X [40°C]	30% 60% 100%
		I ₂	40A 30A 26A
		U ₂	9,2 VDC 10,0 VDC 10,5 VDC
	1~ 50/60Hz	U ₁ = 230V	I _{max} = 11,7A I _{eff} = 3,6A
IP21		AF	  

3.2 Thermal protection

- The device has several thermal protection units.
- All thermal devices, except for the thermal fuse on the front of the device, is self-resetting.

- The thermal fuse on the front is designed for a short-circuit current of over 80A.
- See chapter 8.1

3.3 Cleaning/polishing handle

- The tool set includes a handle for manual electrochemical work with a carbon fibre brush.
- Only connect the handle to approved power sources from Betaweld.
- Use the carbon fibre brush handle only as intended for electrochemical work with a device from Betaweld.
- Only use original carbon fibre brushes with a suitable M10 thread from Betaweld.
- Connect the plug of the handle to the black socket on the device, as described in chapter 4.1.
- The handle complies with the requirements of EN IEC 60974-7: 2020-06

Part number	6155
Permissible temperature for storage and transport	-20°C to +55°C
Permissible ambient temperature	-10°C to +40°C
Cable cross-section	10mm ²
Cable length	4m
Weight	0.7kg
Brush sizes	XL-Performance
Duty cycle at 40°C	100%/60A; 60%/70A; 30%/80A

WARNING

Risk of burns due to hot components

- The handle becomes hot in the front area.
- Only touch the handle in the area of the red grip shells during operation.

3.4 Ground clamp

- Attach/clamp the ground clamp directly to the workpiece
- Connect the plug of the ground clamp to the red socket on the device, as described in chapter 4.1.
- Only connect the ground clamp to approved power sources from Betaweld.
- The ground clamp complies with the requirements of EN IEC 60974-13:2022-03

Part number	6156
Permissible temperature for storage and transport	-20°C to +55°C
Permissible ambient temperature	-10°C to +40°C
Cable cross-section	10mm ²
Cable length	4m
Weight	0.9kg
Duty cycle at 40°C	100%/80A

WARNING

Risk of burns due to hot components

- The ground clamp becomes hot in the area of current transmission.
- Only touch the ground clamp in the rear area during operation.

4. Commissioning

Carry out all the action steps in the specified order.

4.1 Mounting the carbon fibre brush

1. Remove the brush tube and screw sleeve.
2. Attach the carbon fibre brush with two open-end wrenches. Counter the adapter to avoid damaging the handle.
3. Reassemble the screw sleeve and adjust the brush correctly, see 5.1.

4. Pull the elastic socket cover out of the socket.
5. Insert the high-current plug of the carbon fibre brush into the black high-current socket of the device [B] until it clicks.

4.2 Connecting the ground clamp

1. Attach the ground clamp to the workpiece. Ensure good contact and a tight fit. If necessary, clean the contact area beforehand.

2. Pull the socket cover out of the socket.
3. Insert the high-current plug of the ground clamp into the red high-current socket of the device [C] until it clicks.

5. Operation

To operate, you will also need distilled or demineralised water and clean paper towels.

5.1 Adjusting the length of the carbon fibre brush

1. Turn the screw sleeve until approx. 15mm of the carbon fibre tips protrude from the screw sleeve.
2. The carbon fibre tips wear out during operation. Therefore, adjust the screw sleeve regularly.

3. Replace the brush if the screw sleeve can no longer be turned backwards.

5.2 Prepare the fluids you need

1. Fill the wide-neck container with approx. 15-25mm of electrolyte from the storage bottle.

2. Pour distilled or demineralised water into the spray bottle.

5.3 Cleaning the weld seam

1. Insert the power plug and switch on the device with the power switch.
2. Set the function switch to <cleaning>. The green indicator light is on.
3. Dip the carbon fibre brush briefly into the electrolyte and drain off any excess electrolyte.
4. Place the carbon fibre brush vertically on the weld seam. Glide over the workpiece several times with light pressure and circular movements until the weld seam is completely cleaned.

5. Dip the carbon fibre brush into the electrolyte at regular intervals, move it back and forth two to three times, squeezing the fibres at the bottom of the wide-mouth container. This removes dissolved oxides and other contaminants from the brush and cools the electrode.
6. Rinse the cleaned surface immediately with distilled water from the spray bottle.
7. Dry the workpiece with clean paper towels.

WARNING

Risk of burns due to hot surface

- The workpiece is heated strongly during the cleaning process.
- Do not touch the surface. Wear appropriate protective gloves.
 - Cool the workpiece by rinsing water.

5.4 Polishing the weld seam

1. Plug in the power plug and turn on the appliance with the power switch.
2. Set the function switch to <polishing>. The green indicator light is on.
3. Dip the carbon fibre brush briefly into the electrolyte and drain off any excess electrolyte.
4. Place the carbon fibre brush vertically on the surface to be polished. Glide over the workpiece several times with light pressure and circular movements until the surface reaches the desired shine.
5. The polishing process takes longer than the cleaning process. Therefore, the workpiece must be rinsed with water in between to avoid overheating.

6. Dip the carbon fibre brush into the electrolyte at regular intervals, move it back and forth two to three times, squeeze the fibres at the bottom of the wide-mouth container. This removes dissolved oxides and other contaminants from the brush and cools the electrode.
7. Rinse polished surface immediately with distilled water from the spray bottle.
8. Dry the workpiece with clean paper towels.

WARNING

Risk of burns due to hot surface

- The workpiece is heated strongly during the cleaning process.
- Do not touch the surface. Wear appropriate protective gloves.
 - Cool the workpiece by rinsing.

5.5 Completing the cleaning and polishing process

1. Carefully wipe off excess electrolyte on the carbon fibre brush at the edge of the wide-neck container and close the wide-neck container.

2. Put the protective cap over the carbon fibre brush.
3. Remove the ground clamp from the workpiece and rinse with water.

6. Decommissioning

1. Switch off the device at the main switch.
2. Disconnect the high-current plug.
→ See Chapter 6.1: Disconnecting the high-current plug
3. Wipe the cable and case with a cloth.
4. Insert the cover plugs into the sockets of the device.
5. Clean the device.
6. Wipe off the carbon fibre brush with a cloth and put the protective cap over it.

7. Dispose the paper towels in the residual waste.
8. Collect wastewater and dispose it properly.
9. Carefully close the electrolyte container.
10. Store the device and accessories in the transport box and secure it from unintentional opening (e.g. with cable ties).
11. Store the device in the transport box in a dry and frost-free place.

6.1 Disconnecting the high-current plug

The high-current plugs lock automatically when plugged into the corresponding socket and can only be unlocked by pressing them in again. Never pull the high-current plug out of the socket by the cable.

- Press the high-current plug into the high-current socket up to a resistance (light click). The lock is released.
- Pull the high-current plug out of the socket.

7. Maintenance and cleaning



WARNING
Electric shock from live components
 If the device is energised during maintenance, cleaning or disassembly work, life-threatening electric shocks may result.
 → Turn off the device.
 → Disconnect all electrical connections.



WARNING
 Any modification to the plug may only be installed by qualified personnel in accordance with the relevant local and national electrical regulations!

- Order equipment and wear parts separately. included in the scope of delivery (marked as wear parts).
- Only use wear parts from Betaweld.
- Item numbers of the equipment and wear parts can be found in the current order documents or in the list

7.1 Maintenance and cleaning intervals

Daily	Semi-annually	Annually
Check the ground clamp for oxidation and clean if necessary.	Check and clean cables.	Have repeat tests carried out in accordance with DIN EN 60974-4.

7.2 Replacing the carbon fibre brush

If the carbon fibre brush is worn, it must be replaced. Caution: carbon fibre brushes that are not screwed in tightly enough can lead to contact problems in the thread.

1. Remove the screw sleeve.
2. Disassemble the carbon fibre brush with two open-end wrenches. Counter the adapter to avoid damage to the handle.
3. Install a new carbon fibre brush.
 → Chapter 4.1: Assembling the carbon fibre brush.

8. Faults and troubleshooting

8.1 Thermal fuse has blown

In the event of an overload or electrical short circuit, the thermal fuse interrupts the circuit, the green indicator light goes out. The thermal fuse button pops out of the housing. The thermal fuse can be triggered if there is not enough electrolyte on the carbon fibre brush or if the carbon fibre brush is pressed with a lot of force to the workpiece.

1. Switch off the device.
2. Allow the thermal fuse to cool for a moment.
3. Make sure that the carbon fibre brush does not touch the workpiece.
4. Press the thermal fuse button back into the housing.
5. Switch on the device.

8.2 Not enough power

There is no or insufficient power at the front of the carbon fibre brush.

1. There is not enough contact between the threaded piece and the carbon fibre brush.
 → Check the thread for oxidation, damage and loose fit.
 → Clean the thread with a stainless-steel wire brush.
 → Lubricate some copper paste or molykote grease on the thread.
 → Screw the threaded piece and carbon fibre brush firmly with the two AF10 open-end wrenches included in the set, see Fig. 4.

2. There is not enough contact between the ground clamp and the workpiece.
 → Check the ground clamp for oxidation and damage.
3. High current plugs are defective.
 → Check the high current connector for oxidation or damage.

8.3 Poor cleaning effect

Weld seam becomes matte:

- Do not remain in one place with the carbon fibre brush for too long.
- Cool the surface (spray water on the surface).
- Increase the amount of electrolytes.
- Use unused electrolyte.
- If necessary, use another electrolyte (from the original supplier's range)
- Only use electrolyte from original supplier.

Stains after rinsing:

- Rinse with plenty of water.
- Use water with lower hardness or distilled water.
- Process shorter sections.
- Rinse when the surface of the material is still hot.
- Wipe with **unused** paper towels. Use a fresh area of the towel for each wipe. Never wipe the workpiece again with a used area of the towel!

8.4 High material wear

Carbon fibre brush burns and electrode becomes hot:
 - Work with less pressure.

- Cool the carbon fibre brush in the electrolyte container longer or more frequently.
- Use more electrolyte.

9. Disposal and further information



Appliances marked with this symbol are subject to the European Directive 2012/19/EU Waste Electrical and Electronic Equipment.
 - Do not dispose of electrical appliances with household waste.
 - Collect components of electrical appliances separately and recycle them in an environmentally friendly manner.
 - Observe local regulations, laws, provisions, standards and guidelines.
 - For information on the collection and return of waste electrical and electronic equipment, contact your local authority.

9.1 Disposing of electrolytes

- Electrolytes must be disposed properly.
- Wastewater must not be released into the canalisation without being tested.
- Pay attention to local regulations, laws, provisions, standards and guidelines for releasing wastewater into

the canalisation.
 - Never dispose electrolytes/waste water unchecked into the canalisation or the environment
 - More information on wastewater treatment are available on request from Betaweld.

9.2 Process vapors

Process vapors that are generated during the cleaning of stainless steels usually do not have to be extracted.

More information on this topic are available on request from Betaweld.

9.3 Passivation of stainless steel

After a correct electrochemical cleaning, a repassivation of the stainless steel can be guaranteed without further reworking.

Examination reports and further information are available on request from Betaweld.

10 Warranty

This product is an original Betaweld product. Betaweld warrants that this product has been manufactured in accordance with the applicable regulations and that it is free from defects in material and workmanship. If a defect occurs for which Betaweld is responsible, Betaweld is obliged to remedy the defect or supply a replacement at its own expense and at its own discretion. The warranty covers manufacturing defects, but not damage resulting from natural wear and tear, overloading or improper use. The warranty period is defined in the general terms and conditions.

Exceptions for certain products are regulated separately. The warranty also expires in the event of the use of spare and wear parts that are not original Betaweld parts, as well as in the event of improper repair of the product by users or third parties. Wear parts are generally not covered by the warranty. Questions on warranty and service can be addressed to Betaweld at www.betaweld.com.au.



BETAWELD.COM.AU

1300 120 130 | INFO@BETAWELD.COM.AU