



AUTOMOTIVE ACCESSORY
MANUFACTURE & DISTRIBUTION

AIRPLEX INDUSTRIES LTD
21 Saleyards Road, Otahuhu, Auckland 1062, New Zealand
PO Box 11286, Ellerslie, Auckland 1542 New Zealand
PH +64 (9) 276-9826 Fax +64 (9) 276-9836
info@airplex.co.nz www.airplex.co.nz

FITTING INSTRUCTIONS FIT1356

PLEASE READ INSTRUCTIONS COMPLETELY BEFORE INSTALLATION

**ROLLING LID – LDV TERRON 9
ELECTRIC – WITH BED LINER**

RL130E-P

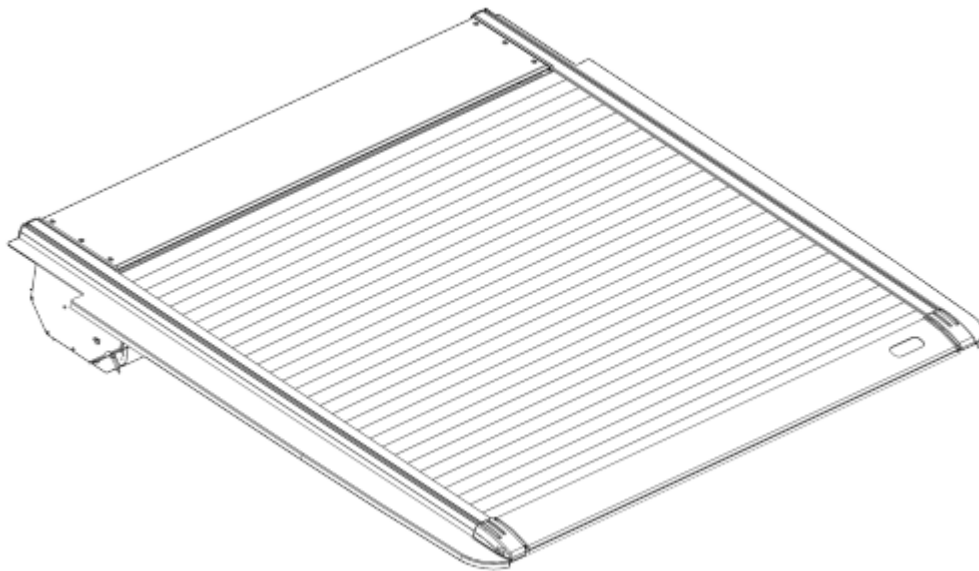

1. Matters need attention:

1. Please install the parts in a safe environment, and wear the corresponding safety protective equipment.
2. Please read this manual carefully before installing the product, pay attention to protect the surface of the vehicle, and avoid scratches during the installation process.
3. Check whether the parts in the package are complete before installation.
4. Please regularly check whether all the parts connected to the car are loose to ensure the safety of use.
5. Use traces between the slide track and the rolling curtain are normal test traces.
6. This curtain has no load-bearing function, do not place the heavy object above the curtain.
7. The drainage pipe passes through the drainage hole of the rear tail box.
8. Before folding up the curtain, make sure to ensure that the surface is clean to avoid foreign bodies involved in the box.



2. kindly reminder:

1. When the curtain is opened or closed, pay attention to check whether there is foreign body, avoid the human body contact with the opening and closing area, and avoid pinching.
2. When the box body and the side rod slide rail are installed, the rolling shutter has the automatic return function. Please pay attention to the stability to prevent clamping.
3. Please do not close the pet or person in the closed rear tail box, which may cause suffocation.
4. The number of people installing the curtain is recommended to be 2, and the installation time is about 45 -60 minutes.











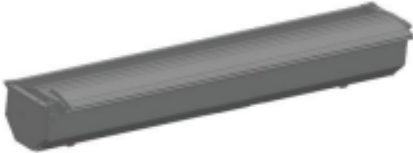































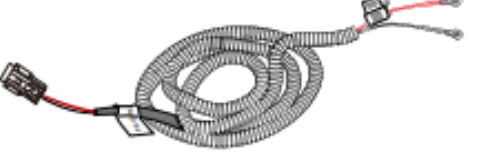









AUTOMOTIVE ACCESSORY
MANUFACTURE & DISTRIBUTION

AIRPLEX INDUSTRIES LTD
21 Saleyards Road, Otahuhu, Auckland 1062, New Zealand
PO Box 11286, Ellerslie, Auckland 1542 New Zealand
PH +64 (9) 276-9826 Fax +64 (9) 276-9836
info@airplex.co.nz www.airplex.co.nz

Table of Contents

- 1. Product Introduction.....1
- 1.1 Bill of Material.....1
- 1.2 Product Component.....4
- 2. Installation.....5
- 2.1 Preparation.....5
- 2.2 Assembly.....9
- 2.3 Install the front splash guard.....15
- 2.4 Assemble the bracket.....18
- 2.5 Product loading.....25
- 2.6 Wiring.....30
- 2.7 Adjust/check (Gage M4 or U).....34
- 3. Description.....38
- 3.1 Introduction to remote control.....38
- 3.2 Key Fob Control.....39
- 3.3 Front Button Control.....39
- 3.4 APP/Wechat Program.....39
- 4. Maintenance and repair.....41
- 4.1 Solutions to common problems.....41
- 4.2 Rolling shutter failure analysis.....41
- 5. Helpful Maintenance Hints.....42

1. Product Introduction				
1.1. Bill of Material				
M1		1X	M2	
M3		1X	M4	
M5		1X		
Bill of Material-Canister				
A		6X	B	
C		2X	D	
E		2X		
Foam				
K1		2X	K2	
	Foam 430x46x3			Pre-EVA single-sided vinyl 1X
K3		1X		
	Foam 1610x40x10			
K4		1X	K5	
	Foam 1650x40x5			Pre-strip 1X
Bill of Material-Brackets				
F		2X	G	
H		2X	I	
J		L1+R1	K	
L		4X	M	
N		8X	O	
P		26X	Q	
R		12X		

S  28X7X4 10X	T  2X	U  L1+R1				
Electronic						
Y1  harness (in gray color) 1X	Y2  Original vehicle signal line (yellow) 1X					
Y3  Switch button line (white) 1X	Y4  Signal extension line (white) 1X					
Y5  20X	Y6  2X					
Bill of Material-Tools						
Z1  Φ20mm 1X	Z2  S=4 1X	Z3  S=5 1X	Z4  S=5 1X	Z5  S=8/10 1X		
Maintenance						
 Sealant 3X	 Lubricant 1X					
Other Assistive tools (Provided by Customer)						
 H ₂ O						 Φ28

1.2 Product Component.

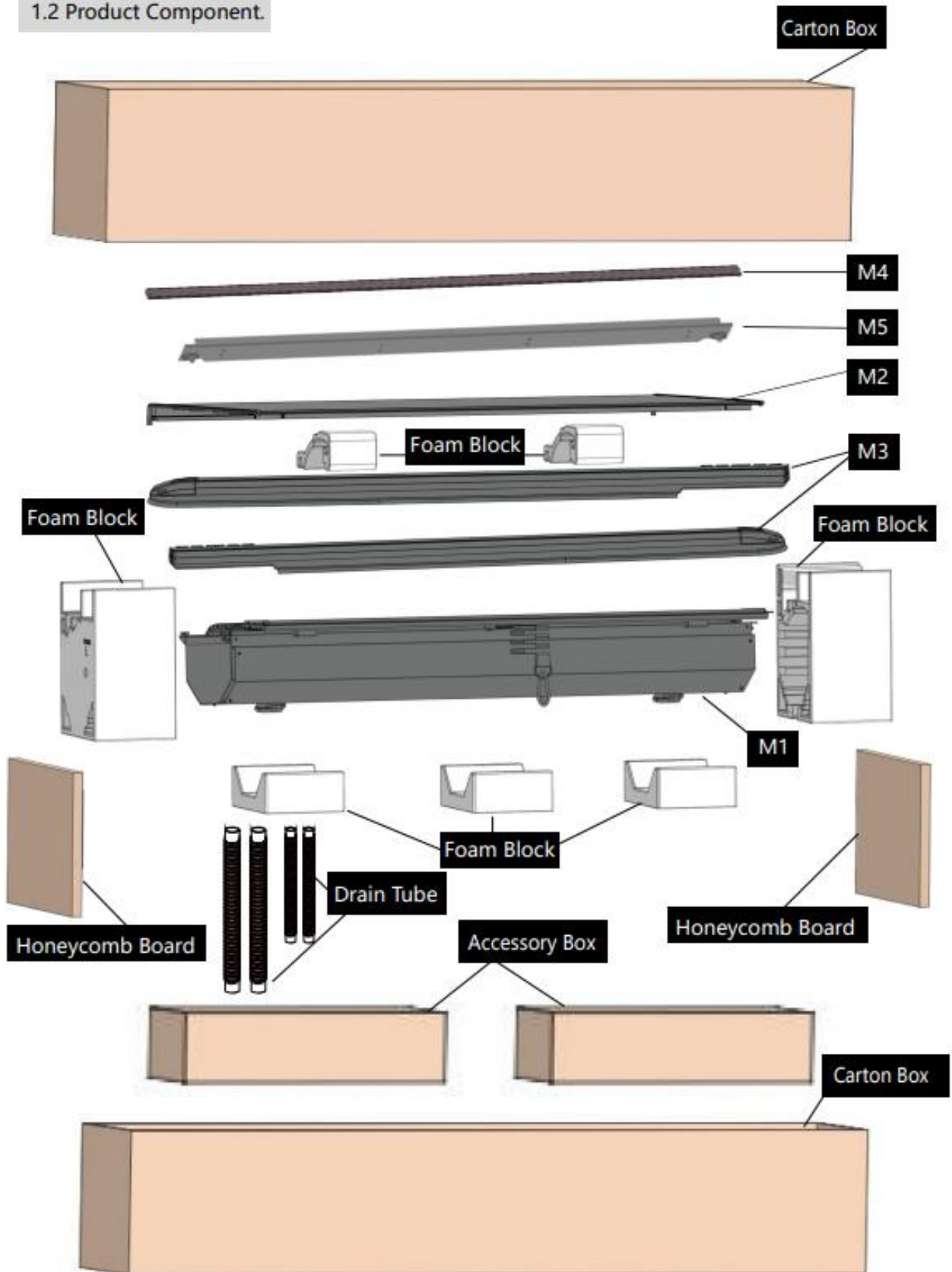

2. Installation

2.1 Preparation.

1

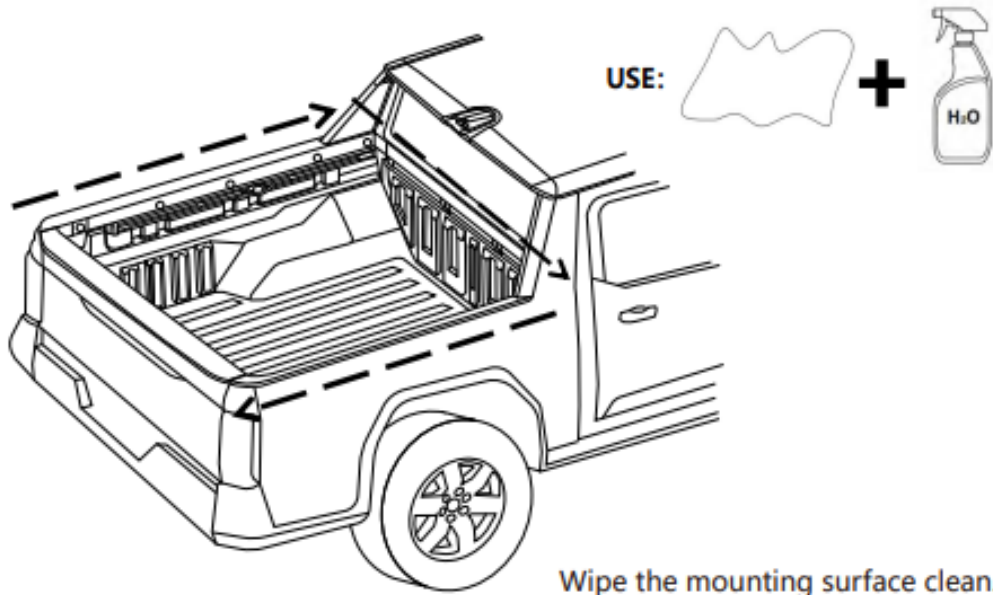

2

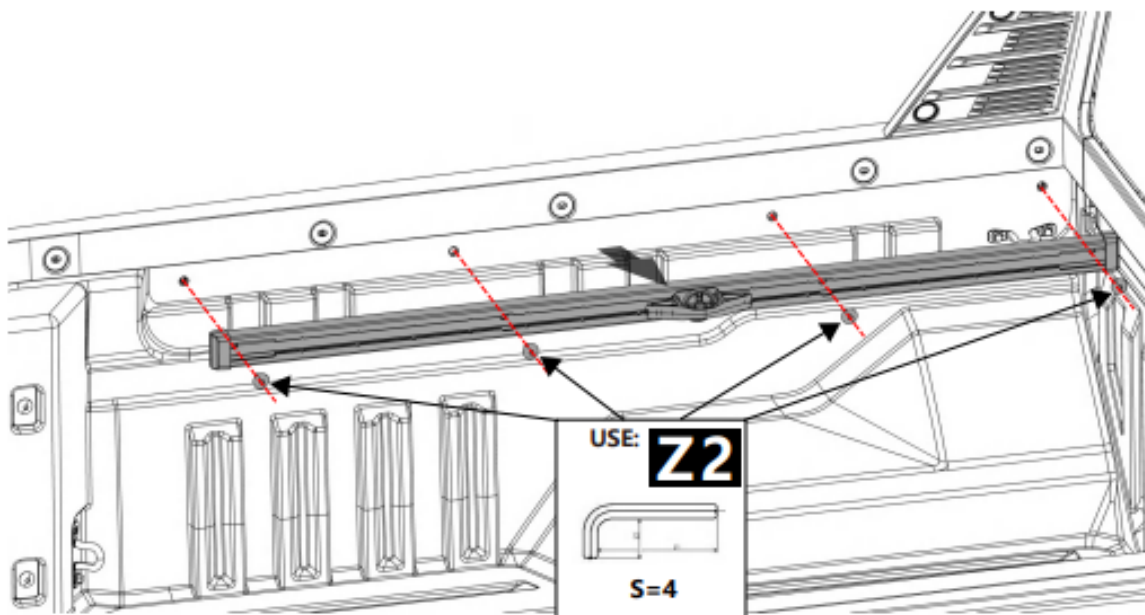

Unscrew the original screws on the seat rail and remove it. Same as the right side.

3

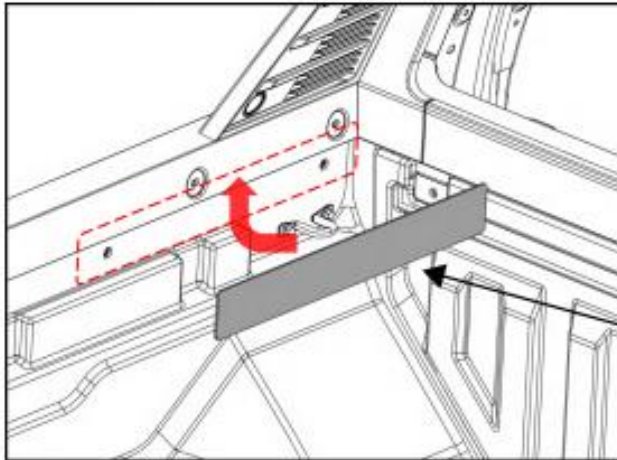

K1

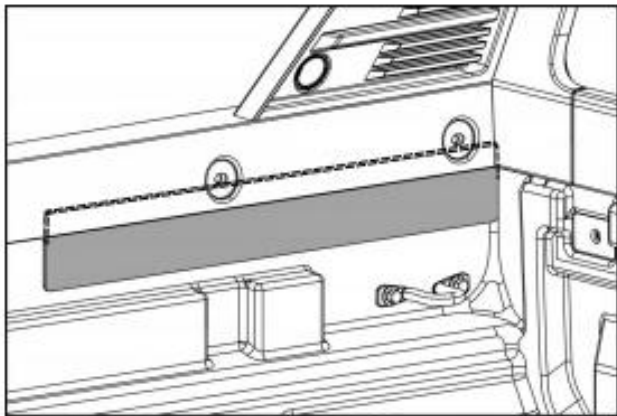

Accessory K1 single-sided foam is positioned using the box edge as a reference (as shown). Adhere the foam to the inner side of the vehicle compartment wall; Same as the right side.

4

Two methods for installing the front waterproof foam.
Option 1:

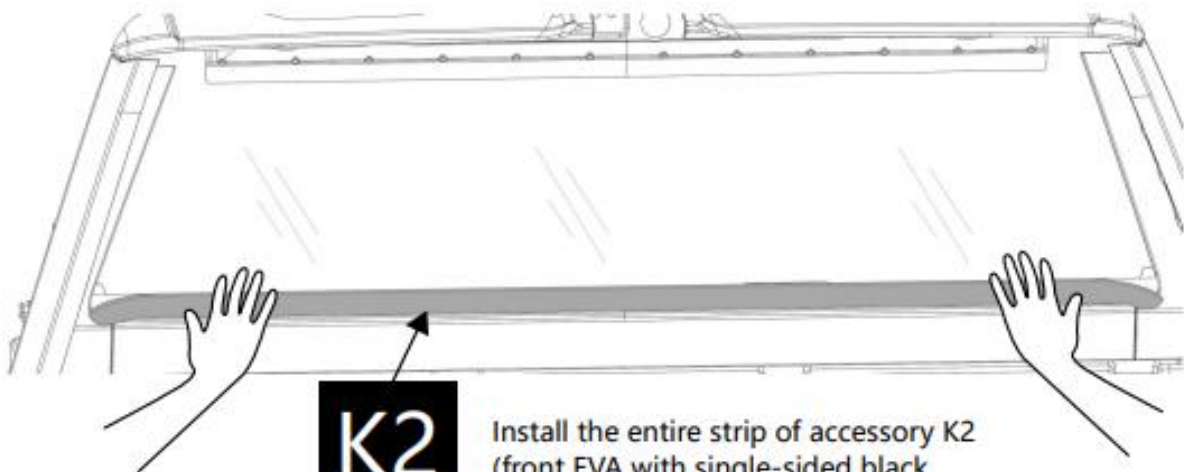

K2

Install the entire strip of accessory K2 (front EVA with single-sided black adhesive) to the bottom edge of the rear window, as shown in the figure.

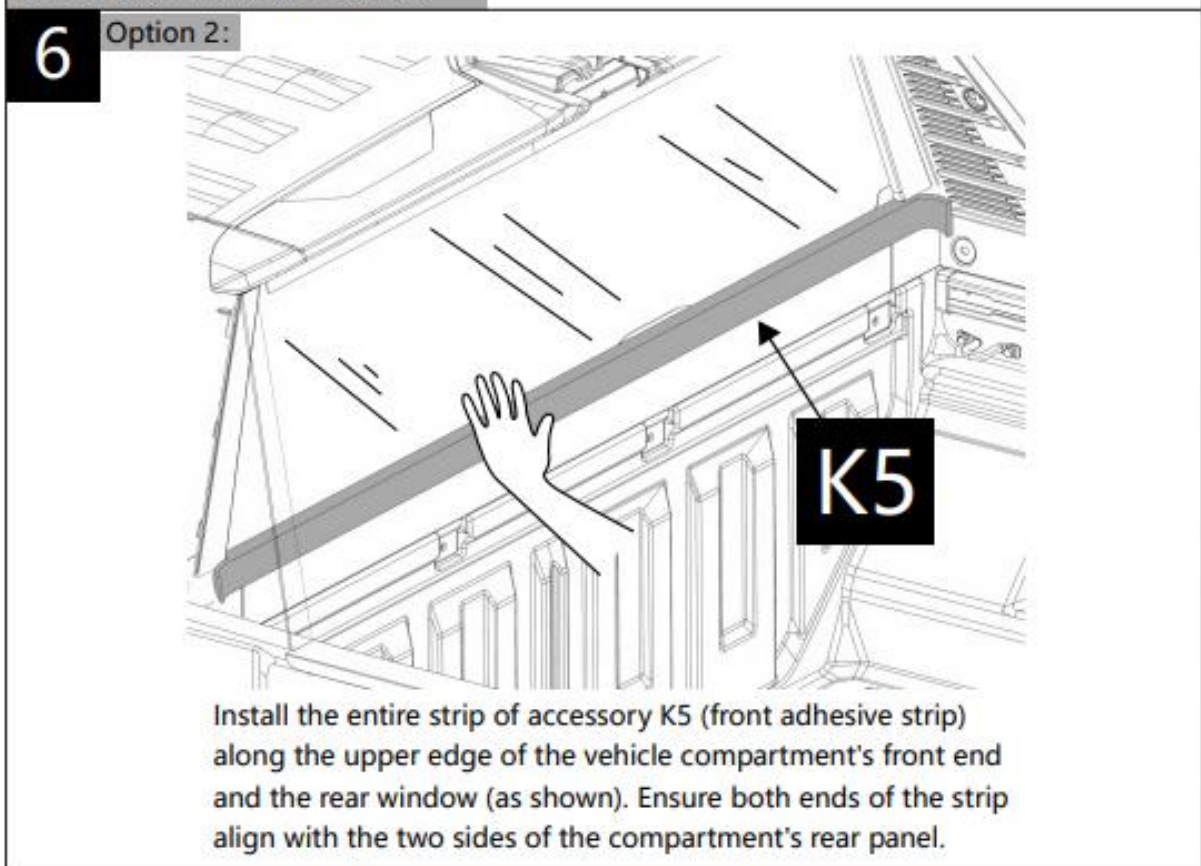
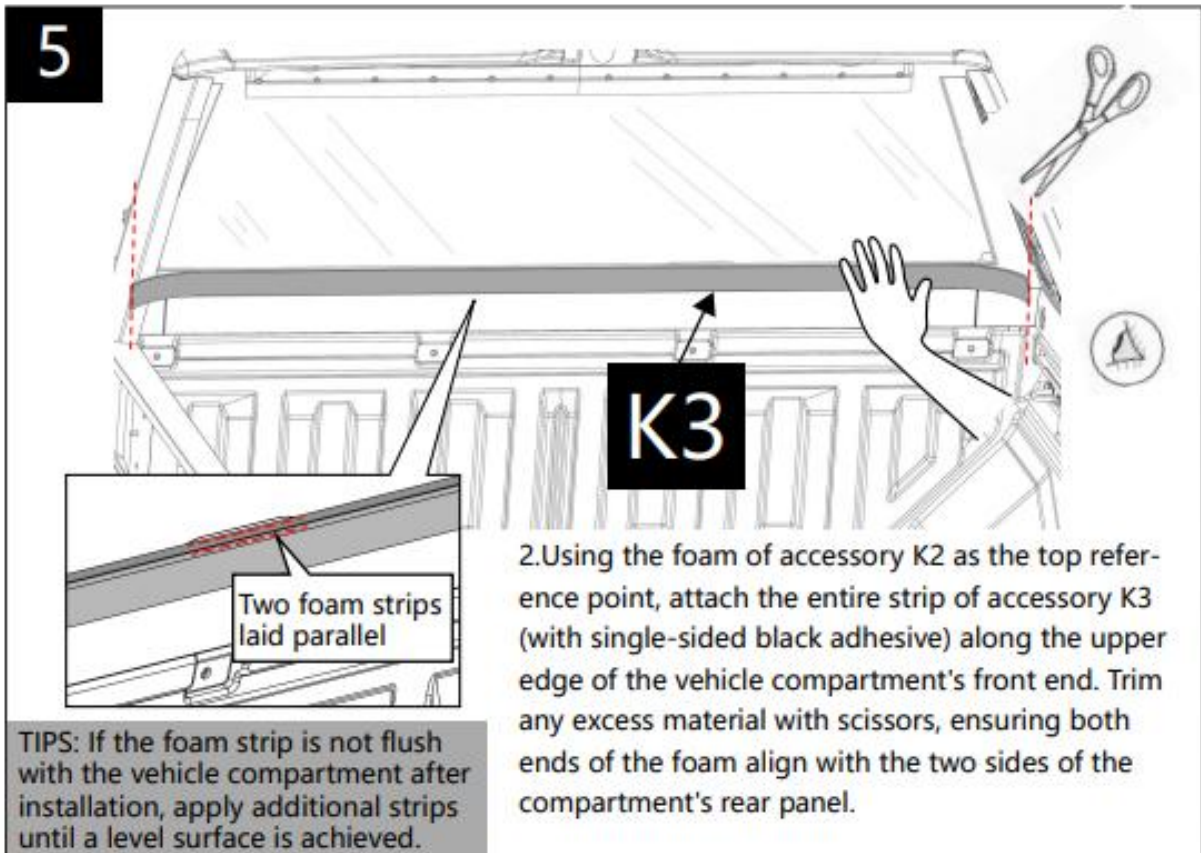

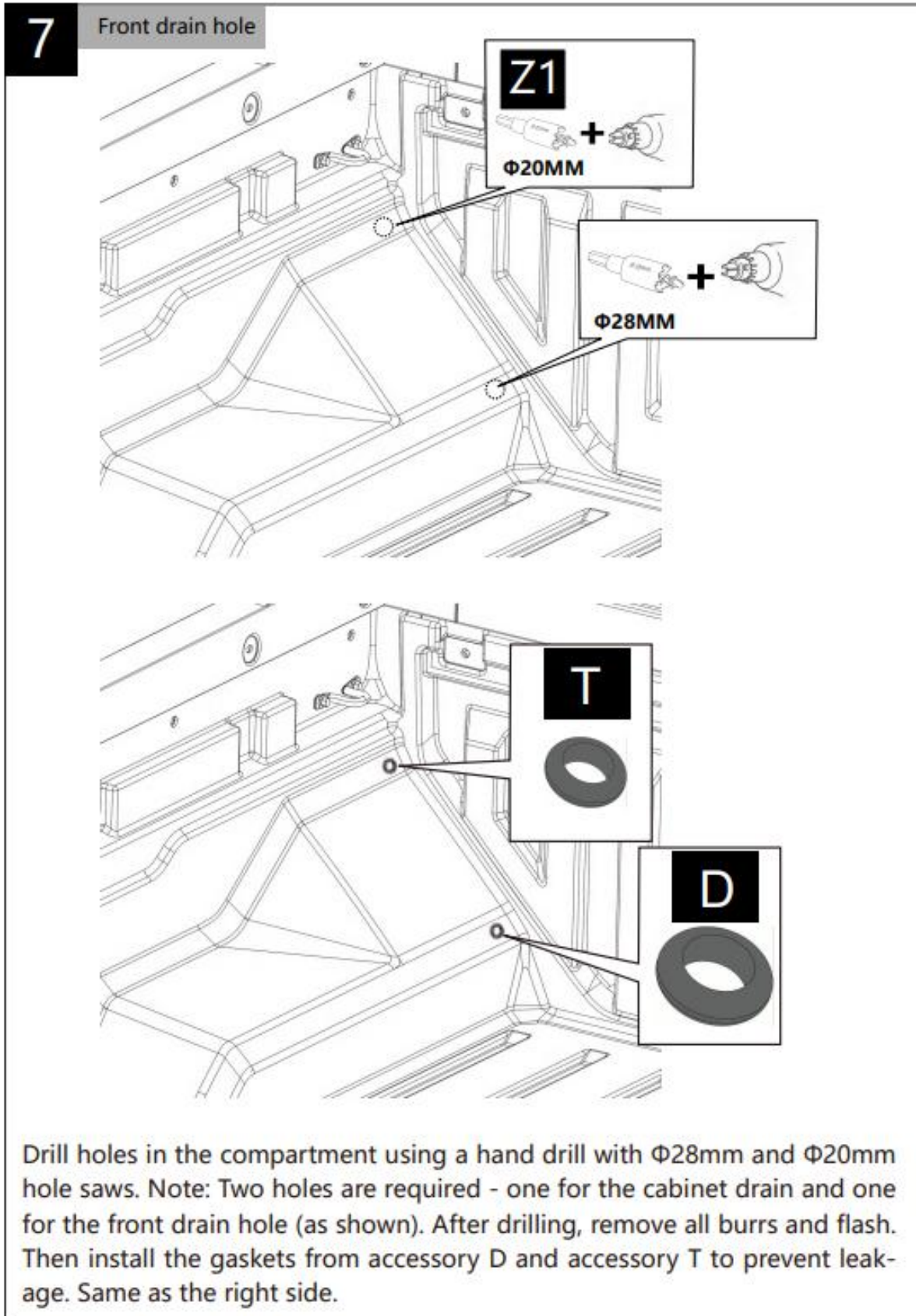

8

Rear drain hole

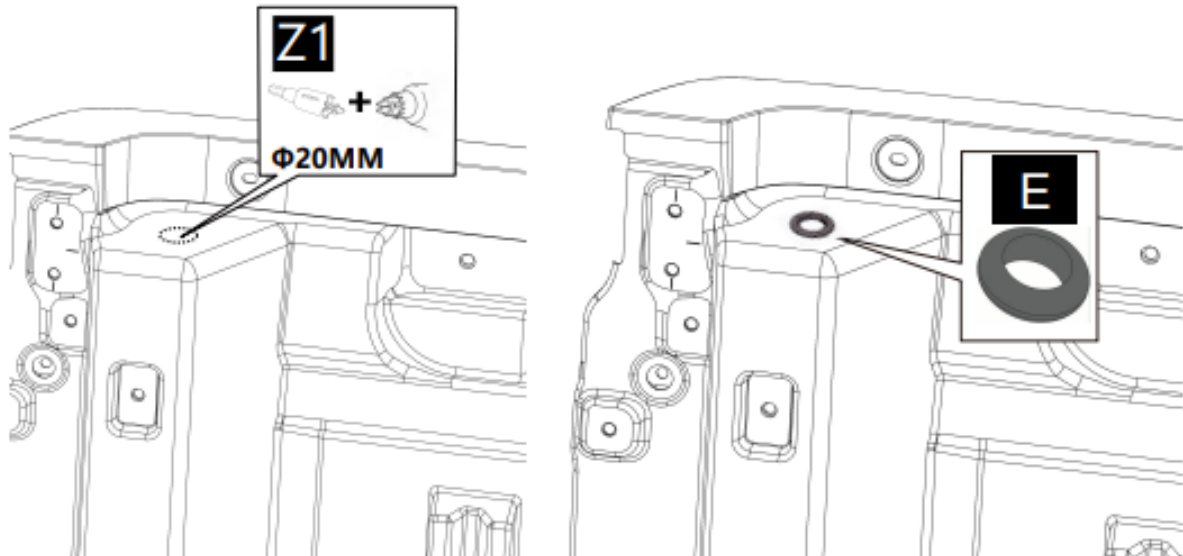

Drill holes in the compartment using a hand drill with a $\Phi 20\text{mm}$ hole saw (as shown). After drilling, remove all burrs and flash. Then install the gasket from accessory E to prevent leakage. Same as the right side.

2.2 Assembly

9

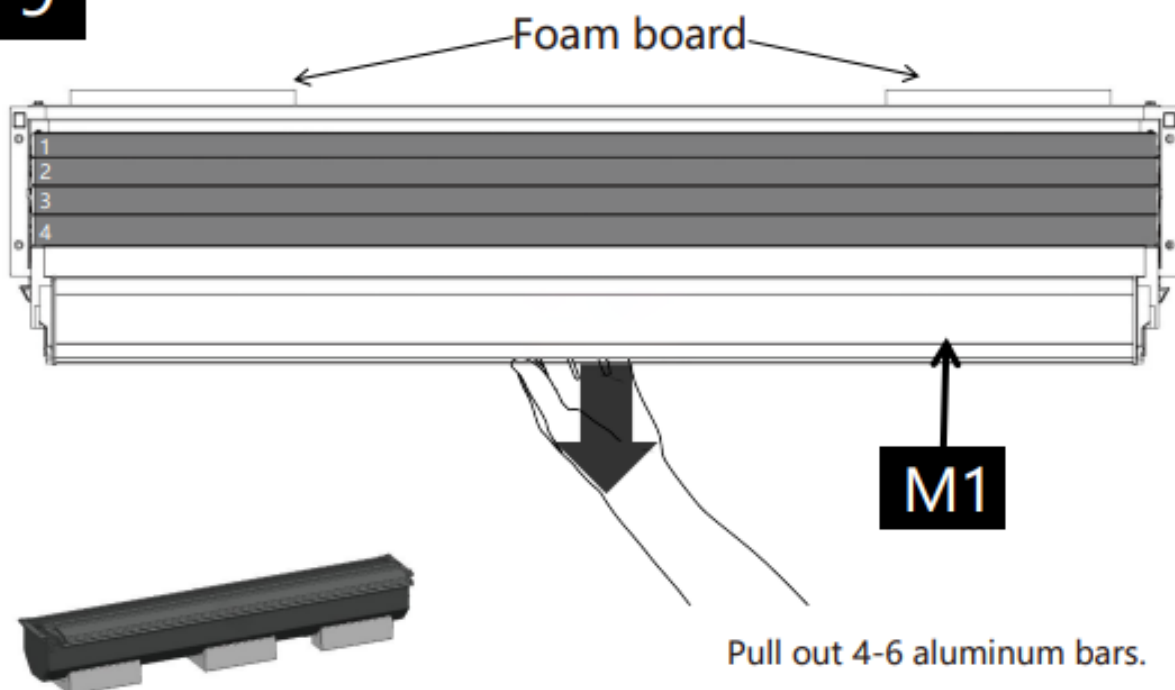

Tips: Put the canister on the foam block for assembly to avoid scratch.

10

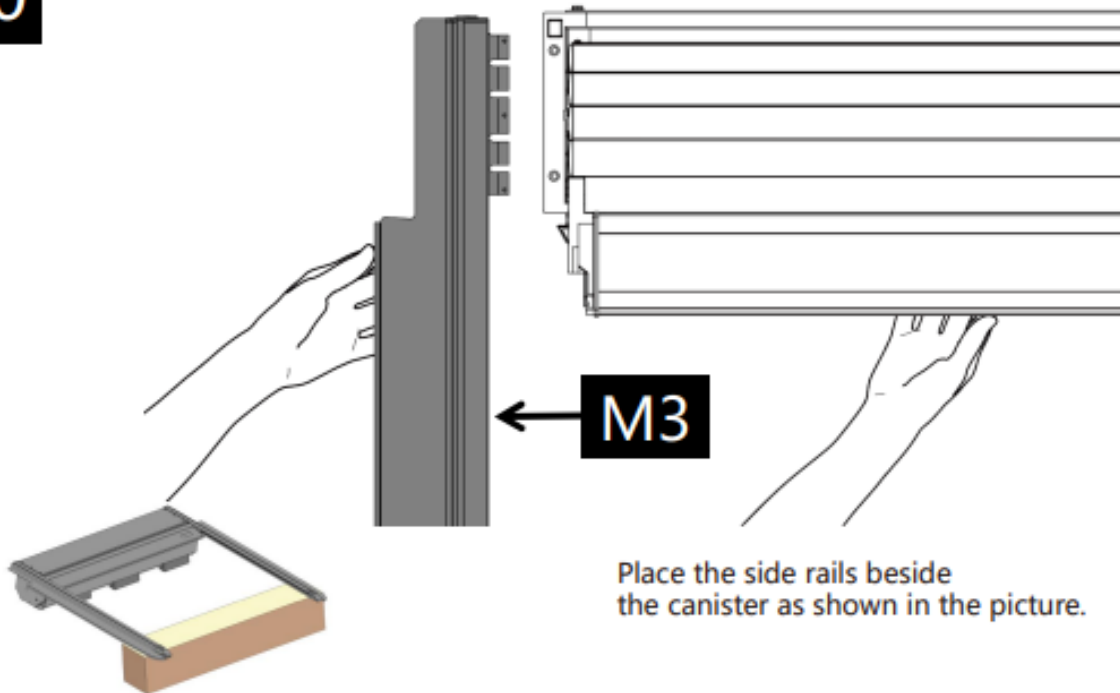

Place the side rails beside the canister as shown in the picture.

Tips: Place the side rails on carton box to avoid scratch.

11

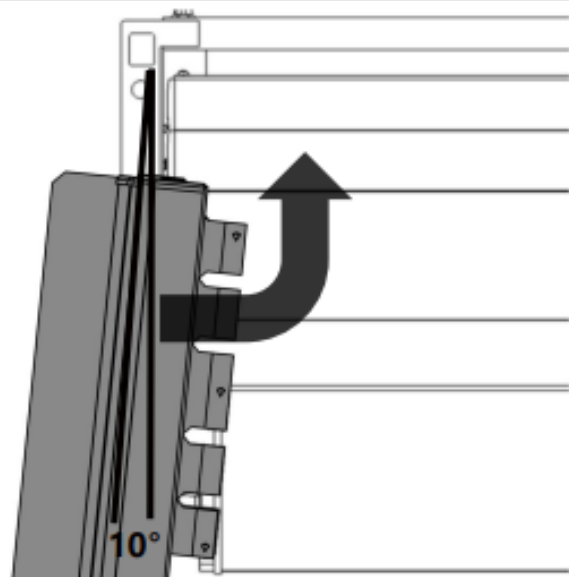
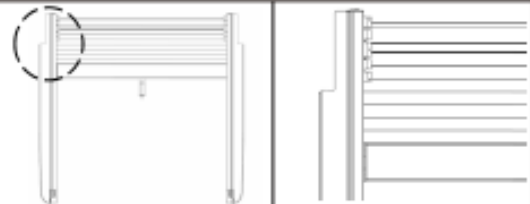

Tips: avoid using brute force operation, damage the product.

Lift the side rail up 10° and then out 10°,-
Place the roller into the side rail chute.

12

Tips: avoid using brute force operation, damage the product.

Align the side rail groove with the raised T-block and push the side rail until it can not be moved any forward.

13

Sliding nut

Note: After the first screw is halfway in, start installing the second screw. Fully tightening the first screw may make installing the second screw difficult.

USE: **Z3**
S=5

Tighten the bolts with wrench.

TIPS: This operation need to reverse the canister. If the bolts can not be fixed, please adjust the side rail and the canister hole alignment.

14

Before completely fixing the side rails, it is important to ensure that the roller bars are on the same straight line (distance A=A)

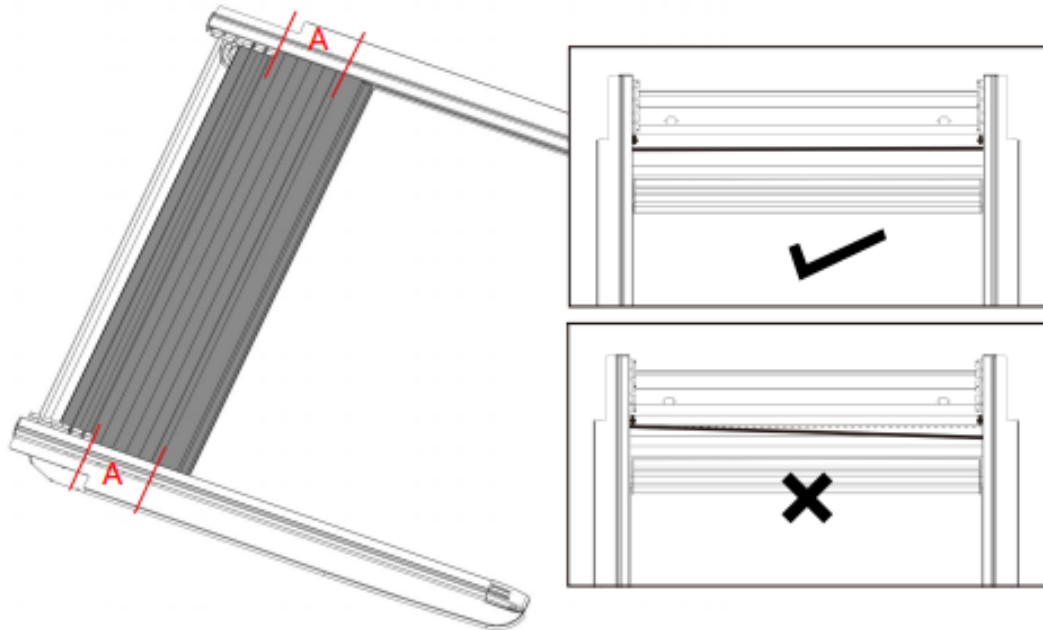

15

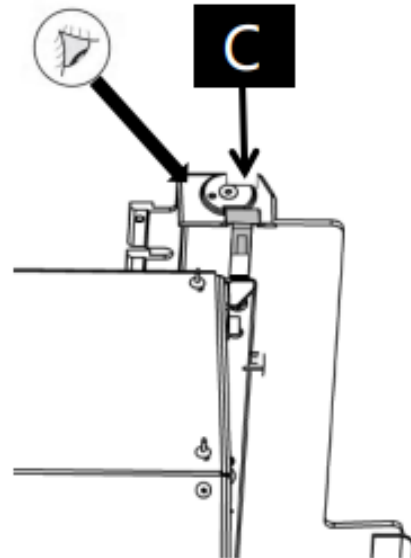
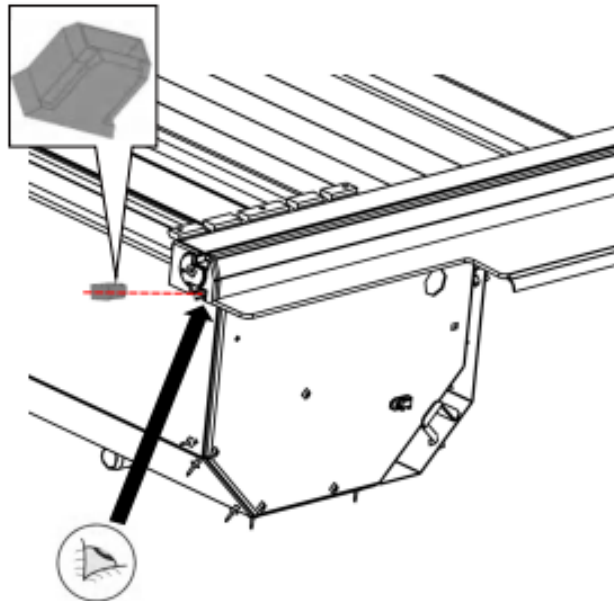

Tips: (c) the narrow part of the stopper should face down

Place (C) stoppers in the front ends of the side rods as shown.

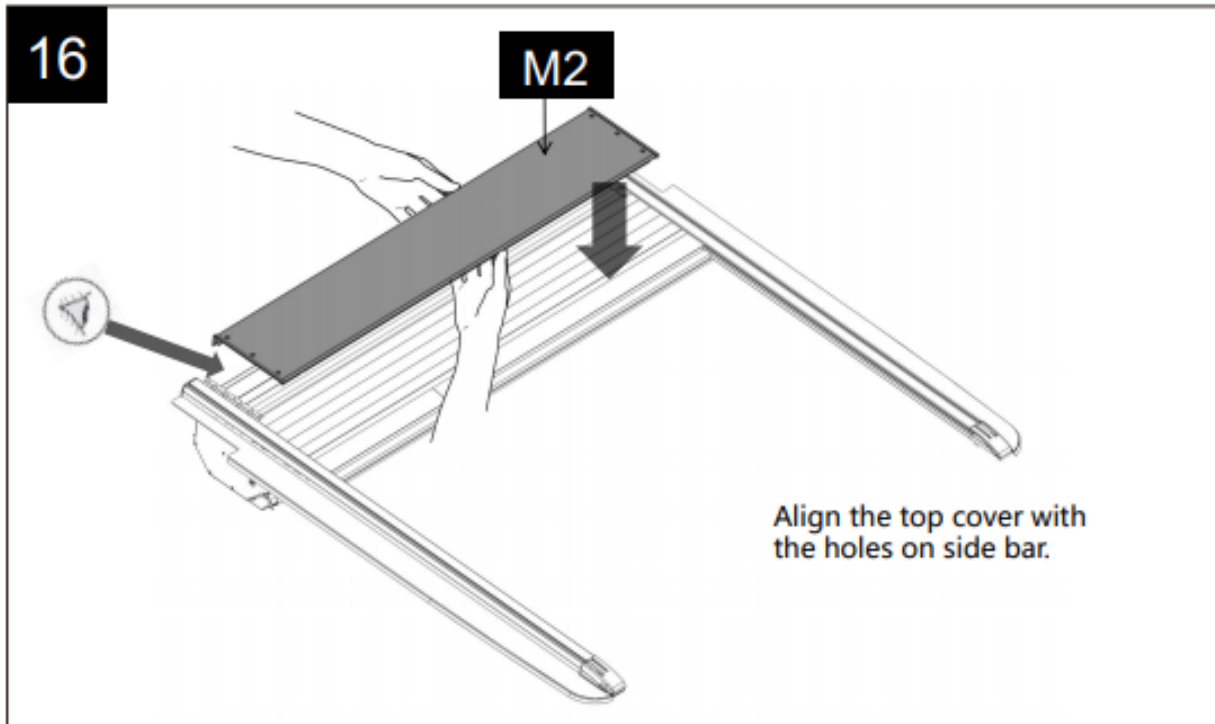

TIPS: Match the top cover exactly to the canister

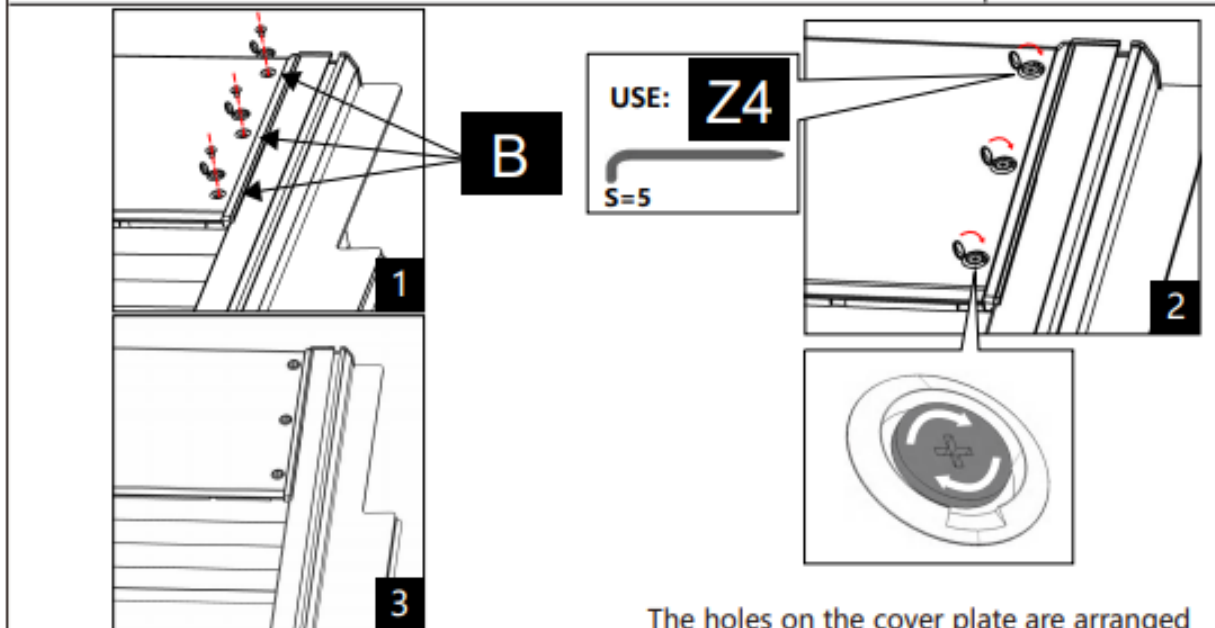

TIPS: Pre-tighten the bolts on left side. Then on right side. And fix all the bolts finally.

The holes on the cover plate are arranged with (B) base and bolts in turn. Tighten the bolts using a (Z4) cross wrench. Finally close the (B) lid.

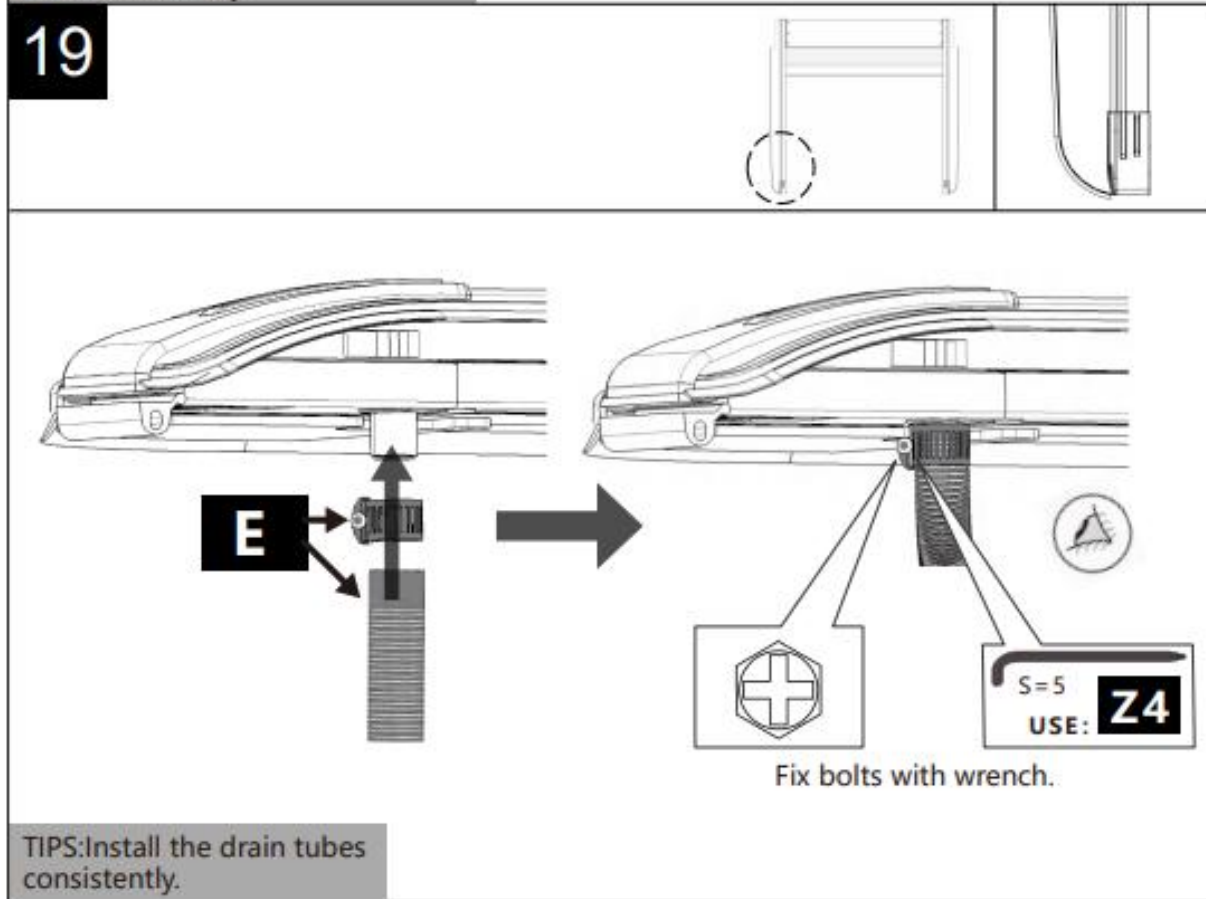
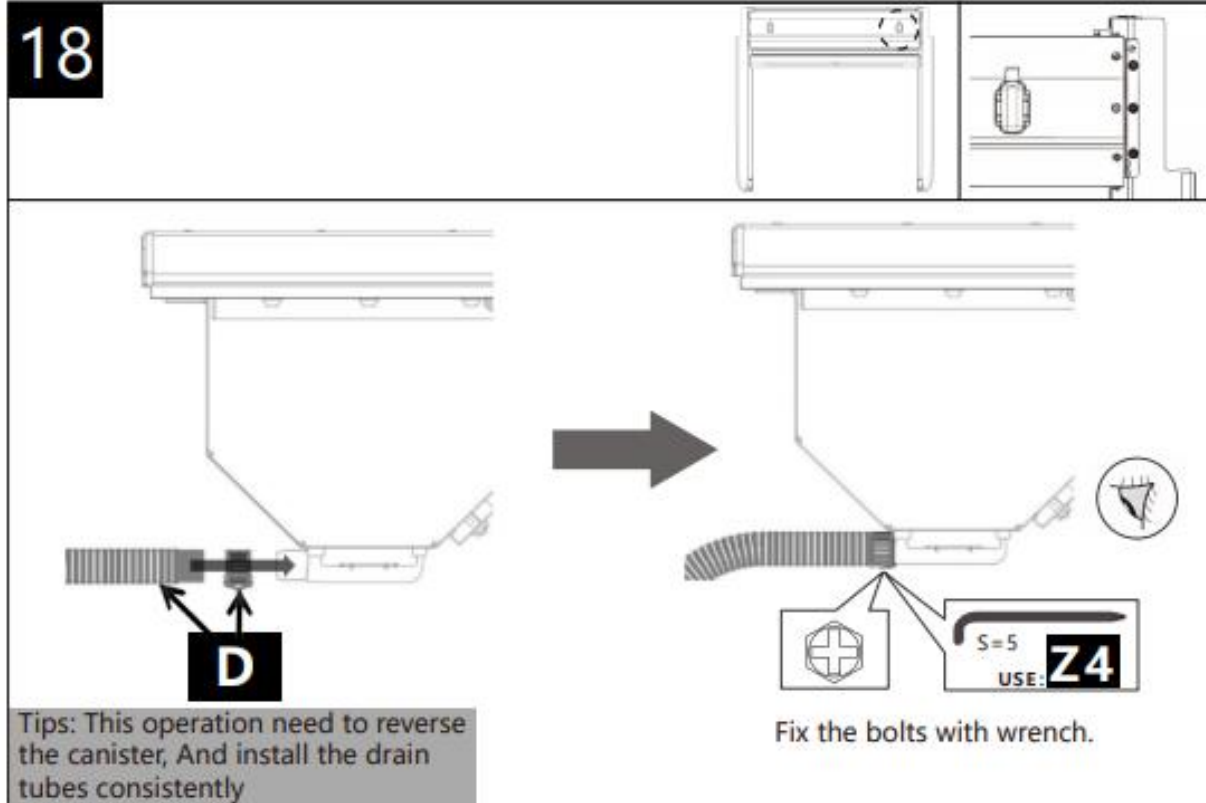

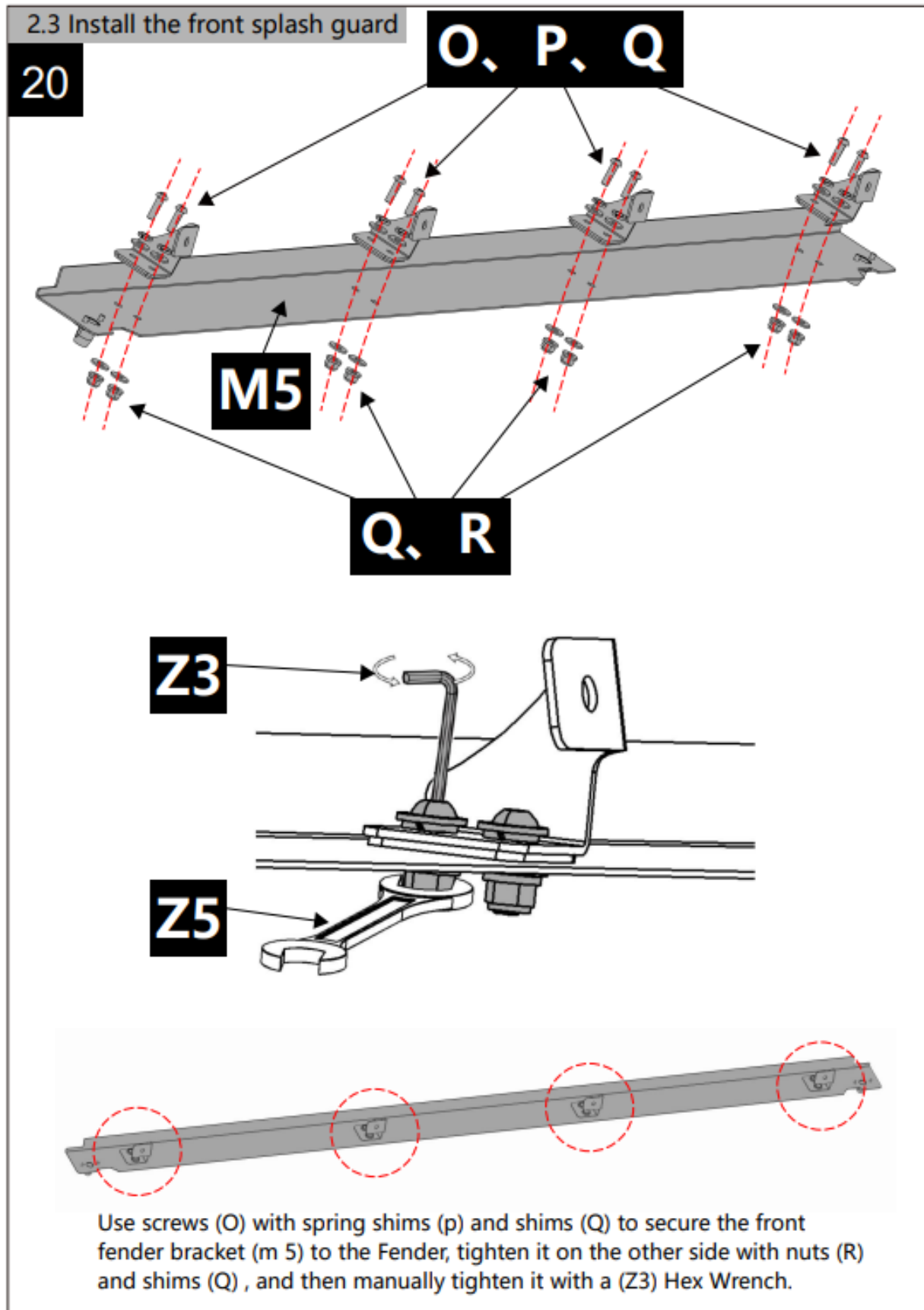

21

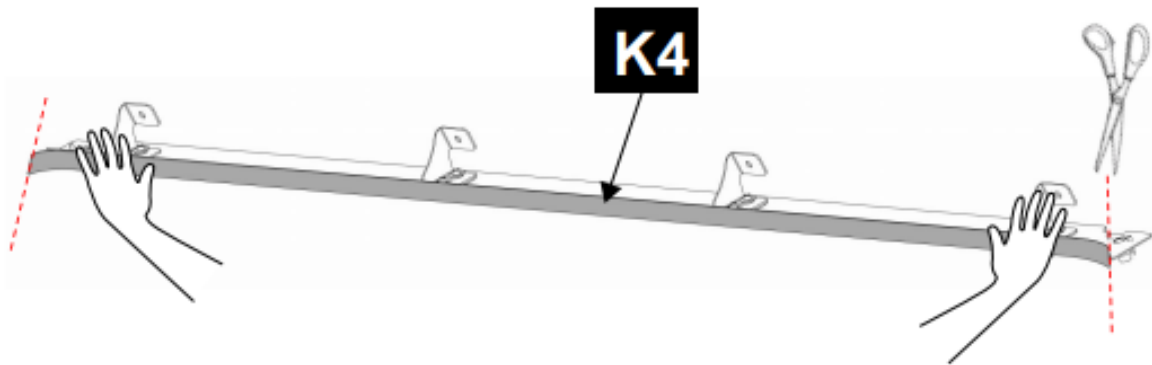

Apply the entire strip of (K4) single-sided foam to the outer side of the front splash shield, as show in the picture.

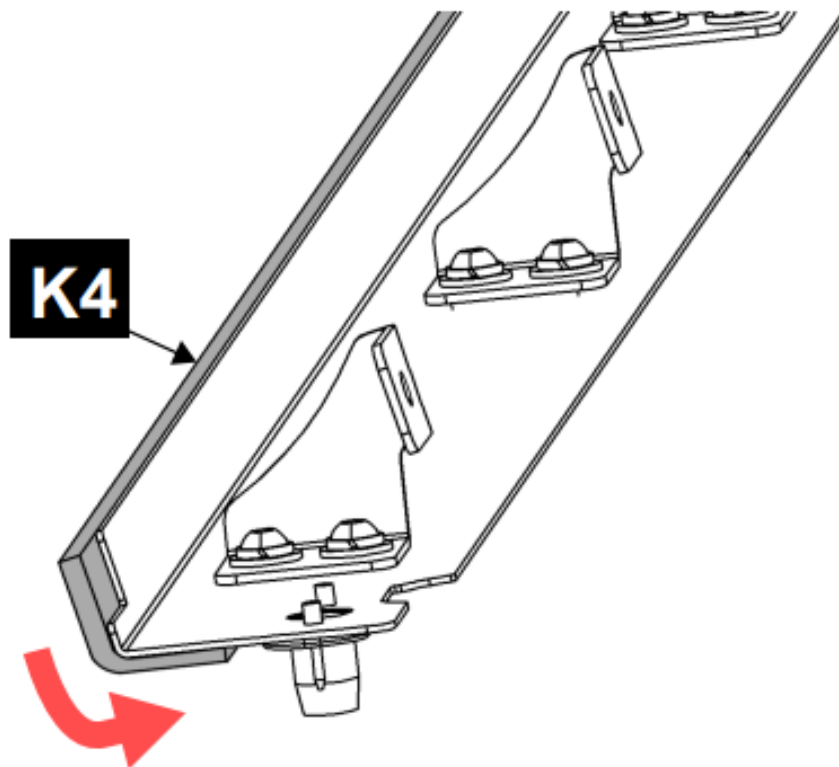

Bend and adhere the lower end of the foam to the bottom of the splash shield (see illustration). Same as the right side.

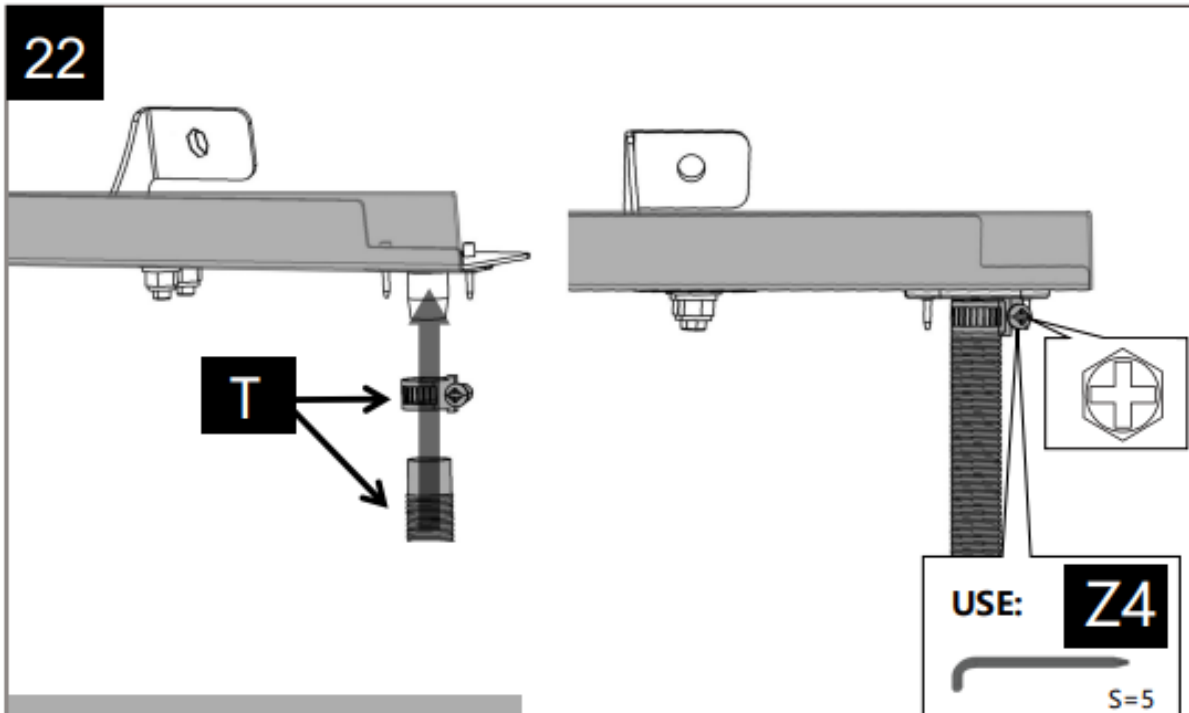

Using a cross-head spanner (Z4), tighten the pipe bolts (T).

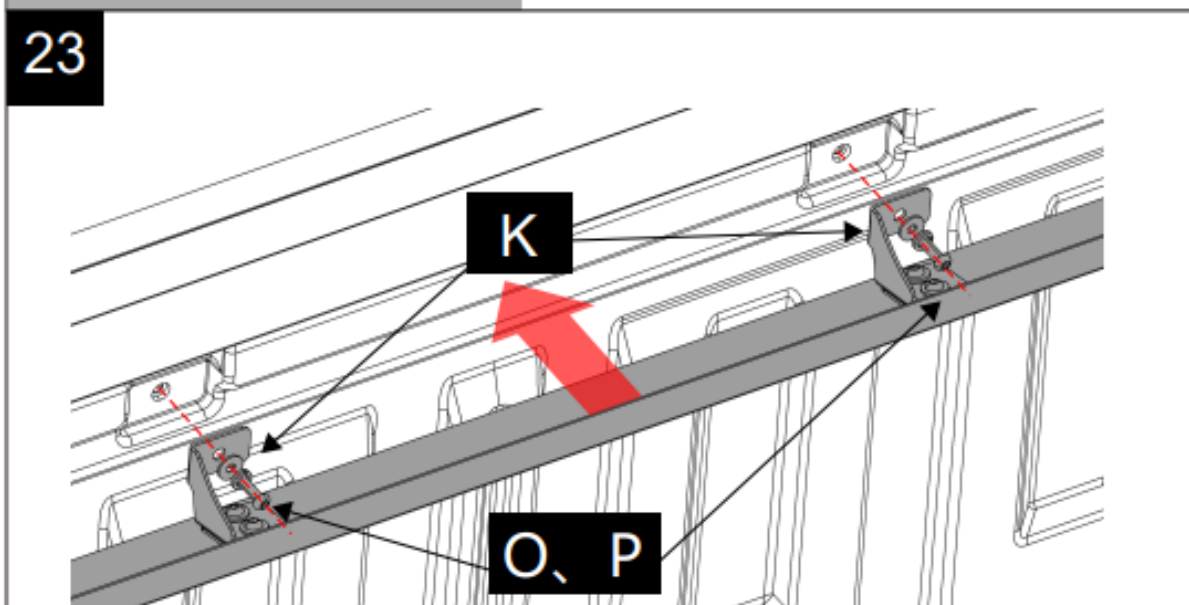

Using (O) screws, (p) spring shims, (Q) shims through the front fender bracket screw holes, screw on the front of the car on the original car screw holes, a total of four.

24

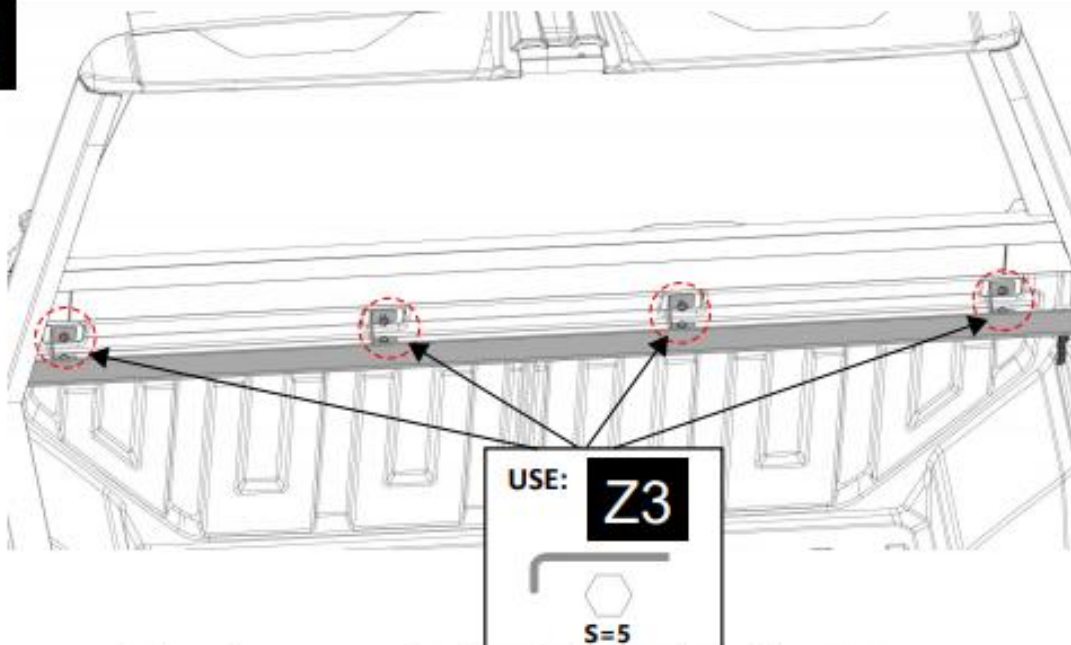

Tighten the screws on the front fender bracket with a (Z3) Hex Wrench and secure the front fender to the front edge of the car.

2.4 Assemble the bracket

25

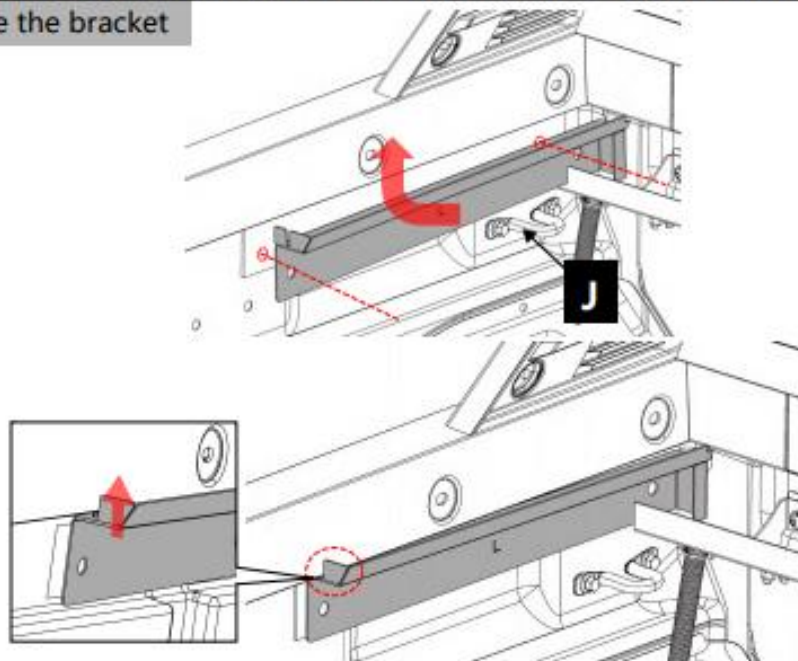

Tips:1. The end of the bottom water-catching bracket must hook onto the edge of the compartment and be pushed inward until it is fully seated.2. Align the screw holes of the bracket with the vehicle's original screw holes through the foam, facilitating the installation of the original screws in subsequent steps.

Install the (J) bottom water-catching bracket at the position of the side water-blocking foam on the bottom left and right sides of the front compartment. Repeat the same procedure on the right side.

26

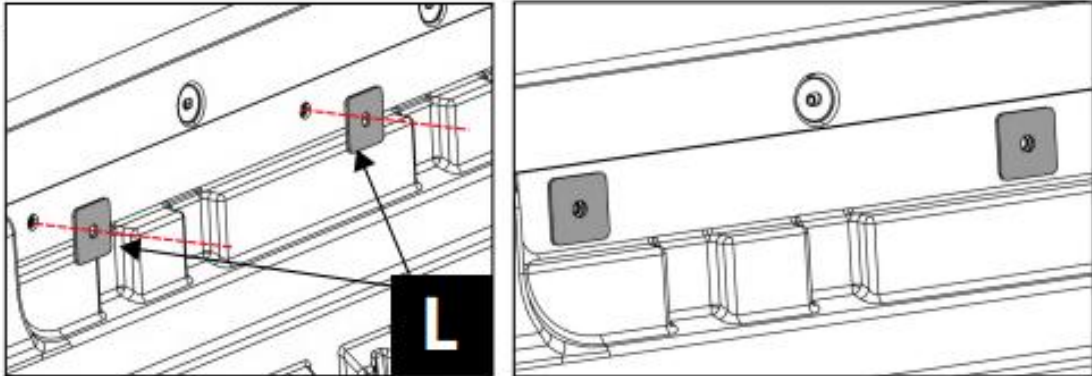

Install two (L) washers at each of the original seat rail screw holes on both sides. This ensures the installed rail remains level. Repeat the same procedure on the right side.

27

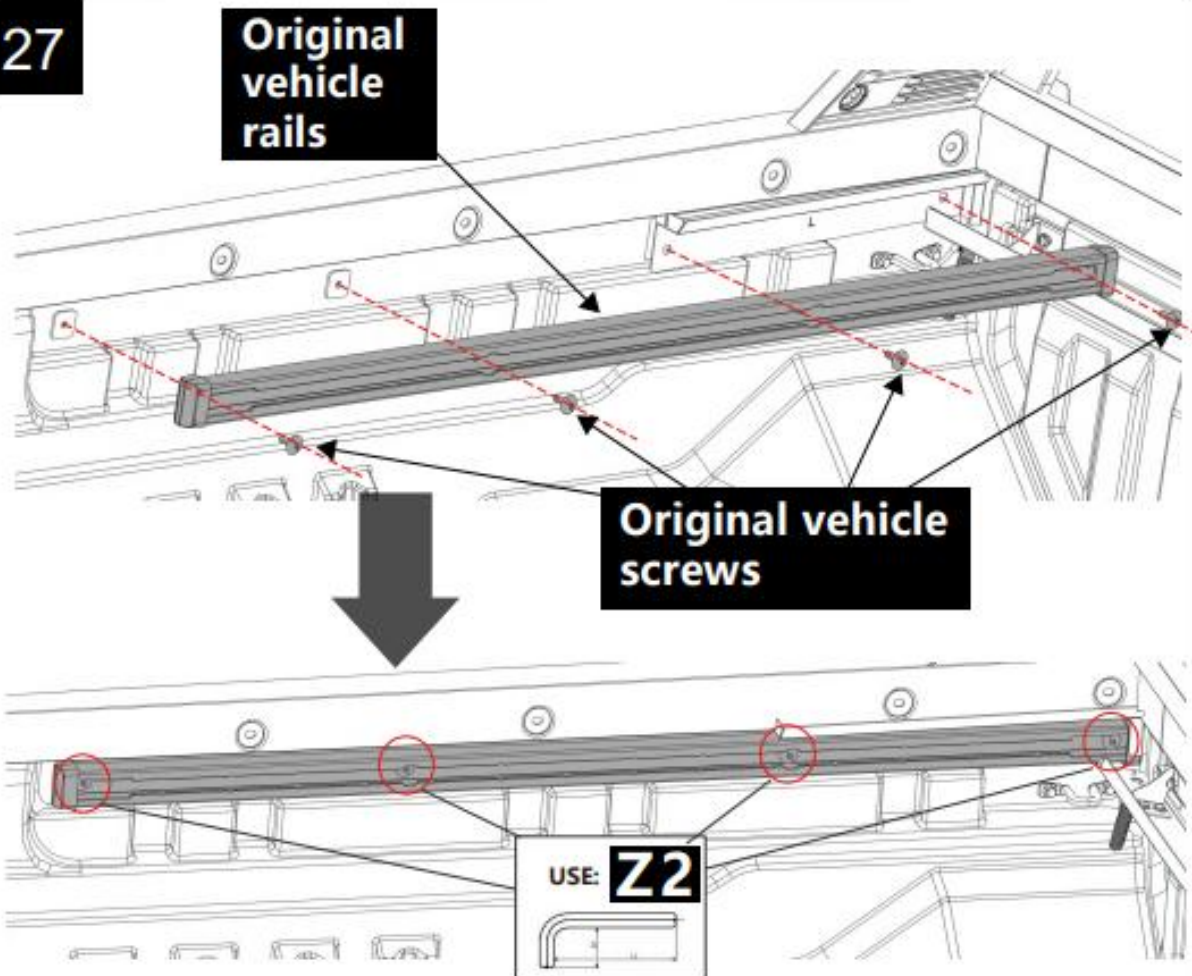

Install the original seat rails on both sides of the compartment using the original screws. Secure them with a (Z2) wrench. Repeat the same procedure on the right side.

28

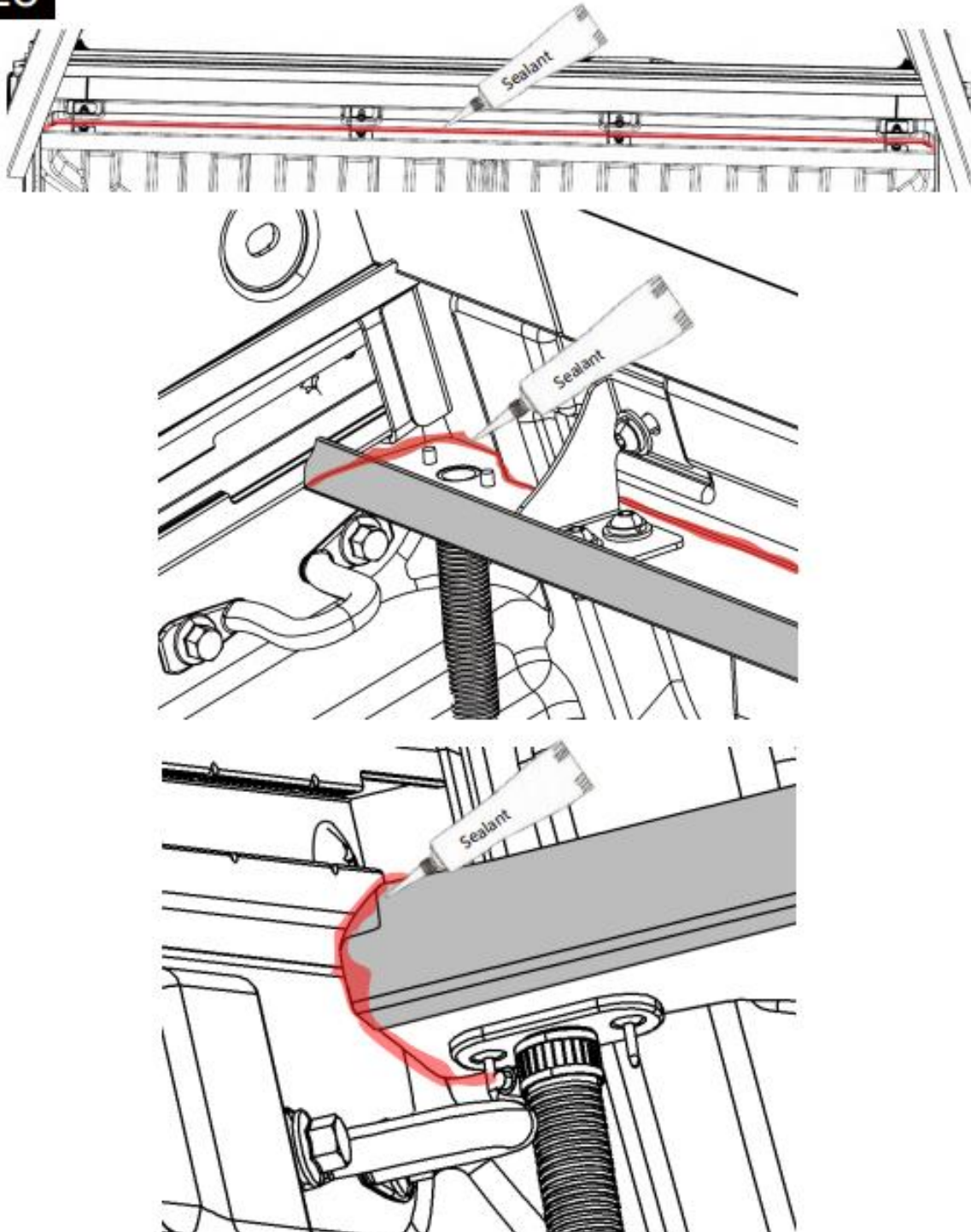

Apply sealant to all contact points between the front splash shield and the compartment (including the original seat rails) to prevent water leakage. Repeat the same procedure on the right side.

29

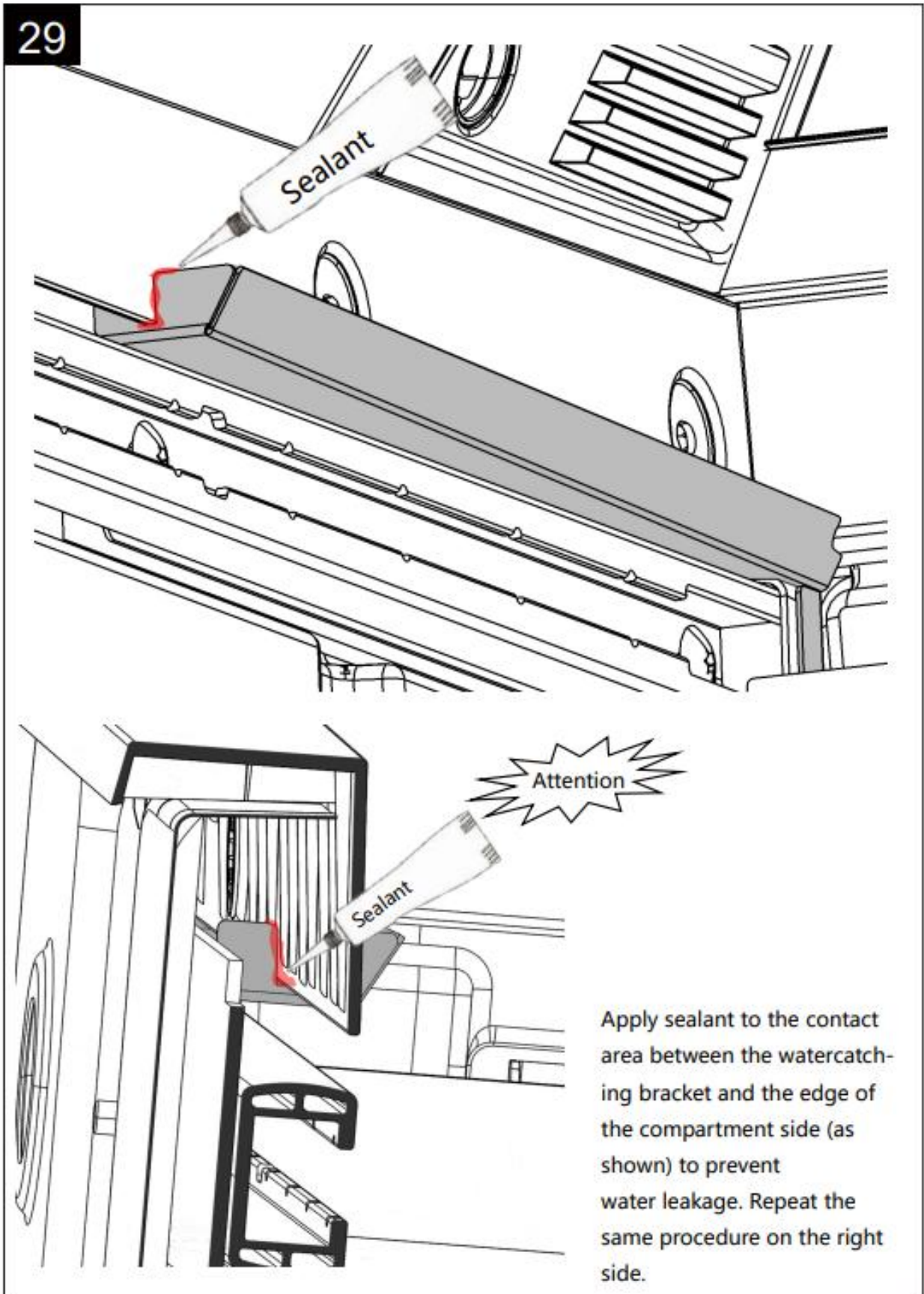

30

Install the front bracket as shown in the figure below. Same as the right side.

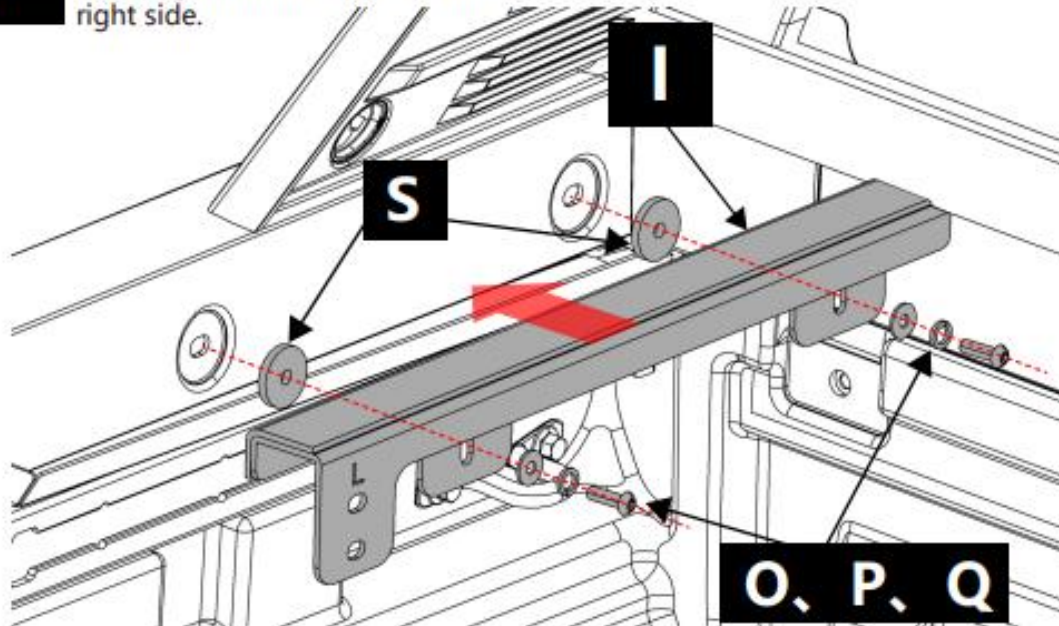

The bracket must be flush with the compartment

USE: **Z3**

S=5

Tips: The front bracket screws can be tightened directly with a wrench at this stage, as it becomes difficult to tighten them further once the roller blind is lifted onto the truck.

Align the front bracket with the two original screw holes on the inner side of the compartment. Insert an (O) screw with a (Q) flat washer and a (P) spring washer through the (S) bracket spacer and (I) front bracket, then install it onto the compartment. Finally, tighten securely with a (Z3) hex wrench. Repeat the same procedure on the right side.

31 Assemble the middle bracket, as shown in the picture, same as the right side.

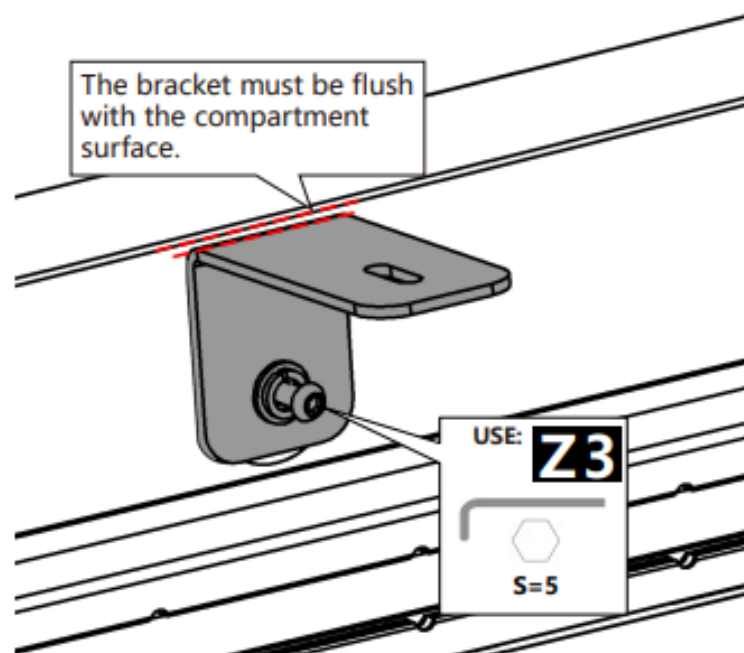
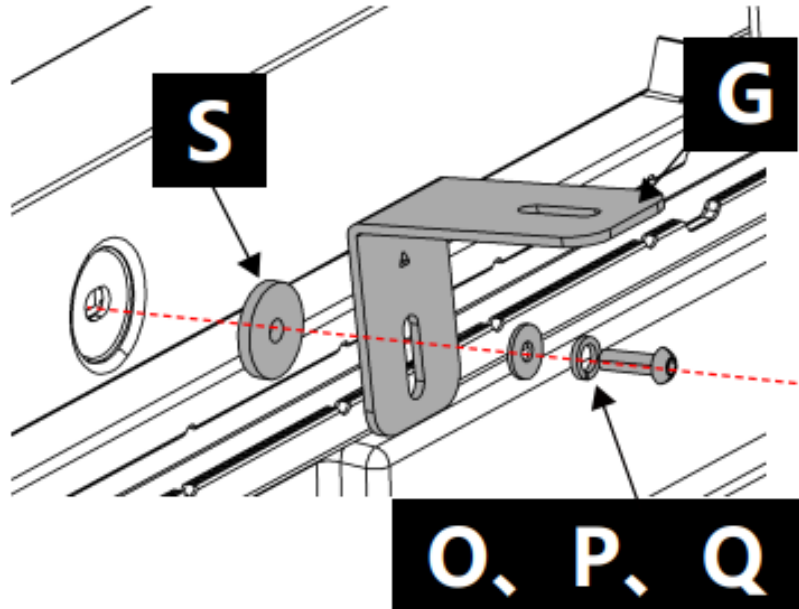

Align the center bracket with the original vehicle screw holes. Secure it to the compartment by passing an (O) screw with a (Q) flat washer and a (P) spring washer through the (S) bracket spacer and (G) center bracket. Tighten the screw with a (Z3) hex wrench. Same as the right side.

Tips: Do not fully tighten the screws at this stage to allow for subsequent adjustments.

32 Assemble the rear bracket, as shown in the picture, same as the right side.

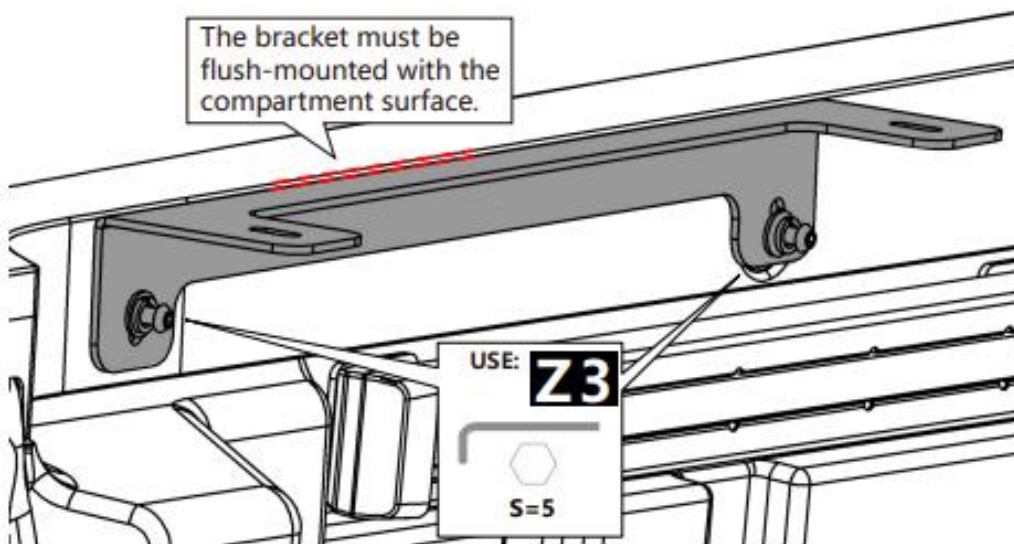
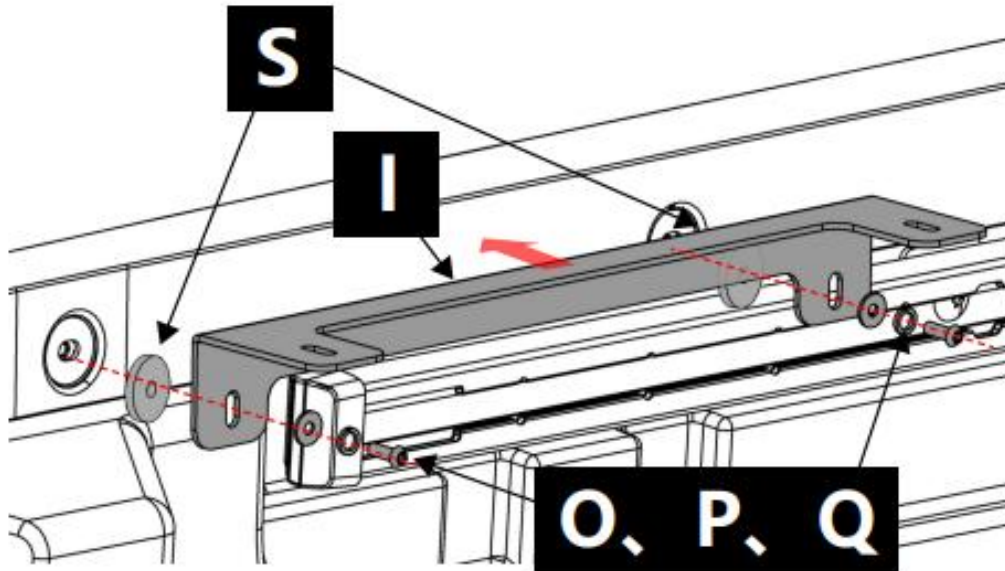

Align the rear bracket with the original vehicle screw holes. Secure it to the compartment by passing an (O) screw with a (Q) flat washer and a (P) spring washer through the (S) bracket spacer and (I) rear bracket. Tighten the screw with a (Z3) hex wrench. Same as the right side.

Tips: Do not fully tighten the screws to allow for future adjustments.

2.5 Product loading

33



Lift the product onto the carriage

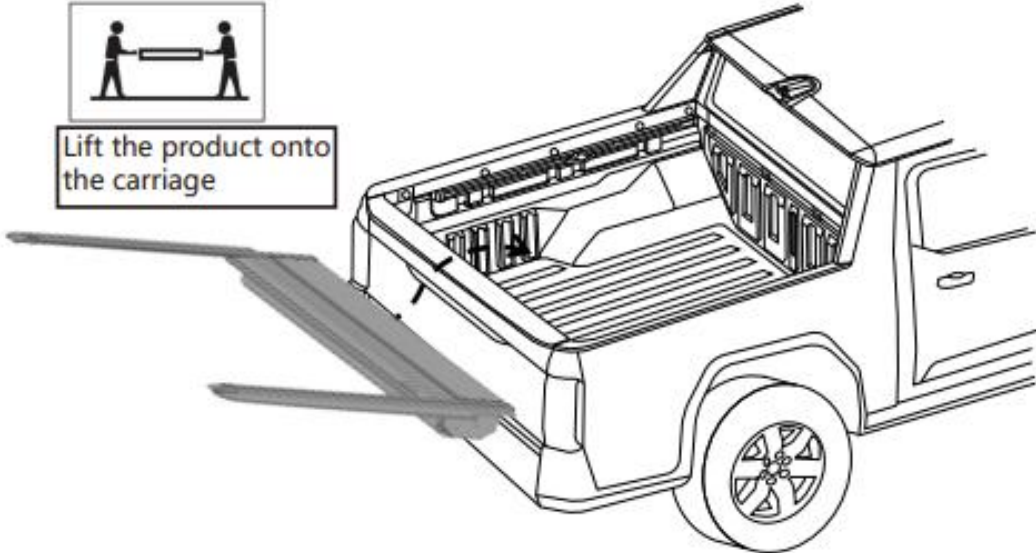

TIPS: Installation requires 2 people to lift the product onto the truck bed for safety of personnel and product. Please pay attention to avoid any scratch on vehicle and product surface.

34

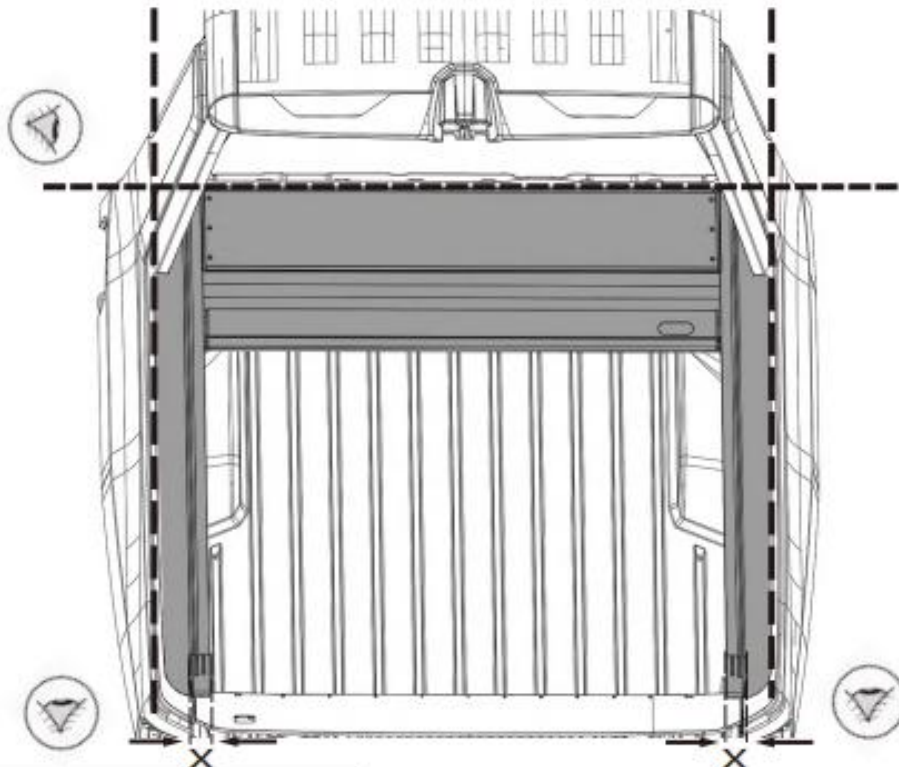

TIPS: If the end cap is not covered on the tailgate for 1-2cm, you need to move the cover backward slightly

Push the roller to the end; Keep the same distance on both sides.

35

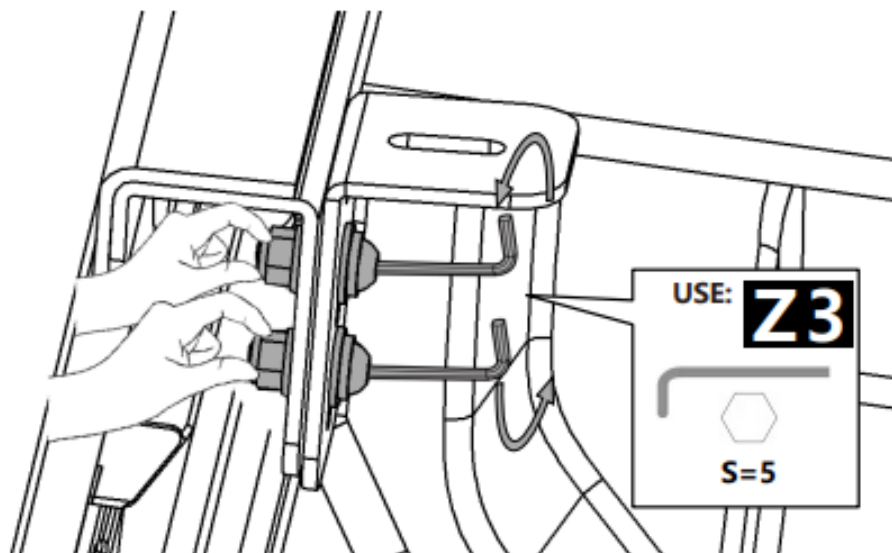
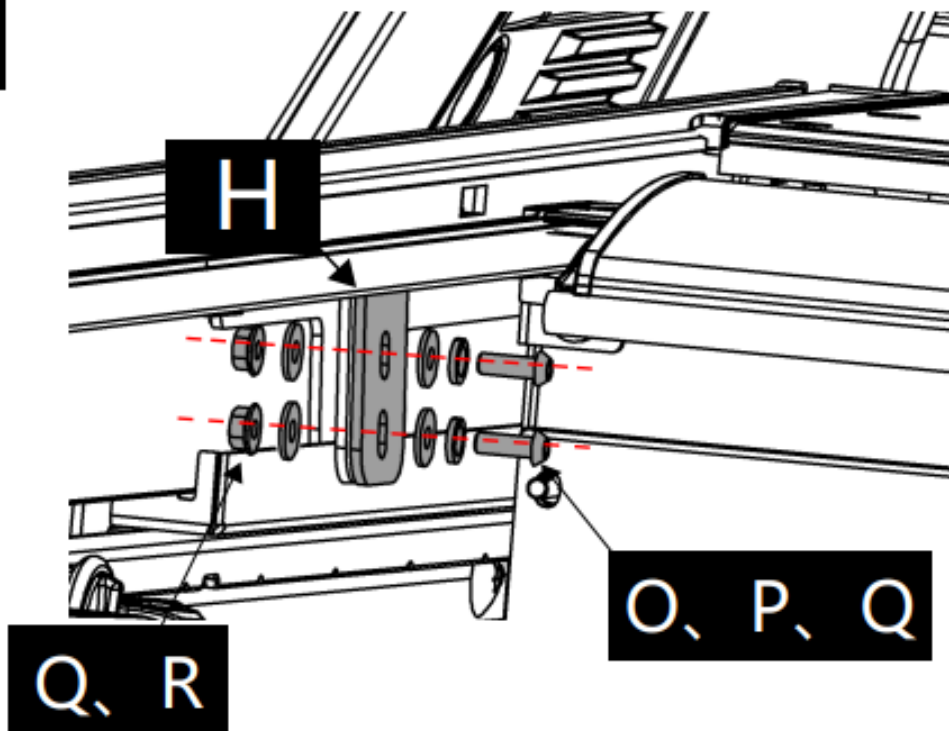

Install the small bracket onto the front bracket. Pass an (O) screw with a (Q) flat washer and a (P) spring washer through the (H) small bracket and the front bracket. Then assemble with an (R) nut and a (Q) flat washer. Manually hold the nut in place while tightening the screw with a (Z3) hex wrench to secure the small bracket to the front bracket. Repeat the same procedure on the right side.

Tips: Do not fully tighten the screws to allow for future adjustments.

36

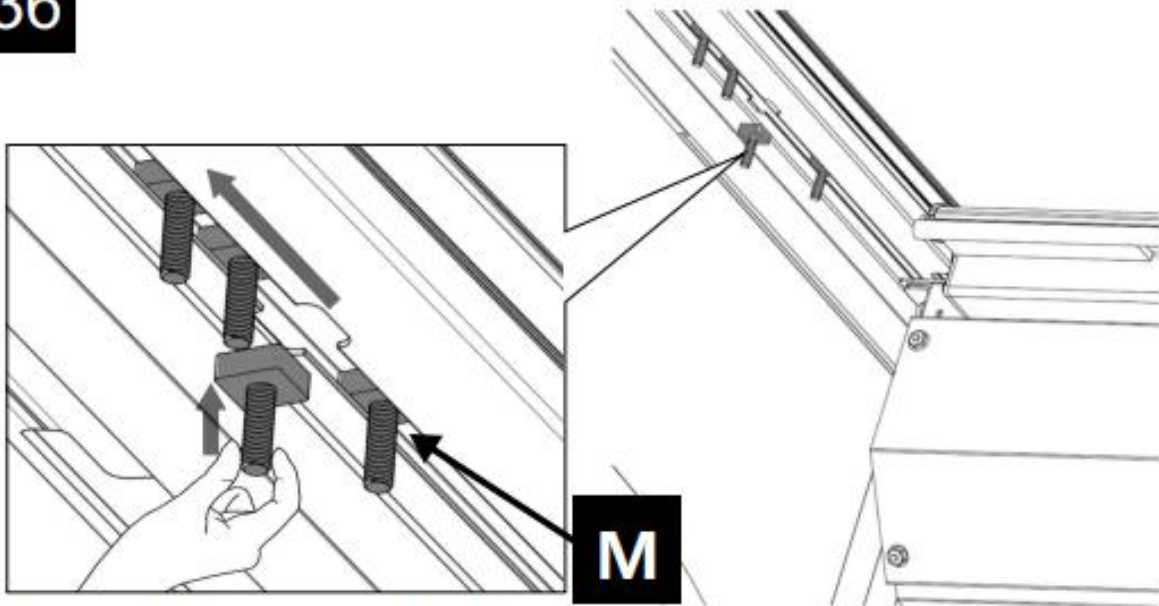

Place the (M) square screws into the sliding channel under the side rail. Use four pieces per side (half of the total quantity).

37

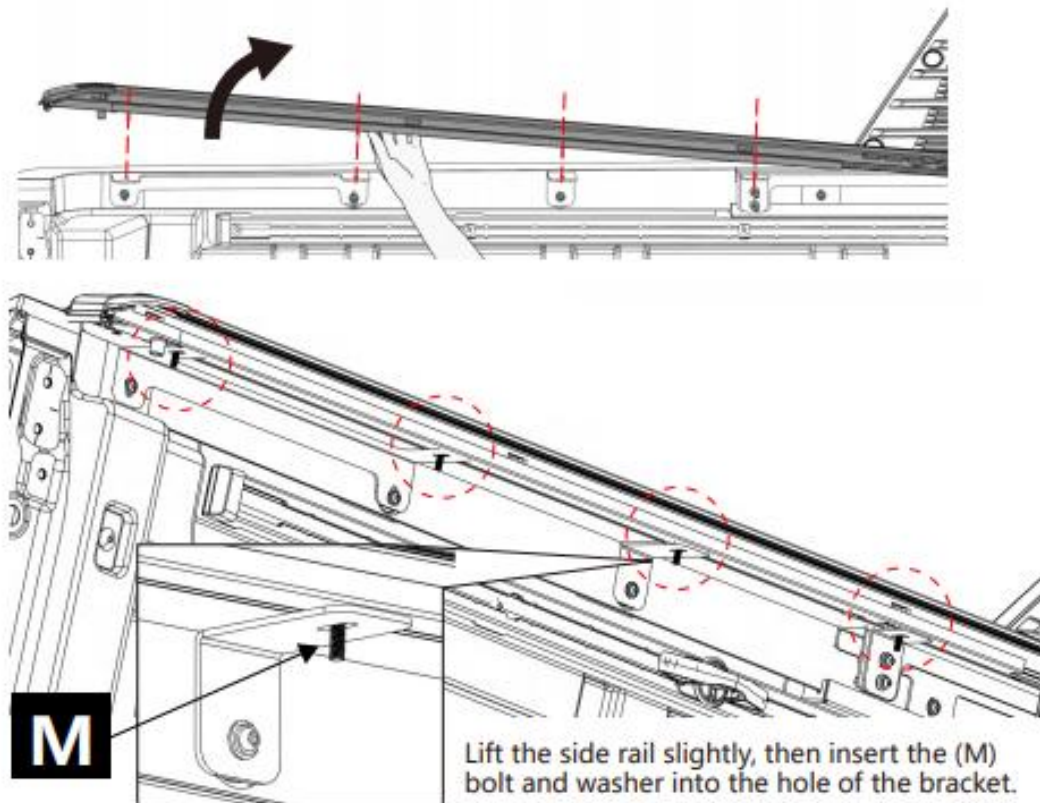

Lift the side rail slightly, then insert the (M) bolt and washer into the hole of the bracket.

38

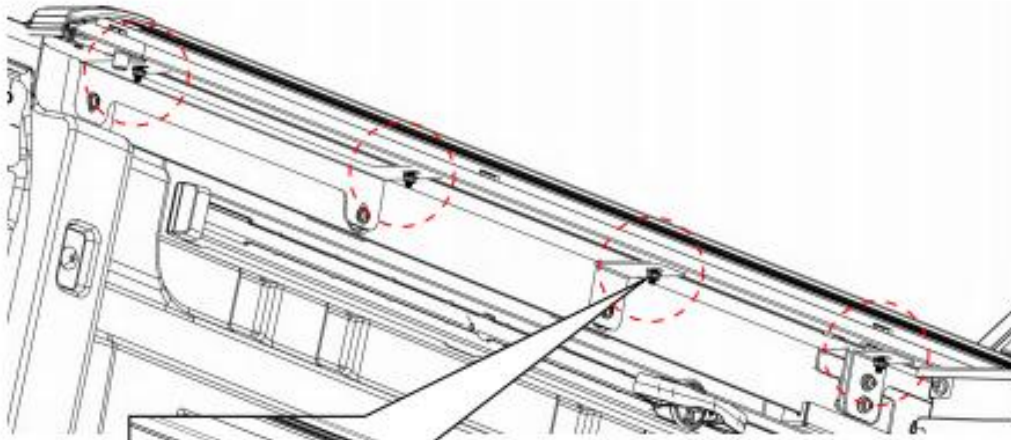

N

Assemble the (N) nut with the (M) bolt and washer. Hand-tighten only; do not fully secure at this stage.

TIPS: Do not fully tighten; secure slightly to allow for adjustment of the side rail.

39

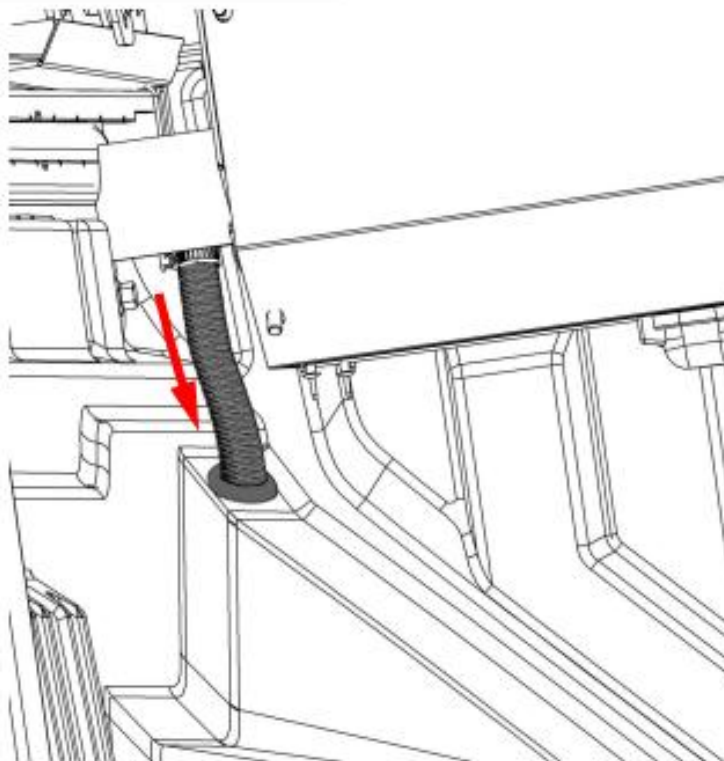

Insert the drain tube of the front splash shield through the rubber grommet to extend it outside the compartment. Same as the right side.

40

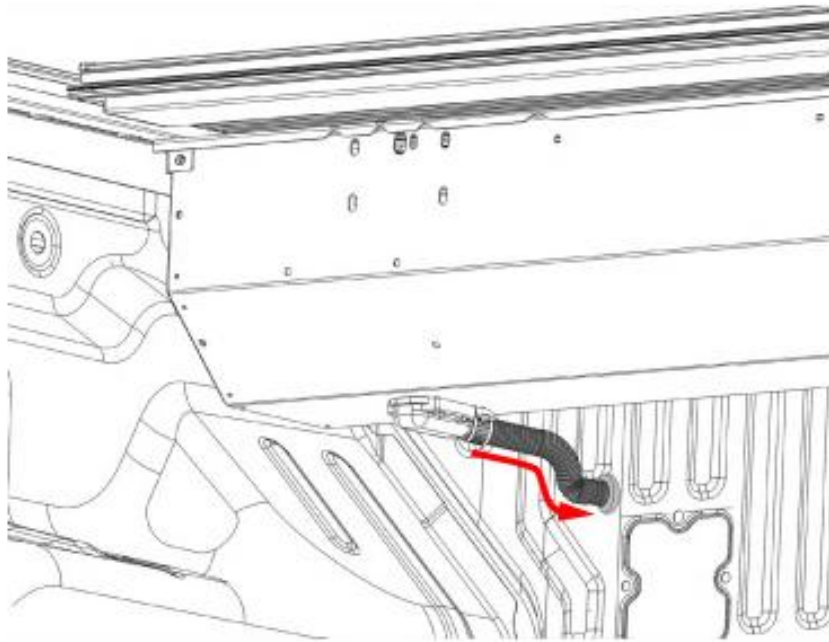

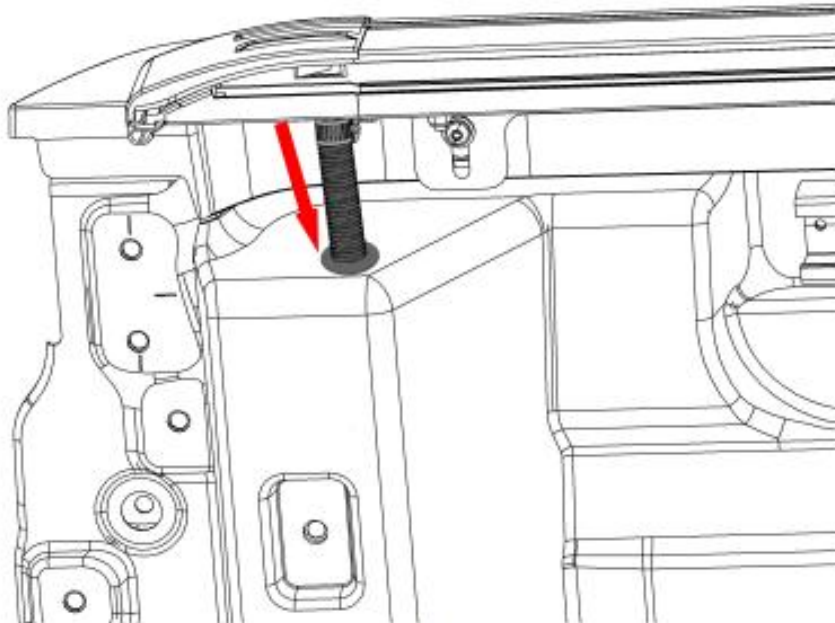

Insert the cabinet drain tube through the rubber grommet to extend it outside the compartment. Same as the right side.

41

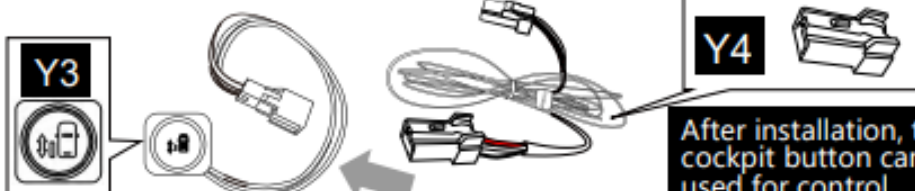

Insert the front drain tubes of the left and right side rails through the rubber grommets to extend them outside the compartment.

2.6 Wiring	
Necessary accessories for installation	<p>Power Cord (Gray)</p>  <p>Y1</p> <p>After installation, you can use the remote control key and app to control</p>
Optional installation of accessories	<p>Original car remote control key signal line (yellow)</p>  <p>Y2</p> <p>After installation can use the original remote key control</p>
	 <p>Y3</p> <p>Y4</p> <p>After installation, the cockpit button can be used for control</p>

1. Disaggregation diagram of necessity installation

42

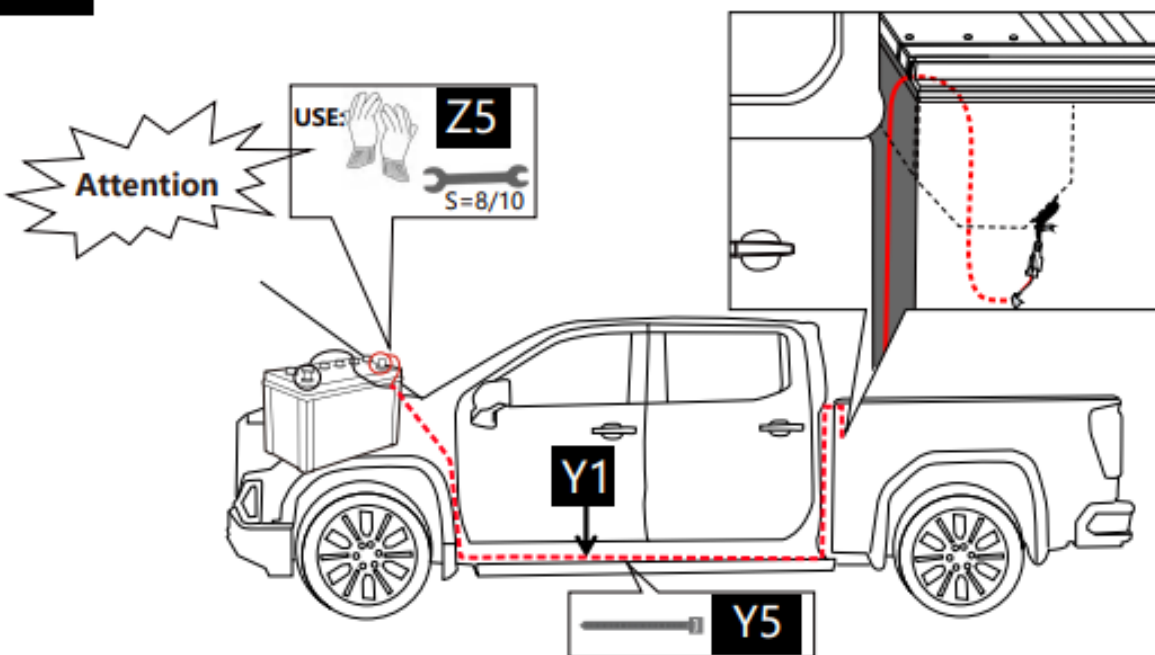

Wear the insulating gloves and open the hood. Loosen the bolts at the positive and negative pole of the original vehicle battery, and install the harness (Y1) in the corresponding position of the battery; Tighten the bolts. Route the rest of the harness from the bottom of the car to the trunk bed (fix the harness with (Y5) cable ties) and pull it out through the hole of drain tube. Connect harness (Y1) (in gray color) with roller gray interface (M1A). Harness route need to avoid exhaust pipes, moving parts, vulnerable parts etc., thus to protect the vehicle as well as avoid harness damage.

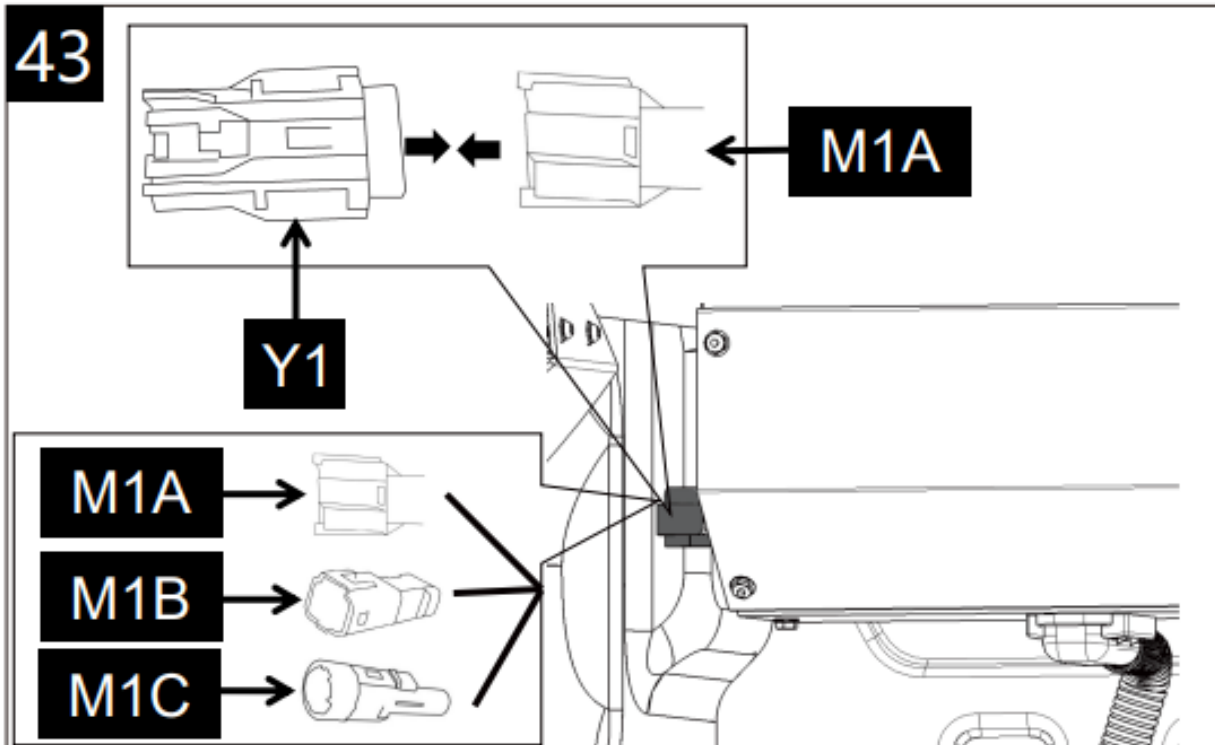

TIPS: There are three kinds of wire harness interface, different shapes, pay attention to distinguish.

Find the gray interface at the position shown in the figure. Connect harness Y1 (in gray color) with roller gray interface M1A.

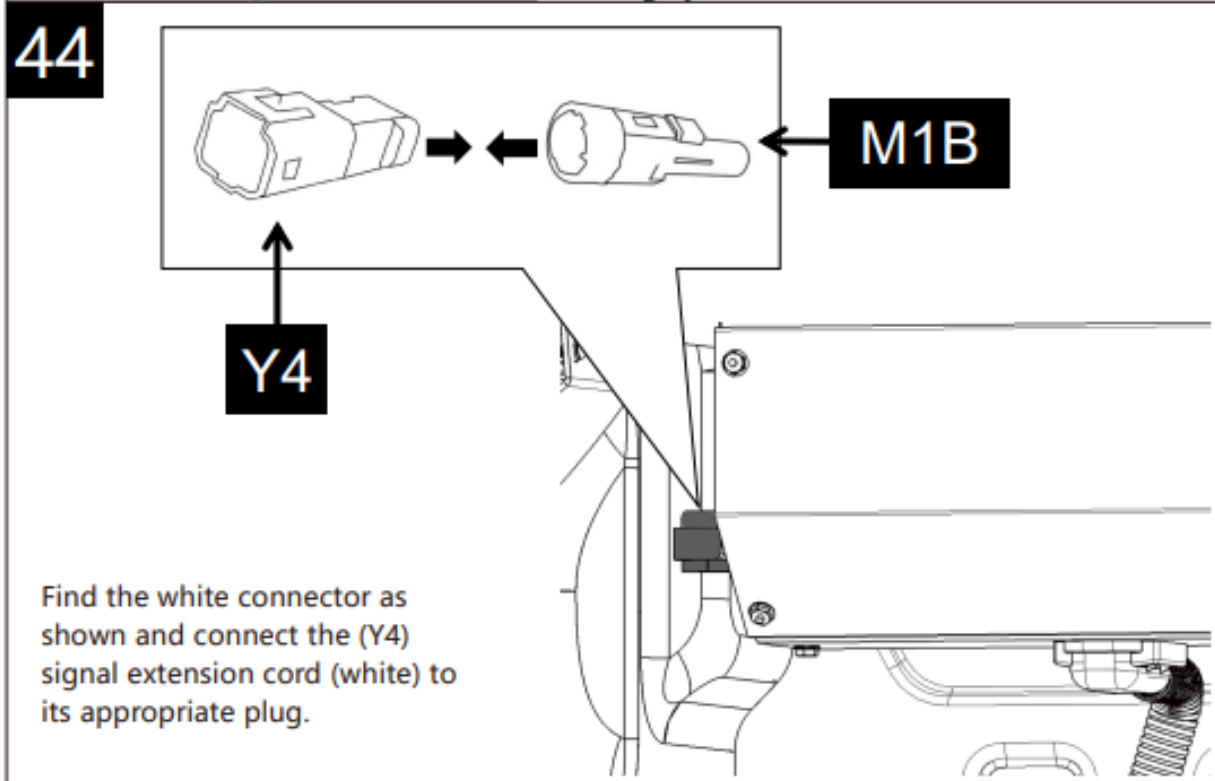

45

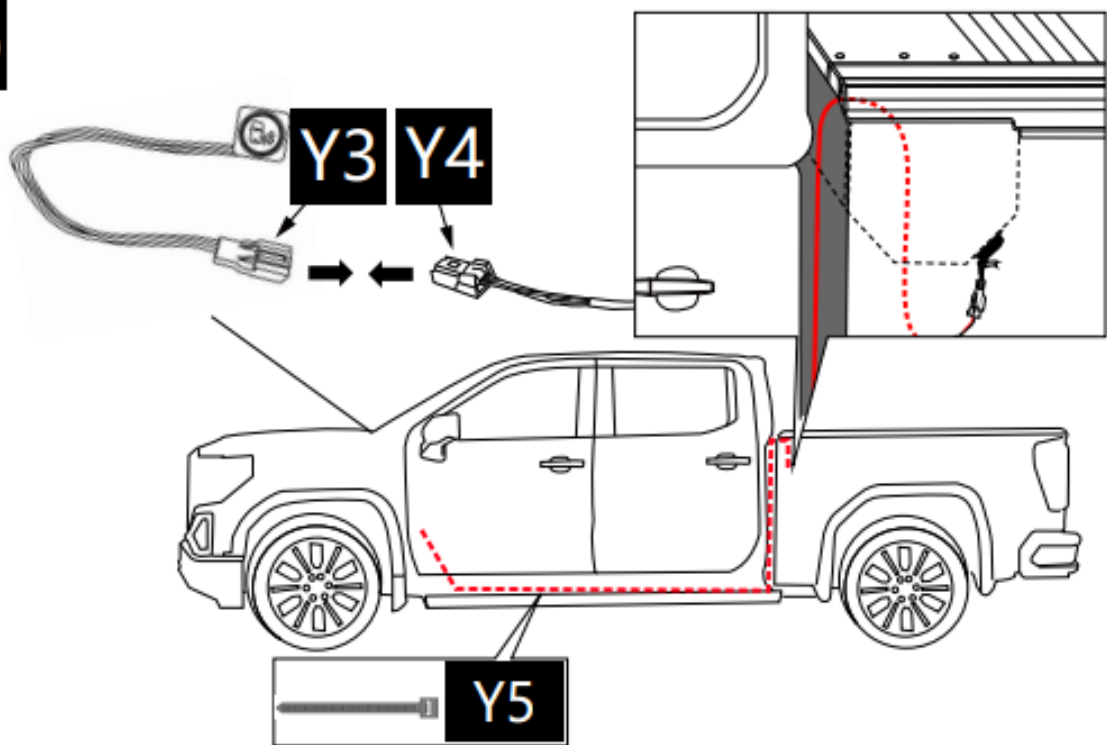

Connect the accessory Y3 cockpit button wire (white) to the accessory Y4 signal extension wire (white) and pull it to the driver's seat through the hole in the picture (secure the harness with the accessory Y5 cable tie). The wiring harness route needs to avoid the exhaust pipe, moving parts, vulnerable parts, etc., so as to protect the vehicle and avoid wiring harness damage.

46

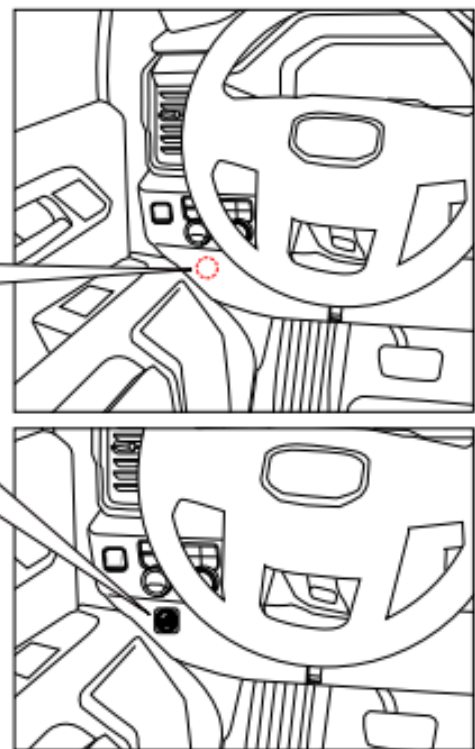
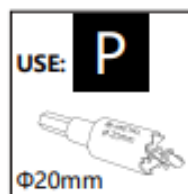

It can be installed on the blank position of the multi-function button in the driving position, and the wiring harness can be hidden in the trim panel.

Very important note: a $\Phi 20\text{MM}$ drill bit can be used after drilling and installation.



1: this option is not required. You can control the truck lid with an app or remote key without this button.
2: the installation position of the front button as shown, can also be placed in other positions, installation position can not be placed in front of the knee, to avoid the knee to touch the button operation.
3: This button for the cab button, no waterproof function, please do not contact with water, may cause short circuit.



47

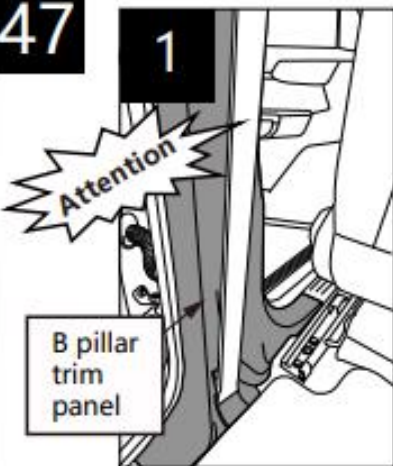

Open the driver's side B-pillar trim panel with wire harness clips such as (Figure 1, Figure 2).

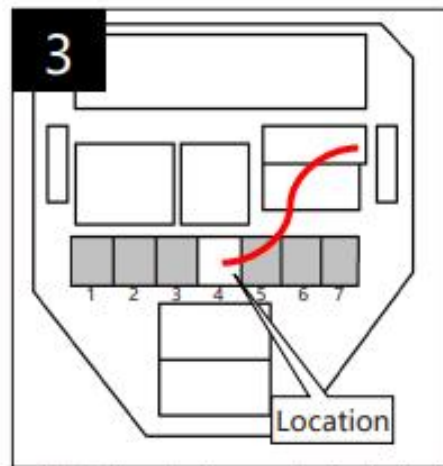

Find the wire harness in the hole shown in Figure 3. Use the wire clip to cut the original wire harness and connect the (N2-RRB-original signal wire (Yellow Line))

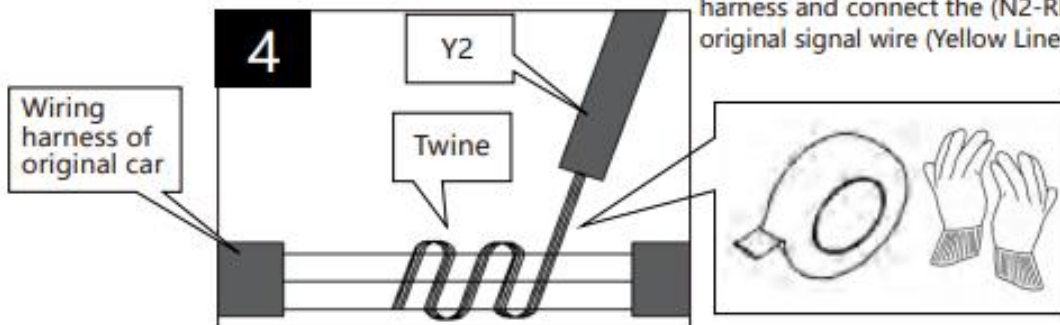

The connection method is as follows (fig. 4) : wear insulating gloves, use scissors or blades to cut to the bare metal part of the original car wiring harness, and wrap the wiring harness of (Y2) around the original car wiring harness, finally, the bare metal part can be tightly wrapped by electrician tape. The path as shown in Fig. 37(the harness can be secured by fitting (Y5) Tie-in) pulls the harness out of the hole in the compartment's drainage movable plate. Pay attention to the wiring harness path to avoid the engine, steering, exhaust pipe, moving parts, vulnerable parts, such as high temperature, moving parts. Easy to cause damage to vehicles, wiring harness.

48

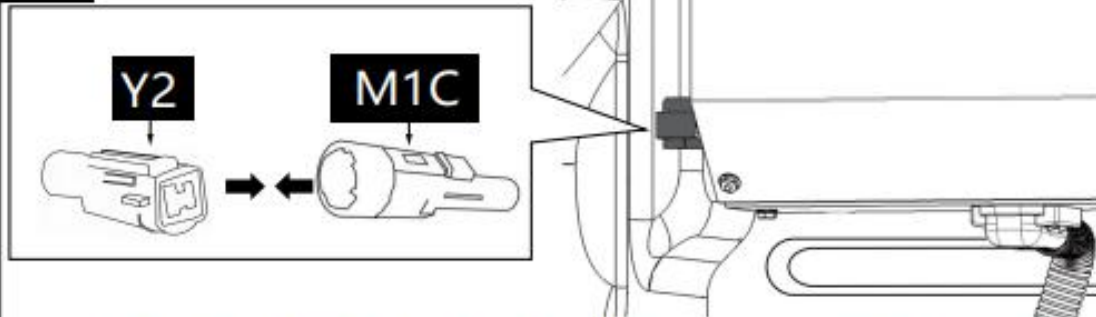

Find the M1C Black Connector in the location shown in the picture and connect the accessory Y2 original car remote control key signal wire (yellow) plug.

2.7 Adjust/check (Gage M4 or U)

49

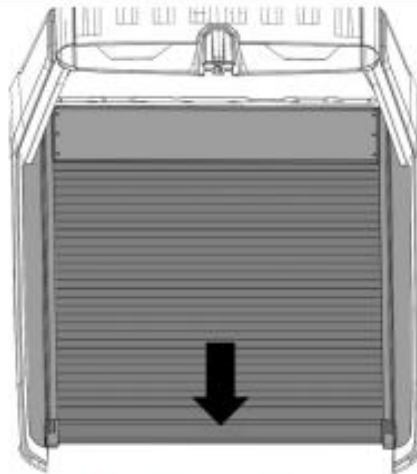
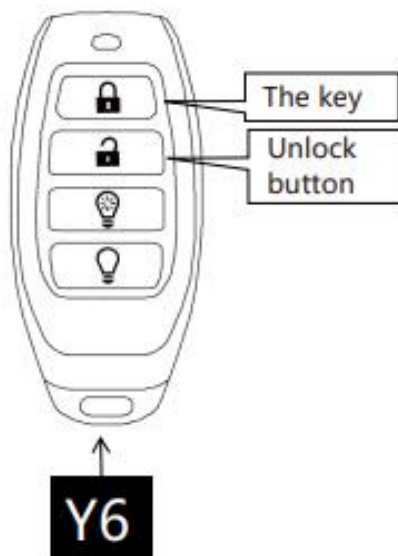

Use accessory Y6 electronic remote control to click the key/Open the lock button, test the normal operation of the shutter.

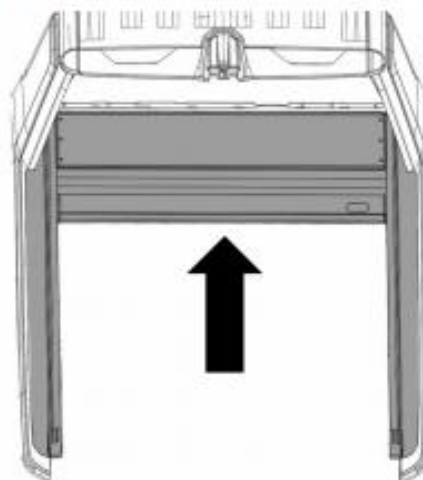

Retract the roller shutter by electric remote control.

Option 1: Accessories M4

50

Method 1: adjust the left and right side rod tail opening distance, as shown below, the two ends of the adjusting rod into the side rod chute, the left and right shaking gap is not more than 2 mm.

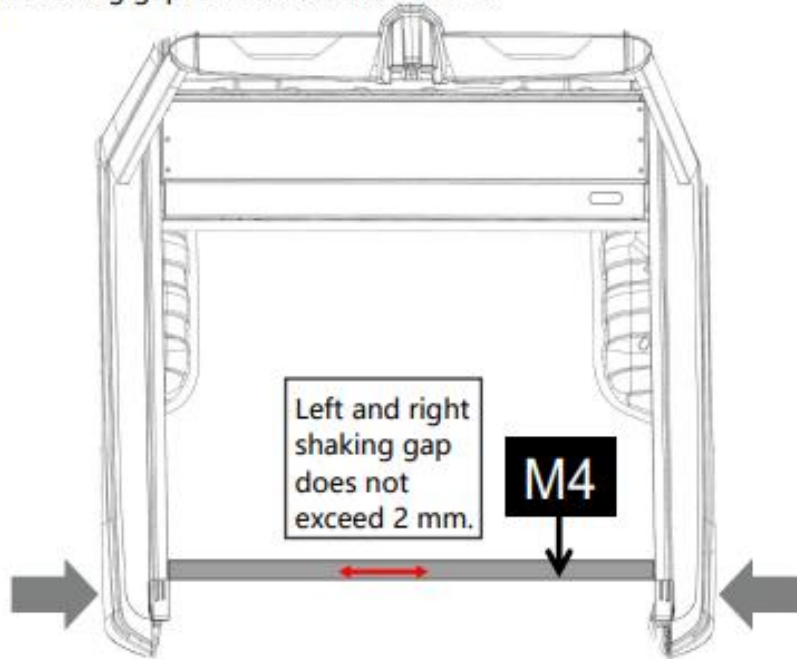

51

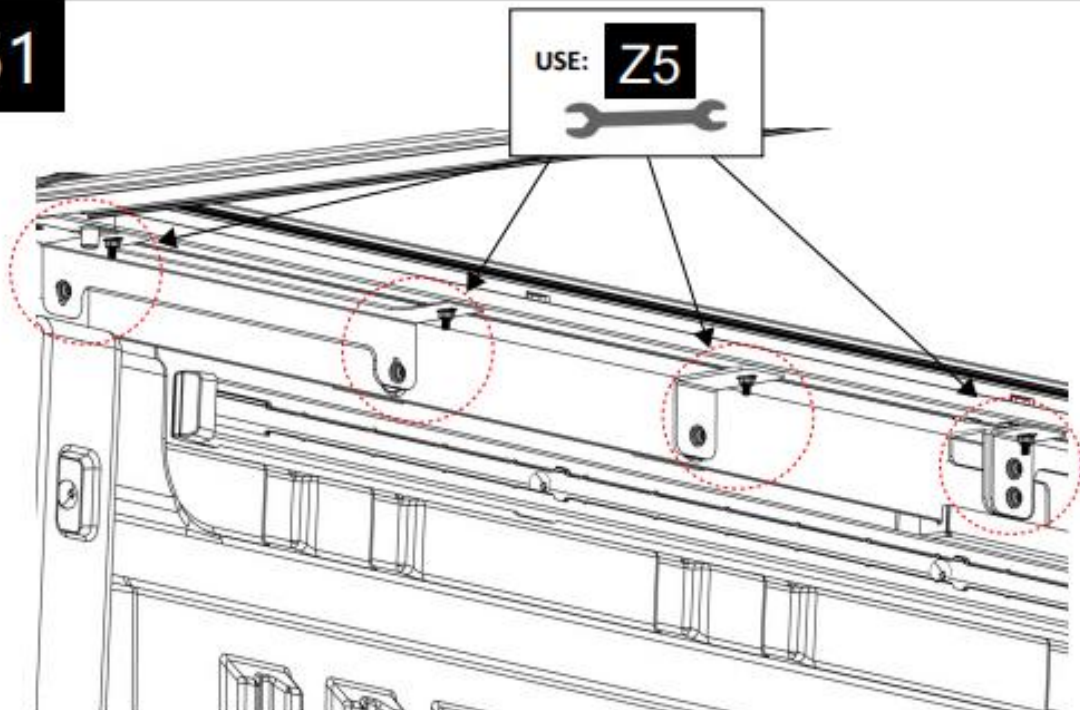

After tightening the bolts, remove the (m4) adjusting lever.

Tighten all bracket nuts using (Z5) wrenches.

Option 2: Accessories U

52

Method 2: close the shutter, and the fixture (U) placed in the tail between the door and the end of the side bar, 7-9 mm between the gap for the best state.

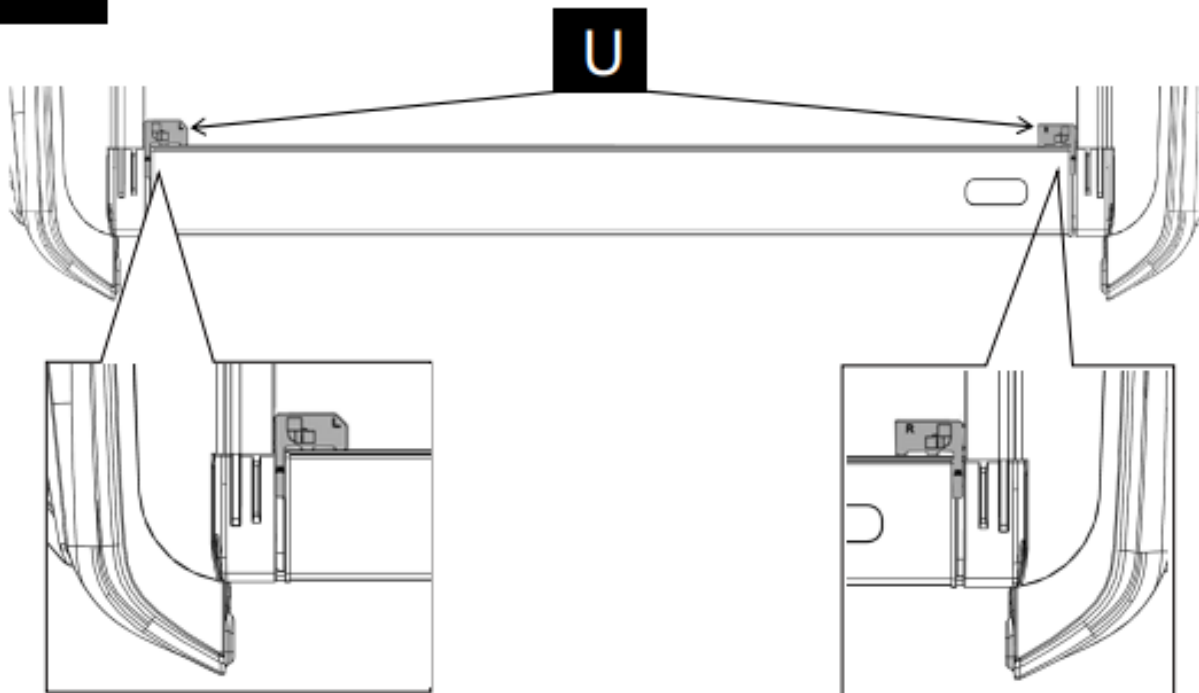

53

USE: **Z5**

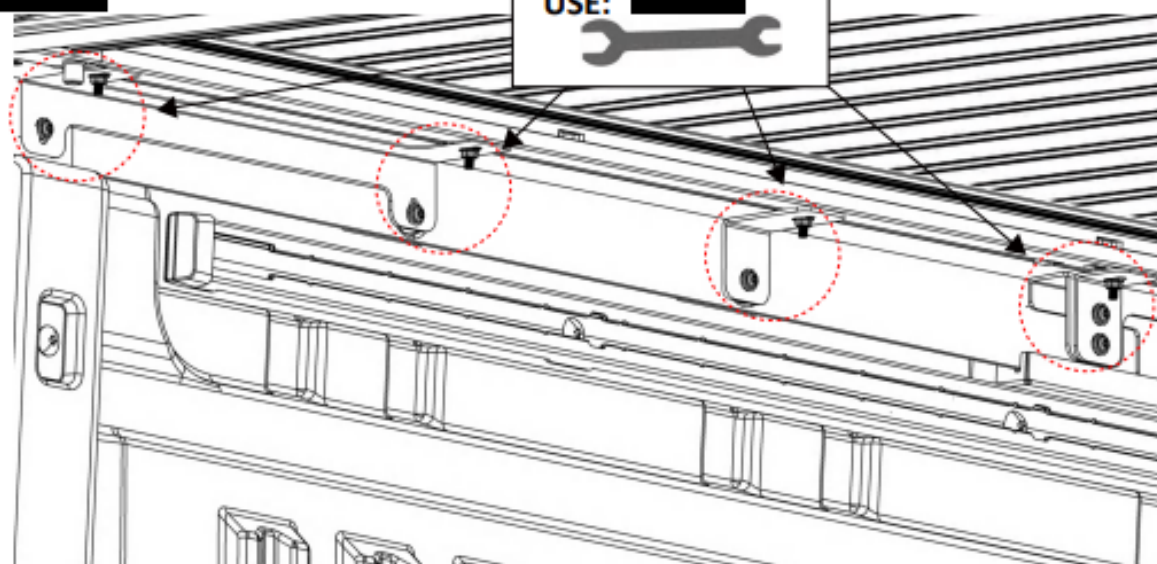

After securing the nuts to the rear brackets on both sides, remove the fixture (U) and open the shutters.

Tighten the rear bracket nuts on both sides with a (Z5) wrench, then open the shutter and tighten all bracket nuts.

Note: The above two adjustment methods should be selected according to the actual situation.



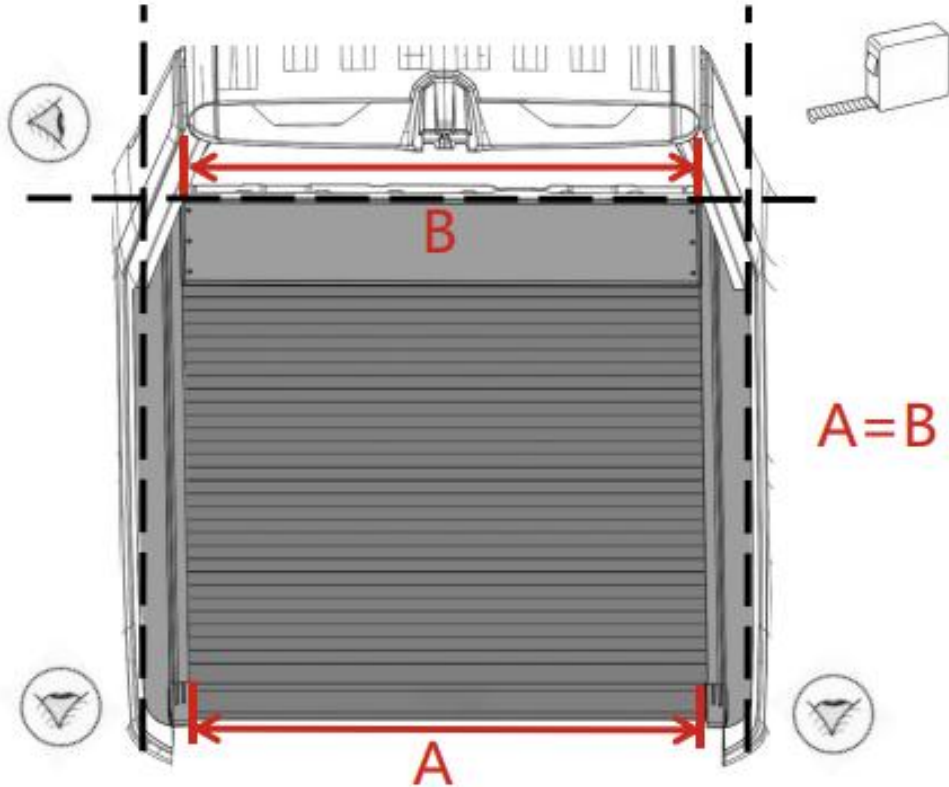

54



Make sure all the bolts are tightened, close the shutter, observe whether the product is parallel, can use a ruler to measure the gap between the front end and the back end of the product is consistent, the difference is within 2 mm is the best state.

3. Description

3.1 Introduction to remote control.

	Button	Button Name	Description
		Close	1. Press the button to close the cover if its under static mode. 2. Press the button to stop the cover if its under moving mode.
		Open	1. Press the button to open the cover if its under static mode. 2. Press the button to stop Light on the cover if its under moving mode.
		Light on	1. Press the button to light on if the light is off, and the brightness is restored to the previous brightness. 2. Press the button to switch to the next brightness level if the light is on(level 3 brightness in cycle switch) .
		Light off	Press the button to turn off the LED light.

Replace the battery with the remote control:

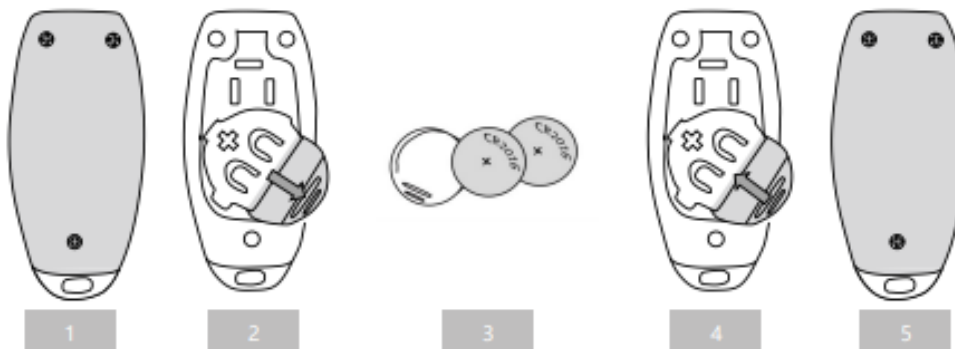

Remote Key Extras

Key combination function	Sound of successful operation	Operation	Remarks
Code Match	1 long and 1 short	Press both Open & Close button at the same time.	The operation is effective within 5s after power-on.
Open/close the cover in place	1 Long	Press Light Off button 3 times.	No time limits for this operation, but the 3 times press must be continuous.
Initialize the cover position	1 long 2 short	Press both Light On & Off button at the same time twice in 3S.	This operation if effective only when the cover is completely closed.
Adjust anti-pinch strength	1 long 3 short	Press both Close & Light Off button at the same time twice.	3 strength levels switch in circle (the default setting is medium strength).
Adjust the running speed	1 long 4 short	Press both Open & Light On button at the same time twice.	3 strength levels switch in circle (the default setting is medium strength).

3.2 Key Fob Control

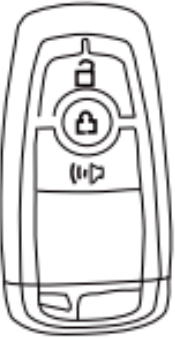
	Operation	Cover State	Remarks
	Press Unlock 3-5 times continuous	Cover open	Press 3 to 5 times in 2 seconds to be effective, more than invalid.
	Then Press Unlock 1 time	Cover stop	This operation is only effective under cover moving status (press Unlock 1 time to stop the cover); if not under moving status, this operation is invalid.
	Press Unlock twice	Light on	When the cover is under closed status, press Unlock twice in 2 seconds, then the light on (time-out invalid).

3.3 Front Button Control

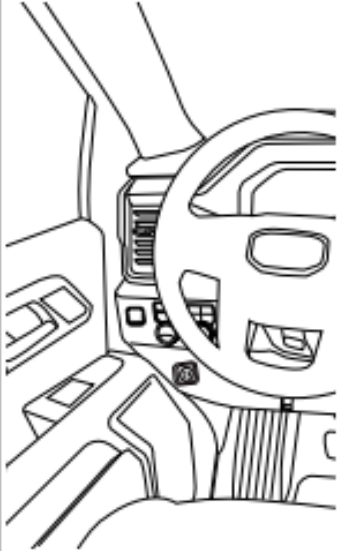
	In order to facilitate user's operation, we offer an extra option with button control near driver's seat, so the user can easily control roller.		
	Operation	Function	Remarks
	Long press (about 1s)	Cover open	This operation is only effective when the cover is under closed status, after the operation of the cover to open, and in the open button light has been lit.
	Press again	Cover stop	1. When the cover is under moving status, press again to stop. 2. When the cover is stopped and under an open state, press again to close. 3. When the cover is under closed status, the operation is invalid.
Short press	No react	To avoid mis-operation, if the cover is not activated by long press, short press is considered by the system as mis-operation, do not react.	



4. Maintenance and repair

4.1 Solutions to common problems.



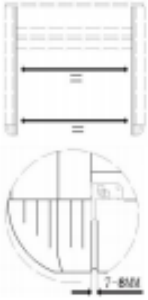

Alarm sound for abnormal operation of roller shutters

Abnormal sound	Reason	Remarks
2 short	Over current in motor operation	Operating resistance is too big. Mainly because run into obstacles, or not on time maintenance.
3 short	Time out for motor operation	Cover one-way running time for more than 15S.
4 short	No Hall signal detected	Motor or controller failure, or not well connected with the plug.

Rolling shutter failure analysis:

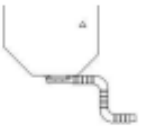
Number	Common fault phenomenon	Analysis	Pics	Solutions
1	Abnormal sound-2 short	1.Side bars are installed inward or outward and not placed parallel. 2.Big resistance leads to non-smooth operation. 3.Side bars deform due to heavy load for sport bar/ladder rack etc.		<ol style="list-style-type: none"> 1. Use the installation gauges. 2. Adjust the side bar installation to make sure the front and rear distance are the same. 3. Pull the roller out completely and measure the gap between tailgate bar and side bar ends, gap between 7-8mm is the best. 4. Check if the side bar is deformed by the pressure of other heavy load parts. 5. Adjust the brackets of side bar installation, to make sure the side bars are parallel to the roller.
2	Abnormal sound-4 short	No Hall signal detected.		<ol style="list-style-type: none"> 1. Unplug and replug the controller connector as well as the motor. 2. Replace the controller or motor.
3	The remote key can not control the cover	<ol style="list-style-type: none"> 1. The cover not power on. 2. Low battery in the remote key. 3. Unmatched code with controller. 		<ol style="list-style-type: none"> 1. Check if the LED light on controller is flashing to confirm power supply is okay. If no power, check if the positive fuse or roller burnt out. 2. Check if the indicator on remote key is obviously dimmed or no light when you press the button, then replace battery. 3. Do code match for the remotes.

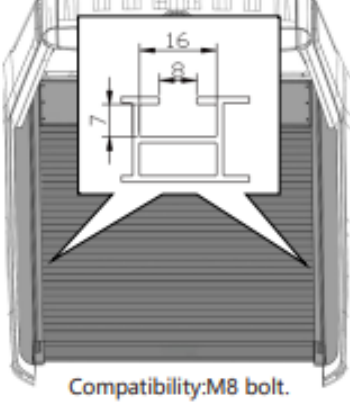
4.2 Rolling shutter failure analysis.

 Keep the drainpipe free from blockage.	 Clean the litter before use.	
 Clean and lubricate the canister every 6 months.	 Clean and lubricate the side bars every 3 months.	

5. Helpful Maintenance Hints

1. To assure quiet and smooth operation of your roller, please regularly clean and lubricate the rail tracks and canister. It is recommended every 3 months or 6,000 km, or when you use it in muddy water, desert, Gobi desert, etc. Please focus on cleaning the side rails and the spiral track inside the container which may have sand, sludge, gravel and other sundry inside. Please use the lubricants we offered or other brand silicone oil-type lubricants after cleaning, and increase the frequency of using lubricants based on actual situation. Avoid using petroleum-based product on rubber seals. Lighter oil spray lubes with PTFE (Teflon) seem to work the best when regularly wiped out and reapplied.

2. Avoid the thicker grease type because they tend to get sticky and gather a lot of dust and debris and then later dry out. Also Avoid the silicone dry lubes as they tend to cause squealing noise between the sliding components.

3. Please make sure the roller is in a stop status before cleaning/lubricating, to avoid causing extrusion or collision injury.

4. To clean the rail tracks and the spiral track inside the container, please apply the lubricant to a rag and wipe it inside of the rail tracks, along the underside of the sweep seal and the top of the wear strip. Repeat until the dust has been removed. You can also use a high-pressure water gun if necessary and then make sure all components have been lubricated. Please do not direct aiming the high-pressure water gun to the motor/ECU/connector when cleaning, and do some necessary waterproof protection for connectors/plugs.

5. To clean the canister, remove the rail stops, or vertical rails as required, and run the cover out far enough that you can get into the canister. Apply the lubricant to a rag and wipe the inside of the canister, including all components inside the canister. Ensure the Drain Tubes are clear of any debris or blockage. Reassembly the cover .

6. If you find that the brightness of the remote control signal indicator light is obviously weakened, or the button indicator light does not on, please replace the battery in time (battery model: CR2016).

7. To keep the roller in tip-top condition, we recommend washing it the same as caring for your truck finish. A lack of proper cleaning and maintenance can affect the operation of the product and reduce its life.

8. Do not attempt to drive with the tail panel in the partially open position.

9. Tonneau cover must be free of foreign material including snow and ice before opening panels.

10. Do not tow your vehicle from the rear with the tonneau on your truck.

11. Do not operate vehicle with objects on top of cover.

Failure to follow these cautions may result in severe damage and will void your warranty!



AUTOMOTIVE ACCESSORY
MANUFACTURE & DISTRIBUTION

AIRPLEX INDUSTRIES LTD
21 Saleyards Road, Otahuhu, Auckland 1062, New Zealand
PO Box 11286, Ellerslie, Auckland 1542 New Zealand
PH +64 (9) 276-9826 Fax +64 (9) 276-9836
info@airplex.co.nz www.airplex.co.nz

PLEASE READ INSTRUCTIONS COMPLETELY BEFORE SET UP

AIRPLEX ELECTRIC ROLLING LID **PHONE APP SET UP GUIDE**

Important Note: Please do not disclose your password for the Rolling lid app.

1. BRIEF INTRODUCTION

This paper introduces the detailed use and precautions of Electric Retractable Tonneau Cover Smartphone APP control.

2. OPERATION INSTRUCTION

2.1 Login the program

- 1) For IOS system Smartphone, please search 'Smartctr' in APP Store to download.
- 2) For Android system Smartphone. Please scan the following QR code with browser and download.



- 3) Enter the APP, click 'Start scan' to search device start with 'WTJL'.

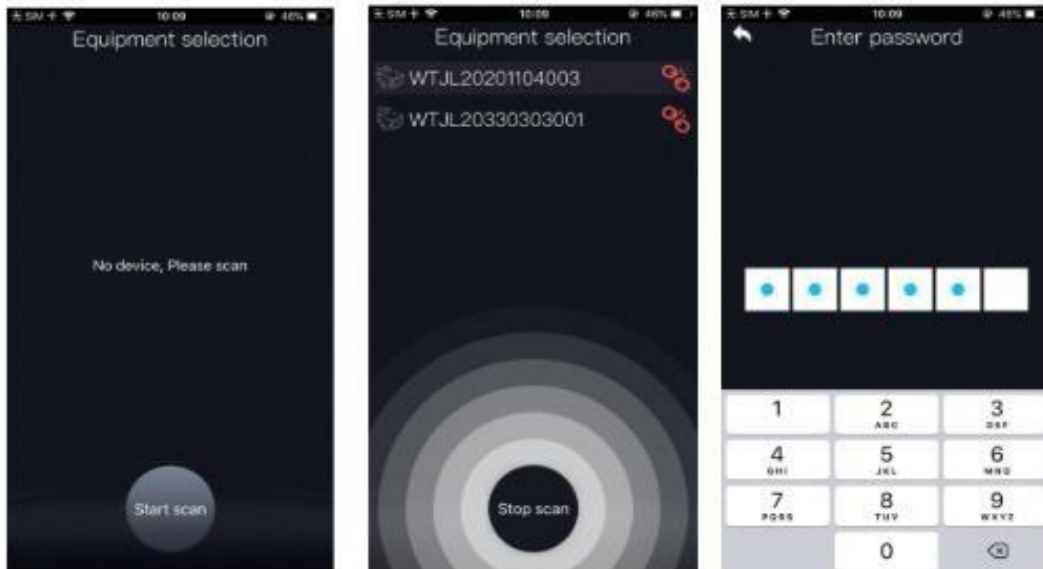

- 4) Click the effective scanned device, input initial password 123456 to enter.
[Please change the password after login, do not disclose the password to anyone, so as not to cause vehicle security problems!]

2.2 Program Main Interface

Program Main Interface Introduction



- A: Click to open the "closed" or "not fully Open" Tonneau Cover; If the Tonneau Cover is already fully open, then it will keep still.
- B: Click to close the Tonneau Cover; If the Tonneau Cover is already closed, then it will keep still.
- C: Click to turn on the light with previous brightness level if it was "off" status; If it was already "on" status, then the light brightness shall cycle among 25%, 50%, 100% after every click.
- D: Turn off the LED light.
- E: Indicate the LED light status. Red color indicates light on, Grey color indicates light off.
- F: Click to enter the device info interface.
- G: Click to enter the device setting interface.
- H: Change Password

Note:

The following pictures will display the current position of Tonneau Cover in real time.



2.3 APP Program Info Interface

Program Info Interface Introduction

The interface mainly records and displays the basic information and usage records of the device.



AUTOMOTIVE ACCESSORY
MANUFACTURE & DISTRIBUTION

AIRPLEX INDUSTRIES LTD
21 Saleyards Road, Otahuhu, Auckland 1062, New Zealand
PO Box 11286, Ellerslie, Auckland 1542 New Zealand
PH +64 (9) 276-9826 Fax +64 (9) 276-9836
info@airplex.co.nz www.airplex.co.nz



2.4 APP Program Setting Interface

Program Info Interface Introduction

After modifying the configuration, please click the bottom "Update Settings" to make the settings effective.

Note: Users can only modify contents in the following blue box, other items can't be modified

randomly, or may cause the abnormality of the device.



Anti-pinch strength: [S(small), M(medium), L(large)]. By setting this item to adjust the sensitivity of starting and stopping protection when touching obstacles during Tonneau Cover Operation.

Anti-pinch strength	Description	Remark
S(small)	High sensitivity	
M(medium)	Medium sensitivity	Factory Default Settings
L(large)	Low sensitivity	

If the Tonneau Cover has been used for a long time without regular maintenance in time, or with improperly installation, the operation resistance may increase and trigger the "Anti-pinch protection", so the Tonneau Cover may stop during operation. Then you can reduce the sensitivity of "Anti-pinch protection" by setting this "Anti-pinch strength" for a temporary solution to this problem.

Note: This is recommended only as a temporary solution to solve the problem. To ensure the Tonneau Cover works in good condition, it must be installed correctly and maintained timely. Do not long-term use it after reducing the sensitivity.



AUTOMOTIVE ACCESSORY
MANUFACTURE & DISTRIBUTION

AIRPLEX INDUSTRIES LTD
21 Saleyards Road, Otahuhu, Auckland 1062, New Zealand
PO Box 11286, Ellerslie, Auckland 1542 New Zealand
PH +64 (9) 276-9826 Fax +64 (9) 276-9836
info@airplex.co.nz www.airplex.co.nz

Running Speed: [H(high), M(medium), L(low)]. By setting this item to change the running speed of Tonneau Cover.

Running Speed	Description	Remark
L(low)	Low speed	Generally about 12 seconds to finish Open or Close operation
M(medium)	Medium speed	Factory Default Settings, 10 seconds to finish Open or Close operation
H(high)	High speed	8 seconds to finish Open or Close operation

In addition to affecting the completion time of Open or Close Tonneau Cover operation, the Running Speed is more slower, the smoother the Tonneau Cover runs, and also less noise during running. Thus we recommend customers choosing slower Running Speed.

Change password: Change the login password through this item.

Click "Change password", it will show the following interface.

The password is 6 Arabic digits.

Note: for the safety of your vehicle, avoid using same six numbers, or consecutive numbers.



After entering exactly the same 6 numbers in the "new password" and "confirm password", click "ok" to complete the password change.