

# CL100 MorticeLock™

## Fitting Instructions

**NOTE: Please read instructions before drilling any holes or marking out hole centres.**

The CL100 Mortice Case is designed to fit the following door furniture:

- A. CL100 LAVILOCK
- B. CL100 LEVER
- C. CL100 FLUSHTURN
- D. CL100 DIGILOCK

When installing handles, highlight the fixing arrangement that is required on the template.

Mark both sides of the door using the template (flip template over to mark other side).

**DO NOT drill right through the door** as alignment issues will occur. Only drill to centre.

If installing a locking option, highlight the option required and the correct side of the door to be drilled on the template.

**There are five stages to fitting the Mortice Case:**

**Stage 1:** Mark drilling positions for lock case.

**Stage 2:** Mark drilling positions for door furniture to be installed

**Stage 3:** Prepare door by morticing and drilling holes.

**Stage 4:** Fit lock, door furniture and cylinder.

**Stage 5:** Fit striker.

### Stage 1 - Mark Drilling Positions for Lock Case

1. Mark chosen height of lock on face of door.  
Height is normally measured to centre of square spindle (**Hole 9**). When no spindle is required, measure to centre of Euro Cylinder (**Hole 10**).
2. Mark 'Height Line' at top of template 57.5mm (2-9/32") above **Hole 9** or 121.5mm (4-25/32") above **Hole 10** on front edge and both faces of door.
3. Make a vertical centre line on front edge of door.

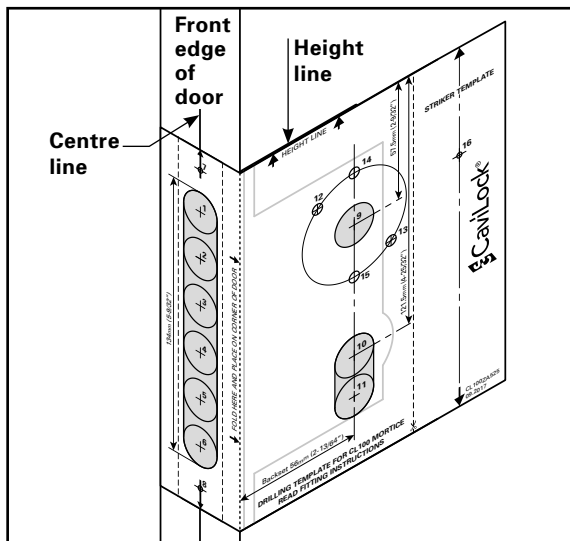

4. Align top edge of template with height line and arrows to vertical centre line.
5. Mark universal hole positions (**Holes 1-8**) for lock case using a sharp nail or pencil.

#### Universal Hole Positions

Hole #	Hole Diameter		Depth	
1 - 6	19mm	3/4"	77mm	3"
7 & 8	2.5mm	3/32"	25mm	1"

### Stage 2 - Mark Drilling Positions for Door Furniture

*Refer to drilling options table below that relates to door furniture being fitted.*

1. Highlight correct drilling options required for handle and locking options being installed.
2. Use a sharp nail or pencil to mark required hole centres.

#### A: LAVILOCK

Hole #	Hole Diameter	Depth	Door Side
9 - 11	19mm	3/4"	To Centre of Door Both
<b>CS Supplied Handles with 45° Angle Fixing</b>			
12 & 13	5mm	3/16"	To Centre of Door Both
<b>Customer Supplied Handles with Vertical Fixing</b>			
14 & 15	5mm	3/16"	To Centre of Door Both

#### B: LEVER

Hole #	Hole Diameter	Depth	Door Side
9	19mm	3/4"	To Centre of Door Both
<b>Locking Option - Double Cylinder</b>			
10 & 11	19mm	3/4"	To Centre of Door Both
<b>Locking Option - Half Cylinder</b>			
10 & 11	19mm	3/4"	To Centre of Door Optional
<b>CS Supplied Handles with 45° Angle Fixing</b>			
12 & 13	5mm	3/16"	To Centre of Door Both
<b>Customer Supplied Handles with Vertical Fixing</b>			
14 & 15	5mm	3/16"	To Centre of Door Both

#### C: FLUSH TURN

Hole #	Hole Diameter	Depth	Door Side
9	65mm	2-9/16"	To Centre of Door Both
<b>Locking Option - Double Cylinder</b>			
10 & 11	19mm	3/4"	To Centre of Door Both
<b>Locking Option - Half Cylinder</b>			
10 & 11	19mm	3/4"	To Centre of Door Optional

D: DIGILOCK				
Hole #	Hole Diameter		Depth	Door Side
9	19mm	3/4"	To Centre of Door	Both
Locking Option - Double Cylinder				
10 & 11	19mm	3/4"	To Centre of Door	Both
Locking Option - Half Cylinder				
10 & 11	19mm	3/4"	To Centre of Door	Optional
Holes not on template	Hole Diameter	Position (to centre of door)		Door Side
17	13mm	1/2"	22.2mm (7/8") below Hole 9	Both
18	13mm	1/2"	13mm (1/2") above Hole 9	Both

### Stage 3 - Mortise & Drill Holes

3  
STAGE

#### DO NOT drill right through the door.

Alignment issues will occur. Drill to centre on both sides for through holes. Check Stage 2 chart for hole depth.

1. Drill **Holes 1-6**. Make sure drilled holes are straight and level.
2. Chisel out remaining wood between holes indicated in shaded area on template to create a slot.  
Note: Maximum slot length not to exceed 134mm (5-9/32").
3. Drill **Holes 7 and 8**.
4. Remove face plate from lock case and temporarily screw lock case in place. Mark around outside edge of inner forend then remove lock.
5. Router out marked area to a depth of 7mm (9/32").  
**Important:** Recess of front section must be routered flat and even. Long term damage will occur if not done correctly.
6. Drill **Hole 9**.
7. Drill **Holes 10 and 11** (if required for locking options).
8. Remove remaining wood from oval shaped slot between **Holes 10 and 11**.
9. Drill holes for fixing handles using marks from **Stage 2**.

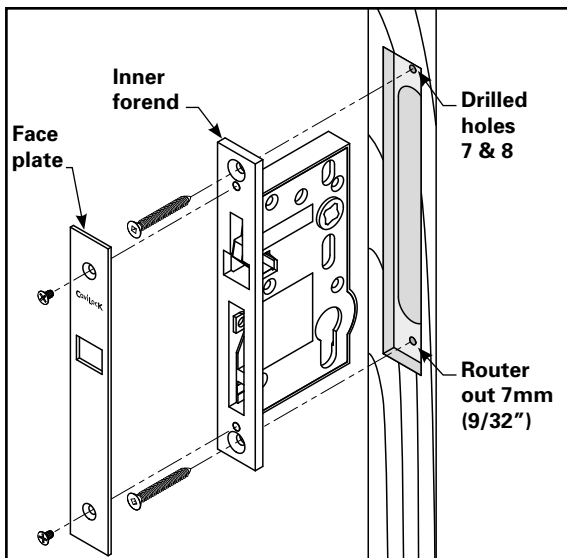

### Stage 4 - Fit Lock, Furniture and Cylinder

4  
STAGE

Fit lock into mortise and screw in place using #10 countersunk screws supplied.

Follow instructions relating to door furniture being installed.

#### A: CL100 LAVILOCK

1. Locking pin should be 0.5mm (1/64") shorter than door thickness. Cut to suit if required and de-burr the end.
2. Cut Lever & Rose handle screws to 19mm (3/4") larger than door thickness.
3. Refit faceplate.
4. Fit locking buttons with springs.
5. Check handing and hold indicator plates in place while fitting spindle and handles. Tighten screws enough to hold handles in place.
6. Test lock for the following:
  - A - Handles move freely.
  - B - Latch returns to the latched position when handle is let go.
  - C - Locking buttons move freely without jamming.
7. Line the face plates up to be parallel to the door edge.
8. Fully tighten handles to door.

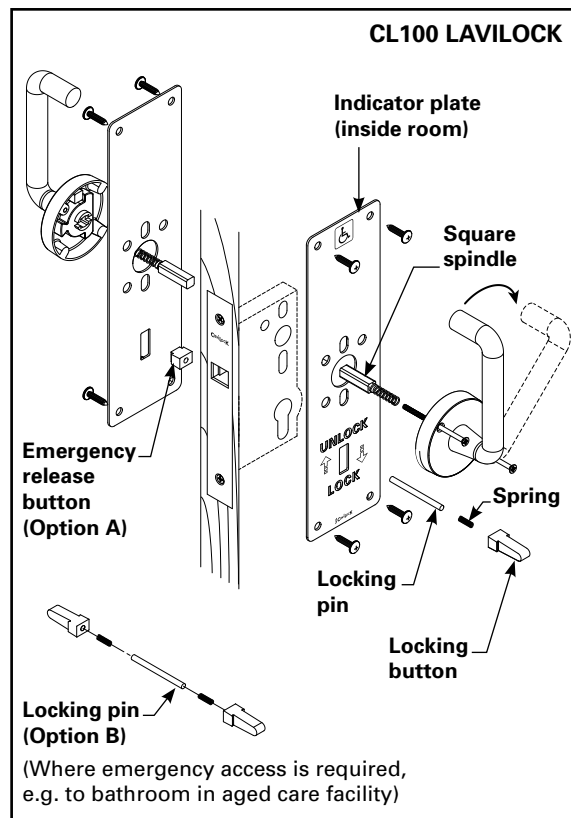

9. Drill holes for indicator plates and screw to door.

#### LAVILOCK Indicator Plate Holes

Hole Diameter	Depth	Door Side		
2.5mm	3/32"	25mm	1"	Both

## B: CL100 LEVER

1. Cut Lever & Rose handle screws to 19mm (3/4") larger than door thickness.
2. Fit handles with spindle loosely to door.
3. Fit Euro Cylinder (if required).  
Line up holes between cylinder and lock case.  
Screw together with cap screw.
4. Refit faceplate.
5. Test lock for the following:
  - A - Handles move freely.
  - B - Latch returns to latched position.
  - C - Key turns freely without jamming when locking and unlocking
6. Fully tighten handles to door.
7. Fit escutcheons around cylinder.

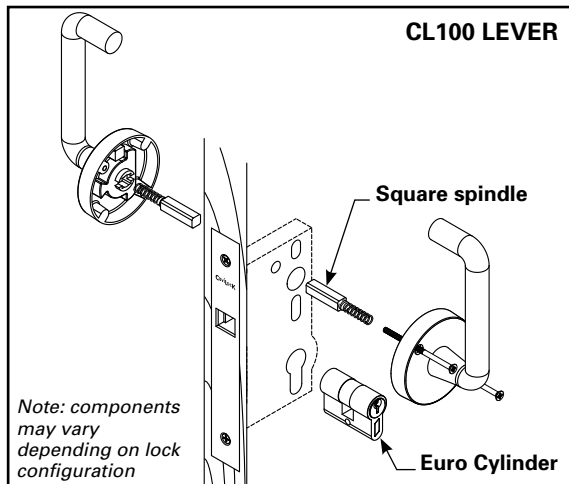

## C: CL100 FLUSH TURN

1. Cut spindle 5mm (13/64") shorter than door thickness.
2. Fit Flush Turn handles with spindle loosely to door.
3. Fit Euro Cylinder (if required).  
Line up holes between cylinder and lock case.  
Screw together with cap screw.
4. Refit the faceplate.
5. Test lock for the following:
  - A - Flush turns move freely.
  - B - Latch returns to the latched position.
  - C - Key turns freely without jamming when locking and unlocking
5. Fully tighten handles to door.
6. Fit escutcheons around cylinder.

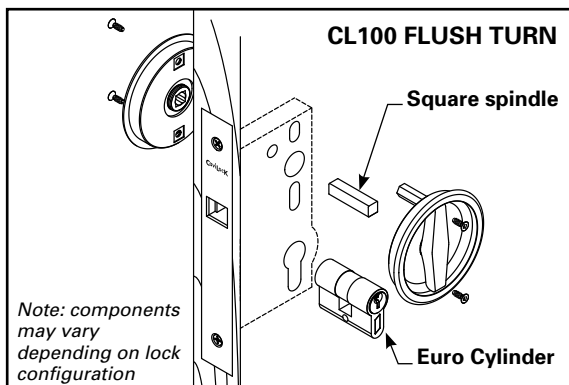

## D: CL100 DIGILOCK

1. Fit DigiLock loosely to door.
2. Fit Euro Cylinder (if required).  
Line up holes between cylinder and lock case.  
Screw together with cap screw.
3. Refit faceplate.
4. Format unlocking code.
5. Test lock for the following:
  - A - Handle turns freely when opening
  - B - Latch returns to the latched position.
  - C - Locking buttons move freely without jamming.
7. Fully tighten DigiLock to door.

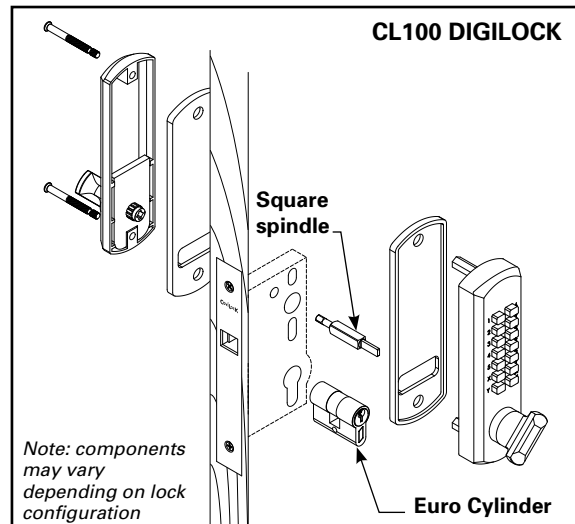

## Stage 5 - Fit Striker

1. Slide door closed and transfer height line from door onto closing jamb.
2. Cut out template where marked and align top of template with height line.
3. Ensure striker is facing right way up with slotted screw hole to top.
4. Mark top screw hole, ensuring it is in centre of closing jamb (use centre line marked on template).
5. Fit striker using top screw only.  
Close door slowly to check that striker lines up with lock.  
Adjust if necessary then fit bottom screw.  
On timber jambs you may mortise the back of the striker into the closing jamb to a depth of 3mm (1/8").

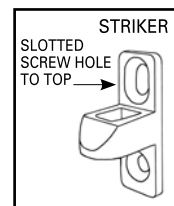

**5**  
STAGE

### IMPORTANT: THE CL100 IS NOT A DOOR STOP.

The door should be stopped in the correct closed position by the door stop, NOT the lock. If the door's momentum is not stopped by a closing jamb or an independent stop, long term damage may be done to the lock. To avoid this, ensure the door hits the jamb or stop at the same time that the striker bottoms out on the faceplate of the lock.

